

Guillaume Habert, Arno Schlueter (eds.)



# EXPANDING BOUNDARIES

## Systems Thinking in the Built Environment

Sustainable Built Environment (SBE) Regional Conference Zurich 2016





Guillaume Habert, Arno Schlueter (eds.)

# **EXPANDING BOUNDARIES**

## **Systems Thinking in the Built Environment**

Sustainable Built Environment (SBE) Regional Conference Zurich 2016



vdf Hochschulverlag AG an der ETH Zürich

Guillaume Habert, Arno Schlueter (eds.)

**Expanding Boundaries: Systems Thinking in the Built Environment**  
Sustainable Built Environment (SBE) Regional Conference Zurich 2016

Layout and Text Editing: Uta Gelbke  
Cover Design: Lukas Kunz, Uta Gelbke  
Event Photography: Giulia Celentano, Sasha Cisar

Images front cover (from left to right):  
Facades of the 'mehr als wohnen' project, © Ursula Meisser.  
Exterior view of the NEST building shell, © Roman Keller.  
The Adaptive Solar Facade mounted onto the House of Natural Resources,  
© ETH Zurich, Chair of Architecture and Building Systems.

Images back cover:  
SBE16 Zurich conference participants, all images © ETH Zurich, Chair of  
Sustainable Construction.

**Information on citation**

For citing individual papers please consider the following example:  
J. A. Fonseca and A. Schlueter, "Assessing the Performance and Resilience  
of Future Energy Systems at Neighborhood Scale" in: *Expanding Boundaries:  
Systems Thinking in the Built Environment*, edited by G. Habert and A.  
Schlueter, Zurich: vdf Hochschulverlag, 2016, pp. 96-101. Online under:  
<http://vdf.ch/expanding-boundaries.html> [date of access].

Instead of the URL you may also use the individual DOIs that have been  
assigned to each paper. They can be found in the footer of the respective  
title page.

**Bibliographic Information published by Die Deutsche Nationalbibliothek**

Die Deutsche Nationalbibliothek lists this publication in the Internet at  
<http://dnb.d-nb.de>.

This work is licensed under creative commons license  
CC BY-NC-ND 2.5 CH.



© 2016, vdf Hochschulverlag AG an der ETH Zürich

Download open access:  
ISBN: 978-3-7281-3774-6  
DOI: 10.3218/3774-6

[www.vdf.ethz.ch](http://www.vdf.ethz.ch)  
[verlag@vdf.ethz.ch](mailto:verlag@vdf.ethz.ch)

## Preface

Consuming over 40% of total primary energy, the built environment is in the centre of worldwide strategies and measures towards a more sustainable future. To provide resilient solutions, a simple optimisation of individual technologies will not be sufficient. In contrast, whole system thinking reveals and exploits connections between parts. Each system interacts with others on different scales (materials, components, buildings, cities) and domains (ecology, economy and social). Whole-system designers optimize the performance of such systems by understanding interconnections and identifying synergies. The more complete the design integration, the better the result.

System thinking theory is referring back to the early work of Donella and Dennis Meadows at MIT in the group created by Jay Forrester on System Dynamic. These theories have then been applied with success in many contexts. The application to the built environment is relatively new but is promising as buildings become more and more complex as well as interconnected.

System thinking is inherently linked to system boundaries. Spatial boundaries raise question such as where does the building stop and where does the neighbourhood start? Should we consider buildings as singular objects or as part of an infrastructure? Is it more effective to improve single buildings or entire districts? Temporal boundaries considerations can promote the use of dynamic assessment methods, which at each moment consider the real production and consumption of a system in order to calculate the environmental impact of energy positive neighbourhoods. Finally, expanding system boundaries also involves considering more than one single aspect of sustainability. Recent work focuses on a better description of the positive economic impact that new approaches and technology might have. Embracing the complexity of a socio-technical system such as the built environment is then difficult but seems to be required in order to propose grounded solutions for designers, planners and policy-makers.

In this book, the reader will find the proceedings of the 2016 Sustainable Built Environment (SBE) Regional Conference in Zurich. Papers have been written by academics and practitioners from all continents to bring forth the latest understanding on systems thinking in the built environment.

The editors would like to thank all participants for the inspiring conversations and extensive exchange of experience during the conference. We thank the authors of the papers for their efforts to provide outstanding and rigorous contributions. Finally, the editors are grateful to the various organisations and companies as well as the organising team for making this conference and these proceedings a success.

With kind regards,

Guillaume Habert, Arno Schlueter

## Organising Committee

ETH Zurich, Department of Civil, Environmental and Geomatic  
Engineering  
Chair of Sustainable Construction  
Guillaume Habert, Annette Walzer  
[www.sc.ibi.ethz.ch](http://www.sc.ibi.ethz.ch)

ETH Zurich, Department of Architecture  
Chair of Architecture & Building Systems  
Arno Schlueter, Uta Gelbke  
[www.systems.arch.ethz.ch](http://www.systems.arch.ethz.ch)

City of Zürich, Building Department  
Sustainable Building Section  
Annette Aumann  
[www.stadt-zuerich.ch/ahb](http://www.stadt-zuerich.ch/ahb)

Swiss Federal Office of Energy (SFOE)  
Head of Research for Buildings  
Andreas Eckmanns  
[www.bfe.admin.ch/forschunggebäude](http://www.bfe.admin.ch/forschunggebäude)



**DARCH**

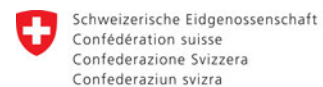

**Bundesamt für Energie BFE**  
**Swiss Federal Office of Energy SFOE**

# Sponsors & Support

The conference was sponsored by

**SIEMENS**

Media Partner



The conference was supported by



Isolda Agustì Juan – ETH Zurich  
Karen Allacker – KU Leuven  
Ben Mourad Amor – Université de Sherbrooke  
Coralie Brumaud – ETH Zurich  
Steve Burroughs – University of Canberra  
Paula Cadima – AA School, London  
Yudiesky Cancio Díaz – ETH Zurich  
Giulia Celentano – ETH Zurich  
Jacques Chevalier – CSTB  
Sasha Cisar – ETH Zurich  
Martin Cyr – INSA Toulouse  
Nele De Belie – Gent University  
Jorge De Brito – Instituto Superior Técnico, Lisboa  
Frank De Troyer – KU Leuven  
Sebastian Eberl – TU München  
Francesco Frontini – SUPSI, Manno  
Helena Gervasio – University of Coimbra  
Ravindra Gettu – IIT Madras  
Verena Göswein – ETH Zurich  
Niko Heeren – ETH Zurich  
Stefanie Hellweg – ETH Zurich  
Roland Hischier – EMPA Dübendorf  
Johannes Hofer – ETH Zurich  
Aoife Houlihan Wiberg – Norwegian University of Science and Technology  
Giuliana Iannaccone – Politecnico di Milano  
Dimitra Ioannidou – ETH Zurich  
Vanderley John – Universidade de São Paulo  
Viola John – ETH Zurich  
Jérôme Kämpf – EPF Lausanne  
Amnon Katz – Technion, Israel Institute of Technology  
Niklaus Kohler – Karlsruhe Institute of Technology  
Gnanli Landrou – ETH Zurich  
Sébastien Lasvaux – HES-SO  
Thomas Mach – TU Graz  
Snezana Marinkovic – University of Belgrade  
Fernando Martirena – Universidad Central Martha Abreu  
Urs-Peter Menti – Hochschule Luzern  
Alice Moncaster – University of Cambridge  
Zoltan Nagy – ETH Zurich  
Takafumi Noguchi – University of Tokyo  
Kristina Orehounig – EMPA Dübendorf  
Emeka Efe Osaji

Claudiane Ouellet-Plamondon – École de technologie supérieure, Montréal  
Pierryves Padey – HES-SO  
Jessen Page – HES-SO  
Sivakumar Palaniappan – IIT Madras  
Alexander Passer – TU Graz  
Bruno Peuportier – Mines Paris Tech  
Christoph Reinhart – MIT  
Nicolas Roussel – IFSTTAR, Marne-la-Vallée  
Ronald Rovers – ZUYD University, Heerlen  
Jean-Louis Scartezzini – EPF Lausanne  
José Silvestre – Universidade de Lisboa Portugal  
Flóra Szkordilisz – Hungarian Urban Knowledge Centre  
Arezki Tagnit-Hamou – Université de Sherbrooke  
Paola Tosolini – HEPIA Genève  
Franziska Trebut – Austrian Society for Environment and Technology, Vienna  
Ellen Van Bueren – TU Delft  
Johan Van Dessel – BBRI  
Anne Ventura – Nantes University  
Romeu Vicente – Campus Universitário de Santiago  
Holger Wallbaum – Chalmers University  
Michael Wetter – Lawrence Berkeley National Laboratory, Berkeley  
Stephen Wittkopf – Hochschule Luzern  
Bastian Wittstock – thinkstep AG, Leinfelden-Echterdingen  
Monika Woloszyn – Université Savoie Mont Blanc  
Simos Yannas – AA School, London  
Edwin Zea Escamilla – ETH Zurich  
Stefano Zerbi – HEPIA Genève  
Sharon Zingg – ETH Zurich  
Radu Zmeureanu – Concordia University, Montreal  
Daia Zwicky – Hochschule für Technik und Architektur Freiburg



Jan Carmeliet – ETH Zurich / EMPA Dübendorf  
Rolf Frischknecht – Treeze GmbH, Uster  
Heinrich Gugerli – Gugerli Dolder Umwelt & Nachhaltigkeit GmbH, Bülach  
Daniel Kellenberger – Intep, Zurich  
Susanne Kytzia – University of Applied Sciences Rapperswil  
Annick Lalive d’Epinay – Amt für Hochbauten, Stadt Zürich  
Joe Luthiger – Swiss Network for Sustainable Construction (NNBS), Zurich  
Olivier Meile – Swiss Federal Office for Energy (SFOE)  
Peter Richner – EMPA Dübendorf  
Urs Rieder – Hochschule Luzern  
Christian Schaffner – ETH Zurich  
Andreas Schüler – EPF Lausanne  
Michael Stauffacher – ETH Zurich  
Paola Tosolini – HEPIA Genève

# EXPANDING BOUNDARIES

## Systems Thinking in the Built Environment

Sustainable Built Environment (SBE)  
Regional Conference Zurich 2016

<b>01 Topic &amp; Program</b>	<b>1</b>
Introduction SBE16 Zurich Program SBE16 Zurich Poster and Session Schedule	
<b>02 Workshops</b>	<b>15</b>
City Energy Analyst Toolbox Management Game of a Building Material Supply Chain Sustainable Hybrid Building Sustainable Building Operation	
<b>03 Keynote Speakers</b>	<b>25</b>
Koen Steemers Peter Edwards Chrisna du Plessis Serge Salat Jens Feddern	
<b>04 Panel Discussion</b>	<b>37</b>
Smart Humans or Smart Meters?	
<b>05 Conference Papers</b>	<b>41</b>
Distributed Energy Systems and Infrastructure Life-Cycle Oriented Approaches Integrated Approaches and Tools for Decision-Making Innovative Materials and Components	
<b>06 Site Visits</b>	<b>733</b>
NEST at Empa Campus Tour – ETH Hoenggerberg Development of the District 'Hardau' Cooperative 'mehr als wohnen' Swiss Society of Engineers and Architects (SIA)	
<b>Appendix</b>	<b>745</b>
List of Authors	



# 01

## Topic & Program

<b>Introduction</b>	<b>2</b>
Systems Thinking in the Built Environment	
<b>SBE16 Zurich Program</b>	<b>4</b>
Conference week overview including all events	
<b>SBE16 Zurich Poster and Session Schedule</b>	<b>6</b>
Conference session schedule	

# EXPANDING BOUNDARIES

## Systems Thinking in the Built Environment

Sustainable Built Environment (SBE)  
Regional Conference Zurich 2016

### Introduction

Consuming over 40% of total primary energy, the built environment is in the focus of worldwide strategies and measures towards a more sustainable future. To provide resilient solutions, a simple optimisation of individual technologies will not be sufficient. In contrast, whole-system thinking reveals and exploits connections between otherwise disparate parts. Each system interacts with others on different scales (materials, buildings, cities) and domains (ecology, economy, social).

The need for such system thinking is reflected by the current shift in research from the perspective of single buildings to small urban neighborhoods and districts. The expansion of system boundaries opens up vast opportunities for interaction and synergies but also poses challenges due to an increase in complexity.

The SBE Regional Conference Zurich 2016 acted as a platform to discuss this shift between students, researchers and professionals and to foster system thinking in the built environment. The conference took place from June 13 to 17, 2016. SBE16 Zurich formed part of the international SBE series of conferences focusing on a sustainable built environment. It was accompanied by keynote speeches, workshops, and site visits to recent, cutting edge building projects in and around Zurich.

**On behalf of the hosts and organisers of this event – the city of Zurich, ETH Zurich, and the Swiss Federal Office of Energy – we would like to thank all participants for joining us in Zurich!**

**below:**

View of Zurich, © Zürich Tourismus.



A set of key conference topics were defined to prompt paper submissions that cover different aspects and scales of systems thinking. These key topics determined the content and structure of the main conference sessions.

#### **Distributed Energy Systems and Infrastructure**

Harnessing local, renewable energy sources is key to facilitate the transition towards low carbon energy systems. Rather than centralized and hierarchical, renewable energy generation will be increasingly decentralized, distributed and stochastic, which implies different strategies for design and operation. This calls for multi-scale modelling, simulation and analysis of different spatial and temporal resolutions, including the assessment of uncertainty and robustness. Understanding occupants and inhabitant's behaviour and comfort requirements leads to improved design and control of energy supply systems. Spatial distribution, local production and storage also demands considering urban morphology, infrastructure networks and potential links to transportation systems.

#### **Life-Cycle Oriented Approaches**

The consideration of all phases of the so-called life cycle of a building or a material is required when promoting new solutions for the built environment. Actually, the necessary quantification of the energy and materials needed for the production of products is not sufficient and a life cycle approach, integrating the energy and materials required during their use and demolition has to be considered. System boundaries of the studied objects are expanded from the cradle to the grave of objects, or even cradle to cradle when waste from one system can be used as new resources for a regenerated new one.

#### **Integrated Approaches and Tools for Decision-Making**

Systems thinking and integration is key to identify interdependencies and harness synergies between energy systems, material flows, urban form, program, transport and infrastructure. This requires new approaches, methods and tools to design, model and analyse such systems on different scales, from building to urban scale. Resulting tools need to address different stakeholders in design, planning, industry and public bodies.

#### **Innovative Materials and Components**

The new approach developed through systems thinking induces a new perception of resources available for construction and operation of our built environment. For instance, the appropriate use of low processed resources allows to develop low environmental impact building materials. But this approach also leads to new material and component needs such as components able to be reused and easily dismantled or new sensors for multi-scale and multi-criteria modelling such as radiant heat measurement.

## SBE16 Zurich Program

Seeking to involve different interested parties, the SBE16 Regional Conference in Zurich offered a varied yet well-coordinated conference program. It addressed students and academic scholars as much as planners, industry leaders and public representatives. The program combined lectures, discussions and tutorials with site visits and informal gatherings.

### Workshops

SBE16 Zurich offered half-day, 1-day and 2-day workshops which – each in their own way – grasped the topic of the conference. These workshops took place on June 13-14 and thus represented a practice-oriented beginning of the conference. They aimed to provide an opportunity for students, researchers and professionals for focused debates as well as hands-on experiences and explorations of new methods or technologies. The workshop results were presented following the opening program on Wednesday.

### Keynote Speakers

The SBE16 Zurich organising committee invited five renowned scholars and industry leaders to contribute to the conference through keynote lectures and to discuss the topic of sustainability in the context of built environments. Keynote speakers were Koen Steemers, Peter Edwards, Chrisna du Plessis, Serge Salat and Jens Feddern. Their lectures represented the theoretical frame of the conference. They have been recorded and can be viewed online. The individual links to each recording can be found in chapter 03 – *Keynote Speakers*.

### Poster Presentations

Short Poster Presentations of 1min each allowed to introduce the poster contributions which were on display in the foyer throughout the week.

### Conference Sessions

Conference Sessions took place on June 15-17 and were divided into the four main conference topics as described above. Lectures of 15 minutes were followed by 5 minutes of Q/A. A detailed session schedule is provided on the following pages and papers of both poster presentations and conference sessions have been listed in chapter 05 – *Conference Papers*.

### Panel Discussion

On Friday morning, following the keynote lecture, participants gathered in the main lecture hall for a panel discussion with invited experts from science, industry, planning and public administration. Under the title <Smart humans or smart meters? – The role of human and technology for a future sustainable built environment> each speaker brought his/her individual background to the table.

### Site Visits

A range of recent, cutting edge building projects in and around Zurich was selected to accompany the theoretical debate of the conference with practical examples. Conference participants had the choice between five site visits conducted by the respective project leaders or otherwise involved personnel. These visits took place on Thursday and Friday afternoon.

### Social Events

In addition to the formal program, the organising committee invited all participants to join the social gatherings on Tuesday and Thursday. The main conference part was kicked off with a Welcome Apéro in the ETH Dozentenfoyer overlooking the city of Zurich while the Conference Dinner at the g27 restaurant was a great opportunity to further discuss the outcome of the conference in a more informal setting.

**below:**

Overview of the SBE16 Zurich conference schedule, June 13 – 17, 2016.

Mon, June 13	Tue, June 14	Wed, June 15	Thu, June 16	Fri, June 17	
Workshops	Workshops	Opening Program	Keynote Chrisna du Plessis	Keynote Jens Feddern	
		Keynote Koen Steemers	Keynote Serge Salat	Panel Discussion	
		Poster Presentation / Coffee Break			
		Keynote Peter Edwards	Conference Sessions	Conference Sessions	
		Presentation Workshops			
		Lunch Break			
		Conference Sessions	Conference Sessions	Conference Sessions	
		Coffee Break	Site Visits	Closing Program	
		Conference Sessions		Farewell Coffee	Site Visit
			Welcome Apéro		Conference Dinner



## SBE16 Zurich Poster and Session Schedule

### Poster Presentations

Posters were displayed in the conference foyer for the entire duration of the conference. We invited all poster authors to give a short presentation of 1 minute according to the schedule below. For the purpose of this book, poster presenters were asked to provide full papers. These have been allocated to the four conference topics and are included in chapter 05 – *Conference Papers*.

### Poster Session 1

June 15 / 10:30–10:45

Annette Hafner – Ruhr-University Bochum  
 Paolo Civiero – Sapienza University of Rome  
 Karina Krause – Ruhr-University Bochum  
 Nazanin Eisazadeh – KU Leuven  
 Alexandra Saur – Lucerne University of Applied Sciences and Arts  
 Lavinia Chiara Tagliabue – Politecnico di Milano  
 Daia Zwicky – HEIA Fribourg  
 Aoife Anne-marie Houlihan Wiberg – The Research Centre on Zero  
 Emission Buildings, Trondheim  
 Sergi Aguacil – EPF Lausanne  
 Mehmet Aksözen – ETH Zurich

### Poster Session 2

June 16 / 10:30–10:45

Lisa Wastiels – Belgian Building Research Institute  
 Catherine De Wolf – Massachusetts Institute of Technology  
 Herbert Claus Leindecker – University of Applied Sciences Upper Austria  
 Christian Steininger – Vasko + Partner Ingenieure, Vienna  
 Ferdinand Oswald – Graz University of Technology  
 Junjing Yang – National University of Singapore  
 Azza Kamal – The University of Texas at San Antonio  
 Eric Teitelbaum – Princeton University  
 Florian Gschösser – University of Innsbruck  
 Viola John – ETH Zurich  
 Cappai Francesco – École de technologie supérieure, Montreal

### Conference Sessions

Conference Sessions were divided into four main topics and additional subtopics as defined below. Presenters gave a 15 minute presentation, followed by 5 minutes of discussion. All papers have been listed in chapter 05 – *Conference Papers*.

**1**

#### **Distributed Energy Systems and Infrastructure**

- 1.1 Urban scale energy systems (and tools)
- 1.2 Smart living labs and campuses
- 1.3 Building performance and human interaction

**2**

#### **Life-Cycle Oriented Approaches**

- 2.1 Building stock (life-cycle) analysis
- 2.2 Building and infrastructure renovation and retrofitting
- 2.3 Life-cycle assessment of materials and processes

**3**

#### **Integrated Approaches and Tools for Decision-Making**

- 3.1 Engaging stakeholders and local communities
- 3.2 Indices and scoring systems
- 3.3 Design support

**4**

#### **Innovative Materials and Components**

**1.1****Urban scale energy systems (and tools)**

Chair: Andreas Eckmans – BFE

**Stephan Maier** – Graz University of Technology

“Optimal Energy Technology Networks in Spatial Energy Planning in Austrian City Quarters”

**Anja Willmann** – ETH Zurich

“Energy and the City: Investigating Spatial and Architectural Consequences of a Shift in Energy Systems on District Level in a Summer School”

**Raphael Wu** – ETH Zurich

“Optimal Energy System Transformation of a Neighbourhood”

**Thomas Schluck** – Lucerne University of Applied Sciences and Arts

“Matching Renewable Energy Production and Consumption by Market Regulated Demand Site Management (DSM)”

**Christoph Waibel** – Empa

“Holistic Optimization of Urban Morphology and District Energy Systems”

**2.2****Building and infrastructure renovation and retrofitting**

Chair: Mehmet Aksözen – ETH Zurich

**Eero Nippala** – Tampere University of Applied Sciences

“Deep Renovations within Smart Asset Management”

**Karen Allacker** – KU Leuven

“A Multi-Criteria Approach for the Assessment of Housing Renovation Strategies”

**Angela Greco** – TU Delft

“Business Case Study for the Zero Energy Refurbishment of Commercial Buildings”

**Alexander Passer** – Graz University of Technology

“Impact of Building Refurbishment Strategies on the Energetic Payback”

**Sébastien Lasvaux** – University of Applied Sciences of Western Switzerland

“Economic and Environmental Assessment of Building Renovation: Application to Residential Buildings Heated with Electricity in Switzerland”

**3.1****Engaging stakeholders and local communities**

Chair: Guillaume Habert – ETH Zurich

**Aoife Brophy Haney** – ETH Zurich

“What a MES(S)!: A Bibliometric Analysis of the Evolution of Research on Multi-Energy Systems”

**Giulia Barbano** – iiSBE Italia

“Engaging Stakeholders through Local Project Committees”

**Helmuth Kreiner** – Graz University of Technology

“Management of User and Stakeholder Interests in Multi-Criteria Assessments”

**Emanuele Facchinetti** – Lucerne University of Applied Sciences and Arts

“Business Model Innovation for Local Energy Management: A Systematic Methodology”

**Sébastien Cajot** – EIFER and **Nils Schüler** – EPFL

“Establishing Links for the Planning of Sustainable Districts”

**1.1****Urban scale energy systems (and tools)**

Chair: Forest Meggers – Princeton University

**David Grosspietsch** – ETH Zurich

“Matching Renewable Energy Production and Local Consumption: A Review of Decentralized Energy Systems”

**Surabhi Mehrotra** – IIT Bombay

“Built from Determinants of Urban Land Surface Temperature: A Case of Mumbai”

**Jérôme Kämpf** – EPFL

“Integration of Outdoor Human Comfort in a Building Energy Simulation Database Using CityGML Energy ADE”

**Jérôme Kämpf** – EPFL

“Multi-Scale Modelling to Assess Human Comfort in Urban Canyons”

**Jimeno Fonseca** – ETH Zurich

“Assessing the Performance and Resilience of Future Energy Systems at Neighborhood Scale”

**2.3****Life-cycle assessment of materials and processes**

Chair: Karen Allacker – KU Leuven

**Florian Gschösser** – University of Innsbruck

“Environmental Effects of an Alpine Summit Tunnel”

**José Silvestre** – University of Lisbon

“Selection of Environmental Datasets as Generic Data: Application to Insulation Materials within a National Context”

**Laetitia Delem** – BBRI

“€coffice-LCC and LCA as Part of the Integrated Design Approach for a High Performance-Low Cost Office Building”

**Meta Lehmann** – econcept AG

“Sustainable Stepwise Building Renovation”

**Viola John** – ETH Zurich

“Environment and Economy - An Alliance of Mutual Benefits in Residential Building”

**3.3****Design support**

Chair: Daniel Kellenberger – Intep

**Claudiane Ouellet-Plamondon** – ETS

“Ecological Footprint Analysis of Canadian Household Consumption by Building Type and Mode of Occupation”

**Charlotte Roux** – Mines ParisTech

“Life Cycle Assessment as a Design Aid Tool for Urban Projects”

**Ayu Miyamoto** – KU Leuven

“From a Simple Tool for Energy Efficient Design in the Early Design Phase to Dynamic Simulations in a Later Design Stage”

**Elke Meex** – Hasselt University

“Analysis of the Material-Related Design Decision Process in Flemish Architectural Practice”

**Dimitra Ioannidou** – ETH Zurich

“Economic Flow Analysis of Construction Projects to Support Sustainable Decision-Making”

**1.1****Urban scale energy systems (and tools)**

Chair: Jérôme Kämpf – EPFL

**Flora Szkordilis** – Hungarian Urban Knowledge Centre

“Facilitating Climate Adaptive Urban Design – Developing a System of Planning Criteria in Hungary”

**Paul Michael Falk** – Darmstadt University of Technology

“Comparison of District Heating Systems and Distributed Geothermal Network for Optimal Exergetic Performance”

**Eric Teitelbaum** and **Forrest Meggers** – Princeton University

“Campus as a Lab: Building- and System-Level Air Movement Investigations”

**Georgios Mavromatidis** – ETH Zurich

“Uncertainty and Sensitivity Analysis for the Optimal Design of Distributed Urban Energy Systems”

**Dan Assouline** – EPFL

“Does Roof Shape Matter? Solar PV Integration on Roofs”

**2.3****Life-cycle assessment of materials and processes**

Chair: Peter Richner – Empa

**Ardavan Yazdanbakhsh** – City College of New York

“A Framework for Life Cycle Assessment of Concretes with Recycled Aggregates in Large Metropolitan Areas”

**Snezana Marinkovic** – University of Belgrade

“Life Cycle Analysis of Recycled Aggregate Concrete with Fly Ash as Partial Cement Replacement”

**Jiangbo Wu** – Chongqing University

“Eco-Efficiency of Construction and Demolition Waste Recycling in Chongqing, China”

**Amnon Katz** – Technion-Israel Institute of Technology

“Efficiency of Using Recycled Fine Aggregate for a New Concrete”

**Philip Van den Heede** – Ghent University

“The Cost and Environmental Impact of Service Life Extending Self-Healing Engineered Materials for Sustainable Steel Reinforced Concrete”

**3.3****Design support**

Chair: Annick Lalive d’Epinay – City of Zurich

**Emilie Nault** – EPFL

“Urban Planning and Solar Potential: Assessing Users’ Interaction with a Novel Decision-Support Workflow for Early-Stage Design”

**Carsten K. Druhm** – ZHAW

“Increase the Efficiency in Sustainable Construction Using BIM”

**Daren Thomas** – ETH Zurich

“The City Energy Analyst Toolbox V0.1”

**Alexander Hollberg** – Bauhaus-University Weimar

“A Method for Evaluating the Environmental Life Cycle Potential of Building Geometry”

**Angela Greco** – TU Delft

“Economic Factors for Successful Net Zero Energy Refurbishment of Dutch Terraced Houses”

## 1.2

**Smart living labs and campuses**

Chair: Christian Schaffner – ETH Zurich

**Arianna Brambilla** – EPFL

“LCA as Key Factor for Implementation of Inertia in a Low Carbon Performance Driven Design: The Case of the Smart Living Building in Fribourg, Switzerland”

**Lavinia Chiara Tagliabue** – Politecnico di Milano

“Tuning Energy Performance Simulation on Behavioural Variability with Inverse Modelling: The Case of Smart Campus Building”

**Sameer Abu-Eisheh** – An-Najah National University

“Strategic Planning for the Transformation of a University Campus Towards Smart, Eco and Green Sustainable Built Environment: A Case Study from Palestine”

**Endrit Hoxha** – EPFL

“Introduction of a Dynamic Interpretation of Building LCA Results: The Case of the Smart Living Building in Fribourg, Switzerland”

**Peter Richner** – Empa

“NEST – Exploring the Future of Buildings”

## 2.3

**Life-cycle assessment of materials and processes**

Chair: Amnon Katz – Technion University

**Alessandro P. Fantilli** – Politecnico di Torino

“Eco-Mechanical Performances of UHP-FRCC: Material vs. Structural Scale Analysis”

**Sofia Sanchez** – Universidad Central de las Villas

“Low Carbon Cement: A Sustainable Way to Meet Growing Demand in Cuba”

**Lara Jaillon** – City University of Hong Kong

“Life Cycle Assessment of Precast and Cast-In-Situ Construction”

**Ravindra Gettu** – IIT Madras

“Process Mapping and Preliminary Assessment of Life Cycle Impact in Indian Cement Plants”

**Alessandro Arrigoni** – Politecnico di Milano

“The Environmental Relevance of the Construction and End-Of-Life Phases of a Building: A Temporary Structure LCA Case Study”

## 4

**Innovative materials and components**

Chair: Alexander Passer – TU Graz

**Daniel Friedrich** – Lucerne University of Applied Sciences and Arts

“Bio-Based Plastics-Composites for Sustainable Building Skins: Life Expectancy of Cladding Derived from Wind Suction Tests”

**Marvin King** – Lucerne University of Applied Sciences and Arts

“Holistic Observations on the Sustainability of High-Rise Building Facades”

**Giuliana Iannaccone** – Politecnico di Milano

“Integrated Approaches for Large Scale Energy Retrofitting of Existing Residential Building through Innovative External Insulation Prefabricated Panels”

**Aurelie Favier** – EPFL

“Limestone Calcined Clay Cement for a Sustainable Development”

**Matthias Pätzold** – Technical University of Munich

“Design-Engineering-Based and Material-Based Improvement of Precast Concrete-Facade-Elements”

## 1.3

**Building performance and human interaction**

Chair: Zoltan Nagy – ETH Zurich

**Zoltan Nagy** – ETH Zurich

“What Should a Building be Controlled for? Ask the Occupants!”

**Lavinia Chiara Tagliabue** – Politecnico di Milano

“Prediction of Users’ Behaviour Patterns Impact on Energy Performance of a Social Housing in Cremona, Italy”

**Olivia Guerra-Santin** – TU Delft

“Towards Sustainable Occupant Behavior and Organizational Change”

**Nadine Haufe** – Vienna University of Technology

“Modelling Load Profiles for the Residential Consumption of Electricity Based on a Milieu-Oriented Approach”

**Junjing Yang** – National University of Singapore

“A Methodology for Energy Audit for Commercial Buildings Using Machine Learning Tools”

## 2.1

**Building stock (life-cycle) analysis**

Chair: Suzanne Kytzia – HSR

**Adélaïde Mailhac** – CSTB

“LCA Enhancement Perspectives to Facilitate Scaling up from Building to Territory”

**Adélaïde Mailhac** – CSTB

“LCA Applicability at District Scale Demonstrated Throughout a Case Study: Shortcomings and Perspectives for Future Improvements”

**Fritz Kleemann** – Vienna University of Technology

“Combining GIS Data Sets and Material Intensities to Estimate Vienna’s Building Stock”

**Alessio Mastrucci** – Luxembourg Institute of Science and Technology

“A GIS-Based Approach for the Energy Analysis and Life Cycle Assessment of Urban Housing Stocks”

**Stefan Schneider** – University of Geneva

“Geo-Dependent Heat Demand Model of the Swiss Building Stock”

## 4

**Innovative materials and components**

Chair: Claudiane Ouellet-Plamondon – ETS

**Ken Zumstein** and **Laurent Cattarinussi** – ETH Zurich

“Life Cycle Assessment of a Post-Tensioned Timber Frame in Comparison to a Reinforced Concrete Frame for Tall Buildings”

**Gnanli Landrou** – ETH Zurich

“A New Route for Self-Compacting Clay Concrete”

**Alessandro Arrigoni** – Politecnico di Milano

“Improving Rammed Earth Walls’ Sustainability through Life Cycle Assessment (LCA)”

**Andrea Klinge, Eike Roswag-Klinge** – Ziegert | Roswag | Seiler

Architekten Ingenieure

“Naturally Ventilated Earth Timber Constructions”

**Sharon Zingg** – ETH Zurich

“Environmental Assessment of Radical Innovation in Concrete Structures”

**1.3****Building performance and human interaction**

Chair: Arno Schlueter – ETH Zurich

**António José de Figueiredo** – University of Aveiro

“Overheating Reduction of a Cold Formed Steel-Framed Building Using a Hybrid Evolutionary Algorithm to Optimize Different PCM Solutions”

**Hongshan Guo** – Princeton University

“Model Predictive Control for Geothermal Borehole Depth Determination”

**Coosje Hammink** – Hogeschool van Arnhem en Nijmegen

“Integrating Persuasive Technology in Prototypes of Interior Walls to Stimulate Behavioural Change”

**Ali Motamed** – EPFL

“Toward an Integrated Platform for Energy Efficient Lighting Control of Non-Residential Buildings”

**Luca Baldini** – Empa

“Dynamic Energy Weighting Factors to Promote the Integration of Renewables into Buildings”

**2.1****Building stock (life-cycle) analysis**

Chair: Sébastien Lasvaux – HES-SO

**Yudiesky Cancio Diaz** – Universidad Central de las Villas

“Economic and Ecological Assessment of Cuban Housing Solutions Using Alternative Cement”

**Ahmed Mokhtar** – American University of Sharjah

“A Sustainable Development Approach for Affordable Housing in Egypt”

**Isolda Agustí-Juan** – ETH Zurich

“Environmental Implications and Opportunities of Digital Fabrication”

**Vanessa Gomes** – University of Campinas

“A Novel Perspective on the Avoided Burden Approach Applied to Steel-Cement Making Joint System”

**Jovan Pantelic** – ETH Zurich

“Air Dehumidification with Novel Liquid Desiccant System”

**3.2****Indices and scoring systems**

Chair: José Silvestre – University of Lisbon

**Karen Allacker** – KU Leuven

“Which Additional Impact Categories Are Ready for Uptake in the CEN Standards EN 15804 and EN 15978? Evaluation Framework and Intermediate Results”

**Daniela Pasini** – Politecnico di Milano

“Integrated Process for the Evaluation and Optimization of Buildings Performance”

**Damien Trigaux** – KU Leuven

“Critical Analysis of Sustainability Scoring Tools for Neighbourhoods, Based on a Life Cycle Approach”

**Olivia Guerra-Santin** – TU Delft

“Building Occupancy Certification: Development on an Approach to Assess Building Occupancy”

**Manuela Prieler** – FH Salzburg

“Renovation in Austria – Analysis of the Energy Performance Certificates between the Years 2006 and 2015 of the County Salzburg”





# 02

## Workshops

<b>City Energy Analyst Toolbox</b>	<b>16</b>
A computational framework for the analysis of building energy systems at neighbourhood and district scales	
<b>Management Game of a Building Material Supply Chain</b>	<b>18</b>
A system dynamics management game displaying material and information flows	
<b>Sustainable Hybrid Building</b>	<b>20</b>
A multidisciplinary approach to mixed-use buildings in small urban districts	
<b>Sustainable Building Operation</b>	<b>22</b>
A discussion on roles and responsibilities in the field of sustainable building operation	



### City Energy Analyst Toolbox

June 13 & 14 / 9:00 – 18:00

**Description:** The City Energy Analyst (CEA) is a novel computational framework for the analysis of building energy systems at neighborhood and district scales developed at ETH Zurich. The framework, which is based on ArcGIS, helps define strategies for minimizing energy intensity, carbon footprint and annual costs of energy services in an urban context.

Participants were invited to take part in the first public CEA Toolbox workshop, as part of the SBE16 conference held at ETH Zurich. The 2-day session consisted of theoretical input, as well as individual and group work. The participants came from a wide range of backgrounds from design-based disciplines (e.g. architects and urban designers) to engineering (e.g. mechanical, civil and energy systems experts and consultants) and ranging in position from PhD student to assistant professor. The workshop had a total number of 9 participants from 7 different countries in 3 continents representing 8 institutions.

**Organisers:** Amr Elesawy, Anja Willmann, Martin Mosteiro (ETH Zurich, Chair of Architecture and Building Systems) and Jimeno Fonseca (Future Cities Laboratory, Singapore-ETH Centre)

**Review by Organisers:** The workshop intended to present the tool to a diverse audience and check its role in creating synergies between various scenarios in an urban context, with the aim of reducing energy consumption and GHG emissions. It also aimed to assess the user friendliness of the tool as well as its importance in the field. The first half of the workshop consisted of an introduction to ArcGIS as the underlying software and the concept of the CEA toolbox, a theoretical input on urban energy systems, the different demand types and how they are assessed, GHG emissions and the benchmarks used for evaluating the simulation outcomes.

Afterwards, the participants were assigned a number of individual tasks to conduct their first simulations using the tool, as well as investigating the results and presenting them through various visualization techniques. Following this step, the main project of the workshop was introduced, in which 274 buildings in the center campus area of the city of Zurich were to be analyzed. The participants were organized in 3 groups and were presented a number of future scenarios for the city quarter to explore the impact of occupancy, varying climates and retrofitting existing buildings and energy sources. However, they were given flexibility to add, modify or choose new themes to work with. All simulation results were compared to the Swiss 2000-watt-society targets.

The participants demonstrated both the capability to work with the tool independently as well as expanding the proposed scenarios with considerations of urban densification and energy mixes, thus going beyond the workshop's original expectations. Following the scenario development and simulations, each group presented their results, consisting of 4 to 10 scenarios per group and 4 to 8 full simulations per participant.

At the end, participants were asked for feedback on the workshop and the toolbox itself. While the theoretical content of the workshop was generally considered adequate, a large number of participants expressed interest in a longer workshop, in which a third day could be used to analyse the calculation methods in detail. Regarding the toolbox itself, a majority of the participants rated the tool's user friendliness and their likelihood to use the tool again with 7 or more, though some participants expressed that they would like to see the tool being further developed in order to expand its usefulness and importance.

**PROCESS**

**OUTPUT**

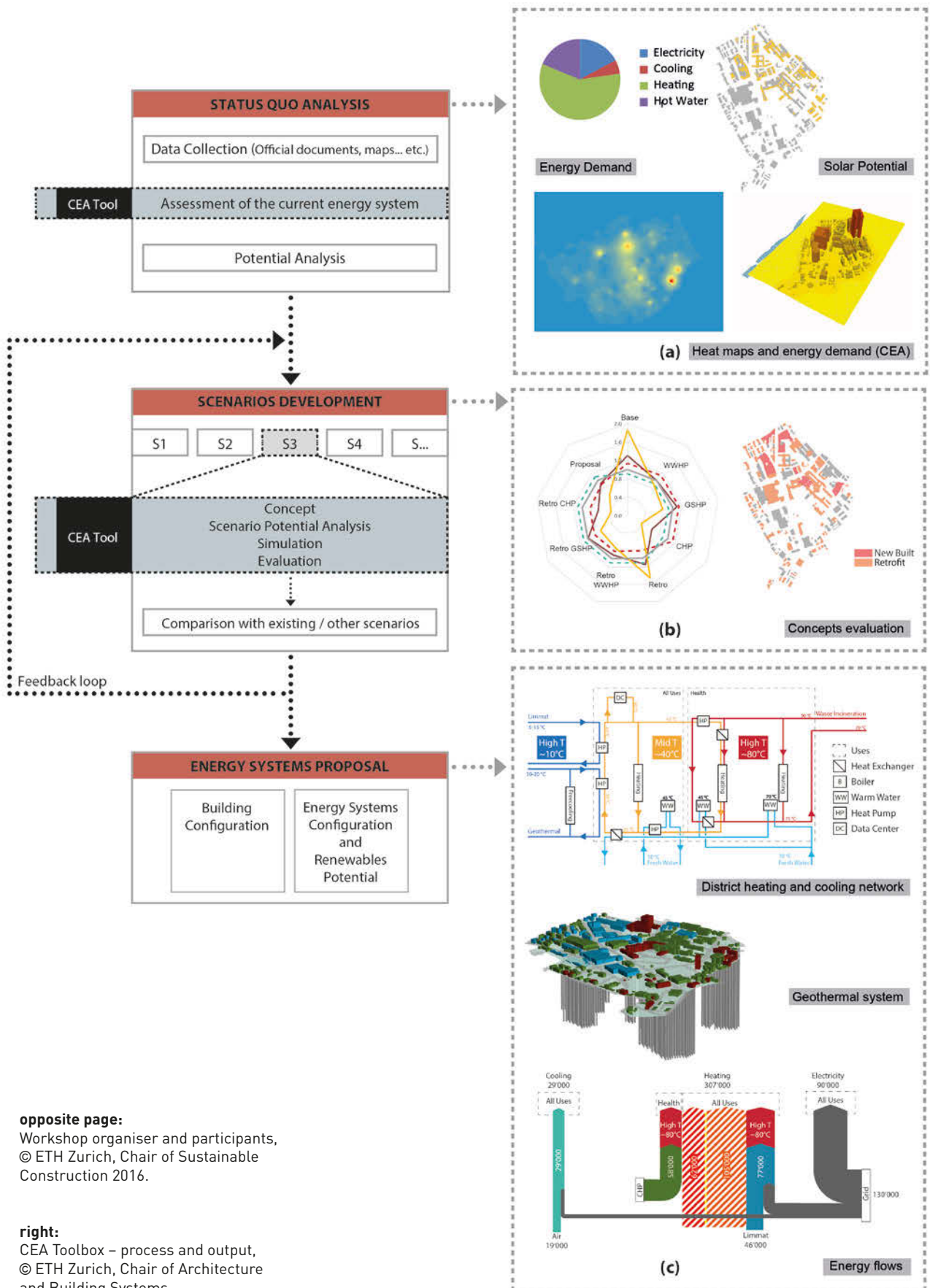

**opposite page:**  
 Workshop organiser and participants,  
 © ETH Zurich, Chair of Sustainable  
 Construction 2016.

**right:**  
 CEA Toolbox – process and output,  
 © ETH Zurich, Chair of Architecture  
 and Building Systems.

## Management Game of a Building Material Supply Chain

June 14 / 14:00 – 17:00

**Description:** Building material supply chains form part of the complexity of built environments. They involve multiple actors and a constant flow of material and information between them. This system dynamics management game involved a supply chain with four companies and the respective material and information flows. Participants took the role of a company and decided – based on their inventory situation and customer orders – how much to order from their suppliers. All companies had a common goal: Minimizing costs for capital in the supply chain by maintaining low stocks but managing to deliver all orders. The players experienced decision-making and coordination problems as well as the pressure that emerges from other actors and from 'the system'.

This exercise enhances general systems thinking capabilities. Players are introduced to important concepts of systems thinking and causal loop diagrams.

**Organiser:** Nici Zimmermann (Institute for Environmental Design and Engineering, University College London (UCL), The Bartlett)

**Review by Organiser:** The players experienced all the ups and downs of managing a complex supply chain. They were engaged and eager to keep their inventories within reasonable bounds, but they had to cope with backlogs of up to 100 items, caused by an increase in demand of only 4 items per week.

These difficulties are a typical outcome of this learning experience, of tool and even commodity supply chains. We used the concrete experience to discuss the structure of supply chains in general and how its information and material delays create ripple effects and the so-called 'bullwhip effect'. We also explored how we can change the underlying structure, e.g. by linking the retailer's information directly with the factory that is many kilometres and organisations apart. Then we discussed the ability of transferring insights from the very lean automotive supply chains to the housing construction context, limited e.g. through a different distribution of power across organisations and through the transient nature of project-based construction supply chains.

It was an exciting and successful workshop!

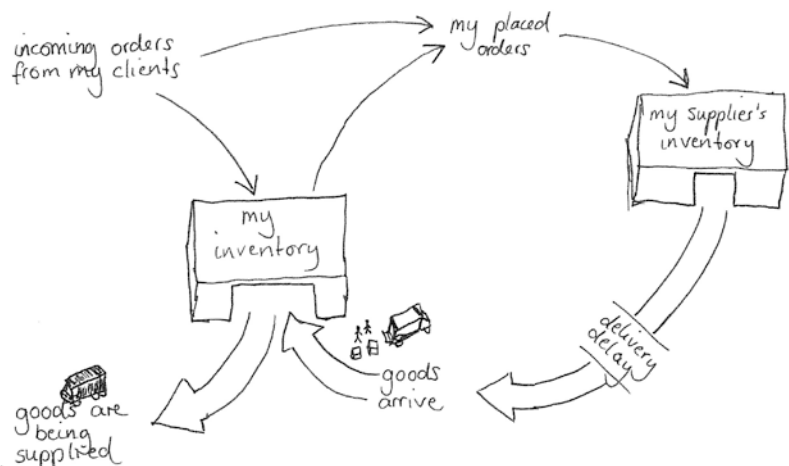



**opposite page:**  
System diagram.

**right:**  
Workshop in progress,  
© ETH Zurich, Chair of Sustainable  
Construction 2016.



## Sustainable Hybrid Building

June 13 / 9:00 – 19:00

**Description:** *A multidisciplinary approach to mixed-use buildings in small urban districts.* The demand for high density together with the demand of maintaining the diversity of services, retails, cultural facilities, and social mix raises the question whether mono-functional buildings are still adequate to provide resilient sustainable solutions for the city of tomorrow. A hybrid building combines several programs in one fabric. It could be managed by public-private partnerships and could be accessible 24/7. The workshop discussed the design of small to medium size hybrid buildings as one of the possible responses to the shortage of housing land, to reduce transport carbon dioxide and energy consumption in urban areas, to preserve resources and to reduce operating costs. Mixed-use, hybrid buildings foster integrated approaches to energy and resource efficiency.

**Organisers:** Paola Tosolini (HEPIA Geneva/ HES-SO University of Applied Arts and Sciences of Western Switzerland), Jessen Page (HEVS Valais-Wallis/ HES-SO), and Ricardo Lima (HEPIA/HES-SO)

### Review by Organisers:

The 1-day workshop was organized in two sessions, – one including theoretical input on hybrid building design, the other with group work on a case study in Grand-Sacconex - Geneva, in a sector near the airport. Participants identified and defined synergies among different buildings programs that can improve the sustainability of the building. Reduced energy consumption, preservation of natural resources, and social cohesion are some of the issues that have been discussed.

The workshop participants first identified the best strategic location for the hybrid building in the Susette Sector and then sketched it by defining a program based on a multidisciplinary approach. They considered local urban needs, evaluated the potential range/degrees of interaction among program spaces, defined the thermal zoning of the building, and finally explored and combined energy demand profiles of the diverse programs in order to optimise energy efficiency and renewable energy consumption.

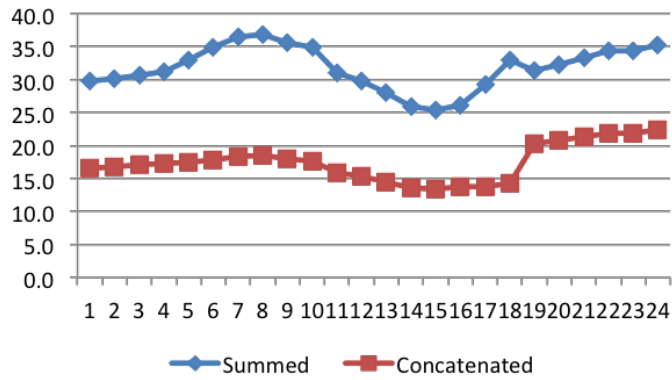
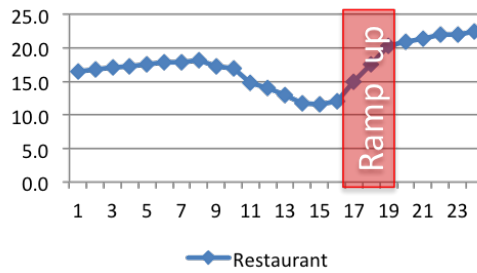
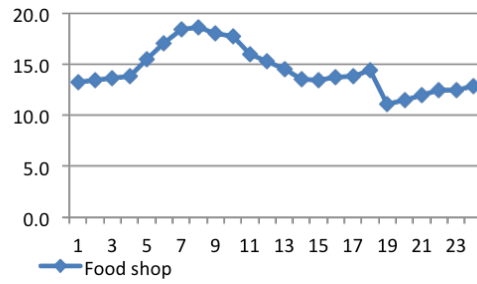

**above:**  
More efficient use of heating/cooling systems due to concatenated demand.

**opposite page and right:**  
Workshop organisers and participants,  
© ETH Zurich, Chair of Sustainable Construction 2016.





## Sustainable Building Operation

June 14 / 15:00 – 17:00

**Description:** What means “sustainable operation”? Several guidelines, norms, certification schemes etc. are available for sustainable construction, but few are dealing with sustainable operation. And those who address the issue have different structures (e.g. product or process orientated), approaches (e.g. performance or qualitative orientated) and viewpoints (planner, investor etc.). This leads to the following sub questions, which were to be discussed during the workshop in order to arrive at a common, further understanding of the topic:

- Which approach is useful for a description and assessment of sustainable building operation?
- What are the linking points of contact between sustainable planning and construction and sustainable operation?
- How should the different responsibilities and roles be distributed?

The workshop followed the *World Café* format – short impulse presentation by organisers, 3-4 tables for discussion (stakeholder views) with 1 moderator per table. For each sub question, the results obtained in the groups were summarized in a document, including a photo protocol which was presented at the conference.

**Organisers:** Carsten K. Druhmänn (ZHAW – Zürcher Hochschule für Angewandte Wissenschaften, head of «FM digital», Institute of Facility Management) and Stefan Jäschke (ZHAW, Institute of Facility Management, Energy Management)

**Review by Organisers:** The workshop started with a brief introduction of the participants; the most represented profession was architecture. So a short introduction to Facility Management and Building Operation was given by the organisers. It was followed by an introduction to sustainable building operation, information about the pre-project *Standard Sustainable Operation Switzerland*, including an insight into existing assessment systems. This led to a lively discussion around two central topics:

- How to involve users and tenants of buildings in sustainable operation or encourage them to support it instead of counteracting sustainability optimised buildings during operation (keywords: e.g. green lease contracts, performance gap).
- The certification of FM service providers was considered, important so that companies, like certificates for sustainable buildings (e.g. SNBS, DGNB), can provide proof of meeting their sustainability goals. Sustainable building operation would be best applicable if the triad of owners, users / tenants and service providers works.

**DAS DGNB ZERTIFIKAT  
FÜR GEBÄUDE IM BETRIEB  
(GIB, VERSION 1.1)**

**KRITERIEN FÜR DAS DGNB NUTZUNGSPROFIL  
„GEBÄUDE IM BETRIEB“ (GIB, VERSION 1.1)**

© DGNB GmbH

<b>GEFMA</b>		<b>Nachhaltigkeit im Facility Management Bewertungssystem</b>
		<b>Kriterienkatalog</b>
Themenfeld	Nr.	Kriterium
Ökologische Qualität	1.1	Energiemanagement
	1.2	Wassermanagement
	1.3	Erleuchtungsmanagement
	1.4	Wärmemanagement
Ökonomische Qualität	2.1	Nutzungskostenmanagement
Soziokulturell-funktionale Qualität	3.1	Nutzerzufriedenheitsmanagement
	3.2	Stör- und Beschwerdemanagement
	3.3	Rechtakformität
	3.4	Raumluft- und Trinkwasserqualität
	3.5	Gebäudesicherheitsmanagement
	3.6	Arbeitssicherheitsmanagement
Qualität der FM-Organisation	4.1	Betriebsstrategie
	4.2	Personal
	4.3	Ablauforganisation / Prozesse
	4.4	Dokumentation und Berichtswesen
	4.5	Beschaffung
Details der Services	5.1	Flächenmanagement
	5.2	Betreiben nach 32736
	5.3	Instandhaltung nach DIN 31051
	5.4	TUM Projekte (Modernisierung / Sanierung / Umbau)
	5.5	Reinigung
	5.6	Außenanlagen inkl. Winterdienst
	5.7	Catering
	5.8	Security

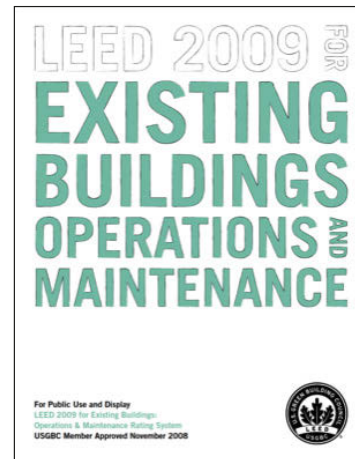
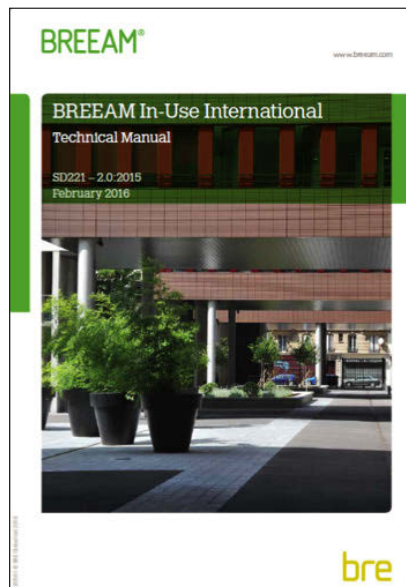

**right:**  
Building operation manuals  
and certificates.



# 03

## Keynote Speakers

<b>Koen Steemers</b> – University of Cambridge	<b>26</b>
‘Urban Form and Energy: Systems Thinking and Environmental Diversity’	
<b>Peter Edwards</b> – Singapore-ETH Centre	<b>28</b>
‘Future Cities Laboratory: Innovative Research for Sustainable Cities’	
<b>Chrisna du Plessis</b> – University of Pretoria	<b>30</b>
‘Thriving in the Symbiocene: A Message of Hope’	
<b>Serge Salat</b> – Urban Morphology and Complex Systems Institute Paris	<b>32</b>
‘Systems Thinking for Integrated Sustainable Urban Planning’	
<b>Jens Feddern</b> – Siemens Building Technologies	<b>34</b>
Expanding Boundaries: Systems Thinking for Building Performance’	



### Koen Steemers

University of Cambridge

Koen Steemers was recently named in *Building Design's* inaugural list of the "50 most influential people in UK sustainability". He studied Architecture at the University of Bath and subsequently joined Energy Conscious Design, (now ECD Partnership, London). His PhD work at the University of Cambridge developed new insights into the links between urban design and energy consumption. He acted as consultant on various projects; became a Director of Cambridge Architectural Research Ltd (1991) and of architectural practice CH+W Design (2015). He has been Director of the Martin Centre (2003-08) and Head of Department (2008-14).

Koen Steemers's expertise is based on being a registered architect (CH+W Design); environmental design consultant (Director of CAR Ltd); consultant to UN-HABITAT; President of PLEA (Passive & Low Energy Architecture international association); Fellow of Jesus College, Cambridge; Guest Professor at Chongqing University, China and at Kyung Hee University, Korea. He has extensive research assessment experience, including two

stints on the UK Government's research reviews and as deputy Chair of the Hong Kong Research Assessment Panel 2014. He is currently on the UK Green Building Council *Healthy Homes* task group.

Koen Steemers heads a team of 14 researchers in the *Behaviour and Building Performance* (BBP) Centre. He coordinates the MPhil course in Architecture and Urban Studies and supervises PhD students. He has produced over 200 publications (with over 4000 citations), including 10 books ranging in subject matter from *Sustainable Urban and Architectural Design* (2006) to *Daylight Design of Buildings* (2002).

See opposite page for an abstract of Koen Steemers's keynote lecture. This lecture has been recorded and can be viewed [online](#).

**right:**

The map illustrates the distribution of the predicted values for roof solar renewable energy potential in London. The results show that ca. 70% of the solar potential for both roof and façade areas can be explained by a combination of urban form descriptors. Using spatial data and a GIS platform, these descriptors are relatively easy and quick to compute, which makes this approach a good contender for rapid analysis of urban solar potential at the neighbourhood and city scales.

From: J.J. Sarralde, D.J. Quinn, D. Wiesmann, K. Steemers, (2015), 'Solar Energy and Urban Morphology', *Renewable Energy*.

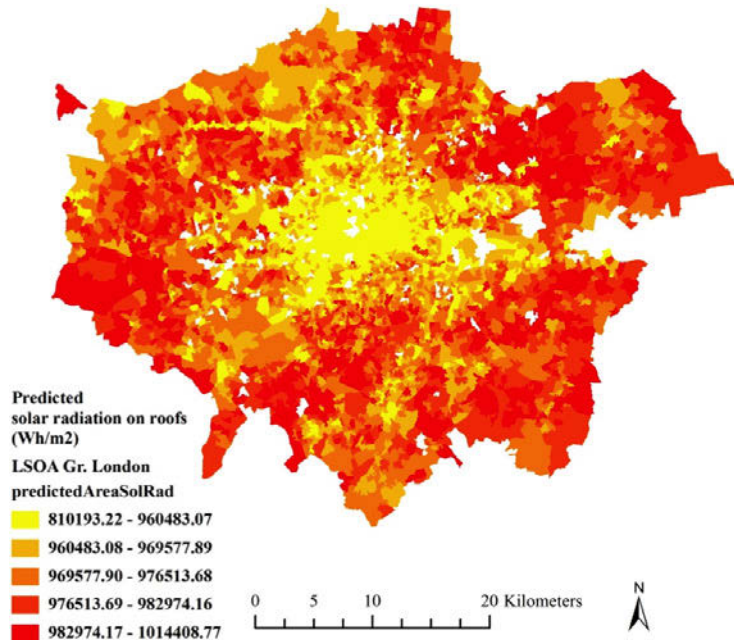
**below:**

Variable heights and spacing at a high density (FAR=7.2) achieves the same sky view factor (SVF=0.3) as a regular array at one-fifth of the density (FAR=1.44).

From: V. Cheng, K. Steemers, et al. 'Urban Form, Density and Solar Potential', *PLEA 2006*

### 'Urban Form and Energy: Systems Thinking and Environmental Diversity'

Through the lens of 'systems thinking' (the theme of SBE16 Zurich) this presentation explored the environmental performance of urban form. It reviewed analytical techniques ranging from simplified strategies to integrated simulation. Although simple rules have been influential, they are often too simplistic to reveal complex, real-world, interconnected or diverse strategies. More sophisticated and dynamic analysis of urban form, particularly in relation to energy performance and outdoor comfort, has revealed the value of environmental diversity. In place of thinking about optimal solutions, the notion of spatial and temporal diversity improves environmental performance. This is demonstrated through the analysis of urban form where diverse designs outperform regular urban arrays in terms of energy use and outdoor comfort. Finally, using a systematic integrated modelling approach that assess urban form with respect to socio-economic, land use, transport and building design was presented.

The approach is to test current and future development scenarios (e.g. compact form versus sprawl) over the longer term and to identify the relative energy consequences. Key results are:

- At an aggregate and regional level, urban scenarios have a modest relative impact on energy.
- The scenarios change the spatial distribution of energy demand which has implications for energy supply (e.g. compact form - CHP, ground source systems and networks; versus sprawl - solar and wind).
- The uptake of retrofit technologies, occupant behaviour and expectation, and the rate of new-build have a large impact on energy demand for all scenarios.

'Systems thinking' reveals complex and diverse strategies regarding: a) social v. technical solutions, b) individual behaviour v. urban systems, and c) static v. dynamic characteristics. Such richness of systems thinking can be explicitly embraced for sustainable urban design.

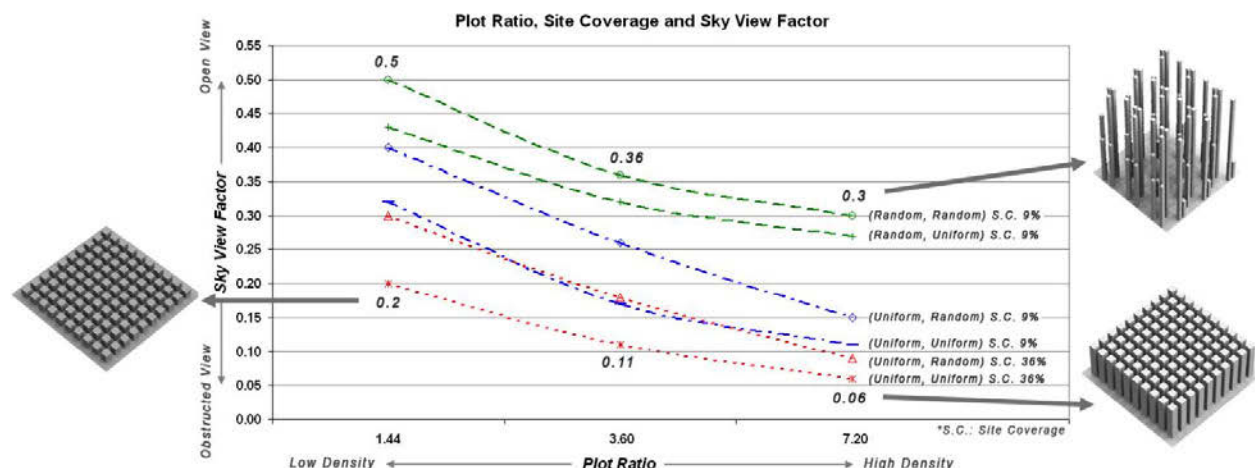



### Peter Edwards

Singapore-ETH Centre for Global Environmental Sustainability

Peter Edwards took the natural science tripos at Cambridge University, specializing in botany, and graduated in 1970. In 1973 he obtained his Ph.D. degree, also from Cambridge, for a thesis entitled *Nutrient cycling in a New Guinea montane forest*. He was a lecturer/senior lecturer in ecology at the University of Southampton, England, from 1973-1993. Since 1993 he has been professor of plant ecology at the Swiss Federal Institute of Technology (ETH), where he has also served as chairman of the Department of Environmental Systems Science.

Peter Edwards has always had a strong interest in the application of science and technology for better policy. He was a founder and first executive secretary of the Institute for Ecology and Environmental Management, a professional organization for environmental practitioners. At ETH he was faculty coordinator and member of the executive board of the Alliance for Global Sustainability, a research partnership between several leading universities.

He is author of around 300 refereed scientific papers and author/editor of several books covering a wide range of environmental topics including ecosystem processes, insect-plant interactions, environmental management and biodiversity. His recent research has focused particularly on large-scale processes in terrestrial ecosystems, including interactions between large herbivores and vegetation, the dynamics of vegetation on the flood plains of large rivers, and the role of biodiversity in agricultural landscapes.

See opposite page for an abstract of Peter Edwards's keynote lecture. This lecture has been recorded and can be viewed [online](#).

**right:**

Aerial view of the Ciliwung River in Jakarta, Indonesia.

**below:**

Visualization tools in 'Value Lab Asia' at the Singapore-ETH Centre.



Images © FCL, Singapore-ETH Centre.

### 'Future Cities Laboratory: Innovative Research for Sustainable Cities'

Asia's urban population will grow by more than one billion people by 2050. ETH's Future Cities Laboratory (FCL), which forms part of the Singapore-ETH Centre, was established to provide knowledge and ideas to make these rapidly growing cities more sustainable and resilient. This lecture presented examples of the kinds of problem-oriented research undertaken at FCL, and the challenges of putting new knowledge into practice.

One FCL study set out to quantify the materials used to transform Singapore into a modern city, and examined the environmental and other impacts. In total, some 2000 million m<sup>3</sup> of material were required for land reclamation, which was obtained by importing sand from other countries, topping of hills in Singapore and dredging.

A second study developed a new approach to urban river rehabilitation. The river studied was the heavily polluted Ciliwung River in Jakarta, which floods regularly, causing untold misery to residents. The multi-disciplinary research team used a combination of hydrologic, hydrodynamic and 3-D

landscape modelling to assess the consequences of potential interventions in the urban landscape. Working closely with stakeholders, they developed design scenarios aimed at restoring the riparian ecosystems and improving the quality of life for local communities.

A third example focused on the extensive areas around many Asian cities where urban and agricultural forms of land use coexist (a settlement form known as *desakota*, which can easily develop into an extended urban sprawl). The aim of this project was to develop new forms of urban design that provide the benefits and quality of an urban life-style while preserving agricultural communities.

An important part of the 'glue' holding these projects together are the superb facilities provided by the 'Value Lab Asia' for modelling and presenting 3-D and more-dimensional data. These provide not only an essential research tool, but also a means for translating research into solutions that practitioners can use. We argue that this kind of transdisciplinary research, engaging stakeholders at all stages of the process, will be essential for achieving a sustainable urban future.







**Chrisna du Plessis**  
University of Pretoria

Chrisna du Plessis is a Professor in the School for the Built Environment, University of Pretoria, South Africa. She was formerly Principal Researcher at Council for Scientific and Industrial Research (CSIR) Built Environment in Pretoria, South Africa. Her work focuses on sustainable human settlement and the application of sustainability science in the built environment.

Chrisna du Plessis is known for her work on the evaluation of policy and research strategy for sustainable building and construction in developing countries, and is currently concentrating on urban sustainability science at both theoretical and technical levels. Her main expertise is the development of trans-disciplinary research and development programs that follow a complex systems approach to the development of human settlements as sustainable social-ecological systems.

She studied architecture at the University of Pretoria, South Africa, obtained a PhD in Urban Sustainability from the University of Salford, UK, and was awarded an honorary doctorate in technology from Chalmers University of Technology in Gothenburg.

Chrisna du Plessis represented South Africa in the Earth Charter drafting and consultation process and contributed to several national and international policy and strategy initiatives on sustainable settlements. She was lead author of the United Nations Environment Program's *Agenda 21 for Sustainable Construction in Developing Countries* and is Theme Coordinator: Sustainable Construction for the International Council on Research and Innovation in Building and Construction.

See opposite page for an abstract of Chrisna du Plessis's keynote lecture. This lecture has been recorded and can be viewed [online](#).

### **'Thriving in the Symbiocene: A Message of Hope'**

We are living through the end of the world as we knew it. Everything that has been familiar about our planet and our world is changing and we will need to change with this, or become extinct. This is not a bad thing. In the breaking down of old systems, we have been given an opportunity to change. And the biggest change we need to make is in the stories we tell ourselves. We can remain stuck in old stories of separation and denial, or start telling new stories of collaboration, cooperation and symbiosis in which humans are restored to their natural place as members of the community of life whose purpose is to create an abundant and thriving future in which all species can flourish for all time. We can do this if we do more than slow down the degeneration of our systems, and start working on developing regenerative systems that can adapt and transform to meet the unknown conditions of our future world. If we understand that what needs to be sustained is the functional integrity of the global social-ecological system; and

what needs to be developed is the adaptive capacity and evolutionary potential of this system. If we shift the basis of our relationship with planetary systems and other members of the web of life, including other humans, from exploitation to adding value, doing more good, instead of less bad. If we shift to improving and enriching our relationships with each other, with nature, with our neighbours and future generations; focusing on contributing, adding to and giving back.

As designers and engineers our role is to become the matchmaker, mediator and facilitator of the dialogue; the narrator constructing the story of a different future; and the mentor leading the stakeholder team to another way of being. But to do this, we need to start with self, becoming impeccable warriors who come to the table with a soft and open heart, with compassion for the fears and failures of ourselves and others, yet fierce in our determination to create a better future.



**left:**

Lecture by Chrisna du Plessis,  
© ETH Zurich, Chair of Sustainable  
Construction 2016.



### Serge Salat

Urban Morphology and Complex Systems Institute, Paris

Serge Salat is an urban planner, a scientist in the science of complexity, an art historian and an internationally recognized architect/artist. He is the founder and President of the Urban Morphology and Complex Systems Institute based in Paris.

Serge Salat has been seminal in applying the science of complexity to cities. He has authored more than 20 books on art and architecture, as well as more than one hundred publications and communications. He has opened the way in introducing physics far away from the equilibrium, fractals, as well as network analysis and complexity science to a better understanding of cities.

He is a practicing architect and city planner and advises international organizations such as United Nations, The World Bank, AFD (French Agency for Development) and CDC (Caisse des Dépôts et Consignations), on strategic transitions of urbanization in particular in China, where he brings a unique integration of scientific skills, economic, financial and governance competence with his

experience of designer of large scale projects to advise on national policies as well as on specific projects. He is one of the authors of the Fifth IPCC assessment report.

Born in 1956, he graduated from École Polytechnique with a master of mathematics and physics (Paris, 1979), from Institut d'Études Politiques (Paris, 1982), and from École Nationale d'Administration (Paris, 1984). He obtained a Ph.D. in Economics (Université Paris IX Dauphine, 1979–82); a Ph.D. in Architecture (École d'Architecture de Paris La Villette, 1989); and a Ph.D. in History and Civilizations (EHESS, Paris, 2010).

See opposite page for an abstract of Serge Salat's keynote lecture. This lecture has been recorded and can be viewed [online](#).

**right:**  
London subway closeness centrality map of subway stations (topological distance in the network of a given station to all the others).

**below:**  
Greater London jobs density peaks at 150.000 jobs per km<sup>2</sup> in the City of London and is aligned with transit accessibility.

London Gross Value Added per km<sup>2</sup> ranked from the most economically productive urban land to the less productive shows an inverse power law where 20% of London urban land produces 67 % of the city's GDP.

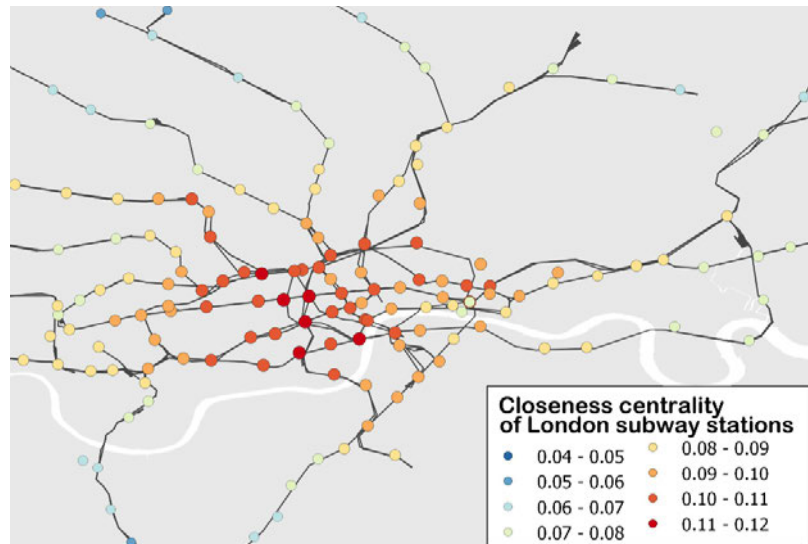

Images © Urban Morphology and Complex Systems Institute.

**'Systems Thinking for Integrated Sustainable Urban Planning'**

Systems thinking and integrated spatial planning are key for achieving resource efficiency. Articulated densification and strategic intensification of cities reduces the need for resources while increasing economic growth and social inclusiveness through enhanced access to jobs opportunities.

Scientific evidence derived from cross analysis of dozens of cities shows that resource efficient urban forms create cities that are more competitive, with lower transport and housing costs, with high quality neighborhoods, with lower infrastructure costs and lower CO<sub>2</sub> emissions, cities that are resilient to natural hazards. Doubling jobs density increases by 5 to 10% economic productivity; e.g. 60% of New York office space is on 9 km<sup>2</sup> (1% of NYC land area). Enhanced access and mobility lowers transport and housing cost: e.g. in Hong Kong, 83% of jobs are within 1 km of mass transit; in USA, residents near Transit Oriented Development (TOD) stations spend 37% of income on transport and housing against 51% for other people.

These resilient and efficient cities share common features of self-organized complex systems. They are networks of relations from which locations emerge. They have no characteristic scale but show wide variations of sizes, densities, concentrations, strengths of connections (e.g. volume of commuting flows in transit lines), and centralities in their subway networks across urban space. Ubiquitous power laws order the frequency of sizes, densities, connectedness, and, in some cases, centralities that are referred in physics as universality classes. For example, the frequency of plots of a given size follows in NY, Paris, Hong Kong a power law of exponent - 0.5. The size of parks also follows power laws in Paris, NY, Rome, Barcelona. GDP creation is highly concentrated following a Pareto principle where 20% of the urban land produces 80% of the city GDP (e.g. London, Zhengzhou). Jobs densities are highly concentrated with a hierarchy exponent of the power law of -1, e.g. 1.5 million jobs in 15 km<sup>2</sup> in London and NYC. A long term vision of the city shape, and highly granular planning with wide variations of FARs at small block scale, like in NYC and Singapore, completed by flexibility to accommodate market changes, allows shaping these efficient city forms with a delicate balance of planning and market.

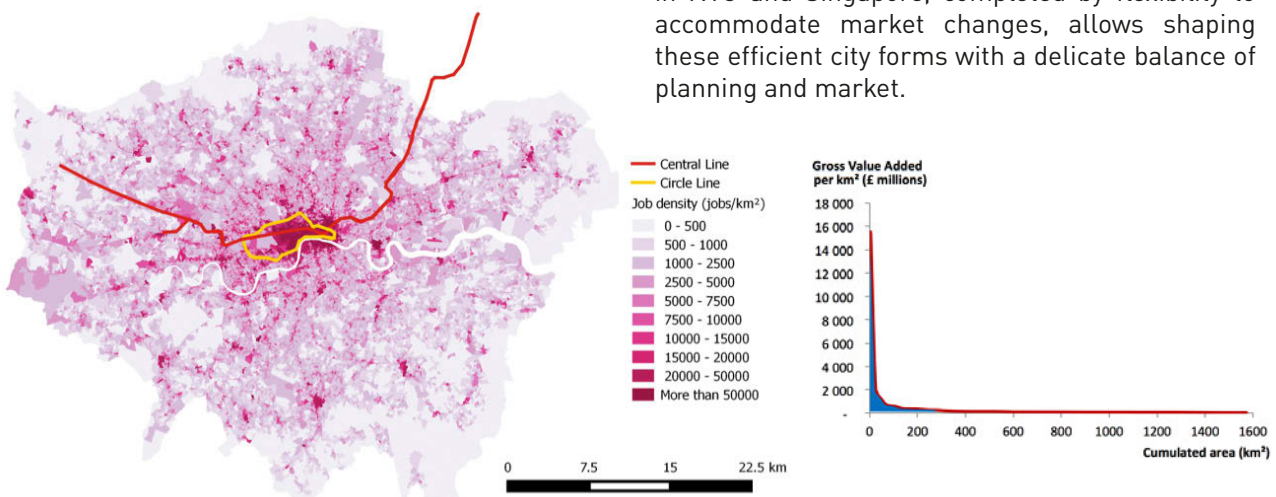



### Jens Feddern

Siemens Building Technologies

Jens Feddern is heading the Center of Competence Building Performance and Sustainability for South and West Europe. This organisation is acting as a service provider with the specific knowledge and experiences in the different regions and is assuring the proper risk management especially for energy efficiency and modernization projects.

He holds a degree in electrical engineering and executive master in business studies. Jens Feddern has been working for Siemens since about 16 years in various functions in product development, business development and global account management with a specific track record of more than 10 years in the life science industry.

See opposite page for an abstract of Jens Feddern's keynote lecture. This lecture has been recorded and can be viewed [online](#).

#### below:

Digitalisation in buildings – how to transform data into meaningful information and into customer value.

#### opposite page:

Comprehensive data analytics for optimisation tasks – detect the potential and supervise the results.

The path to maximise building performance – holistic view on the entire building infrastructure and beyond.

Images © Siemens Building Technologies.

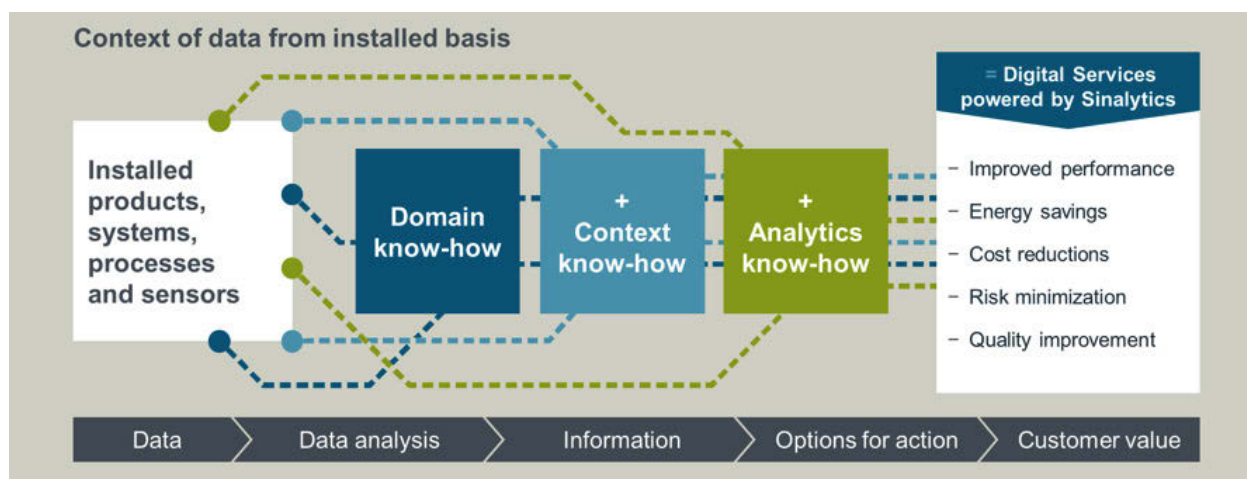

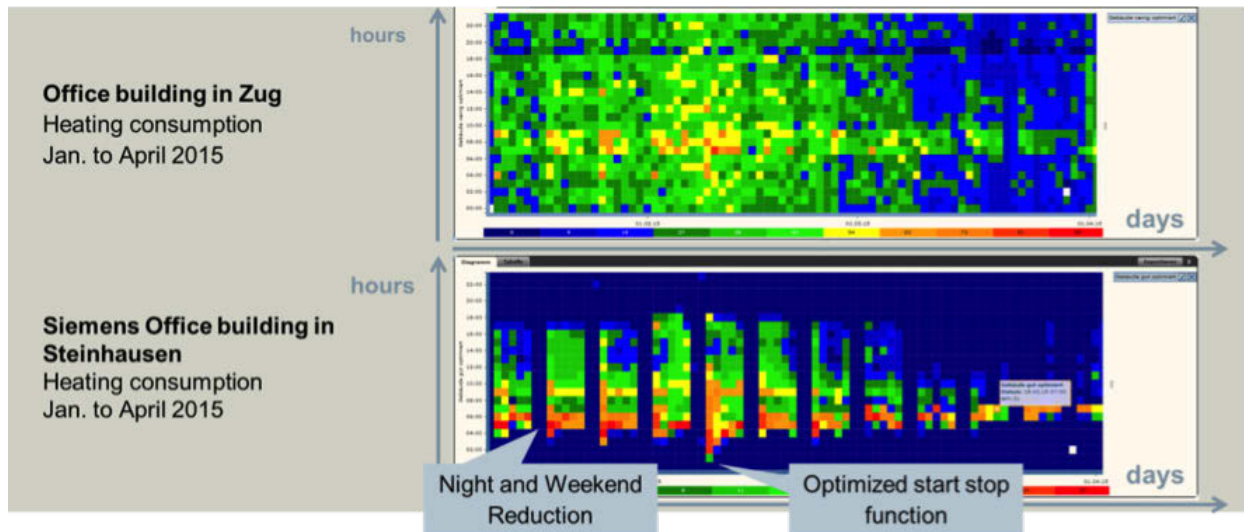

### 'Expanding Boundaries: Systems Thinking for Building Performance'

Europe's building stock has a significant modernisation potential, but less than 1% is explored year over year. The key to success is not a one-to-one replacement of equipment that is at the end of the life cycle or even broken, but a holistic analysis and modernisation of the entire building infrastructure whilst considering actual user needs.

80 % of a building's life cycle costs occur during ongoing operation but significant decisions are already made during construction. The planning must rely on numerous assumptions about the future use and operation and technical innovation is increasing while the buildings are getting older.

To get to know exactly the current and future needs comprehensive data collection provides a solid foundation to maximise the building performance during ongoing operation.

Big Data or even better Smart Data provide the foundation for systematic analysis and predictions. This analysis is based on thorough technical understanding, detailed knowledge about the individual application and comprehensive analytic methodologies.

This keynote lecture has shown the Siemens path to maximise building performance from transparency, over optimisation to comprehensive modernisation. The digitalisation in buildings was highlighted and as a consequence the digital transformation of services was explained. Several examples and case studies have demonstrated the successful application in practice.

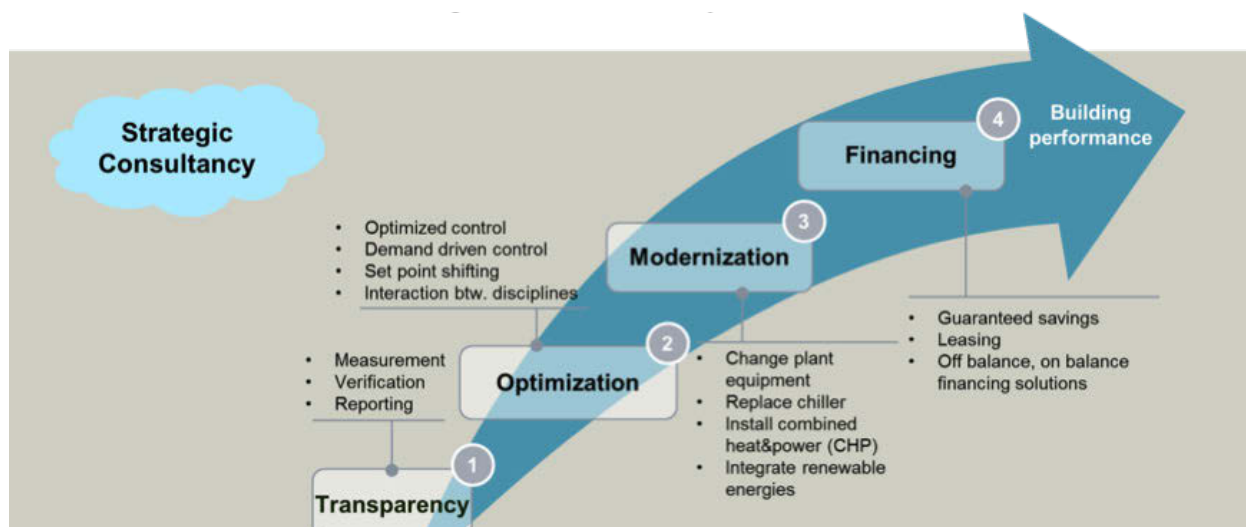



# 04

## Panel Discussion

### Smart Humans or Smart Meters?

38

The role of human and technology for a future sustainable built environment





### Smart Humans or Smart Meters?

The role of human and technology for a future sustainable built environment

#### Chair:

Niklaus Kohler (em. Prof. KIT)

#### Participants:

Annette Aumann (City of Zurich)  
 Chrisna du Plessis (University of Pretoria)  
 Jens Feddern (Siemens Building Technologies)  
 Eike Roswag-Klinge  
 (Ziegert | Roswag | Seiler Architekten Ingenieure)

This discussion brought representatives of science, industry, planning and public administration to the table. While they shared the concern for a sustainable future of the built environment, speakers – based on their respective field – presented varying views on how to achieve it. Following the overall topic of the conference, system synergies despite different approaches as well as the influence of the human factor were discussed. The following questions are linked to the central issue of the discussion:

- Can the optimisation of technological systems pave the way to sustainability?
- What is the relevance and impact of public policies and guidelines?
- Which potential or risk does the increasing digitalisation and infomatisation of both building construction and operation bear?
- Finally, what about the human? Is the individual user controlling or controlled by a technologically intricate and therefore sustainable built environment?

The discussion has been recorded and can be viewed [online](#).



Panel Discussion  
G3



**opposite page:**  
Participants of the panel discussion  
and signage poster.

**right:**  
Chrisna du Plessis  
Eike Roswag-Klinge  
Annette Aumann  
(top to bottom)

Images © ETH Zurich, Chair of  
Sustainable Construction 2016.



# 05

## Conference Papers

<b>Distributed Energy Systems and Infrastructure</b>	<b>46</b>
<b>Optimal Energy Technology Networks in Spatial Energy Planning in Austrian City Quarters</b>	
S. Maier, H. Dumke, M. Eder, J. Fischbäck, M. Malderle, E. Rainer	46
<b>Energy and the City: Investigating Spatial and Architectural Consequences of a Shift in Energy Systems on District Level in a Summer School</b>	
A. Willmann, S. Cisar, Z. Nagy, A. Schlueter	52
<b>Optimal Energy System Transformation of a Neighbourhood</b>	
R. Wu, G. Mavromatidis, K. Orehounig, J. Carmeliet	58
<b>Matching Renewable Energy Production and Consumption by Market Regulated Demand Site Management (DSM)</b>	
T. Schluck, R. Bühler, S. Sulzer, M. Sulzer	64
<b>Holistic Optimization of Urban Morphology and District Energy Systems</b>	
C. Waibel, R. Evins, J. Carmeliet	70
<b>Built from Determinants of Urban Land Surface Temperature: A Case of Mumbai</b>	
S. Mehrotra, R. Bardhan, K. Ramamritham	78
<b>Integration of Outdoor Human Comfort in a Building Energy Simulation Database Using CityGML Energy ADE</b>	
S. Coccolo, D. Mauree, J. Kämpf, J.-L. Scartezzini	84
<b>Multi-Scale Modelling to Assess Human Comfort in Urban Canyons</b>	
D. Mauree, S. Coccolo, J. Kämpf, J.-L. Scartezzini	90
<b>Assessing the Performance and Resilience of Future Energy Systems at Neighborhood Scale</b>	
J. A. Fonseca, A. Schlueter	96
<b>Facilitating Climate Adaptive Urban Design – Developing a System of Planning Criteria in Hungary</b>	
F. Szkordilis, M. Kiss, L. A. Égerházi, D. Kassai-Szoó, Á. Gulyás	102
<b>Comparison of District Heating Systems and Distributed Geothermal Network for Optimal Exergetic Performance</b>	
P. M. Falk, F. Meggers, P. Stephan, F. Dammal	108
<b>Campus as a Lab: Building- and System-Level Air Movement Investigations</b>	
E. Teitelbaum, S. Urano, L. Conlan, A. Percival, J. Hinson, F. Meggers	114
<b>Uncertainty and Sensitivity Analysis for the Optimal Design of Distributed Urban Energy Systems</b>	
G. Mavromatidis, K. Orehounig, J. Carmeliet	122
<b>Does Roof Shape Matter? Solar PV Integration on Roofs</b>	
N. Mohajeri, D. Assouline, B. Guiboud, J.L. Scartezzini	130
<b>LCA as Key Factor for Implementation of Inertia in a Low Carbon Performance Driven Design: The Case of the Smart Living Building in Fribourg, Switzerland</b>	
A. Brambilla, E. Hoxha, T. Jusselme, M. Andersen, E. Rey	136
<b>Tuning Energy Performance Simulation on Behavioural Variability with Inverse Modelling: The Case of Smart Campus Building</b>	
L. C. Tagliabue, M. Manfren, A.L.C. Ciribini, E. De Angelis	142
<b>Strategic Planning for the Transformation of a University Campus Towards Smart, Eco and Green Sustainable Built Environment: A Case Study from Palestine</b>	
S. Abu-Eisheh, I. Hijazi	148
<b>Introduction of a Dynamic Interpretation of Building LCA Results: The Case of the Smart Living (Lab) Building in Fribourg, Switzerland</b>	
E. Hoxha, T. Jusselme, M. Andersen, E. Rey	154
<b>NEST – Exploring the Future of Buildings</b>	
P. Richner, R. Largo	160
<b>What Should a Building be Controlled for? Ask the Occupants!</b>	
Z. Nagy, F. Y. Yong, A. Schlueter	166
<b>Prediction of Users' Behaviour Patterns Impact on Energy Performance of a Social Housing in Cremona, Italy</b>	
L. C. Tagliabue, M. Manfren, A.L.C. Ciribini, E. De Angelis	172
<b>Towards Sustainable Occupant Behavior and Organizational Change</b>	
D. V. Keyson, T. J. Jaskiewicz	178
<b>Modelling Load Profiles for the Residential Consumption of Electricity Based on a Milieu-Oriented Approach</b>	
N. Haufe, M. Ziegler, T. Bednar	184

<b>A Methodology for Energy Audit for Commercial Buildings Using Machine Learning Tools</b>	
C. Deb, S. E. Lee, J. Yang, K. W. Shah	190
<b>Overheating Reduction of a Cold Formed Steel-Framed Building Using a Hybrid Evolutionary Algorithm to Optimize Different PCM Solutions</b>	
A. J. Figueiredo, R. Vicente, J. Kämpf, C. Cardoso, J.-L. Scartezzini, F. Rodrigues	196
<b>Model Predictive Control for Geothermal Borehole Depth Determination</b>	
H. Guo, F. Meggers	202
<b>Integrating Persuasive Technology in Prototypes of Interior Walls to Stimulate Behavioural Change</b>	
M. Mohammadi, C. Hammink, M. Dominicus, K. Hermans	208
<b>Toward an Integrated Platform for Energy Efficient Lighting Control of Non-Residential Buildings</b>	
A. Motamed, L. Deschamps, J.-L. Scartezzini	216
<b>Dynamic Energy Weighting Factors to Promote the Integration of Renewables into Buildings</b>	
L. Baldini	222
<b>Solar Energy Availability in Urban Densification Process Impact on Existing Buildings in a Swiss Case Study</b>	
C.S. Polo López, M. Sala, F. Frontini, L. C. Tagliabue, E. De Angelis, G. Pansa	228
<b>Towards Integrated Design Strategies For Implementing BIPV Systems into Urban Renewal Processes: First Case Study in Neuchâtel (Switzerland)</b>	
S. Aguacil, S. Lufkin, E. Rey	234
<b>From Design to Operation – Lessons Learned from the World’s First Passive-House Office Tower</b>	
C. Steininger, R. Toth	240
<b>An Integrated and Intelligent Way Towards Energy Management – The Cockpit</b>	
S. Lee, K. Shah, J. Yang, C. Deb	246
<b>Campus Sustainability Retrofits: A Multi-Criteria Site Selection Model for Low Impact Development (LID)</b>	
A. Kamal	252
<b>Life-Cycle Oriented Approaches</b>	<b>258</b>
<b>LCA Enhancement Perspectives to Facilitate Scaling up from Building to Territory</b>	
G. Sibiude, A. Mailhac, G. Herfray, N. Schiopu, A. Lebert, G. Togo, P. Villien, B. Peuportier, C. Valean	258
<b>LCA Applicability at District Scale Demonstrated Throughout a Case Study: Shortcomings and Perspectives for Future Improvements</b>	
A. Mailhac, G. Herfray, N. Schiopu, N. Kotelnikova-Weiler, A. Poulhes, S. Mainguy, J. Grimaud, J. Serre, G. Sibiude, A. Lebert, B. Peuportier, C. Valean	266
<b>Combining GIS Data Sets and Material Intensities to Estimate Vienna’s Building Stock</b>	
F. Kleemann, J. Lederer, H. Rechberger, J. Fellner	274
<b>A GIS-Based Approach for the Energy Analysis and Life Cycle Assessment of Urban Housing Stocks</b>	
A. Mastrucci, A. Marvuglia, E. Benetto, U. Leopold	280
<b>Geo-Dependent Heat Demand Model of the Swiss Building Stock</b>	
S. Schneider, J. Khoury, B. Lachal, P. Hollmuller	286
<b>Economic and Ecological Assessment of Cuban Housing Solutions Using Alternative Cement</b>	
Y. Cancio Diaz, S. Sanchez, F. Martirena, I.R. Sanchez, K. Scrivener, G. Habert	292
<b>A Sustainable Development Approach for Affordable Housing in Egypt</b>	
A. Mokhtar	298
<b>Environmental Implications and Opportunities of Digital Fabrication</b>	
I. Agustí-Juan, G. Habert	304

<b>A Novel Perspective on the Avoided Burden Approach Applied to Steel-Cement Making Joint System</b>	
M. R.M. Saade, M. G. da Silva, V. Gomes	310
<b>Air Dehumidification with Novel Liquid Desiccant System</b>	
J. Pantelic, E. Teitelbaum, S. Kim, H. Guo, A. Schlueter, A. Rysanek, F. Meggers	316
<b>Deep Renovations within Smart Asset Management</b>	
E. Nippala, T. Vainio	322
<b>A Multi-Criteria Approach for the Assessment of Housing Renovation Strategies</b>	
O. Pombo, K. Allacker, B. Rivela, J. Neila	328
<b>Business Case Study for the Zero Energy Refurbishment of Commercial Buildings</b>	
A. Greco, T. Konstantinou, H.R. Schipper, R. Binnekamp, E. Gerritsen, R. de Graaf, A. van den Dobbelsesteen	334
<b>Impact of Building Refurbishment Strategies on the Energetic Payback</b>	
A. Passer, C. Ouellet-Plamondon, P. Keneally, G. Habert	340
<b>Economic and Environmental Assessment of Building Renovation: Application to Residential Buildings Heated with Electricity in Switzerland</b>	
B. Périsset, S. Lasvaux, C. Hildbrand, D. Favre, S. Citherlet	346
<b>Environmental Effects of an Alpine Summit Tunnel</b>	
F. Gschösser, W. Purrer, P. Sander	352
<b>Selection of Environmental Datasets as Generic Data: Application to Insulation Materials within a National Context</b>	
J. D. Silvestre, S. Lasvaux, J. Hodková, J. de Brito, M. D. Pinheiro	360
<b>€office-LCC and LCA as Part of the Integrated Design Approach for a High Performance-Low Cost Office Building</b>	
L. Delem, R. Decuyper, O. Dartevelle	364
<b>Sustainable Stepwise Building Renovation</b>	
M. Lehmann, W. Ott	372
<b>Environment and Economy – An Alliance of Mutual Benefits in Residential Building</b>	
V. John, S.D.T. Schwarz, G. Habert	378
<b>A Framework for Life Cycle Assessment of Concretes with Recycled Aggregates in Large Metropolitan Areas</b>	
A. Yazdanbakhsh, L.C. Bank, T. Baez, I. Wernick, A. Hamidi	384
<b>Life Cycle Analysis of Recycled Aggregate Concrete with Fly Ash as Partial Cement Replacement</b>	
S. Marinković, G. Habert, I. Ignjatović, J. Dragaš, N. Tošić, C. Brumaud	390
<b>Eco-Efficiency of Construction and Demolition Waste Recycling in Chongqing, China</b>	
J. Wu, M. Hu, S. Shi, T. Liu, C. Zhang	398
<b>Efficiency of Using Recycled Fine Aggregate for a New Concrete</b>	
A. Katz, D. Kulisch	404
<b>The Cost and Environmental Impact of Service Life Extending Self-Healing Engineered Materials for Sustainable Steel Reinforced Concrete</b>	
P. Van den Heede, B. Van Belleghem, N. De Belie	408
<b>Eco-Mechanical Performances of UHP-FRCC: Material vs. Structural Scale Analysis</b>	
A. P. Fantilli, S. Kwon, H. Mihashi, T. Nishiwaki	414
<b>Low Carbon Cement: A Sustainable Way to Meet Growing Demand in Cuba</b>	
S. Sanchez, Y. Cancio, F. Martirena, I.R. Sanchez, K. Scrivener, G. Habert	420
<b>Life Cycle Assessment of Precast and Cast-In-Situ Construction</b>	
Y. H. Dong, L. Jaillon, C.-S. Poon	426
<b>Process Mapping and Preliminary Assessment of Life Cycle Impact in Indian Cement Plants</b>	
R. Gettu, S. Prakasan, A. Patel, V. Rathi, K. Nagrath, S. Palaniappan, S. Maity	430
<b>The Environmental Relevance of the Construction and End-Of-Life Phases of a Building: A Temporary Structure LCA Case Study</b>	
A. Arrigoni, D. Collatina, M. Zucchinielli, G. Dotelli	436
<b>Overcoming Obsolescence: A Case Study Renovation Building – Ideas on Reuse in Planning and Building Process</b>	
A. Hafner	442
<b>Resources in Buildings and Their Recycling Options</b>	
K. Krause, A. Hafner, S. Schäfer	448

<b>Life Cycle GHG Emissions from a Wooden Load-Bearing Alternative for a ZEB Office Concept</b>	
A. Houlihan Wiberg, T. Barnes Hofmeister, T. Kristjansdottir, B. Time	454
<b>Smart Regeneration of Public Utility Buildings</b>	
E. Arbizzani, P. Civiero, C. Clemente	460
<b>Demolition versus Deep Renovation of Residential Buildings: Case Study with Environmental and Financial Evaluation of Different Construction Scenarios</b>	
L. Wastiels, A. Janssen, R. Decuypere, J. Vrijders	466
<b>Retrofitting Measure vs. Replacement – LCA Study for a Railway Bridge</b>	
F. Gschösser, R. Schneider, A. Tautschnig, J. Feix	472
<b>Towards a Reliable Comparison between Environmental and Economic Cost of Swiss Dwellings: A Model with Building Materials' Service Life Uncertainty</b>	
I.-F. Haefliger, V. John, S. Lasvaux, E. Hoxha, A. Passer, G. Habert	478
<b>Integrated Approaches and Tools for Decision-Making</b>	<b>484</b>
<b>Engaging Stakeholders through Local Project Committees</b>	
G. Barbano, A. Moro	484
<b>Management of User and Stakeholder Interests in Multi-Criteria Assessments</b>	
H. Kreiner, A. Passer	490
<b>Business Model Innovation for Local Energy Management: A Systematic Methodology</b>	
E. Facchinetti, S. Sulzer	496
<b>Establishing Links for the Planning of Sustainable Districts</b>	
S. Cajot, N. Schüler, M. Peter, J. Page, A. Koch, F. Maréchal	502
<b>Which Additional Impact Categories Are Ready for Uptake in the CEN Standards EN 15804 and EN 15978? Evaluation Framework and Intermediate Results</b>	
K. Allacker, D. De Lathauwer, W. Debacker, W.C. Lam, K. Boonen	514
<b>Integrated Process for the Evaluation and Optimization of Buildings Performance</b>	
B. Daniotti, A. Pavan, D. Pasini, M.A. Chiozzi	520
<b>Critical Analysis of Sustainability Scoring Tools for Neighbourhoods, Based on a Life Cycle Approach</b>	
D. Trigaux, K. Allacker, F. De Troyer	526
<b>Building Occupancy Certification: Development on an Approach to Assess Building Occupancy</b>	
O. Guerra-Santin, T. Jaskiewicz, J. Doolaard, D. Keyson	532
<b>Renovation in Austria – Analysis of the Energy Performance Certificates between the Years 2006 and 2015 of the County Salzburg</b>	
M. Prieler, M. Leeb, T. Reiter	538
<b>Ecological Footprint Analysis of Canadian Household Consumption by Building Type and Mode of Occupation</b>	
C. Jouaneau, M. Dupuis, N. Grunewald, C. Ouellet-Plamondon	544
<b>Life Cycle Assessment as a Design Aid Tool for Urban Projects</b>	
C. Roux, G. Herfray, P. Schalbart, B. Peuportier	550
<b>From a Simple Tool for Energy Efficient Design in the Early Design Phase to Dynamic Simulations in a Later Design Stage</b>	
A. Miyamoto, D. Trigaux, T. Nguyen Van, K. Allacker, F. De Troyer	556
<b>Analysis of the Material-Related Design Decision Process in Flemish Architectural Practice</b>	
E. Meex, E. Knapen, G. Verbeeck	562
<b>Economic Flow Analysis of Construction Projects to Support Sustainable Decision-Making</b>	
D. Ioannidou, S. Zerbi, G. Habert	568
<b>Urban Planning and Solar Potential: Assessing Users' Interaction with a Novel Decision-Support Workflow for Early-Stage Design</b>	
E. Nault, L. Pastore, E. Rey, M. Andersen	574
<b>Increase the Efficiency in Sustainable Construction Using BIM</b>	
C. K. Druhmann, S. Ashworth, H. J. Bernegger	580

<b>The City Energy Analyst Toolbox V0.1</b>	
J. A. Fonseca, D. Thomas, A. Willmann, A. Elesawy, A. Schlueter	584
<b>A Method for Evaluating the Environmental Life Cycle Potential of Building Geometry</b>	
A. Hollberg, N. Klüber, S. Schneider, J. Ruth, D. Donath	590
<b>Economic Factors for Successful Net Zero Energy Refurbishment of Dutch Terraced Houses</b>	
A. Greco, T. Jonathan, B. Bogers, A. van den Dobbelsteen	596
<b>Sustainability Indicators for Buildings: Network Analysis and Visualization</b>	
L. C. Tagliabue, M. Manfren	602
<b>Integrating an Environmental and Socio-Economic Assessment Tool for the Development of Brownfield Development Projects</b>	
F. Cappai, D. Forgues, M. Glaus	608
<b>Survey Tool for the Built Environment</b>	
H. C. Leindecker, D. Mittermaier	616
<b>Innovative Materials and Components</b>	<b>622</b>
<b>Bio-Based Plastics-Composites for Sustainable Building Skins: Life Expectancy of Cladding Derived from Wind Suction Tests</b>	
D. Friedrich, A. Luible	622
<b>Holistic Observations on the Sustainability of High-Rise Building Facades</b>	
M. King, D. Geissbühler, U. Menti	628
<b>Integrated Approaches for Large Scale Energy Retrofitting of Existing Residential Building through Innovative External Insulation Prefabricated Panels</b>	
G. Iannaccone, G. Salvalai, M. M. Sesana, R. Paolini	636
<b>Limestone Calcined Clay Cement for a Sustainable Development</b>	
A. Favier, F. Avet, M. Antoni, K. Scrivener	644
<b>Design-Engineering-Based and Material-Based Improvement of Precast Concrete-Facade-Elements</b>	
M. Pätzold, F. Musso, Th. Lechner, O. Fischer, D. Heinz	650
<b>Life Cycle Assessment of a Post-Tensioned Timber Frame in Comparison to a Reinforced Concrete Frame for Tall Buildings</b>	
L. Cattarinussi, K. Hofstetter, R. Ryffel, K. Zumstein, D. Ioannidou, M. Klippel	656
<b>A New Route for Self-Compacting Clay Concrete</b>	
G. Landrou, C. Brumaud, G. Habert	662
<b>Improving Rammed Earth Walls' Sustainability through Life Cycle Assessment (LCA)</b>	
A. Arrigoni, D. Ciancio, C.T.S. Beckett, G. Dotelli	668
<b>Naturally Ventilated Earth Timber Constructions</b>	
A. Klinge, E. Roswag-Klinge, C. Ziegert, P. Fontana, M. Richter, J. Hoppe	674
<b>Environmental Assessment of Radical Innovation in Concrete Structures</b>	
S. Zingg, G. Habert, T. Lämmlein, P. Lura, E. Denarie, A. Hajjesmaeili	682
<b>Nanotechnology and Its Impact on Sustainable Architecture</b>	
N. Eisazadeh, K. Allacker	688
<b>Sustainable Insulation System Based on Fabrics</b>	
A. Saur, S. Kunz, D. Geissbühler	696
<b>Ecological Performance of Timber / Wood-Cement Compound Composite Slabs</b>	
M. Maeder, D. Zwicky	702
<b>Filter Facade</b>	
F. Oswald	708
<b>Spherical Motion Average Radiant Temperature Sensor (SMART Sensor)</b>	
E. Teitelbaum, J. Read, F. Meggers	714
<b>Environmental Optimisation of Shotcrete Applied at the Brenner Base Tunnel (BBT)</b>	
T. Cordes, F. Gschösser, K. Bergmeister	720
<b>Material Quantities and Embodied Carbon in Exemplary Low-Carbon Case Studies</b>	
C. De Wolf, K. Bird, J. Ochsendorf	726



Zurich, June 15-17 2016

Sustainable Built Environment (SBE) Regional Conference

## Expanding Boundaries: Systems Thinking for the Built Environment



### OPTIMAL ENERGY TECHNOLOGY NETWORKS IN SPATIAL ENERGY PLANNING IN AUSTRIAN CITY QUARTERS

S. Maier<sup>2\*</sup>, H. Dumke<sup>1</sup>, M. Eder<sup>2</sup>, J. Fischbäck<sup>2</sup>, M. Malderle<sup>3</sup>, E. Rainer<sup>3</sup>

<sup>1</sup> Department of Spatial Planning, Vienna University of Technology, Karlsplatz 13,  
A-1040 Vienna / Austria

<sup>2</sup> Institute for Process and Particle Engineering, Graz University of Technology, Inffeldgasse 13/3,  
A-8010 Graz / Austria

<sup>3</sup> Institute for Urbanism, Graz University of Technology, Rechbauerstraße 12/II,  
A-8010 Graz / Austria

\*Corresponding author; e-mail: [stephan.maier@tugraz.at](mailto:stephan.maier@tugraz.at)

#### Abstract

High energy demands of urban areas force energy planning and spatial planning in Europe to foster closer links with each other's discipline. Besides an open ground for common actions fundamental research is needed to extend knowledge and space about what the performance can look like.

The paper discusses fundamental research on energy demand and supply issues of cities and the influences on city development due to the interdependencies between living spaces. Two Austrian city quarters were chosen as reference cases, one of each located in the Austrian cities Graz and Vienna. These reference cases shall afterwards support future smart city developments considering city planning as an interdisciplinary process of integrating spatial and energy planning as a whole.

Process Network Synthesis (PNS) is used to find optimal energy technology networks to supply city quarters. With this method a variety of locally possible technologies can be considered for their application. Different characteristics of cities, as there were (resource) limits, ethical aspects and natural boundaries can be considered as well as financial aspects. The outcome helps to design future pathways of cities to an integrated sustainable development.

#### Keywords:

Spatial energy planning; process optimisation; urban energy systems; use of renewable energy

## 1 INTRODUCTION

Development of energy frameworks in urban areas depend on the respective context. Individual settings like geographical location, interests of local inhabitants or settlement densities can form the city in many ways.

Local energy planning is not always managed in an optimum way. Options must be found to rethink and rebuild existing parts of cities and build new city quarters only after identifying and jointly applying typically separated planning

approaches. From a steering perspective, both the spatial and the social policy triggers for entire city quarters clearly need more future attention although the coordination of both approaches are a "hard candy" in daily implementation practise. Energy planning and spatial planning need a common ground to converge both disciplines in an integrated spatial energy planning [1]. The existence of many approaches saving resources and making cities more sustainable de Jong et al. recently gave a broad overview [2].

This paper discusses an integral part of such a planning approach, the search for optimal energy systems for cities [3]. This optimisation is part of a project trying to find a contradictable guideline for an integrated spatial energy planning for city quarters. Fig.1 shows the two cities with the highlighted city quarters selected for case study areas. Both are located in the two Austrian cities Vienna and Graz. Both cities are constantly growing and consequentially concentrate energy demands.

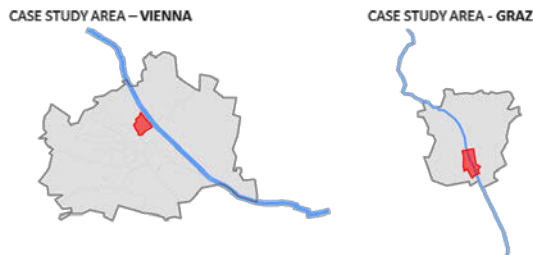

Fig. 1: Case study areas Vienna and Graz.

The settlement structure in the city quarter in Vienna is denser than that of Graz. Vienna has a well-established gas- and district heat grid. In both city quarters, green and brownfield areas are located. Due to the constant population growth these areas are a welcomed potential to expand the cities to handle the increasing demand for housing in the cities [4]. Both test areas were selected carefully in order to cover and respect various mixes of densities, existing settlement types, but also some projects that are yet unbuilt.

## 2 METHOD

Process Network Synthesis (PNS) is a method to optimise material and energy flows in finding combinatorially feasible structures in and for specific systems. This method is a further development of the p-graph method, a process graph framework based on combinatorial algorithms for process synthesis [5].

Capacities of technologies as well as availability, amount and quality structure of materials are user-defined. The optimisation was carried out with the software tool PNS Studio [6]. For the application of optimal energy technology systems for cities a discussion process about all locally available resources and implementable technologies was required. Moreover, the specific demand of products, all included mass- and energy flows, investment and operating costs of the whole infrastructure, cost of raw materials, transport and selling prices for products were defined.

With this information in PNS Studio a local maximum technology system could be created and all feasible maximal structures can be generated. The tool uses a branch-and-bound

algorithm to create an optimum structure out of the maximal structure. For this application the revenue for the whole system was set as target value to find the economically most feasible technology system.

## 3 STUDY AREAS FRAMEWORK

The following describes the framework of the case study areas. Because the aim of the work is to find an optimal energy system for the year 2030 it includes assumptions made for changes which seem to most likely be influencing the energy demand from 2015 until 2030.

The sizes of the study areas are 513 ha of Graz and 694 ha in Vienna. In the study area in the city of Graz the number of 21,500 inhabitants is predicted to grow to approximately 31,000 inhabitants (9,300 just due to developments in two green and brownfield areas). The area is located South, along the river Mur, in a very inhomogeneous area of grassland, fields, single-family houses, multi-storey houses, garden plots and industry.

The number of inhabitants in the second study area in Vienna is predicted to grow from 105,000 to more than 142,000 inhabitants (32,000 due to developments in two former railway areas). The area is located North of the central city district along the right bank of the river Danube in a very homogenous area of mainly multi-storey houses except the former railway areas.

More energy demand for building developments due to a growing population in the cities and growing electricity demand for electric cars as well seem to be very likely on the one hand but better insulated housing means less energy consumption (-50% for heating demand) on the other hand. Considering this the assumptions shown in Fig. 2 were made for the year 2030.

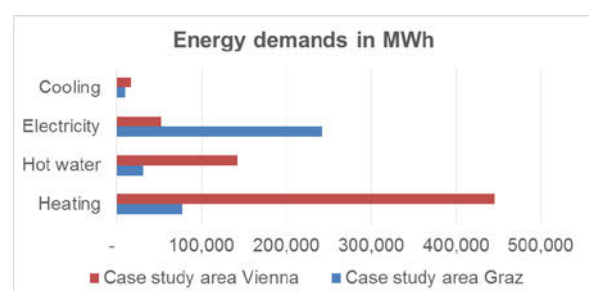

Fig. 2: Energy demands in case study areas.

The pre-calculations also included energy needs for mobility, where electricity need for electric cars was part of the electricity demand in PNS. All 2030 benchmarks also contained moderate "savings paths" in heat consumption, both output of deep thermal retrofit measures, but also from the growing number of entirely new buildings with low or passive house energy standards.

### 3.1 Maximal energy technology network

Beside energy demand also the respective resource availability for the year 2030 was assumed.

Both cities do have gas and district heat, in Vienna it is available area-wide. In Graz the spatial structure is very inhomogeneous. The northern part of the study area is mainly connected to district heat whereas the southern part is mainly connected to the gas net. In-between a mix of both or no network is accessible. Existing infrastructure and possible expansions were allowed in each quarter.

Geothermal energy could be accessed at a total of building area about 133 ha in Graz and 297 ha in Vienna. For solar thermal and photovoltaic 319,000 m<sup>2</sup> of roofs is the realistic potential in Graz and 1.6 Mio. m<sup>2</sup> that of Vienna.

Biomass for energy (grass, short rotation, green cuttings and bio waste) which is still not in use could be just found in Graz.

The maximal energy technology system includes central technologies (to supply parts or the whole quarter centrally) as following:

- Biogas fermentation
- Biogas cleaning
- Biogas supply station
- Combined heat and power
- Gas burner
- Pellet burner

Decentral technologies (to supply sub-quarters directly within sub-quarters):

- Air conditioning
- Combined heat and power
- Gas burner
- Geothermal heat or cooling
- Pellet burner
- Photovoltaic system
- Solar thermal collector for domestic hot water
- Solar thermal collector with Storage for domestic hot water and heat

Tab. 1 gives an overview about the baseline scenario 0-0 for the status quo of the year 2015 and 2030. The scenarios 0-1-0 to 0-1-6 include restrictions and changes of resource cost for the year 2030. Scenario 0-1-0 2015 includes basic energy demands of the city quarters in the year 2015 where population, densification, insulation and electric mobility of the cities are likely to be on a lower level than the predicted fifteen years later.

0-0 2015	<b>Baseline open – status quo 2015:</b> no further densification / development, no growing population, no insulation, no electric mobility
0-1-0	<b>Network restrictions – status quo</b>

2015	<b>2015:</b> based on scenario 0-0 2015, but district heating and gas grid just possible in quarters where it is better extendable for practical reasons; geothermal energy just possible in quarters with one-family houses and new developments where it could be installed without too many hindrances
0-0 2030	<b>Baseline open:</b> no further variation
0-1-0 2030	<b>Network restrictions:</b> based on scenario 0-0 but district heating and gas grid just possible in quarters where it is better extendable for practical reasons; geothermal energy just possible in quarters with one-family houses and new developments where it could be installed without too many hindrances
0-1-3 2030	<b>Purchase price variation natural gas:</b> based on scenario 0-1-0 but variation natural gas purchase price
0-1-4 2030	<b>Purchase price variation district heat:</b> based on scenario 0-1-0 but variation of existing district heat purchase price
0-1-5 2030	<b>Purchase price variation wood pellets:</b> based on scenario 0-1-0 but price variation wood pellets purchase price
0-1-6 2030	<b>Renewable energy goal:</b> based on scenario 0-1-0 but fixed minimum renewable energy share 2030 (Graz: 60%; Vienna: 30%)

Tab. 1: Scenario description.

## 4 RESULTS

### 4.1 Optimal energy system (baseline open scenarios 0-0)

In the test area of Graz, the heat demand in the baseline scenario is mainly covered with pellets (in scenario 0-0 2015: 76%; in 0-0 2030: 47%). The rest is biogas and natural gas used in central combined heat and power plants and gas burners (in both scenarios: 58 % of total gas consumption is biogas). The total share of renewables for the total energy demand is more than 90% in 0-0 2015 and more than 75% in 2030. Photovoltaic installations cover 49% of the electricity demand in 2015. This drops to 41% coverage in 2030.

In the test area in Vienna, the main resource to cover the energy demand is natural gas (in scenario 0-0 2015: 98%; in 2030: 97%) used in central and decentral combined heat and power plants. The rest of the heat (2% to 3%) and the cooling energy (100%) is provided by geothermal energy.

<b>Technologies test area Graz</b>		<b>Scenario</b>	<b>0-0 2015</b>	<b>0-1-0 2015</b>	<b>0-0 2030</b>	<b>0-1-0 2030</b>	<b>0-1-3 2030</b>	<b>0-1-4 2030</b>	<b>0-1-5 2030</b>	<b>0-1-6 2030</b>
Gas burner	central		0%	0%	0%	0%	0%	0%	35%	17%
Gas burner	decentral		4%	5%	14%	14%	0%	14%	23%	14%
Pellet burner	central		76%	64%	47%	41%	62%	33%	0%	19%
Pellet burner	decentral		9%	21%	10%	16%	28%	16%	4%	16%
Combined heat and power	central		10%	10%	18%	18%	0%	18%	25%	23%
Combined heat and power	decentral		1%	1%	11%	11%	10%	11%	2%	11%
Solarthermal for warmwater	decentral		0%	0%	0%	0%	0%	0%	0%	0%
Solarthermal with storage for warmwater and heating	decentral		0%	0%	0%	0%	0%	0%	3%	0%
Geothermal heat	decentral		0%	0%	0%	0%	0%	0%	8%	0%
District heat	existing		0%	0%	0%	0%	0%	9%	0%	0%
<b>Sum</b>			<b>100%</b>	<b>100%</b>	<b>100%</b>	<b>100%</b>	<b>100%</b>	<b>100%</b>	<b>100%</b>	<b>100%</b>
Combined heat and power	central		46%	46%	36%	36%	0%	36%	51%	46%
Combined heat and power	decentral		5%	5%	22%	22%	21%	22%	3%	22%
Photovoltaic	decentral		49%	49%	41%	41%	44%	41%	45%	31%
Elektricity	existing		0%	0%	1%	2%	35%	2%	1%	1%
<b>Sum</b>			<b>100%</b>	<b>100%</b>	<b>100%</b>	<b>100%</b>	<b>100%</b>	<b>100%</b>	<b>100%</b>	<b>100%</b>
Geothermal cooling	decentral		0%	0%	100%	0%	0%	0%	0%	0%
Air conditioner	decentral		0%	0%	0%	100%	100%	100%	100%	100%
<b>Sum</b>			<b>0%</b>	<b>0%</b>	<b>100%</b>	<b>100%</b>	<b>100%</b>	<b>100%</b>	<b>100%</b>	<b>100%</b>
<b>Technologies test area Vienna</b>		<b>Scenario</b>	<b>0-0 2015</b>	<b>0-1-0 2015</b>	<b>0-0 2030</b>	<b>0-1-0 2030</b>	<b>0-1-3 2030</b>	<b>0-1-4 2030</b>	<b>0-1-5 2030</b>	<b>0-1-6 2030</b>
Gas burner	central		80%	0%	55%	57%	0%	7%	0%	81%
Gas burner	decentral		0%	0%	0%	0%	0%	1%	0%	0%
Pellet burner	central		0%	57%	0%	0%	76%	0%	57%	0%
Pellet burner	decentral		0%	0%	0%	0%	24%	0%	0%	0%
Combined heat and power	central		5%	19%	20%	19%	0%	15%	19%	5%
Combined heat and power	decentral		13%	24%	22%	24%	0%	25%	24%	14%
Solarthermal for warmwater	decentral		0%	0%	0%	0%	0%	0%	0%	0%
Solarthermal with storage for warmwater and heating	decentral		0%	0%	0%	0%	0%	0%	0%	0%
Geothermal heat	decentral		2%	1%	3%	1%	1%	0%	1%	0%
District heat	existing		0%	0%	0%	0%	0%	52%	0%	0%
<b>Sum</b>			<b>100%</b>	<b>100%</b>	<b>100%</b>	<b>100%</b>	<b>100%</b>	<b>100%</b>	<b>100%</b>	<b>100%</b>
Combined heat and power	central		28%	44%	48%	44%	0%	35%	44%	25%
Combined heat and power	decentral		72%	56%	52%	56%	0%	59%	56%	75%
Photovoltaic	decentral		0%	0%	0%	0%	53%	6%	0%	0%
Elektricity	existing		0%	0%	0%	0%	47%	0%	0%	0%
<b>Sum</b>			<b>100%</b>	<b>100%</b>	<b>100%</b>	<b>100%</b>	<b>100%</b>	<b>100%</b>	<b>100%</b>	<b>100%</b>
Geothermal cooling	decentral		100%	17%	100%	17%	17%	12%	17%	0%
Air conditioner	decentral		0%	83%	0%	83%	83%	88%	83%	100%
<b>Sum</b>			<b>100%</b>	<b>100%</b>	<b>100%</b>	<b>100%</b>	<b>100%</b>	<b>100%</b>	<b>100%</b>	<b>100%</b>

Tab. 2: Energy technology supply of scenario results in shares of specific technology.

## 4.2 Optimal energy system (other scenarios 0-1-0 to 0-1-6)

In scenario 0-1-0 the central supply of heat is limited to more reasonable parts of the city quarter. In the test area in Graz 57% (2015) of the total heat demand could so be provided from wood pellets. Natural gas and biogas burned in gas burners and combined heat and power plants is 15% (2015, with a share of 58% biogas) and 43% (2030, with a share of 29% biogas).

In the test area in Vienna natural gas use drops to 42% of the total heat demand in 2015 and increases to 99% in 2030. In 2015, 57% of the heat demand are covered with wood pellets. In both scenarios, the 2015 and the 2030 scenario, 1% of the heat comes from geothermal heat and 17% of the cooling demand from geothermal energy (including electricity demand from net). 83% of the cooling demand are covered with air conditioners.

When natural gas costs rise (from 53 Euro to 80 Euro/MWh) or no natural gas is available in the test area in Graz, 90% of heat is generated from wood pellets and 10% from biogas. Cooling energy would be provided by 100% from geothermal plants. Photovoltaic potential would increase to 89%, covering 44% of the total demand. The use of the existing electricity net would increase to 35% because there are less combined heat and power plants.

When natural gas costs rise in the test area in Vienna (from 49 Euro to 80 Euro/MWh), most of the heat would be generated from wood pellets (99%) and 1% from geothermal plants. Cooling energy would be provided by 83% air conditioning and 17% from geothermal plants. In the Viennese case, photovoltaic covers 53% of the electricity demand. 47% are covered with electricity from existing net.

A reduction of the costs of the existing district heat (91 to 45 Euro/MWh in Graz and 80 to 50 Euro/MWh in Vienna) would make it feasible in allowed sub-quarters of the test areas (scenario 0-1-4). In the test area in Graz 9% and in Vienna 52% of the heat could so be provided from the existing district heat, and most of the further demands by pellets (48% Graz), natural gas (48% Vienna) and biogas (just Graz, 29% of total gas demand).

Scenario 0-1-5: When pellets costs rise from 47 to 55 Euro/MWh in the test area in Graz the heat demand is mainly covered with 85% gas (containing 19% biogas), 4% wood pellets (some sub-quarters need decentral burning of wood pellets because energy demand density is too low for grid-based alternative). Geothermal energy generates 8% and solar thermal collectors with storages 3% of the heat demand.

When pellets costs drop from 47 to 45 Euro in Vienna 57% of the heat is generated from wood

pellets, 42% from natural gas and 1% from geothermal energy.

## 5 DISCUSSION

### 5.1 Electricity and heat

In the test area in Graz in most of the scenarios energy demand is mainly covered with biomass because availability of gas and district heat infrastructure is limited and new developments are cost intensive.

The test area in Vienna has a well-developed gas and district heat infrastructure. The availability of local resources is limited and low natural gas prices and electricity can be flexibly provided from central and/or decentral combined heat and power units. Bio-resources become part of the optimal energy system when the natural gas price rises. For Graz this also includes local use of biomass for biogas fermentation.

Geothermal energy is part of the energy system in the test area in Vienna, whereas in the test area in Graz this is just the case when availability of biomass is limited. When geothermal installations can be used longer than the expected minimum lifetime or pellets are not allowed due to particulate matter (PM) limits, installations could also become feasible in Graz. Restrictions in scenarios 0-1-0 to 0-1-6 were made according to local energy suppliers and their scope for development regarding the gas and district heating grid. Together with the restrictions of geothermal heat, this shall test two more practical limitations in the framework.

### 5.2 Cooling

In many scenarios in the test area in Vienna geothermal energy would be a feasible form of energy supply because it can also provide cooling energy in the summer. The comparable little energy demand for cooling in the summer could easily be covered with geothermal energy but especially in Graz due to the low building density a provision of cooling energy over distances is economically not feasible. Realistic chances for installing geothermal energy is given mainly in new building lots.

### 5.3 Bio-resources

A trend reversal to the current low natural gas price seems to be a realistic future scenario. So the chance to economically use biogas in the energy network of the case study area in Graz could rise in the future. The case study area in Vienna is already too densely developed to locate adequate biomass resources which are still free for energy use.

## 6 CONCLUSIONS

Low natural gas prices underline the dictate that as long as the market is spoiled with cheap fossil fuels this acts as a barrier to change to

renewables on a large scale. In their heat supply big Austrian agglomerations are often dependent on gas or coal. Another cost factor is that natural gas can easily be transformed to heat and electricity and existing infrastructure is already there and needs comparably simple fireplaces. Notwithstanding this, local resources (photovoltaic, solar thermal and in Graz biomass) and regional resources (wood pellets) are already financially feasible. Furthermore, the scenarios in the test area in Graz show that a lack of gas and district heat infrastructure development makes decentral and biomass-based solutions more feasible. In the test area in Vienna the lower energy demand of new developments in former railway areas shows high potential to use geothermal energy. Already well-developed gas and district heat infrastructure in Vienna makes fossil fuels financially more attractive there.

## 7 SUMMARY

This paper discusses optimal energy technology systems in spatial energy planning in two Austrian city quarters. It shows how individual urban developments, economic conditions and possible contextual changes influence the selection of optimal energy networks in cities.

## 8 ACKNOWLEDGMENTS

The authors want to thank the BMVIT (Bundesministerium für Verkehr, Innovation und Technologie / Austrian Ministry for Transport, Innovation and Technology) for funding the research throughout the programme Stadt der Zukunft / City of Tomorrow.

The case studies shown in this paper represent one module out of the research project "ERP\_hoch3" (see <http://info.tuwien.ac.at/erphoc/h3/>), which also deals with two other spatial

scopes: The development alongside railway nodes and the regional potentials of renewable energy production.

## 9 REFERENCES

Journal papers:

1. Stoeglehner G., Niemetz N., Kettl K.-H., Spatial dimensions of sustainable energy systems: new visions for integrated spatial and energy planning, *Energy, Sustainability and Society*, 1:2, 2012. p. 1-9.
2. de Jong, M., Joss, S., Schraven, D., Zhan, C., Weijnen, M., Sustainable-smart-resilient-low carbon-eco-knowledge cities; making sense of a multitude of concepts promoting sustainable urbanization, *Journal of Cleaner Production*, Volume 109, 2015. p. 25-38.
3. Maier S., Narodoslowsky M., *Optimal Renewable Energy Systems for Smart Cities*, Computer Aided Chemical Engineering, Elsevier, ISSN 1570-7946, ISBN 9780444634344, 2014. 33, p. 1849-1854.

Reports:

4. UN (2008) United Nations Expert Group meeting on population distribution, urbanization, internal migration and development, Population Division, Department of Economic and Social Affairs, UN Secretariat, 1-34, [http://www.un.org/en/development/desa/population/events/pdf/expert/13/P01\\_UNPopDiv.pdf](http://www.un.org/en/development/desa/population/events/pdf/expert/13/P01_UNPopDiv.pdf)
5. Friedler, F., Varga, J.B., Fan, L.T., Decision-mapping: a tool for consistent and complete decisions in process synthesis. *Chemical Engineering Science*, 1995. Vol. 50, p. 1755-17682.

Tools:

6. PNS Studio, Software Version 3.0.4, 2011.

Zurich, June 15-17 2016

Sustainable Built Environment (SBE) Regional Conference

## Expanding Boundaries: Systems Thinking for the Built Environment



### ENERGY AND THE CITY: INVESTIGATING SPATIAL AND ARCHITECTURAL CONSEQUENCES OF A SHIFT IN ENERGY SYSTEMS ON DISTRICT LEVEL IN A SUMMER SCHOOL

A. Willmann<sup>1\*</sup>, S. Cisar<sup>2</sup>, Z. Nagy<sup>1</sup>, A. Schlueter<sup>1</sup>

<sup>1</sup> Architecture and Building Systems, Institute of Technology in Architecture, ETH Zurich, John-von-Neumann-Weg 9, CH-8093 Zurich, Switzerland

<sup>2</sup> Sustainable Construction, Institute of Construction and Infrastructure Management, ETH Zurich, Stefano-Franscini-Platz 5, CH-8093 Zurich, Switzerland

\*Corresponding author; e-mail: anja.willmann@arch.ethz.ch

#### Abstract

This paper presents the approach, methods and results of an international summer school, InduCity, conducted at the ETH Zurich in collaboration between the Chairs of Architecture and Building Systems and Architecture and Urban Design. The objective of the summer school was to study potential interactions between future renewable energy systems and urban design and development. While transforming a former industrial site into a sustainable mixed-use urban neighbourhood, participants investigated the reciprocal relationship between modes of energy demand, supply and storage, and the built morphology and qualities of public space. Contrasting the common process of developing the energy concept on district level after designing the urban form, we established two different holistic transformation narratives, each equipped with a focused energy strategy to imply an energy driven design. For narrative one an introverted urban form was combined with a decentralized energy network whereas for narrative two a more flexible and open urban structure was combined with a local and autarkic energy supply. After analytical work, students engaged in design experiments based on energy harvesting strategies and established new programs and types of public space linked to different energy generation and storage technologies. The strategies operated on multiple levels: from urban growth scenarios driven by energy policies to urban morphologies defined by energy balance and building typologies developed according to storage technologies, to the design of public spaces inspired by energy storage. The design process and its results reveal conspicuous impacts of the energy supply strategies on the building, neighbourhood and district scales of urban development. The applied methodology proved very suitable for the prevalent teaching task of designing sustainable city quarters, and can be applied easily to other sites and tasks.

#### Keywords:

Energy; Urban Design; Sustainable City Quarter; Renewable Energy; Architectural Teaching

#### 1 INTRODUCTION

To meet the goals and challenges of global reduction of the carbon footprint [1], Switzerland focuses on the environmental performance of cities. Initiated in 2008, the 2000-Watt/-1t CO<sub>2</sub> society calls for a reduction of ¼ of every inhabitant's footprint by 2050. On district scale, the so-called "2000-Watt-Areale", a set of

punctual projects all over Switzerland, have been established and analysed over the last years [2].

Research on energy efficient communities mainly concentrates on urban economics, density, transportation and the building envelope [3]. However, the question of the relationship between city texture and energy consumption has not been answered sufficiently yet [4]. Ratti proved that the overall variation of energy

consumption on urban geometry is very little. The ratio of passive to non-passive zones, the surface to volume ratio and the glazing ratio with orientation have been analysed and it was shown that the relevant design indicator for energy consumption on an urban level is passive zoning [4].

The InduCity research project, carried out by the authors, has proven that the type and mixture of functions has a significant impact on primary energy (PEN) and carbon emissions (CO<sub>2</sub>) on district scale. Furthermore, for the case study under research, infrastructural upgrades on district energy supply systems provided a higher impact than building retrofit [5], [6]. Energy efficiency measures and the increase of share of renewable energy sources are prior challenges for urban planning in developed countries [3]. Hence, due to its type-specific energy consumption energy infrastructure as well as building use will become relevant parameters for urban and architectural design.

In contemporary architectural education environmental sustainability is often considered as an addition to the architectural design rather than an integrated prerequisite [7]. This is reflected in the current educational approach of design studios: Environmental design is mostly taught in parallel course work instead of being integrated in the design task and the design process. The InduCity summer school aimed to alleviate this shortcoming by integrating energy as a design parameter within a design studio set up (Figure 1).

This paper details the curriculum of the summer school in section 2.1, the essential data background in section 2.2, the scenario narratives in section 2.3 and results on the task and the teaching approach in section 3. It further discusses lessons learned and provides an outline on future courses applying the explored teaching methodology in section 5.

## 2 INDUCITY SUMMER SCHOOL

### 2.1 Curriculum

#### Organisation

The InduCity summer school took place from 17<sup>th</sup> to 26<sup>th</sup> of June in 2013 at ETH Zurich. It was a collaboration between the Chair of Architecture and Building Systems - Prof. Arno Schlueter (A/S formerly SuAT) and the Chair of Architecture and Urban Design – Prof. Kees Christiaanse. 16 students mainly from ETH Zürich and EPFL participated, ranging from bachelor level to doctoral students including exchange students from UPC Barcelona, NUS Singapore and ETSA Valencia.

#### Scope

The InduCity summer school aimed to explore the impact of energy as a design parameter within the disciplines of urban design and architecture.

#### Structure

Fig 2 displays the two-fold teaching structure analytical and narrative to introduce energy as a design parameter. The site was analysed regarding topology, transport infrastructure, public space, morphology and program, actor networks, regulations and projects, energetic synergy potential and renewable energy sources. The urban design development was based on combining the themes in two predetermined narratives and focusing on energy.

The twofold method of analysis and narrative as an iterative design development was crucial for students to learn about the site in question, tools for urban design and how to implement designs based on quantitative and qualitative aspects of energy.

Continuous student output was key for reflection and integration of analysed themes and designing narratives (Figure 2). Critical input and feedback by means of student presentations for selected guests from different fields i.e. urban design, architecture and energy sciences stimulated continuous design development.

#### Sequence

An introduction with lectures by both hosting chairs was followed by a site visit of the Siemens Areal in Zug, Switzerland. The students were tasked to explore and document the site and its buildings in order to get an understanding of the context of the summer school topic. Based on the site visit and further research students would then analyse in groups of two the different themes and present their findings. Additionally, selected speakers were invited to introduce the research project InduCity and its findings, energy technologies and their applications, geo-information systems and how to represent energy. The different analytical themes and the students were then combined into two pre-defined narratives, entitled 'Campus' and 'Urban Condenser' (UC) (Figure 2). The design development entailed representing design interventions in plans and models, mapping energy potential and its relationship to the design proposal which was presented to selected guests in the middle of the summer school and at the end of the summer school. The interim review helped students to clarify and how to further develop the proposals regarding urban design and energy. Lectures and an open discussion with guests and experts were critical for the design development. A final presentation would conclude the summer school and offer the possibility to reflect on the design proposals.





Fig. 1: Studio work mode.

## 2.2 Data Background

### InduCity research project

Based on the results of the research project InduCity, students were provided with data of the status quo and data for future scenario calculation. The data regarding status quo contained information on buildings, infrastructure, industrial processes, building uses and mobility patterns to set a base line energy consumption data [6]. Examples are shown in Figure 3 and 4. In addition, a carbon footprint methodology had been developed to assess the scenarios within the 2000-Watt/ 1t CO<sub>2</sub> society framework. [5]

Established on a cross-sectional (industry, buildings and transportation) and multi-dimensional (during construction and operation)



Fig. 3: Masterplan Status quo [8].

## 2.3 Narratives

Key aspect of the iterative design development was the transformation of analytical themes into two synergetic narratives. The narratives serve as framework each with a specific scenario for future urban development scenario and energy supply. The aim was to explore how energy would influence urban form and vice-versa.

## From Analysis to Narrative

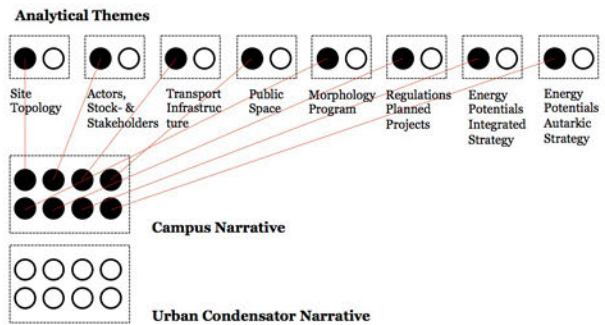

Fig. 2: Sequenced group work approach [8].

comparison of the resulting environmental impact [6] of four possible scenarios at the site derived from the InduCity research project, we provided the two scenario narratives with the lowest overall carbon footprint for the summer school. Scenario construction during the research project was carried out according to [9]. Additionally, the data of the status quo was provided [5]. Regarding design parameters, i.e. density, program etc. and energy related decisions, both narratives were opened up to allow the students to own the scenarios by developing a group-specific scenario definition. For this reason and as the research project InduCity was lacking an urban design analysis, students had to carry out this analysis first to specify their approach.



Fig. 4: Domestic hot water demand of the district by building [8].

Students were tasked to implement a design proposal for each of the two narratives. The 'Campus' narrative assumed an urban form with a clear boundary towards the surrounding context. The programming emphasised the function of centrality. It focused on offices, research and education, complemented with high-end housing and maintaining some existing industrial program. The scenario assumed a few

large-scale actors and underscored the centrality by developing the site vertically to increase densification. The centralised urban form would be counteracted by a decentralised energy strategy connecting to and exchanging with the urban context and neighbouring buildings to explore versatile strategies of renewable energy supply.

The 'Urban Condenser' narrative assumed an urban form with a less strict boundary and a stronger mixing with the urban context. The programming emphasised complementing the urban context. It focused on multi-generational housing. Utilising the large-scale structures of the former industrial program as mixed-use and multi-purpose open structures allows for small and fragile actors to occupy and develop flexible programming. To explore the possibilities arising from an energetic alliance based on a manifold community, this narrative was tasked with a centralised energy strategy.

Summarizing, the approach consisted of representing the narrative's potential, formulating a vision and a strategy for both the urban form and energy. The representation of the application would in turn display the spatial consequence of energy and the city.

### 3 SUMMER SCHOOL RESULTS

The students working on the 'Campus' narrative informed their campus vision with programmatic synergy of the two main identified actors, a university and the existing industrial corporation (Figure 5). They also explored recreational potential for its program of education and industry in the adjacent urban context and nature identifying many attractive opportunities. It included existing sports facilities and infrastructure as well as nature recreation areas nearby the lake and forests. The renewable potential analysis resulted in an overlap of local resources with recreational areas. The urban strategy was to connect the recreational areas and renewable energy resources with the



Fig. 5: Campus: Masterplan including tree [10].

'Campus' through a cohesive element, a green infrastructure. A continuous tree structure inside and outside the 'Campus' serves as a spatial entity, a recreational space that can be harvested for renewable resources as shown in Figure 6.

Students working on the 'Urban Condenser' narrative proposed a mixed-use city quarter focusing on housing and places for exchange. The aim was to maintain most of the existing structures but change their programming. An energy network initially balances the diverse demand and supply. The urban strategy is based on a policy tool to manage the urban development potential on site according to its energy balance. It mandates small-scale energy infrastructure like production, storage and increased efficiency to potentially impact and benefit further planning. It combines measures for energy and buildings, from existing structures to future transformations for an incremental development complementing its urban context. Details on the policy framework can be found in Figure 7 and 8. Future transformation mandated by the development policy would incrementally increase housing. New buildings are self-sufficient and thus support their own demand. If necessary, they complement remaining existing and reused buildings.

The application of the summer school structure outlined in 2.1 allowed an iterative design development by students with a sufficient degree of flexibility. The students were able to explore on one hand how the availability of resources and energy supply systems can determine urban growth and urban form as in the 'Urban Condenser' narrative. On the other hand, designing urban space for trees as a cohesive element emphasizes the significance of renewable energy sources within the city. By integrating these elements into the public realm, buildings and streets literally have to make space for energy sources. Conclusively, both results can be synthesized in spatial responses individual to the narratives.

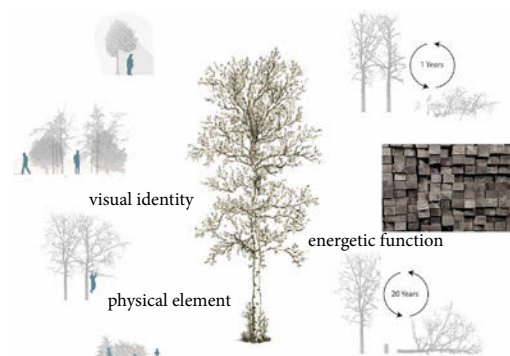

Fig. 6: Campus: Trees as cohesive element [10].

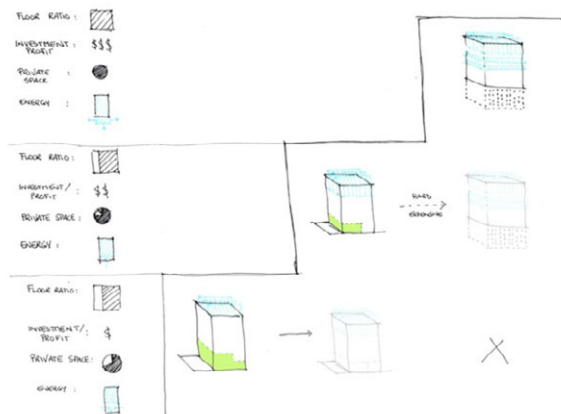

Fig. 7: UC: Set of rules for development [11].

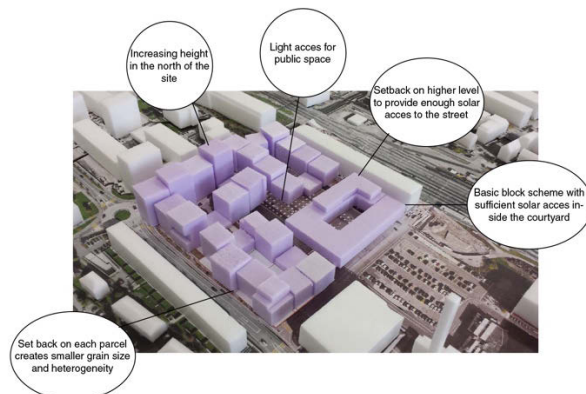

Fig. 8: Spatial development according to rules [12].

#### 4 SUMMARY

This paper summarizes the summer school InduCity conducted in 2013 at the ETH Zürich focusing on combining energy as an urban design parameter and utilising real energy data and models from a parallel research project. The participating students engaged the selected site in a design studio environment. They analysed key urban design and energy potentials to develop two future proposals. The two proposals are based on two narratives each with a specific framework on programming, energy systems and urban form. The student's analysis was supposed to inform their iterative design development by combining urban design and energy. The results found two distinct translations of design including their spatial consequences. The 'Campus' featured a 'green infrastructure' combining recreational and renewable energy infrastructure and potentials. The 'Urban Condenser' featured a 'policy' mandating an incremental development including the possible reusing of existing structures and new energy self-sufficient housing. The InduCity summer school therefore successfully displayed the relationship and spatial consequence of energy and urban design through means of design and specific design proposals.

#### 5 DISCUSSION AND CONCLUSION

The InduCity summer school has explored the impact of renewable energy systems on urban form. In both scenarios new planning tools were developed. Within the 'Campus' narrative it mainly impacts the public realm, in the 'Urban Condenser' narrative the energy balance will determine growth and density of the built environment.

The key limitation to the level of investigation was the duration of the summer school being only ten days, however promising results were achieved. This could be expanded to greater detail in a

setting such as a full-semester course. In addition, any quantification of renewable energy potentials, harvesting and storage was based on simplified calculations. Assessment to the 2000-Watt-society as carried out within the research project was not possible. Students would need to be provided a better calculation tool that can iteratively calculate the current energy status during the design process such as provided by the CEA tool. [13]

The method of the summer school was limited to renewable energy, urban design and schematic architectural design. According to the BESQoL-method [14], this approach could benefit from being broadened by varying factors as movement, economics and human capital and quality of life to gain a more holistic view on the site, especially its shortcomings and potentials to not only improve PEN and CO<sub>2</sub> emissions but quality of life by urban redesign.

#### 6 ACKNOWLEDGEMENTS

The continuing support in preparation and implementation of the summer school by Daniel Kiss, Chair of Architecture and Urban Design – Prof. Kees Christiaanse is gratefully acknowledged. Furthermore, the contributions by Dr. Michael Stauffacher, Dr. Corinne Moser, Fabienne Hoelzel, Prof. Dr. Stefan Kurath, Martin Haas, Adrian Altenburger, Markus Schaefer, Dr. Peter Kiefer and Stefano Grassi are gratefully acknowledged. Participating students in the InduCity summer school were: Albert Achammer, Anne Charlotte Astrup Chauvaux, Daniela Bolli, Juliana Felkner, Sara Vima Grau, Niklaus Haller, Arpad Hetey, Maryam Jafarbegloo, Nan Jiang, Mattias Frederik Josefsson, Orkun Kasap, Li Fang Lee, Francisca Molina, Nicolas Pierret, Michael Andreas Reisinger and Vera Schmidt. This summer school was supported by Climate KIC.

## 7 REFERENCES

1. IPCC, 2014: Climate Change 2014: Synthesis Report. Contribution of Working Groups I, II and III to the Fifth Assessment Report of the Intergovernmental Panel on Climate Change [Core Writing Team, R.K. Pachauri and L.A. Meyer (eds.)]. IPCC, Geneva, Switzerland, 151 pp.
2. Kellenberger, D., M. Menard, S. Schneider, M. Org, K. Victor and S. Lenel, Arealentwicklung für die 2000-Watt Gesellschaft: Leitfaden und Fallbeispiele, Bern, 2012.
3. Madlener, R., and Y. Sunak, Impacts of urbanization on urban structures and energy demand: What can we learn from urban energy planning and urbanization management? Sustainable Cities and Society 2011. 1: p.45-53.
4. Ratti, C., N. Baker, and K. Steemers, Energy consumption and urban texture. Energy and buildings 2005. 37: p. 762-776.
5. Fonseca, J. A. and A. Schlueter, Method and data analysis for assessment of local energy potentials for urban transformation: a case study of a mixed use city quarter, in CISBAT 2013, 2013, pp. 649-654.
6. Fonseca, J. A., A. Willmann, C. Moser, M. Stauffacher and A. Schlueter, Assessing the environmental impact of future urban developments at neighbourhood scale, in CISBAT 2015, 2015, pp. 457-462.
7. Altomonte, S., Environmental education for sustainable architecture. Review of European Studies 2009. 1: p. 12-21
8. Willmann, A. S. Cisar, D. Kiss, K. Christiaanse and A. Schlueter, Reader. Energy and the city. InduCity summer school. ETH Zurich. 2013.
9. Gausemeier, J., A. Fink and O. Schlake, Scenario management. An approach to develop future potentials. Technolog. Forecast. Soc. Change 1998, 59: p. 111-130.
10. Achammer, A., A. Astrup-Chauvaux, J. Felkner A. Hetey, M. F. Jofesson, F. Molina, V. Schmidt and S. Grau Vima, Indu-Lab Zug. Final presentation: InduCity summer school, ETH Zurich. 2013
11. Willmann, A. S. Cisar, D. Kiss and A. Schlueter, Report: Energy and the city. InduCity summer school. ETH Zurich. 2016.
12. Fang Lee, L., N. Pierret, M. A. Reisinger, D. Bolli, M. Jafarbegloo, O. Kasap, N. Haller and N. Jiang, Urban Condenser. Final presentation: InduCity summer school, ETH Zurich. 2013
13. Fonseca, J. A., D. Thomas, A. Willmann, A. Elesawy and A. Schlueter, The city energy analyst toolbox part I: Demand and LCA modules, in SBE16, 2016 (forthcoming)
14. Sassi, P., Chapter: Built environment sustainability and quality of life (BESQoL) assessment methodology. In: Engaging stakeholders in education for sustainable development at university level. 2016, Springer Verlag, Switzerland, p. 21-31.

Zurich, June 15-17 2016

Sustainable Built Environment (SBE) Regional Conference

## Expanding Boundaries: Systems Thinking for the Built Environment



### OPTIMAL ENERGY SYSTEM TRANSFORMATION OF A NEIGHBOURHOOD

R. Wu<sup>1\*</sup>, G. Mavromatidis<sup>1,2</sup>, K. Orehounig<sup>1,2</sup>, J. Carmeliet<sup>1,3</sup>

<sup>1</sup> Chair of Building Physics, ETH Zürich, Stefano-Franscini-Platz 5, 8093 Zürich, Switzerland

<sup>2</sup> Laboratory for Urban Energy Systems, Swiss Federal Laboratories for Materials Science and Technology, Überlandstrasse 129, 8600 Dübendorf, Switzerland

<sup>3</sup> Laboratory for Multiscale Studies in Building Physics, Swiss Federal Laboratories for Materials Science and Technology, Überlandstrasse 129, 8600 Dübendorf, Switzerland

\*Corresponding author; e-mail: wur@student.ethz.ch

#### Abstract

This paper presents a methodology for optimising the energy system transformation of a neighbourhood that can simultaneously assess energy supply and retrofitting measures. The method combines the assessment of retrofitting measures using dynamical simulation tools and multi-criteria decision making based on the energy hub concept. Considered objectives include minimisation of life cycle costs, CO<sub>2</sub> emissions, primary energy use and a weighted environmental impact measure defined according to the current Swiss environmental policy.

In this study, typical buildings of various ages, sizes and retrofit states are considered, which allows both individual building owners and neighbourhood or town policy makers to find a retrofit strategy tailored to their individual or collective criteria and goals.

The approach is then applied to a number of typical residential buildings in the Swiss village of Zerne, which has a diverse residential building stock in terms of age, size, and retrofit states amongst other constraints.

The performance of various retrofitting options of the building envelope and system changes including biomass heating systems, heat pumps, photovoltaic, and solar thermal panels are assessed. Simulation results show a diverse choice, mainly depending on building age and optimisation criteria. Individual strategies for different age groups are therefore proposed to reach the goals of the Swiss energy strategy 2050 and a 2000 Watt society.

#### Keywords:

Retrofit and Building System Optimisation; Energy Hub; CO<sub>2</sub> Reduction; Neighbourhood

### 1 INTRODUCTION

When facing future energy and environmental challenges, buildings have a large impact as major energy consumers with long life cycles [1].

With the vast number of possible solutions, a systematic approach is needed to determine economic and environmental viabilities for each transformation strategy.

This paper presents a methodology for optimising building energy system transformations that can assess energy supply and retrofitting measures simultaneously, combining the assessment of retrofitting measures using dynamical simulation

tools and multi-criteria decision making based on the energy hub concept.

Similar studies focusing on multi-objective optimisation of energy demand and supply measures were conducted by Bayraktar et. al [2]. Tadeu et. al. [3] and Schwartz et. al [4] add a life cycle perspective while focusing on retrofit measures. Within the present contribution, considered objectives include minimisation of costs, CO<sub>2</sub> emissions, primary energy (PE) use and a weighted environmental impact measure defined according to the current Swiss environmental policy (UBP13 [5]).

The approach is applied to typical residential buildings in the Swiss village of Zerne, which is currently running a pilot project to reduce its use of fossil fuels and environmental impact.

## 2 METHODS

First, the energy demands of each building are simulated for various retrofit scenarios. The resulting demand profiles serve as inputs for an energy hub optimisation, which optimises energy supply systems for every building and retrofit scenario.

### 2.1 Building energy demand and supply simulations

Using geometrical data and information about the location, age and construction type, buildings are modelled and simulated in EnergyPlus [6]. Domestic hot water (DHW) demands are simulated with DHWcalc [7].

8760 hourly values for heat, DHW and electricity demands are simulated for every building and retrofit scenario, and serve as inputs for the energy hub optimisation. Furthermore, the irradiation on south facing roof areas is determined to get the available solar energy.

### 2.2 Energy hub optimisation

Energy supply systems to provide electricity, space heating and DHW are optimised using an energy hub, formulated according to the method of Mavromatidis et al. [8]. The following types of constraints are implemented using AIMMS [9]:

- Energy balances for heat, electricity and DHW storage
- Non-violation constraints on the maximum power of each conversion system, used to determine its capacity
- Constraints imposing fixed costs and minimum plant capacities if a technology is chosen
- Maximum charge and discharge rates of the storage tank
- A constraint preventing simultaneous grid electricity consumption and feed in

This study's energy hub is shown in Fig. 1, with inputs  $I$  and outputs  $L$ . Typical residential energy conversion and storage systems are considered: Air (ASHP) and ground source heat pumps (GSHP), biomass boilers, photovoltaic (PV) and solar thermal (ST) panels. A DHW tank is assumed to be present in all buildings, sized according to the number of inhabitants.

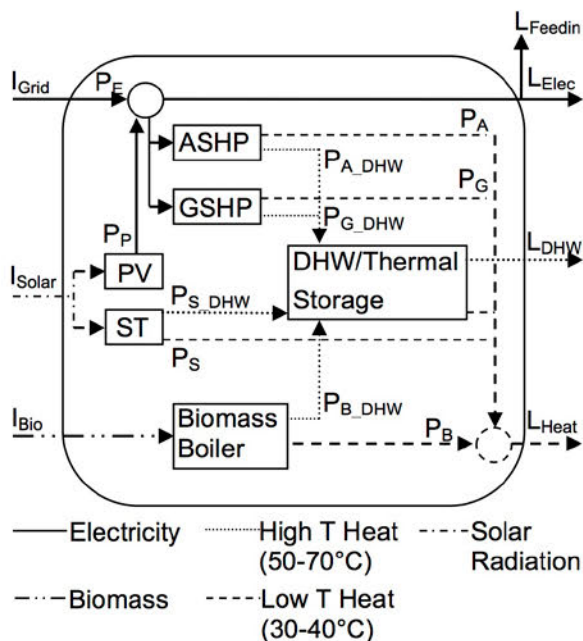

Fig. 1: Energy hub layout.

Two types of objective functions are considered, annualised costs and life cycle environmental impacts.

Each energy conversion technology  $T$  contributes to the costs with its investment cost, split into fixed cost ( $f_c$ ) and subsidies ( $f_s$ ), and capacity ( $cap$ ) dependent linear costs ( $l_c$ ) and subsidies ( $l_s$ ). The binary decision variables  $y_T$  determine whether a technology is installed. The input energy carriers ( $i$ ) are multiplied with their costs ( $c$ ), the feedin electricity ( $l_{feedin}$ ) with the feedin tariff ( $c_{feedin}$ ) and summed over time. The resulting objective function for costs  $o_1$  is:

$$o_1 = \sum_T ([f_{c_T} - f_{s_T}] * y_T + [l_{c_T} - l_{s_T}] * cap_T) / a_T + \sum_t (i * c - l_{feedin} * c_{feedin}) + c_R / a_R \quad (1)$$

$$i = [i_{Grid} \quad i_{Bio}], \quad c = [c_{Grid} \quad c_{Bio}]^T \quad (2)$$

Investment and retrofit ( $c_R$ ) costs are annualised using the equivalent annual cost method [10], considering their lifetimes  $\tau$  and a yearly interest rate  $r$ .

The nonfinancial objective functions can be expressed as the products of all conversion outputs ( $p$ , indicated as  $P_i$  in Fig. 1) with their impact factors  $f_E$  summed over time, and the impact of all retrofit materials  $R$  with their masses ( $m_R$ ), impact factors ( $f_R$ ) and lifetimes ( $\tau_R$ ):

$$o_2 = \sum_t (p * f_E) + \sum_R (m_R * f_R) / \tau_R \quad (3)$$

## 3 THE CASE STUDY

The presented method is applied to residential buildings in Zerne, for which building database in terms of geometry, energy use and retrofit state was compiled in 2012. 214 residential buildings are categorised in terms of their age,

size and current heating system. 11 typical buildings, ranging from detached (D) to semi-detached (SD) and large multifamily houses (L), built between 1870 and 1999 are selected to represent the different categories.

### 3.1 Modelling input data

Geometrical data comes from the Zernez database and a 1:25000 map [11]. Wall, roof and floor constructions and U-values are taken from an overview of historical constructions [12], whereas internal gains, daily DHW volumes, heating setpoints, lighting and occupancy profiles are calculated using the SIA 2024 standard [13], assuming a floor area distribution of 80% living space, 10% kitchen and 10% bathrooms for all buildings.

In addition to the base case without retrofit, 8 scenarios are analysed. The following envelope components are retrofitted either to the SIA 380/1 [14] limit or target values:

- Roof
- Windows
- Façade (windows and walls)
- Whole building

For buildings built after 1960, the U-Values are adjusted by adding a typical insulation material such as expanded polystyrene on the outside.

An aerogel is applied to older, protected buildings. Air change assumptions are given in Table 2.

Energy demand simulations are based on 2002 weather data from the neighbouring village of Scuol.

For the energy hub optimisation, life cycle costs, CO<sub>2</sub> [15], (nonrenewable) Primary Energy and UBP13 serve as objective functions.

Unsubsidised costs, minimum plant size and system lifetime assumptions are based on commercially available systems in Switzerland. DHW tanks are assumed to have a capacity of 600-1000 l, depending on the number of inhabitants. In Table 3, the assumed energy carrier costs are listed, while Table 1 summarises

the assumed parameters for all energy conversion systems, including the current oil and electric resistance heating systems, which are used as a reference.

Retrofit costs are taken from a Swiss building energy and retrofit analysis tool [16], and discounted over a lifetime of 50 years.

Federal [17] and Cantonal [18] subsidies for retrofit and energy systems are included in the subsidised cost optimisation. All investment costs are annualised using a yearly discount rate of 5%.

Life cycle CO<sub>2</sub>, PE and UBP13 are calculated per unit of final delivered energy. For building retrofit, the CO<sub>2</sub>, PE and UBP13 embedded in the materials are considered [5] and divided by the lifetime of 50 years.

Retrofit State/Age	ACR [1/h]
Base case (<1980)	0.7
Base case (>1980)	0.6
Roof	0.6
Windows	0.6
Façade	0.5
Whole Building (SIA380/1 Limit)	0.4
Whole Building (SIA380/1 Target)	0.3

Table 2: Assumed air change rates (ACR).

	Cost [CHF/kWh]
Electricity	0.2
Electricity (feedin)	-0.15
Wood (logs)	0.075
Wood (pellets)	0.09
Heating Oil	0.1

Table 3: Assumed electricity and fuel costs.

Technology	Fixed Cost [CHF]	Linear Cost [CHF/kW]	Lifetime [years]	Minimum size [kW]	Efficiency / COP
Biomass boiler	32'000	100	20	20	0.7
GSHP	20'000	2'380	20 <sup>1</sup>	5	4, 2.75 <sup>2</sup>
ASHP	18'300	1'020	20	5	3, 2 <sup>2</sup>
ST	4'000	1'000 [CHF/m <sup>2</sup> ]	25	4 [m <sup>2</sup> ]	0.7
PV	900 <sup>3</sup>	400 [CHF/m <sup>2</sup> ]	30	5 [m <sup>2</sup> ]	0.15
Electrical heating	14'600	730	30	-	1
Oil boiler	16'600	460	25	-	0.85

<sup>1</sup> The GSHP borehole, which is assumed to make up 45% of the entire system cost, is discounted over 50 years.

<sup>2</sup> Heat pumps are assumed to have a higher COP for heating than for DHW

<sup>3</sup> For protected buildings, built-in PV modules with fixed costs of 3'000 CHF are considered.

Table 1: Summary of energy conversion parameters.

## 4 RESULTS AND DISCUSSION

### 4.1 Energy demands

Figure 2 shows the simulated heating demands, which are reduced by more than 50% from the base case to maximum retrofit in all buildings.

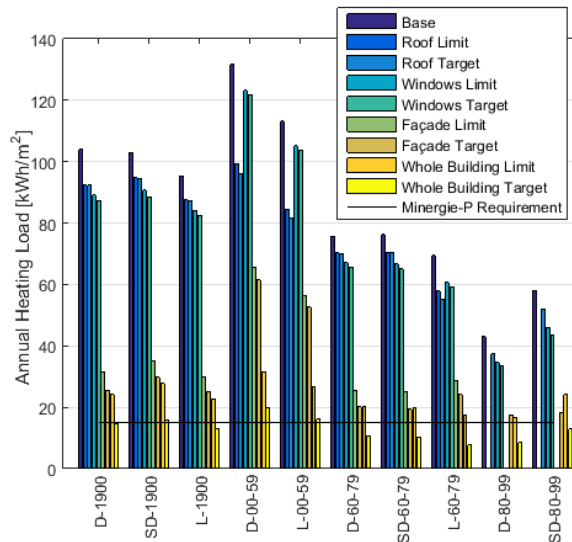

Fig. 2: Simulated heating demands of all buildings in all retrofit states.

U-values, and air change rates, which primarily depend on user behaviour and building airtightness, have the largest influence on heating demands. A sensitivity analysis for an old building (D-1900) shows that changing each parameter by 10% leads to a 5% change in heating demand.

The simulated average annual electricity consumption of 34.6 kWh/m<sup>2</sup> is higher than in the survey, but still at the lower bound of SIA 2024.

### 4.2 Costs

Subsequently, the energy demands for all buildings and scenarios are used as inputs for the energy hub calculations. Figure 3 shows optimisation results in terms of average equivalent annual cost breakdowns per age category for the different scenarios, including the original heating system solutions. Costs are divided into operational costs (Energy), costs for building envelope interventions (Retrofit), costs for system interventions (System Investment), and additional total costs if subsidies are not considered (Unsubsidised). Cases “Original Heating System” and “Base” have the same energy demand, but in the Base case, the energy system is optimised.

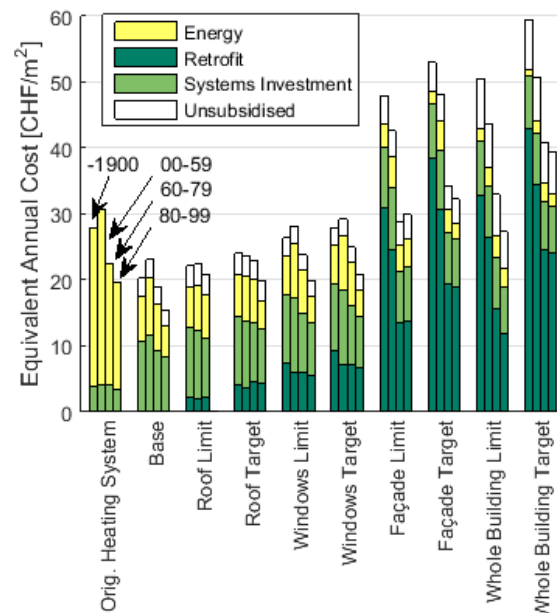

Fig. 3: Age-averaged total costs.

The results suggest that ASHP, PV and no retrofit are the cheapest unsubsidised solution for all buildings. As retrofit, efficient heating systems and PV are all subsidised in Graubünden as of May 2015, the subsidised cost structure is still dominated by the retrofit costs. As subsidies are doubled once the whole building is retrofitted, a whole building limit retrofit becomes cheaper than a façade retrofit to SIA target values.

Retrofitting old, protected buildings with aerogel costs up to 120% more than the current state, where the cost spread between the current configuration and a whole building, SIA limit retrofit decreases to 5-60% for buildings in the 1960-79 category and to 0-30% for buildings built in 1980-99.

### 4.3 Life cycle CO<sub>2</sub>

Figure 4 shows CO<sub>2</sub> optimisation results and the current state per age category. As local wood logs are a limited resource, three scenarios are evaluated:

When minimising CO<sub>2</sub> without biomass restrictions, maximum PV and wood log heating systems are preferred.

If biomass is available as wood pellets, pellet heating systems are combined with PV and – for some buildings – small solar thermal plants.

If biomass is unavailable, GSHP are used in conjunction with PV and in some cases small solar thermal systems.

Total CO<sub>2</sub> emissions are dominated by the energy use, which leads to a decrease in total CO<sub>2</sub> emissions with increasing retrofit. The minimum occurs between façade and whole building retrofit.



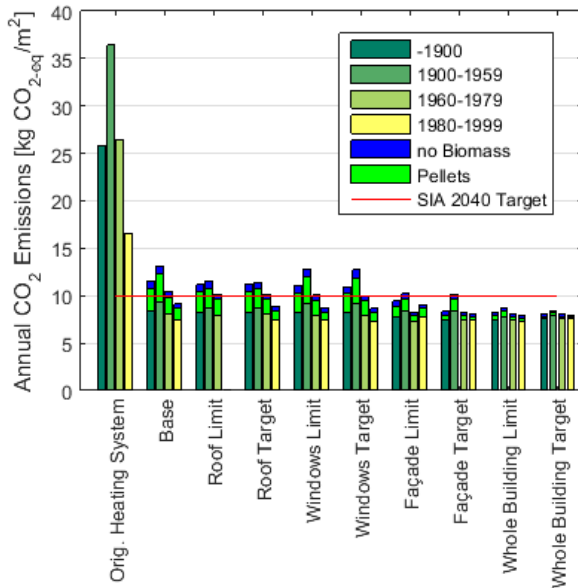

Fig. 4: Age-averaged total CO<sub>2</sub> emissions.

#### 4.4 Primary Energy and UBP13

Nonrenewable PE, as shown in Fig. 5, is minimised with GSHP and maximum PV.

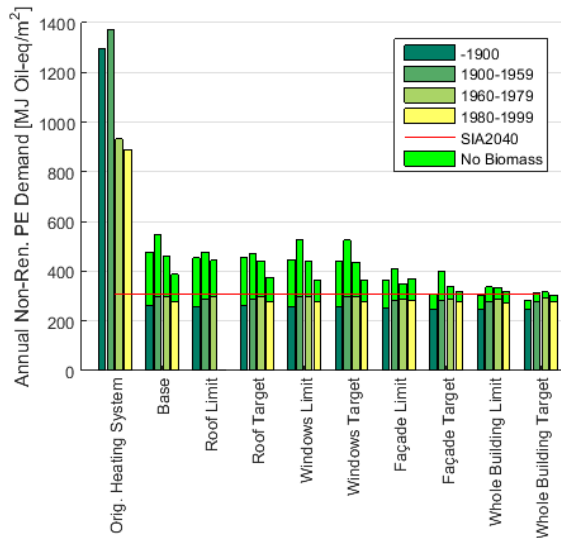

Fig. 5: Nonrenewable PE consumption.

The non-renewable PE and UBP13 optimisations leads to similar energy system choices as in the CO<sub>2</sub> scenarios. Biomass is combined with maximised PV, or GSHP with PV and small solar thermal plants if biomass is not available. Maximum retrofit is preferred for all buildings.

#### 4.5 Summary

An overview of the preferred systems and retrofit states for all objectives is given in Table 4. With the exception of GSHP and ASHP for cost, the technology choice is independent of the building age, size and type.

Objective	Heating	Solar	Retrofit
Cost	A/GSHP	PV	None
CO <sub>2</sub> , UBP13 and non-ren. PE	Biomass (Logs)	PV	Façade/ Whole Building
CO <sub>2</sub> – no Logs	Biomass (Pellets)	PV + ST	Whole Building
CO <sub>2</sub> , UBP13 and non-ren. PE – no Bio	GSHP	PV + ST	Whole Building
PE	GSHP	PV	Whole B.

Table 4: Overview of preferred technologies and retrofit states.

Retrofitting buildings built after 1960 to SIA 380/1 target values would lead to an average cost increase of 20% compared to the current configuration, and would substantially improve the ecological performance, with most buildings complying with the 2000W society goals [19].

Building age was found to have a larger influence than size on all objectives. Due to their increased compactness, larger buildings perform slightly better than single family homes when comparing all objectives per m<sup>2</sup> of inhabited floor area.

## 5 CONCLUSION

This study presents a method to assess and optimise retrofit and energy supply systems simultaneously, which is applied to typical residential buildings in Zerne, Switzerland.

All considered technologies are favoured for at least one objective function, whereby a combination of fully retrofitted building envelope together with a biomass or heat pump based system leads to lowest environmental impact.

However, optimisation results for costs show that retrofitting is an expensive solution, especially for protected buildings. Most cantons subsidise retrofit, although for older buildings, partial retrofitting together with a local biomass based heating system might be a more optimal way to achieve environmental targets. Without retrofit, 2000W targets are not reached for all buildings. However, retrofit typically leads to improved comfort, which is not considered here, and which might bring additional value for the buildings.

To conclude, the present contribution shows that the optimal envelope and system interventions for residential buildings is strongly dependent on the objective, and focusing only on a single parameter might not always lead to the optimal choices.

## 6 ACKNOWLEDGEMENTS

Research presented in this paper is supported by funds from CCEM (IDEAS4cities project), and the Swiss Competence Centre SCCER "Future Energy Efficient Buildings and Districts."

## 7 REFERENCES

1. Levermore, G. J., A review of the IPCC assessment report four, part 1: the IPCC process and greenhouse gas emission trends from buildings worldwide. Building Services Engineering Research and Technology, 2008. 29.4: p. 349-361.
2. Bayraktar, M. et al., The "extended building energy hub": A new method for the simultaneous optimization of energy demand and energy supply in buildings. HVAC&R Research, 2012. 18.1-2: p. 67-87.
3. Tadeu, S., et al., Energy retrofit of historic buildings: Environmental assessment of cost-optimal solutions. Journal of Building Engineering, 2015. 4: p. 167-176.
4. Schwartz, Y. et al., Multi-Objective Genetic Algorithms for the Minimisation of the Life Cycle Carbon Footprint and Life Cycle Cost of the Refurbishment of a Residential Complex's Envelope: A Case Study, in SimAUD. 2015: Washington DC, USA. p. 103-110.
5. Koordinationskonferenz der Bau- und Liegenschaftsorgane der öffentlichen Bauherren, Ökobilanzdaten im Baubereich. 2014, KBOB: Bern.
6. U.S. Department of Energy, Energy Plus Simulation Software V8-3-0. Available at <https://energyplus.net/>, 2015. Accessed 18 March 2015.
7. Jordan, U. and Vajen, K., DHWcalc v.1.10. Available at <http://www.solar.uni-kassel.de>, 2003. Accessed 21 April 2015.
8. Mavromatidis, G. et al., Multi-objective optimization to simultaneously address energy hub layout, sizing and scheduling using a linear formulation, in ENGOPT. 2014: Lisbon, Portugal.
9. Roelofs, M. And Bisschop, J., AIMMS v.4.5.1.229. Available at <http://www.aimms.com>, 2015. Accessed 27 April 2015.
10. Fish, J. C. L., Engineering economics: first principles. 1915, New York. USA: McGraw-Hill Book Company.
11. Bundesamt für Landestopografie, VECTOR25. 2008, swisstopo: Wabern.
12. Brunner, C. U., Wärmebrückenatlas 3, AltbauDetails. 1993, SIA: Zürich.
13. Schweizerischer Ingenieur- und Architektenverein, SIA 2024 (2006): Standard-Nutzungsbedingungen für die Energie- und Gebäudetechnik. 2006, SIA: Zürich.
14. Schweizerischer Ingenieur- und Architektenverein, SIA 380/1 (2009): Thermische Energie im Hochbau. 2009, SIA: Zürich.
15. Weidema, B. et al., The ecoinvent database: Overview and methodology, data quality guideline for the ecoinvent database version 3. Available at [www.ecoinvent.org](http://www.ecoinvent.org), 2013. Accessed 12 January 2016.
16. EnDK – Konferenz Kantonalen Energiedirektoren, Anwenderhandbuch zum GEAK Plus Online-Tool. 2014, EnDK: Muttenz.
17. Bundesamt für Energie BFE, Einmalvergütung und Eigenverbrauch für kleine Photovoltaik-Anlagen. 2014, BFE: Bern.
18. Amt für Energie und Verkehr Graubünden, Leitfaden und Bedingungen für Beitragsgesuche. 2015, AEV Graubünden: Chur.
19. Schweizerischer Ingenieur- und Architektenverein, SIA 2040 (2011): SIA Effizienzpfad Energie, 2011, SIA: Zürich.



## Expanding Boundaries: Systems Thinking for the Built Environment

### MATCHING RENEWABLE ENERGY PRODUCTION AND CONSUMPTION BY MARKET REGULATED DEMAND SITE MANAGEMENT (DSM)

T. Schluck<sup>1\*</sup>, R. Bühler<sup>2</sup>, S. Sulzer<sup>1</sup> and M. Sulzer<sup>1</sup>

<sup>1</sup> Lucerne University of Applied Sciences and Arts, School for Engineering and Architecture, Competence Centre for Integrated Building Technology (HSLU ZIG), Technikumstrasse 21, CH-6048 Horw

<sup>2</sup> Bühler Expert Advisors, Summerhaldestrasse 40, CH-8427 Freienstein

\*Corresponding author; e-mail: thomas.schluck@hslu.ch

#### Abstract

An important cornerstone to reach the goals of the Swiss energy turnaround is the consecutive addition of renewable electrical power sources in conjunction with efficient demand-site management. This development implies shifts in the daily power production and changes in load-management. In the light of the future liberalization of the Swiss electrical market, providers will have to search for new and different business models, which cope with these developments.

Such a new business model was developed by "Change38". It sets local incentives to drive and accelerate the addition of electrical power supplies and storage systems. Its goal is to establish a local market for the ecological added value for renewable energy sources (producers) and to thrive the individual load management between the consumers, respectively prosumers. The model thereby follows a self-regulatory approach and merely gives the necessary framework. It sets monetary incentives for producers to produce and for consumers to consume energy at the right, most valuable time. The developed business model addresses the socioeconomic trend of share economy as well as the sociotechnical trend of industry 4.0.

To evaluate and to refine this business model, a simulation model was developed, which allows calculating all monetary flows and physical balances for every participant on the basis of time series for power production and power demand.

Using Monte-Carlo simulations, the model allowed the energy service provider "Change38" to estimate the risk of its new service and hence to design an economical business case.

#### Keywords:

Business models; start-up; share-economy, electricity; demand-site management; simulations; self-organization, industry 4.0

## 1 INTRODUCTION

Renewable energy systems were identified as a major key technology of the Swiss energy turnaround [1]. However, their integration in large quantities is a big challenge and although technical solutions themselves are available today [2], the monetization of these solutions is often the critical barrier. National subsidies programs try to tackle these economic barriers, but even if they succeed, they are by design only an interim solution. A current example of such a program is the "KEV" (Kostendeckende Einspeisevergütung, i.e. cost-effective feed-in

remuneration), which helped to push the dissemination of photovoltaic systems in Switzerland, but is now financially depleted [3]. Business models, which incorporated the national subsidy, have therefore declined. In addition, the electrical power market is changing. National laws prohibiting the internal consumption of produced electricity were repealed and for the coming years the liberalization of the market is imminent.

To cope with these changes new business models are in quest [4], [5]. Most business models for renewable energy sources trade the

certified proof of origin (labelled electricity) as an indicator for its additional “ecological value” (EV). A business model that goes one-step forward was developed by “Change38” [6] and is already running in a small-scale pilot project in “Gachnang” (canton of Thurgau).

In this model producers and consumers are clustered in local pools and their production and demand is continuously monitored. Each participant has access to visualizations of his actual status within his pool. This business model can forgo any certified proof of origin; power is distributed directly and isochronally among the peers. An objective and core element of this model is to increase the self-sufficiency of each pool that directly addresses the socio-economical trend of sharing and the socio-technical trend of the industry 4.0 by matching demand and production [7], [8]. To reach this goal financial incentives are set for the participating producers as well as for the consumers. The consumer agrees on a small fee on each kWh, which he did not receive from a producer within the pool. The producer receives a financial reward on each kWh of his production, which is consumed within the pool – along with a small base rate for each produced kWh. While the consumers are handled equally in respect to the distribution of the pooled production, the model makes differentiates between the producers. Producers are distinguished by their pool entry date, such that a producer who joined early is more privileged in the distribution process (first come – first serve). This creates an incentive for producers to rather join unbalanced pools and fill in supply gaps, to invest in complementary technologies like storage systems or create additional pool that needs and attracts new costumers. The long-term perspective is to cluster local renewable energy sources and consumers such that most of the electricity is consumed locally (and thus on a low level of the electricity grid). The business model is shown in Fig 1. The three main actors are Change38, the producers and the consumers.

Consumers cannot be burdened with too high costs, while producers ask for an attractive additional income. Change38 needs to balance these contrary interests. A simulation tool was

developed to investigate the interdependencies within the model and to find possible and for each stakeholder justifiable constellations. Ideally a high percentage of self-consumption and self-sufficiency is reached while satisfying producers and consumers’ monetary expectations.

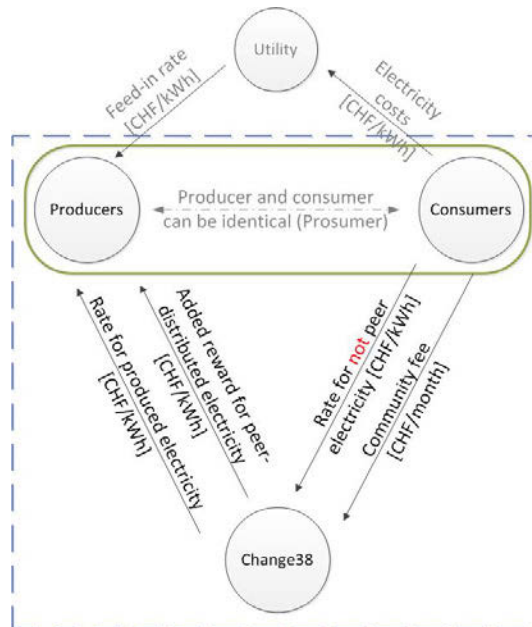

Fig 1: The business model «Change38» given in the blue frame. Producers and consumers are clustered in pools (green). The contracts to the utilities are kept outside the business model and are left untouched.

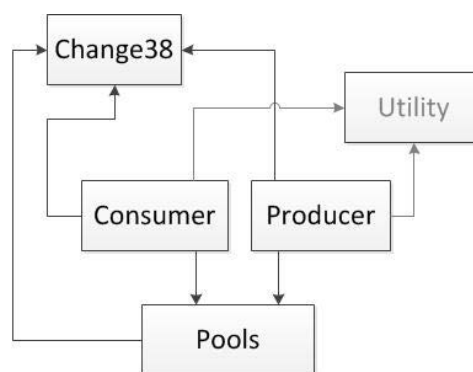

Fig. 2: Interrelations within the framework that was used to represent the business model. Each participant’s role equals an own class.

Inputs	Change38	Fees and rates (see Fig.1).
	Utility	Fees and rates (see. Fig.1).
	Consumer	Annual demand profiles with hourly resolution for: <ul style="list-style-type: none"> <li>• Equipment, lighting, air-conditioning. (if applicable)</li> <li>• Heat pumps including seasonal performance. (If applicable)</li> </ul>
	Producer	Nominal power. Annual production profiles with hourly resolution.

		Self-consumption rate. Entry date.
<i>Outputs</i>	Change38	Earnings and expenses.
	Utility	Earnings, expenses and back payments.
	Consumer	Power allocated from peers (hourly profile). Earnings and expenses (hourly profile).
	Producer	Power allocated to peers. Earnings and expenses.
	Pool	Percentage of self-consumption. Percentage of self-sufficiency.

*Tab. 1 : In- and outputs of the simulation framework.*

<i>Parameters</i>	<i>From</i>	<i>To</i>	<i>Values</i>
Rate for not peer electricity [CHF/kWh]	Consumer	Change38	[0.02, 0.04, 0.06]
Community fee [CHF/month]	Consumer	Change38	[10, 14, 20]
Electricity costs [CHF/kWh]	Consumer	Utility	[0.2, 0.3, 0.4]
Feed-in rate [CHF/kWh]	Utility	Producer	[0.02, 0.04, 0.06]
Rate for produced electricity [CHF/kWh]	Change38	Producer	[0.01, 0.03, 0.05]
Added reward for peer distributed electricity [CHF/kWh]	Change38	Producer	[0.03, 0.06, 0.09]
Number of clustered producers			[15, 50, 100]
Number of clustered consumers			[30, 100, 200, 500]
Demand of consumers [kWh/a]			[2200, 3500, 5500, 7500]
Nominal power producers [kWp]			[10, 30, 100]
Percentage of self-consumption producer			[0.15, 0.3, 0.6]

*Tab. 2: Parameters varied during the Monte-Carlo simulations.*

## 2 METHOD

The business model was set-up in an object-oriented framework that allowed for the initialization of any arbitrary constellation of pools, consumers, producers and utilities. Fig. 2 shows the framework in principle and the underlying dependencies of the different classes.

Table 1 gives an overview about the in- and outputs of the framework. Consumers and producers are described by annual profiles (for residential use in this case). As comprehensive live data was not available at the time of writing, demand profiles from [9], [10] were aggregated that considered lightning, equipment and ventilations. The user's possible change in conduct was not taken into account. In cases of domestic heating using heat pumps typical demand profiles can be superposed.

In this study only photovoltaic systems (PV) were considered. Production profiles were generated [11] for the pilot area with different nominal power, ranging from 4 kWp to 100 kWp. The producer's self-consumption is addressed in the simulation framework.

For each time step, the peer-distributed electricity of each pool member is calculated. All energy

flows in and out of a pool are monitored, which – in its sum – gives the considered pools percentage of self-consumption and self-sufficiency. Based on these findings the earnings and expenses of each pool member are calculated.

To address the question what pool constellations are most favourable, a Monte-Carlo approach was chosen. About eleven parameters – listed in detail in table 2 – were varied. The Monte-Carlo simulation comprised about 2000 pool constellations that were randomly established.

The pool constellations then were reviewed and analysed in respect of the following main criteria:

- A positive and possibly high financial outcome for Change38 and the participating producers.
- Tenable costs for the consumers.
- No overproduction within the pool, i.e. the ratio of production and consumption is equal or less 1.
- A high percentage of self-consumption (Percentage of Self-consumption is the ratio of the total self-consumed energy per year to the total produced energy per year. For the sake of convenience, it will

often be referred to as “self-consumption” throughout this work.)

- A high percentage of self-efficiency (Percentage of self-sufficiency (autarchy) is the ratio of the total self-consumed energy per year to the total consumed energy per year. For the sake of convenience, it will often be referred to as “self-sufficiency” throughout this work.)

The main idea of this business model is to support renewable energy sources utilizing economic means. Some constraints result from this approach, like balancing a pool: On the one hand, there should not much more produced electricity in a pool as actual needed by the pool members. On the other hand, a considerable amount of electricity should be supplied within the pool. Thus, at least half of the demand within a pool was expected to be produced within the pool itself and overproduction of a pool was prohibited.

### 3 RESULTS

Fig 3. and Fig. 4. show the ratio between production and consumption in relation to the pools self-sufficiencies and self-consumptions. The profitability for Change38 is shown in colour and size. (The size of the scatter points indicates the magnitude of the earnings, respectively losses, and the colour if they were positive (blue) or negative (red)).

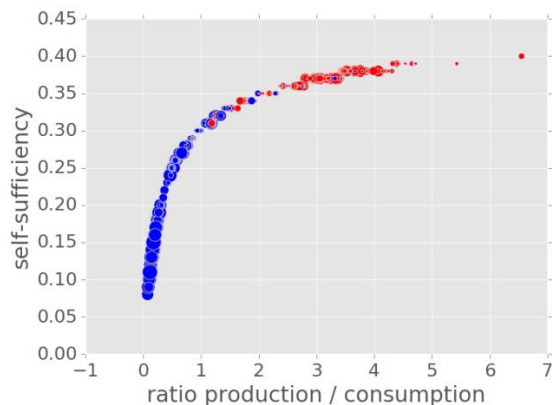

Fig. 3: The relation between self-sufficiency and the production/consumption ratio of the simulated pools. In blue financially profitable constellations for Change 38. In red unprofitable pools.

The additional income generated for participating producers is on average 0.127 CHF/kWh and varies between 0.042 CHF/kWh and 0.24 CHF/kWh. The expenses for the consumers vary between 0.034 CHF/kWh and 0.105 CHF/kWh. Note, that these expenses add to the regular costs charged by a consumer’s utility.

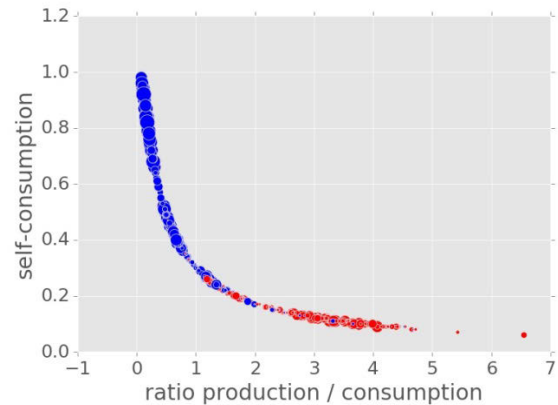

Fig 4: The relation between the self-consumption and production/consumption ratio of the simulated pools. In blue financially profitable constellations for Change 38. In red unprofitable pools.

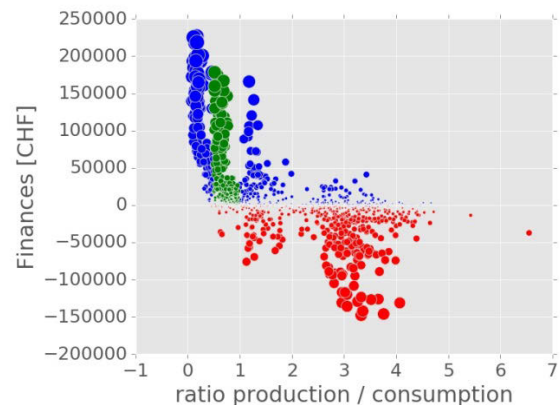

Fig. 5: The Ratio of production / consumption of the different pools against the financial balances of Change38. In red are unprofitable, blue profitable pools. In green the pools left after filtering for the given criteria.

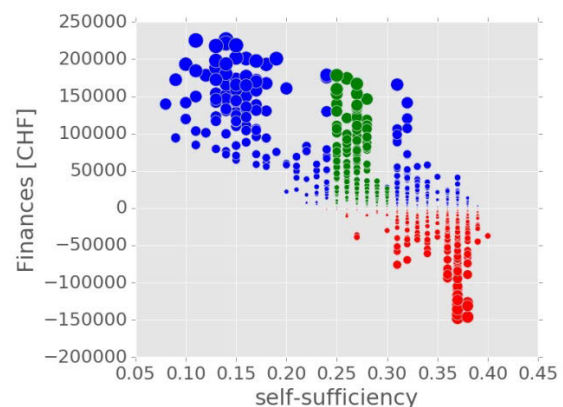

Fig. 6: Self-sufficiency versus Change38 finances. Colouring similar to Fig. 5.

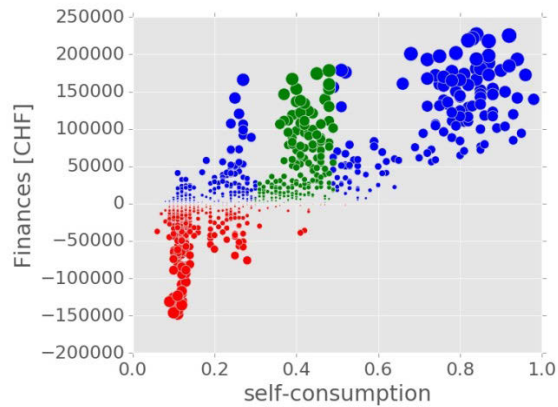

Fig. 7: Self-consumption versus Change38 finances. Colouring similar to Fig. 5.

For the consumers the resulting pricing structures of every pool constellation was found to be of tenable nature. The situation of the producers is not problematic. In any constellation the producer makes money and improves its investment.

However, the situation of Change38 is more sensitive. Some pool configurations are completely undesirable for the start-up company, other have the potential for high financial gains as can be seen in Fig. 5 to 7. The blue depicted pools show financially profitable configurations, while the red pools lead to losses throughout a year.

Filtering for pools that satisfyingly fulfil the economic and ecological criteria are shown in green. These pools produce at least 50% of their demand within themselves and do not overproduce. The pools self-sufficiency was found at about 25% and their self-consumption varying between 30% and 50%.

#### 4 DISCUSSION

The chosen subsets of pools seem to be a valid compromise between the financial interests of Change38 and the ecological goals. The antagonizing behaviour of the self-consumption rate and the self-sufficiency rate dominates the systems behaviour. This contradictory behaviour becomes obvious when comparing Fig. 3 and Fig. 4. The self-sufficiency of the pools is highly correlated to the ratio of annual production to annual consumption (correlation factor of 0.87). Fig. 3 shows clearly, that an overproduction is needed for a reasonably high self-sufficiency. This reflects the circumstance that all production sites in this study were chosen to be photovoltaic systems. Technologies with more complementing production profiles should buffer and diminish this behaviour. Furthermore, the self-consumption is highly anti-correlated to the production-consumption-ratio (correlation factor of -0.84), which plainly states, that the more is produced the less can be used-up within the pool.

When focusing solely on the monetarisation and the optimization of profits for Change38 an arguable contradiction raises. If targets on self-consumption, self-sufficiency and production-consumption balancing are neglected or even dropped, earnings could be increased by 20% – plainly by setting up pools with only a few producers and many consumers (pools with low self-sufficiency, respectively high self-consumption. Compare with Fig. 5, 6 and 7). Such a development must be precluded by additional measures like a guaranteed self-consumption, a minimal production-consumption ratio or similar constrains.

#### 5 SUMMARY AND OUTLOOK

In this study a business model to monetarize and strengthen the distribution of renewable energy sources was explored by means of computer modelling and simulation. The business model clusters producers and consumers in pools and sets financial incentives to consume from and produce for the pool. To gain an understanding of the business model's dynamics and the resulting consequences for the different actors a modelling framework was developed. The framework allows for the initialization of possible pool constellations and calculates the power distribution within the pool as well as the financial earnings and expenses of each participant. By means of Monte-Carlo simulations a set of 2000 pools was created and finally analysed on the basis on given criteria.

In a next step, the gained insights will be used to adapt and refine the business model as well as further development of the framework by adding additional models for e.g. storages, CHPs, heat pumps. Furthermore, seasonal differences will be taken into account. Live-data from the pilot project will help to optimize the business case, but also to develop approaches to model the behavioural changes in customer's conducts.

#### 6 ACKNOWLEDGMENTS

Our acknowledgement to the CTI, which founded and supported this study in the context of the SCCER FEEB&D. Also our sincerest thanks to our industrial partner "Change38".

#### 7 REFERENCES

1. Bundesamt für Energie. (2016) Energiestrategie 2050 des bundes. Accessed: February 2016. Available: <http://www.bfe.admin.ch/themen/00526/00527/-index.html?lang=de>
2. H. Farhangi, "The path of the smart grid," *Power and energy magazine, IEEE*, vol. 8, no. 1, pp. 18–28, 2010.

3. "Warteliste der kostendeckenden einspeisevergütung." 2016, accessed: February 2016. Available: [https://www.swissgrid.ch/swissgrid/de/home/experts/topics/-renewable\\_energies/remuneration\\_re/crf/-registration\\_to\\_implementation/waiting\\_list.html](https://www.swissgrid.ch/swissgrid/de/home/experts/topics/-renewable_energies/remuneration_re/crf/-registration_to_implementation/waiting_list.html)
4. OECD for Economic Co-operation and Development, *Harnessing variable renewables: A guide to the balancing challenge*. OECD Publishing and International Energy Agency, 2011.
5. E. Facchinetti and S. Sulzer, "General business model patterns for local energy management concepts," *Frontiers in Energy Research*, vol. 4, no. 7, 2016. [Online]. Available: [http://www.frontiersin.org/-energy\\_systems\\_and\\_policy/10.3389/-fenrg.2016.00007/abstract](http://www.frontiersin.org/-energy_systems_and_policy/10.3389/-fenrg.2016.00007/abstract)
6. T. Schluck, "Cleverer Tauschbörse," *Haustech*, 2015.
7. H. Lasi, P. Fettke, H.-G. Kemper, T. Feld, and M. Hoffmann, "Industry 4.0," *Business & Information Systems Engineering*, vol. 6, no. 4, p. 239, 2014.
8. P. Palensky and D. Dietrich, "Demand side management: Demand response, intelligent energy systems, and smart loads," *IEEE Transactions on Industrial Informatics*, vol. 7, no. 3, pp. 381–388, Aug 2011.
9. S. Merkblatt, "2024 (2006): Standardnutzungsbedingungen für Energie- und Gebäudetechnik," Zürich, Schweizerischer Ingenieur-und Architektenverein.
10. S. Hoffmann and S. Sulzer, "Leuchtturmprojekt Hybridwerk Aarmatt," *Schlussbericht Bundesamt für Energie*, 2014.
11. "Velasolar. Polysun Simulationssoftware" accessed February /2016. Available: <http://www.velasolaris.com/>





## HOLISTIC OPTIMIZATION OF URBAN MORPHOLOGY AND DISTRICT ENERGY SYSTEMS

C. Waibel<sup>1, 2\*</sup>, R. Evins<sup>1, 2</sup>, J. Carmeliet<sup>2, 3</sup>

<sup>1</sup> Laboratory for Urban Energy Systems, Empa, Ueberlandstrasse 129, 8600 Duebendorf, Switzerland

<sup>2</sup> Chair of Building Physics, ETHZ, Stefano-Franscini-Platz 5, 8093 Zurich, Switzerland

<sup>3</sup> Laboratory for Multiscale Studies in Building Physics, Empa, Ueberlandstrasse 129, 8600 Duebendorf, Switzerland

\*Corresponding author; e-mail: christoph.waibel@empa.ch

### Abstract

This study presents a new optimization framework of both urban morphology as well as district energy systems. It is entirely embedded within the 3D-CAD software Rhinoceros / Grasshopper. Here, Mixed Integer Linear Programming (MILP) and Simulated Annealing (SA) are applied to solve the design and operation of a district energy system (DES) as well as the geometric design of the urban morphology.

Two approaches are compared: In the first, urban morphology is optimized using SA, and subsequently the DES for the final urban morphology is optimized using MILP. In the second approach, the district energy system optimization using MILP is nested within the urban morphology optimization using SA. Therefore, the higher level optimizer (SA) can exploit information from the lower level optimizer (MILP) and hence find better solutions. Results show that rather than addressing urban morphology and DES consecutively, both levels should be evaluated interdependently – especially for high carbon reduction targets. It is shown that urban planning should integrate both energy systems and morphology into a holistic design process.

### Keywords:

Energy Hub; Urban Morphology; Optimization; District Energy Systems

## 1 INTRODUCTION

Increasing urbanization and population growth will increase the need for new urban development, especially in emerging cities. There is a huge potential in climate change mitigation and adaptation by designing these new urban districts to be energy efficient. This includes reducing energy demand for space conditioning and lighting by applying passive building and urban design strategies, including careful optimization of glazing ratios, building shape and configuration, natural ventilation and overshadowing. Also, the potentials for harvesting electricity with building-integrated photovoltaics can be increased depending on the urban morphology [1].

Finally, an important aspect to reducing overall lifetime cost and emissions is the appropriate selection and sizing of district and building

energy systems which include technologies such as combined heat and power (CHP) and borehole thermal energy storage, etc. [2]. For this the “energy hub” model [3] can be used to size the components as well as solve the operational optimization to balance demands and supplies for every time step.

Previous studies have dealt with the optimal design and operation of each of the above mentioned categories independently, where building/urban energy demands are assumed to be fixed inputs for the optimization of energy systems [4]. However, the question arises if there exist interdependencies which, when considered simultaneously, lead to significantly different optimal design solutions.

The issue of interdependencies between building design and energy system design and operation has been studied in [5], where a multilevel

optimization framework was developed and applied to an office building case study. Here, building design focussed on fabric construction properties, such as glazing ratio and insulation thickness. It was shown that this approach can exploit synergies between building and systems level.

## 2 METHODOLOGY

In this study a holistic optimization framework of both urban morphology as well as district energy systems (DES) is presented. A new optimization framework entirely within the 3D-CAD software Rhinoceros / Grasshopper has been developed, where Mixed Integer Linear Programming (MILP) and Simulated Annealing (SA) are applied to solve the design and operation of a DES as well as the geometric design of the urban morphology.

### 2.1 Geometric Optimization

SA is a metaheuristic optimization method developed by Kirkpatrick [7] inspired by the cooling process of liquid metal atoms. As SA solver, the native Grasshopper component Galapagos is used. The objective for the SA is to maximize profits for the developers of the new urban configuration:

$$\text{Max Profit} = P_{rent} - C_{DES} \quad (1)$$

$P_{rent}$  describes the annual revenues from rent.  $C_{DES}$  is the total cost for the district energy system including operation. The calculation method for  $C_{DES}$  varies between the consecutive and the nested approaches and is explained in the next section.

The objective function value is not necessarily accurate, but serves as an incentive for the optimization process to increase total area of the neighbourhood. Increasing urban density and counteracting urban sprawl is also an intended development for reducing overall emissions [8].

### 2.2 Consecutive and Nested Optimization

Two different approaches are compared:

- Consecutive optimization of urban morphology then district energy systems
- Nested optimization of district energy systems as part of the urban morphology optimization.

#### Consecutive Optimization

The consecutive approach (shown in Fig. 1, left) has two distinct optimization stages. In the first stage the SA is optimizing the geometry of the urban morphology. After the SA terminates, the final solution is used as input in the second stage for the DES optimization.

During the first stage the operational component of  $C_{DES}$  is evaluated using idealized energy demands for space heating, cooling and lighting

(see chapter 3). For the second stage,  $C_{DES}$  is re-evaluated for different carbon targets (but for the same final urban morphology) using the energy hub model, described in chapter 3.

#### Nested Optimization

The algorithm for the nested approach is shown in Fig. 1, right. Here, the SA again decides on the geometry of the urban morphology. The geometrical configuration is evaluated for energy demands using EnergyPlus and for solar potentials on the façades and the roofs using a custom model (see section 2.4). The demands and potentials serve as inputs for the energy hub model, which calculates  $C_{DES}$  subject to a pre-set carbon target. The entire nested optimization process is repeated for different carbon targets.

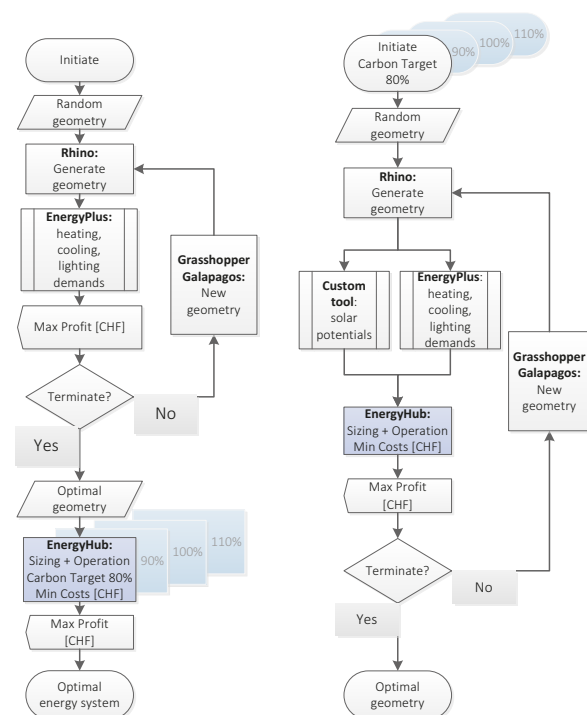

Fig. 1: Consecutive (left) and nested (right) optimization.

### 2.3 Demand Model

EnergyPlus is applied via the Grasshopper plugin ArchSim [9] to simulate ideal hourly heating, cooling and lighting energy demand. The energy demands of all buildings and zones are aggregated. Cooling demands are converted to electricity demands.

### 2.4 Solar Potentials Model

Hourly annual solar potential profiles for each building façade and roof are obtained with a custom model fully implemented in Rhino Grasshopper ([Online] Available: <https://hues.empa.ch/>). This model factorizes both direct normal radiation and diffuse horizontal radiation from a weather file using detailed obstruction calculations of mesh surfaces for three distinct days of the year – summer solstice, winter solstice and equinox – using backward

ray-tracing and then interpolates these obstruction levels for the remaining days of the year.

The advantage of such an approach is higher resolution geometric information of meshed surfaces, especially important in complex urban situations. Computing times are very low (In this work about 2.5 seconds for annual hourly solar profiles for all four buildings with four façades and one roof respectively, each surface discretised into a 10x10 Mesh, on a Win7 Intel Xeon E5-2643 3.30 GHz).

### 2.5 Energy Hub Model

The energy hub concept describes a modelling and optimization framework for multicarrier energy systems, where different energy carriers, conversion and storage technologies can be combined for flexible operation, thus enabling energy, cost and emissions savings [3].

In this study, the energy hub model is implemented as a custom Rhino Grasshopper component, since using Rhino facilitates both the geometrical design of urban morphologies, as well as building energy simulations.

The energy hub component is based on a generic VB.Net implementation ([Online] Available: <https://hues.empa.ch/>) and uses IBM ILOG CPLEX as solver. It takes hourly energy demands and hourly solar potentials from all building façades and roofs as input. The carbon reduction target in % to a reference value can be pre-set, which then acts as an equality constraint during the optimization. The energy hub component formulates a Mixed Integer Linear Programming (MILP) problem to solve system sizing and operation variables of the DES.

The objective is to minimize cost in CHF, where the costs consist of annual fuel cost ( $C_{fuel}$ ), annual cost for electricity purchased from the grid ( $C_{elec}$ ), annual operational and maintenance cost for the systems ( $C_{om}$ ), capital and installation cost for the systems ( $C_{capital}$ ) annualized over each technology's lifetime with an interest rate of 8%, minus the annual revenues from selling electricity to the grid ( $C_{sell}$ ):

$$\text{Min } C_{fuel} + C_{elec} + C_{om} + C_{capital} - C_{sell} \quad (1)$$

Constraints in the MILP are formulated for energy balance (demand equals supply), carbon target to a reference value (carbon offset for feed-in electricity is allowed), solar availability, façade / roof area availability, and technology performance (e.g. maximum charging rate or minimum state of charge for storages and minimum load for combined heat and power).

For computational reasons, the annual hourly demands and solar potentials, each consisting of 8760 values for each hour of the year, are averaged to 288 hours to represent one day for each month of the year. A drawback of using only

288 hours as 12 representative days for the year is that no long-term seasonal storages can be considered. The disadvantage with averaging data is the loss of information for typical profiles. However, since the schedules for internal gains are identical for all zones and buildings (no stochastic profiles), averaging data is acceptable since typical days would create unrealistic high peaks.

### 3 CASE STUDY

A case study is used concerning a new development consisting of four office buildings on a site in the city of Zurich (corner of Wilhelmstrasse and Limmatstrasse), measuring 81 x 81 m at its perimeter.

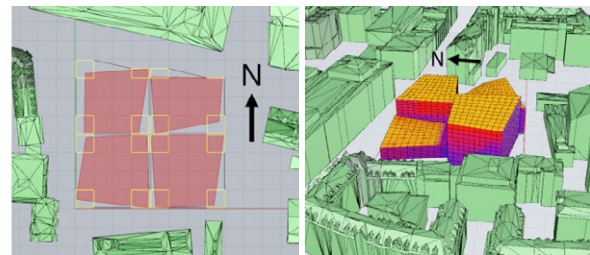

Fig. 2: Top (left) and perspective (right) views of the urban geometry model, with solar radiation calculation for summer solstice day. Left: yellow outlines indicate bounds for building footprint design variables.

Fig. 2 shows the 3D-model, with the urban context in green (taken from a 3D model of the city [6]) and the four office buildings with calculated solar radiation for a summer day. The model is set up using Rhino / Grasshopper native components. The decision variables are the building outlines defined by four corner points as x/y coordinates per building and the number of storeys (1 to 6, matching the adjacent buildings) with 4m height per storey. One corner point's y-value is fixed due to site constraints, therefore in total 35 decision variables are to be optimized by the SA. The total floor area of all four buildings can range from 1.600 m<sup>2</sup> up to 34.340 m<sup>2</sup>, depending on the building footprints and number of storeys. Window to wall ratio is set fix to 50%.

$P_{rent}$  was set to 70 CHF/m<sup>2</sup>. In the idealized system costs to cover the heating demands are calculated assuming a reference gas boiler with  $\eta=0.94$  and 0.09 CHF per kWh gas. Cooling is provided with an air conditioning system with a COP = 3. Electricity is purchased for 0.12 CHF during off-peak and 0.24 CHF during peak hours. A Zurich TRY weather file for the city centre was used. The heavyweight constructions for roof, floor, walls and windows match the SIA 380/1 [10] minimal requirements.

To increase the influence of building geometry on the energy demand, natural ventilation is allowed during occupied hours, and lighting is dimmed

according to daylight availability. Night ventilation was not allowed due to security reasons. The control strategies are given in Table 1. Schedules for internal gains (occupancy, equipment and lighting) are according to SIA for office buildings [11]. Each building volume is divided into 4m high stories. Each storey is described by a single thermal zone. Schedules for all zones are identical.

Technologies include combined heat and power (CHP), heat pumps (HP), gas boiler, photovoltaic panels (PV), air conditioning (AC), batteries and thermal storages (TES). Fig. 3 describes the considered energy hub.

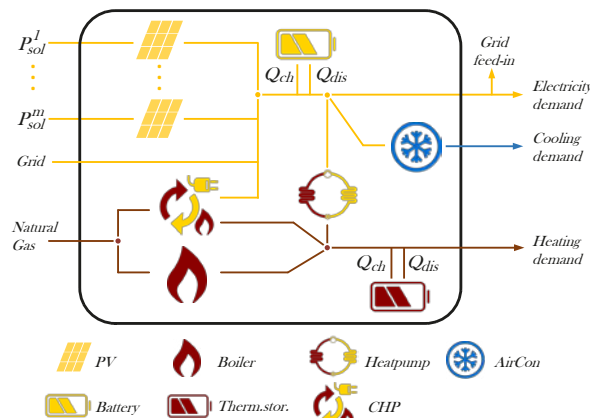

Fig. 3: Energy hub of the case study.

#### Model Parameters

Cost parameters are given in Table 2, carrier emission factors (EF) and prices in Table 3. Emission parameters of the reference building are 100 kWh/m<sup>2</sup>a for heating and 120 kWh/m<sup>2</sup>a for electricity [12] using a reference gas boiler with  $\eta = 0.94$ , resulting in 96.5 kgCO<sub>2</sub>/m<sup>2</sup> total specific carbon emissions. Carbon targets are set to 80%, 90%, 100% and 110% reduction from the reference. The model is solved to a MILP optimality gap of 5%.

Control mode (during occupation)	
Cooling	Target 23 °C
Heating	Target 22 °C
Nat.vent.	Open at 21 °C
Dimming	Target 500 lx
Shading	Activate at 200 W/m <sup>2</sup>

Table 1: Control set-points.

Equipment	Efficiency/COP	Unit Cost [CHF/kW]
AC	3	360
Boiler	0.94	200
Heat pump	3.2	1000
CHP	$\eta_{el}=0.3 / \eta_{th}=0.519$	1500
PV	0.18	300 CHF/m <sup>2</sup>

Battery	0.92 charging/disch.	600
Thermal Storage	0.9 charging/disch.	100

Table 2: Parameters of devices.

Carrier	Carbon factor / price
Natural gas EF	0.237 kgCO <sub>2</sub> /kWh
Natural gas price	0.09 CHF/kWh
UCTE-mix EF	0.594 kgCO <sub>2</sub> /kWh
UCTE-mix price	0.12 off-peak / 0.24 peak CHF/kWh
Feed-in tariff	0.14 CHF/kWh

Table 3: Parameters of carriers.

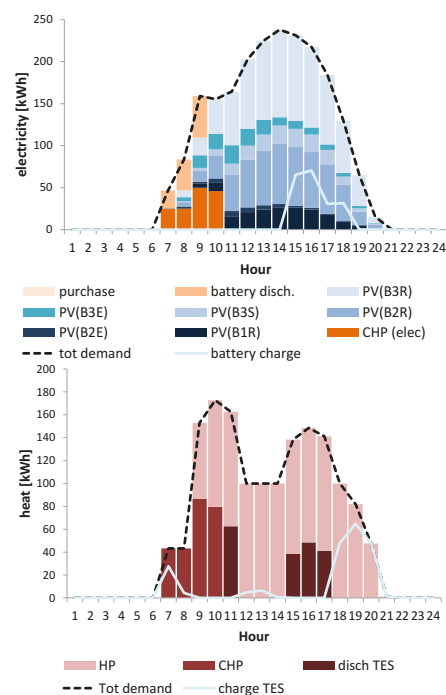

Fig. 4: Example energy balance for electricity (top) and heat (bottom), average March day.

#### Example Operation Schedule

The formulated MILP solves optimal hourly control schedules of the technologies, as well as technology choice and systems sizing. Example control schedules for heating and electricity for an average March day are shown in Fig. 4, including a technology breakdown on how the demand is supplied. The electricity demand includes charging of the battery (TES for heating demand respectively) and electricity sold to the grid.

## 4 RESULTS

To account for the stochasticity of the SA solver, multiple runs have been conducted. The consecutive algorithm was run 8 times and for each final solution the energy hub was solved for

different carbon targets. The nested algorithm was run 3 to 5 times per carbon target. All optimization runs were terminated after 24 hours on a Win7 8-core Intel Xeon E5-2643 3.30 GHz with 128 GB RAM; four different runs were calculating at the same time per session. EnergyPlus accounted for most of the computing time, taking ~6 minutes for four buildings. The MILP solved within ~5 seconds.

Fig. 5 shows the final solutions of all runs for both methods plotted over the objective function value and the carbon reduction target. Red dots indicate solutions of the nested method. The black lines connect between different carbon targets, originating from individual solutions of the consecutive method. It can be seen that while for low carbon targets the optimal solutions of both the nested and the consecutive method are similar, for high carbon targets the nested method consistently finds better solutions. Especially with 110% carbon reduction, using the consecutive method results only in solutions which create losses, whereas the nested method finds solution with profits around 500.000 CHF.

While the found solutions for the 80% and 90% carbon targets are well distributed for both methods, the solutions for the 100% and 110% carbon targets found by the nested method are closely clustered at higher profits. This again indicates that the nested method can consistently find better solutions especially for high carbon targets.

Fig. 6 shows the amount of electricity purchased and sold from and to the grid, for both the nested and the consecutive method. For the consecutive method, the one best solution found without carbon target is used for calculating the final DES using the energy hub with different carbon targets. It can be seen that in order to meet the carbon targets, in the consecutive method more electricity generated by PV or CHP has to be fed into the grid than in the nested method. Also, the amount of electricity purchased from the grid is higher for the consecutive method.

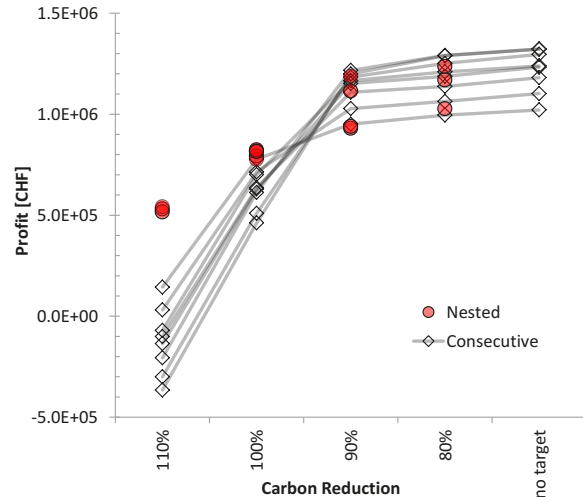

Fig. 5: Profit for final solutions of all runs.

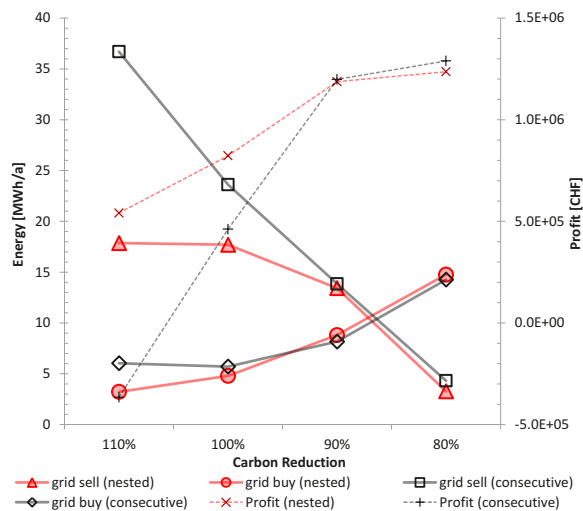

Fig. 6: Electricity purchased and sold to the grid.

Fig. 7 and 8 show the choice of energy technologies and their sizing for both the nested and consecutive method and for different carbon targets. For low carbon targets, both methods choose boilers, low capacities of PV, CHP and storages. While the capacity of the AC is constant in the consecutive method, in the nested method it is reducing, since the morphology can react to the energy system during the optimization. It is striking that in the consecutive method the capacity of the battery is drastically increasing with high carbon targets, while for the nested method it is not – for the same reason as for the AC: the carbon targets in the consecutive method have to be reached solely through the DES, whereas in the nested method the urban morphology (demands and potentials) can be optimized hand in hand with the DES.

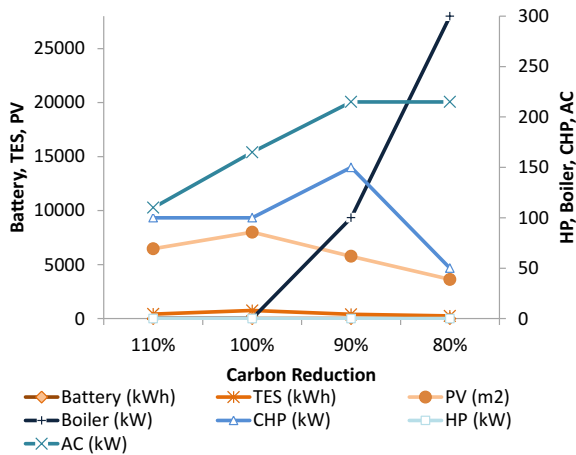

Fig. 7: Sizing and selection of technologies, nested optimization.

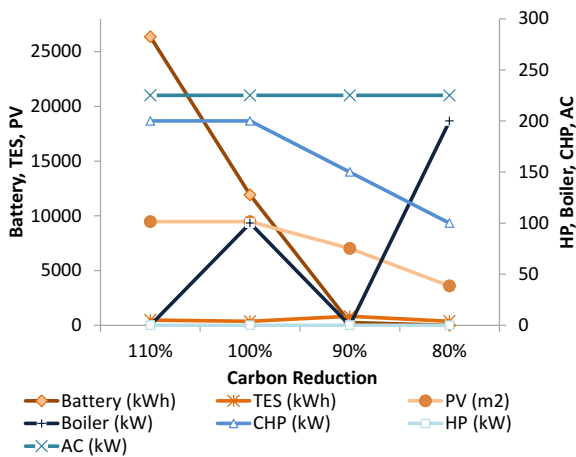

Fig. 8: Sizing and selection of technologies, consecutive optimization.

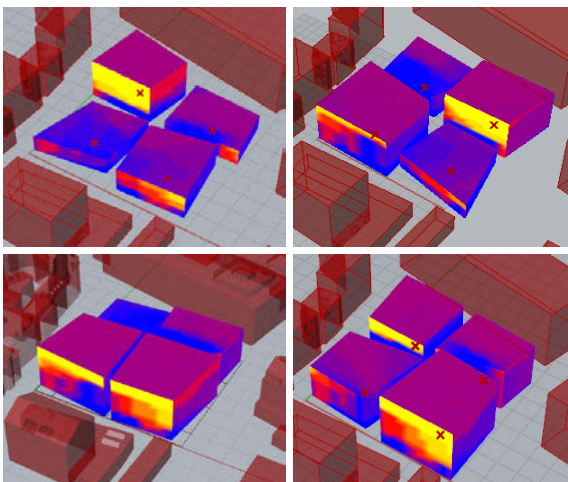

Fig. 9: Geometries of the best solutions found by the nested method for 110% (top left), 100% (top right) and 90% (bottom left) carbon reduction target, as well as the best solution found by the consecutive method (bottom right).

Fig. 9 shows the optimized building geometries for the best solution found by the nested method with 110%, 100% and 90% carbon reduction respectively, as well as the best solution found of

the consecutive method before energy hub optimization. Solar radiation values for winter solstice are shown on the building surfaces. Different geometrical characteristics for each of the shown solutions can be identified, such as configurations where high buildings alternate with low buildings, or certain spacing between the volumes presumably to encourage daylight penetration. It is striking that the optimized geometries of the consecutive method are very similar to those of the nested method with 80% carbon reduction. However, the higher the carbon target gets with the nested method, the more geometric differences to the consecutive method are noticeable.

In general, increasing carbon targets lead to lower density. Characteristics of the optimized solutions of 80% carbon reduction target are narrow spacing between the buildings and large heights, whereas for higher carbon reduction target the spacings are increased and the heights reduced.

## 5 DISCUSSION AND FURTHER WORK

The results show that considering the design of the DES together with the optimization of urban morphology via a nested method leads to more profitable solutions for high carbon targets. This can be explained due to the fact that for low carbon targets the reference system calculation (assuming a gas boiler and electricity from the grid) is close to the optimal DES decided by the energy hub MILP, therefore little benefits can be expected from the energy hub MILP during the morphology optimization. However, for high carbon targets more sophisticated systems are necessary and the interplay between demands/potentials and DES becomes relevant. This can be adhered by careful orientation and shaping of the buildings, which influence solar potentials, but also careful trade-off between total floor area (density) and related costs to reach the carbon targets.

It is expected that the sensitivity of urban morphology on the optimal solutions in reality is even higher, since many relevant factors have not been considered in this study. Especially accounting for micro-climatic effects in the urban context can have a significant impact on the building energy demands [13]. For example, the EnergyPlus simulations use the same wind pressures independent of how they are obstructed by their neighbouring buildings, which if considered would have an impact on the natural ventilation potentials.

Further work should address issues of micro-climate modelling in the urban context and allow more complex zoning of the building volumes. Also, losses and costs implied by the topology and typology of thermal networks [14], grid constraints [15] and a higher temporal resolution

of at least 8760 hours instead of 12 average days to account for long term seasonal storages, will be included.

Allowing the acquisition of carbon credits and using land rent models or more precise data on rents should be considered to account for a more realistic trade-off between built density and the design of the DES for certain carbon targets. Hence, in areas of high rents, e.g. in central business districts (CBD) denser and still profitable morphologies would be possible while fulfilling the carbon targets by investing more in carbon credits instead of investing in more PV and CHP.

## 6 CONCLUSION

This study presents a novel framework for holistic urban morphology and district energy systems optimization, entirely within the 3D NURBS modelling software Rhino Grasshopper, a program widely used by architects and urban designers.

It has been shown that especially for high carbon reduction targets it is crucial to consider both urban morphology and DES hand in hand. In fact, only the holistic nested optimization method enabled designs, which generated profit instead of costs. Only in this way can knowledge of sophisticated multi-energy systems (energy hubs) necessary to facilitate the transformation towards carbon neutral cities be exploited in the design of sustainable buildings and neighbourhoods.

## 7 ACKNOWLEDGMENTS

The work is related to the Competence Center – Energy and Mobility “Synergistic Energy and Comfort through Urban Resource Effectiveness” project. This research has been financially supported by CTI within the SCCER FEED&D (CTI.2014.0119).

## 8 REFERENCES

1. M. V. V. Lucon O., et al., “Buildings.In: Climate Change 2014: Mitigation of Climate Change: Contribution of Working Group III to the Fifth Assessment Report of the Intergovernmental Panel on Climate Change,” 2014.
2. UNEP, “District Energy in Cities: Unlocking the Potential of Energy Efficiency and Renewable Energy,” 2015.
3. M. Geidl, G. Koepfel, P. Favre-Perrod, B. Klöckl, G. Andersson, and K. Fröhlich, “Energy hubs for the future,” *IEEE Power Energy Mag.*, vol. 5, no. 1, pp. 24–30, 2007.
4. P. Mancarella, “MES (multi-energy systems): An overview of concepts and evaluation models,” *Energy*, vol. 65, pp. 1–17, 2014.
5. R. Evins, “Multi-level optimization of building design, energy system sizing and operation,” *Energy*, vol. 90, pp. 1775–1789, 2015.
6. “3D Model Zurich.” City of Zurich, Geomatik + Vermessung.
7. S. Kirkpatrick, “Optimization by simulated annealing: Quantitative studies,” *J. Stat. Phys.*, vol. 34, pp. 975–986, 1984.
8. W. S. Revi, A., D.E. Satterthwaite, F. Aragón-Durand, J. Corfee-Morlot, R.B.R. Kiunsi, M. Pelling, D.C. Roberts, “Urban Areas,” *Clim. Chang. 2014 Impacts, Adapt. Vulnerability. Part A Glob. Sect. Asp. Contrib. Work. Gr. II to Fifth Assess. Rep. Intergov. Panel Clim. Chang.*, pp. 535–612, 2014.
9. “ArchSim.” <http://archsim.com/>.
10. “SIA 380/1:2009 Bauwesen – Thermische Energie im Hochbau.” Schweizerischer Ingenieur- und Architektenverein (SIA), Zurich, Switzerland, 2009.
11. “SIA 2024 - Standard-Nutzungsbedingungen für die Energie- und Gebäudetechnik.” Schweizerischer Ingenieur- und Architektenverein (SIA), Zurich, Switzerland, 2006.
12. “Energieeffizienz im Büro.” [Online]. Available: <http://www.energie.ch/buero>.
13. P. Moonen, T. Defraeye, V. Dorer, B. Blocken, and J. Carmeliet, “Urban Physics: Effect of the micro-climate on comfort, health and energy demand,” *Front. Archit. Res.*, vol. 1, no. 3, pp. 197–228, 2012.
14. B. Morvaj, R. Evins, and J. Carmeliet, “Optimal selection and operation of distributed energy resources for an urban district,” in *Proceeding EngOpt 2014*, 2014.
15. B. Morvaj, R. Evins, and J. Carmeliet, “Bi-Level Optimisation of Distributed Energy Systems Incorporating Non-Linear Power Flow Constraints,” in *Proceedings CISBAT 2015*, pp. 859–864.







## Expanding Boundaries: Systems Thinking for the Built Environment

### BUILT FORM DETERMINANTS OF URBAN LAND SURFACE TEMPERATURE: A CASE OF MUMBAI

Surabhi Mehrotra<sup>1\*</sup>, Ronita Bardhan<sup>1</sup>, Krithi Ramamritham<sup>2</sup>

<sup>1</sup>Centre for Urban Science and Engineering, IIT Bombay, India

<sup>2</sup>Computer Science and Engineering, IIT Bombay, India

\*Corresponding author; e-mail: surabhi\_m@iitb.ac.in

#### Abstract

Mega cities like Mumbai are experiencing continuous decline in thermal comfort due to the change in its ecological functions caused by accelerated growth and changes in its built environment. This research conducts an analysis of spatial variation in Built Form types (BFT) of a ward of Mumbai. BFTs are categorised by both their surface properties and built structure. Furthermore, the study establishes linkages between Built Form (BFT) and variations in the Land Surface Temperatures (LST), and identifies significant indicators of urban temperatures. The analysis of built form parameters is done using urban surface cover Indices as well as volumetric indices like 'Building Heights' (BH) and 'Sky View Factor' (SVF). A regression analysis between Built form parameters and LST was carried out for the 'S' ward of Mumbai to understand the correlation of Built up area Index (NDBI) and Vegetation Index (NDVI) with LST. Also a correlation of BH and SVF indices is assessed statistically with LST. Results show a high positive correlation between LST and Built up area (NDBI), while a strong negative correlation was found between LST and vegetation index (NDVI). A correlation of LST with the building heights was found to be insignificant. The regression analysis carried out between SVF (at noon) and LST shows that BFTs with high SVF have a coherence with high LST, whereas high density low rise slum areas having low SVF show high LST. A current study indicates that the surface cover and the built geometry are significant parameters in assessing spatial variations in LST across different BFTs in the city.

#### Keywords

Urban Built Form; Land Surface Temperature; Sky view Factor

### 1 INTRODUCTION

Urban heating in particular is one of the critical issues in urban areas with warm and humid climate like mega cities such as Mumbai. The urban heating poses risks for outdoor activity, disrupts the ecosystem functioning as well as it increases energy use. Built form is one of the major contributors in influencing the temperatures in an urban area. Mumbai is the culmination of varied built form types as a result of spatial and temporal changes in the urbanisation pattern. Thus, his study attempts to identify the significant determinants of Urban Built Form and their linkages with urban the heating phenomenon. Urban 'Built form' is defined by its space

configuration of built structures that have varied forms across space and time and are categorised as 'Built Form Types' (BFT). Different BFTs have different impacts in regulating the temperatures in an area. In this study, we are analysing the change in urban Land Surface Temperature (LST) as key ecosystem service that impacts the quality of life in urban areas with respect to BFTs. As described by [1], the LST varies from place to place as it depends on the surface and geometry of a built area. The buildings, roads, vegetation etc. form the surface of the urban area that contributes to the heat energy exchanges in the city [2]. The urban heating phenomenon is caused due to influences of a net radiation flux in the near-ground surface of urban areas[3]. The

higher level of sensible heat fluxes is caused by changes in land cover caused by the removal of the original vegetated areas that have high reflectivity and low thermal capacity [4] [5].

Urban Built Form as a spatial unit can be well understood at a neighbourhood scale[6]. It is the scale that defines both function and form of the built area. At neighbourhood scale, the land surface properties were analysed using vegetation and built-up indices. Built form structure was understood using 'Built Height' and Sky View Index (SVF). SVF provides the net radiation flux of a neighbourhood and its conversion to land surface temperatures. It also implies the exchange of energy within the atmosphere that varies with built form geometry and placement [9]. Therefore, these indices that determine the Urban Built Form are useful in analysing the thermal comfort of outdoor built environments.

The objective of the study is listed as follows:

- To categorise Urban Built Form Types (BFTs) based on the surface and form properties
- To recognise spatial distribution of LST over a ward of Mumbai
- To identify parameters and variables to study relationships between Urban Built Form and LST
- To establish linkages between Urban Built Form parameters and LST

## 2 STUDY AREA

In order to understand variations in ecosystem services with respect to changes in Urban Built Form characteristics, the built neighbourhoods of 'S' ward of Mumbai were analysed. The 'S' ward is the central ward and it creates an ideal system boundary of ecosystems for the study with a lake and a thick vegetation cover at its north. It has different built forms that represent the transforming urban form characteristics of Mumbai. The ward thus serves as an appropriate testing ground for establishing relationships between Urban Built Form and LST.

Figure (1) below depicts the area under study, the 'S' ward of Mumbai. The ward is divided into 250m X 250m grids which form the basic unit for analysis. The 'S' ward covers an area of 64 sq.km and has a population of 7, 43,783.

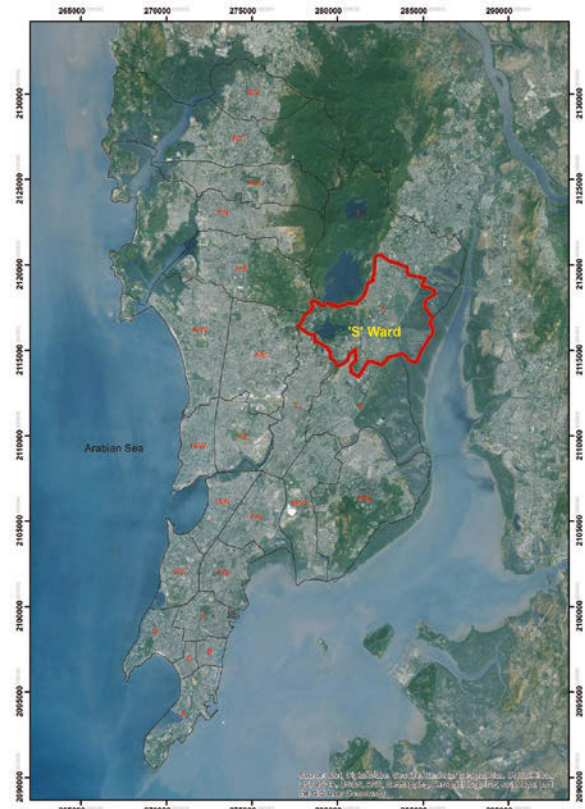

Fig. 1: Mumbai city and the study area, the 'S' Ward, as seen on Google Earth Map 2016.

## 3 METHODS AND MATERIAL

### 3.1 Methods and data sources

Variation in land surface temperatures are a continuous spatial phenomenon and cannot be analysed as a point phenomenon. GIS based analytical tools are used here to assess spatial dynamics of LST distribution over different Urban Built Forms. We have carried out an analysis at two levels: (i) Surface level (ii) Built geometry analysis at 3D level. The processing of indices and the generation of DEM is carried out using high resolution satellite images and Geospatial analytics. Open source, Landsat 8 OLI/TIRS+ from the United States Geological Survey (USGS) is used for computing land surface indices. High resolution satellite images, viz. stereo pair of Carstosat-1 was procured from National Remote Sensing Centre (NRSC) for the DSM creation. The processing and computation of various indices were done using Arc GIS 10.2.1, Arc Globe 10.2.1 and ERDAS LPS 9.2. Spatial analytical tools of ESRI Arc GIS 10.2.1 was used to create LST profiles of the 'S' ward and to identify areas of heterogeneity of surface temperatures.

### 3.2 Study Parameters

The study's hypothesis is that the variation in LST is a function of both 'Surface cover' and 'Built form' types as depicted in equation (1) given below. The Surface cover indices include

Normalised Differential Built Index (NDBI) and Normalised Differential Vegetative Index (NDVI) and the built form type is assessed using 'Average Built Height' and a Sky View Factor (SVF). The 'S' ward is divided into a 250m X 250m grid as a unit of analysis. All the above indices are independently analysed with respect to LST to understand their linkages.

$$\text{LST} = f(\text{surface cover, built structure}) \quad (1)$$

### 3.2.1 Land Surface Temperatures (LST)

Land Surface Temperatures (LST) can be calculated from satellite images using a digital image processing software. LST of Mumbai was computed using Optical Land Imager (OLI) with a resolution of 30m and Thermal Infrared Sensor (TIR) data with a resolution of 100m of the year 2015. Two adjacent thermal bands are the newest thermal infrared sensor which is beneficial for the LST inversion using Split Window Algorithm [10]. Split window algorithm estimates brightness temperature of the surface using spectral radiance and emissivity that is derived from Landsat 8. The spectral radiance was estimated using TIR bands 10 and 11. Emissivity was derived with the help of NDVI threshold technique for which OLI bands 2, 3, 4 and 5 were used. As the SW algorithm uses both the TIR bands and OLI bands, the LST generated using them were more reliable and accurate [11].

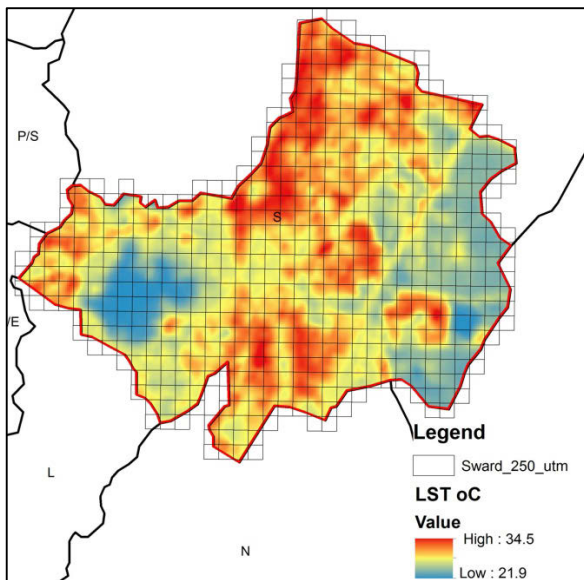

Fig. 2: Land Surface Temperature as estimated from Landsat 8 OLI/TIRS Feb, 2015 image.

### 3.2.2 Normalised Differential Built up Index (NDBI)

To extract and analyse the total built up area in an urban area, NDBI is a useful and accurate way of automatic mapping.

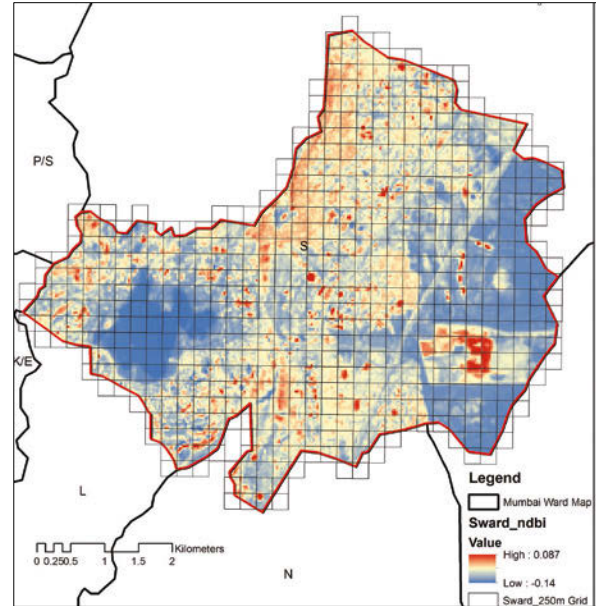

Fig. 3: Normalised Built Index of 'S' Ward clipped from Mumbai NDBI.

$$\text{NDBI} = (\text{SWIR}-\text{NIR}) / (\text{SWIR}+\text{NIR}) \quad (2)$$

Where, SWIR and NIR represent Short Wavelength Infrared Radiometer and Near Infrared band of the spectrum i.e. band 6 (1.57 – 1.65  $\mu\text{m}$ ) and band 5 (0.85-0.88  $\mu\text{m}$ ) of Landsat 8 OLI/TIRS. A high value of NDBI shows high built up area.

### 3.2.3 Normalised Differential Vegetative Index

Normalised Differential Vegetative Index (NDVI) gives the amount of vegetation on the land surface ranging from -1 to +1. A high value of NDVI denotes higher vegetation [12].

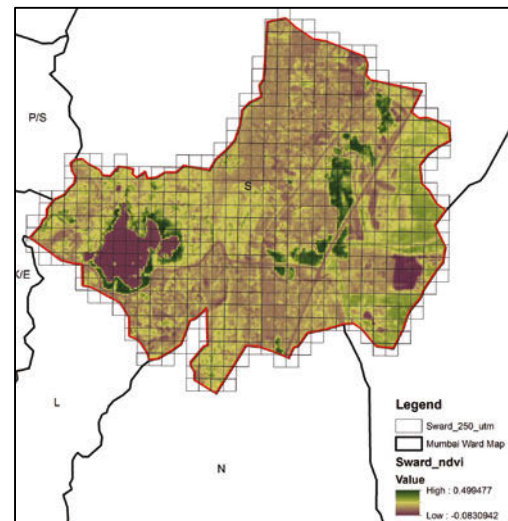

Fig. 4: NDVI map of S ward as obtained by Landsat 8, Feb 2015.

NDVI is calculated using BAND 4 and Band 5 of the Landsat 8 OLI/TIRS image as follows:

$$\text{NDVI} = (\text{NIR}-\text{RED}) / (\text{NIR}+\text{RED}) \quad (3)$$

Where, RED and NIR represent band 4 (0.64-0.67  $\mu\text{m}$ ) and band 5 (0.85-0.88  $\mu\text{m}$ ) of Landsat 8 OLI/TIRS+.

### 3.2.4 Building Height

Building height is an important variable to test the impact of roughness on land surface temperatures. Land surface properties along with the increase in building surfaces due to heights, lead to an attenuation of urban heating. The height information of each building is extracted from DSM created from CARTOSAT 2011 image. DSM was created in ERDAS Imagine LPS and then by using a building footprint, building heights were extracted in Arc GIS 10.2.1 using spatial analysis tools.

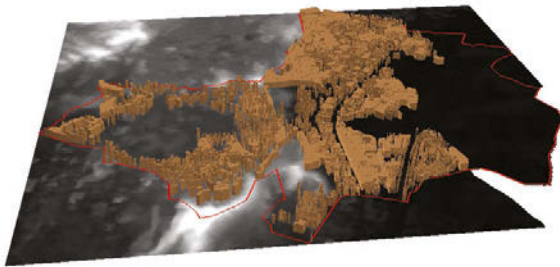

Fig. 5: Building heights extracted from DSM.

### 3.2.5 Sky View Factor

In recent urban form studies, Sky view Factor (SVF) is considered as an important parameter to ascertain built geometry and its effect on local climate as it provides useful input on the amount of radiation received and the change in emissivity caused by multiple scattering [13]. 11 grids of the ward (of 250m x 250m) were selected for computing the SVF. Selected grids cover different clusters of built form types (see figure 6).

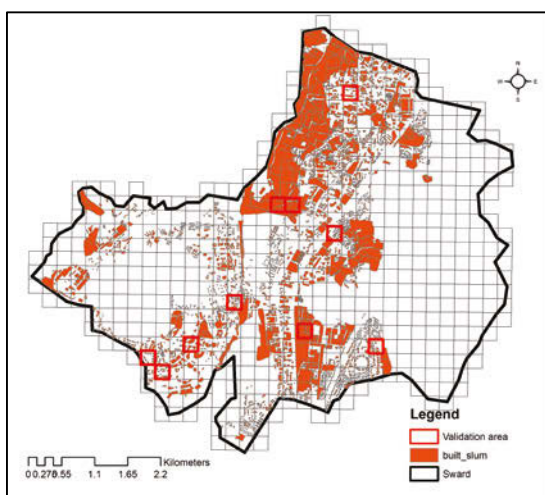

Fig. 6: Selected grids for computing SVF.

## 4 MODELS AND RESULTS

The first part of the study undertakes the regression analysis of land surface cover using both NDVI and NDBI indices (see Figure.7). Secondly, to understand the relationship between Built Form and LST, we have analysed the relation of LST with average Built Heights and SVF index for the study area. A correlation between LST and NDBI was found to be significant (C.I. 95%). The regression line plot shows positive correlation with  $R^2 = 0.64$ . The regression line plot between LST and NDVI was also correlated but with a negative slope with a correlation coefficient of  $R^2 = 0.5$  (C.I. 95%). The number of samples is 602.

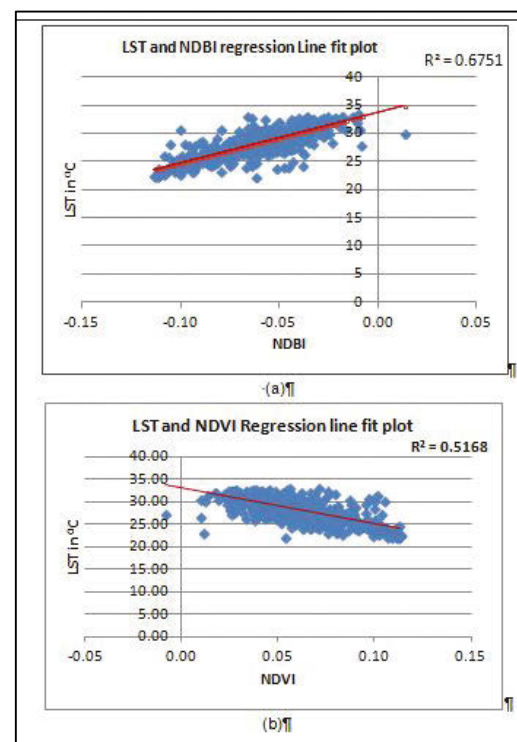

Fig. 7: Above figures show a grid wise regression line plot between (a) LST and NDBI (b) LST and NDVI for each grid of 'S' ward.

Furthermore, in order to understand the correlation of LST with building heights and form, a regression model was run between LST and average built-up heights for each grid. It was found that the average built height does not show a significant correlation with the LST. A built height analysis along with other built parameters may indicate a certain coherence. The SVF value indicates a three dimensional built geometry of the urban form, and was therefore assessed for its relation with LST. SVF was computed for the selected grids of the built form and analysed with respect to LST of the grid (refer Table 1).

S.No	BFT	SVF (mean of below mean)	LST (°C)
1	High Rise,	0.31	27.3
2	Low density,	0.38	28.9
3	High NDVI	0.24	24.2
4	Low Rise,	0.48	28.5
5	Low density,	0.38	29.1
6	Low NDVI	0.42	26.6
7	Low rise,	0.30	32.1
8	High density,	0.26	34.4
9	Low NDVI	0.32	29.3
10	High rise,	0.35	32.2
11	High density, low NDVI	0.42	28.8

Table 1: SVF and LST values for the selected grids of 'S' ward.

The relation between SVF and LST for 11 grids of the 'S' ward is given above in the Table 1. Results from the above show the relationship between SVF and LST as a linear positive coherence. An exception is observed in highly dense low rise built areas where SVF is low but have high LST.

## 5 DISCUSSIONS

Results from the regression model between Built up Index with LST imply that the high built-up area percentage in the 250 x 250 m<sup>2</sup> grids corresponds to high surface temperatures i.e. above 28°C. This can be attributed to an increased built surface area that causes multiple scatterings and trappings of incident short and long waves that increase surface temperatures of the area. Regression analyses between NDVI Index and LST for each grid show that grids having a high NDVI index correlate with low LST, which confirms that the vegetation reduces the heating of the urban surfaces by transpiration thus reducing the temperature of the neighbourhood by a considerable amount. Green cover is a significant determinant of LST and therefore should be part of urban policy guidelines.

Average built heights do not show a significant relation with LST. This can be explained by the reason that only built height may not be a significant factor to assess LST, although when analysed along with other built parameters like SVF and density, it shows a coherence with LST. In grids where the average Built Height value is high and SVF is low, day time thermal image analysis shows a low value of LST. This could be explained by the low SVF; there is mutual shading of surfaces and also has presence of high percentage of vegetation or NDVI value. This implies that we can reduce the heating of

surfaces with an adequate SVF and vegetation between built structures. Exceptions to the above phenomenon were observed in low rise, highly dense built forms, where SVF is very low, but LST was found to be very high. (refer to Table 1). This is commonly found in slum areas of the ward, where due to low SVF, there are multiple radiations that result in high LST of the area. These grids also show a high Built up and a low NDVI index.

The above analysis infers that for understanding the thermal comfort of an urban area, we must consider both surface cover properties along with built structure types. The relationship between built form and LST can be helpful in formulating future urban form policy guidelines for Mumbai and similar cities.

## 6 CONCLUSIONS

Although it is complex to establish a relationship between urban form and LST due to multifaceted variability in an urban ecosystem, this study has attempted to critically analyse the impact of urban surfaces and built form geometry on LST.

It was found that a spatial variance of LST can be analysed using geo-spatial analytics. By using the output of thermal image derived LST, we could clearly show heterogeneity of LST across the study area and find correlations with the varying built form types. Another finding from the study is that the building density and geometry is a more significant factor than the building heights while assessing the impact on LST.

In future, the work would incorporate the tree canopy cover for the SVF analysis along with wind pattern simulations combined with other built form parameters like aspect ratio and facade density to understand the Built form and LST relationship in a more intrinsic way. This is a critical area which should be addressed, especially for cities like Mumbai where cooling demand is continuously increasing with higher urbanization rates.

## 7 REFERENCES

1. A. Matzarakis and O. Matuschek, "Estimation of Sky View Factor in urban environments," *Mettoolsvii*, no. September, pp. 1–8, 2009.
2. T. R. Oke, "The energetic basis of the urban heat island," *Q. J. R. Meteorol. Soc.*, vol. 108, no. 455, pp. 1–24, 1982.
3. M. K. Svensson, "Sky view factor analysis – implications for urban air temperature differences," *Meteorol. Appl.*, vol. 11, no. 3, pp. 201–211, 2004.
4. J. a. Voogt and T. R. Oke, "Complete Urban Surface Temperatures," *J. Appl. Meteorol.*, vol. 36, no. 9, pp. 1117–1132, 1997.

5. J. . Voogt and T. . Oke, "Thermal remote sensing of urban climates," *Remote Sens. Environ.*, vol. 86, no. 3, pp. 370–384, 2003.
6. C. S. B. Grimmond, M. Roth, T. R. Oke, Y. C. Au, M. Best, R. Betts, G. Carmichael, H. Cleugh, W. Dabberdt, R. Emmanuel, E. Freitas, K. Fortuniak, S. Hanna, P. Klein, L. S. Kalkstein, C. H. Liu, A. Nickson, D. Pearlmutter, D. Sailor, and J. Voogt, "Climate and more sustainable cities: Climate information for improved planning and management of cities (Producers/Capabilities Perspective)," *Procedia Environ. Sci.*, vol. 1, no. 1, pp. 247–274, 2010.
7. L. C. L. de Souza, "Thermal environment as a parameter for urban planning," *Energy Sustain. Dev.*, vol. 11, no. 4, pp. 44–53, 2007.
8. C. S. B. Grimmond, S. K. Potter, H. N. Zutter, and C. Souch, "Rapid methods to estimate sky-view factors applied to urban areas," *Int. J. Climatol.*, vol. 21, no. 7, pp. 903–913, 2001.
9. T. P. Lin, K. T. Tsai, R. L. Hwang, and A. Matzarakis, "Quantification of the effect of thermal indices and sky view factor on park attendance," *Landsc. Urban Plan.*, vol. 107, no. 2, pp. 137–146, 2012.
10. X. Yu, X. Guo, and Z. Wu, "Land Surface Temperature Retrieval from Landsat 8 TIRS—Comparison between Radiative Transfer Equation-Based Method, Split Window Algorithm and Single Channel Method," *Remote Sens.*, pp. 9829–9852, 2014.
11. A. Rajeshwari and N. D. Mani, "Estimation of Land Surface Temperature of Dindigul District Using Landsat 8 Data," *Int. J. Res. Eng. Technol.*, vol. 03, no. 05, pp. 122–126, 2014.
12. A. A. Van De Griend and M. Owe, "On the relationship between thermal emissivity and the normalized difference vegetation index for natural surfaces," *Int. J. Remote Sens.*, vol. 14, no. 6, pp. 1119–1131, 1993.
13. J. Yang, M. S. Wong, M. Menenti, and J. Nichol, "Modeling the effective emissivity of the urban canopy using sky view factor," *ISPRS J. Photogramm. Remote Sens.*, vol. 105, pp. 211–219, 2015.



## Expanding Boundaries: Systems Thinking for the Built Environment

### INTEGRATION OF OUTDOOR HUMAN COMFORT IN A BUILDING ENERGY SIMULATION DATABASE USING CITYGML ENERGY ADE

S. Coccolo<sup>1\*</sup>, D. Mauree<sup>1</sup>, J. Kämpf<sup>1,2</sup>, J.-L. Scartezzini<sup>1</sup>

<sup>1</sup> Solar Energy and Building Physics Laboratory, EPFL-ENAC-IIC-LESO-PB, Station 18  
CH-1015 Lausanne, Switzerland

<sup>2</sup> kaemco LLC, La Riaz 6, 1426 Corcelles-Concise, Switzerland

\*Corresponding author; e-mail: [silvia.coccolo@epfl.ch](mailto:silvia.coccolo@epfl.ch)

#### Abstract

Handling data needed by Building Energy Simulation (BES) tools can be a tedious task, especially at the urban scale. Besides BES, users often have different needs (building energy use, human comfort, integration of renewables, urban planning...) in mind when using simulation tools, but often have access to the same dataset. To simplify and harmonize the process of obtaining a homogeneous dataset, we make use of a PostgreSQL database in the CityGML file format using the Energy Application Domain Extension (ADE), which can be accessed remotely to retrieve data. CityGML with Energy ADE is an open data model with the objective of having a common platform to store and exchange 3D information and energy data between municipalities, professionals and researchers. The structure of the CityGML covers the following modules: geometry, construction, occupancy and energy systems. However, in the CityGML structure an important parameter to describe the city livability is missing: the outdoor human comfort. Considering this, we propose to further develop the database, by adding outdoor human comfort parameters and results. A case study of the Ecole Polytechnique Fédérale de Lausanne (EPFL) campus will be set-up, stored in the database and simulated with the software CitySim. The resulting human comfort indices will further be sent back to the improved database for an offline analysis with GIS tools. With this new development, the CityGML with Energy ADE can benefit from information on the urban microclimate and its impact on people activities and wellbeing.

#### Keywords:

CityGML; Outdoor Human Comfort; Urban energy and sustainability; PostgreSQL

## 1 INTRODUCTION

The outdoor human comfort and the energy demand of buildings are essential parameters to quantify the sustainability and livability of a city. Sustainable development should work at several scales, creating a dynamic interaction between pedestrians, buildings and the whole city.

When focusing on City Energy Modelling, unlike Building Energy Modelling, each urban simulation engine generally has its own tailor-made data model, and there is nowadays no way of communication between these models. To address this issue, since May 2014, an international consortium of urban energy simulation developers and users (11 European

organisations (Hochschule für Technik Stuttgart, Technische Universität München, Karlsruhe Institute Technology, RWTH Aachen University, HafenCityUniversität Hamburg, European Institute for Energy Research, Ecole Polytechnique Fédérale de Lausanne, Centre Scientifique et Technique du Batiment, Electricité de France, Sinergis, M.O.S.S Computer Grafil Systeme) representing 5 urban energy platform developments ( CitySim, SimStadt, Energy Atlas, Modelica library AixLib, Sunshine platform)) is establishing an Urban Energy Information standard, as Application Domain Extension (ADE) of the CityGML urban information model. CityGML is a XML-based open data model for the

storage and exchange of virtual 3D city models, issued by the Open Geospatial Consortium (OGC) [1]. CityGML is organized around a CityGML core model, prolonged by Application Domain Extensions (ADE) for different purposes such as: geometry, construction, occupancy and energy systems. However, these modules do not address one important part of the livability in cities: the outdoor human comfort.

The human comfort, defined as the condition of mind which expresses satisfaction with the thermal environment [2], can be used as an indicator to quantify the urban microclimate, and provide guidelines for a sustainable urban development. The main meteorological parameters that affect the outdoor human comfort are: the air temperature, the wind speed, the solar irradiation, the relative humidity and the mean radiant temperature. The Mean Radiant Temperature (MRT) describes the heat radiation exchange between the human body and its environment, and it is defined as “the uniform surface temperature of an imaginary black enclosure in which an occupant would exchange the same amount of radiant heat as in the actual non uniform space” [2]. The MRT is used to quantify the outdoor human comfort: it is an input parameter in the calculation of the Physiological Equivalent Temperature (PET) [3] and the Predicted Mean Vote (PMV) [4], and is directly used to analyse the outdoor microclimate. The MRT is sensitive to the urban environment, as well as on the impact of short and long wave radiation received by pedestrian.

Several softwares exist to quantify the Mean Radiant Temperature:

- ENVI-met and the post-processing tool called BioMet, also able to quantify Predicted Mean Vote (PMV), PET and UTCI (Bruse, 2014).
- RayMan model, that calculates radiation fluxes and thermo-physiologically indices, as PMV, PET, Standard Effective Temperature (SET\*) (Matzarakis et al., 2007) UTCI and Perceived Temperature (Matzarakis, 2015).
- SOLWEIG (SOLar and Long Wave Environmental Irradiance Geometry) that quantifies PET and UTCI (Lindberg, 2015).

Several case studies were already performed with the previous software [5] [6] [7], but a common platform able to store and exchange the results is missing.

To achieve this, we propose to use a PostgreSQL database to handle data on urban areas. Cities are composed of a very large number of surfaces with various and complex properties. With a database, it becomes easier to extract, share and store this big amount of information.

This paper starts with a brief introduction of the specificities of the CityGML Energy ADE standard, defines the methodology used to extract data from the PostgreSQL database and shows the methodology to create a new outdoor human comfort module (feature type) in the CityGML Energy ADE. The new feature type, in CityGML data model, is an interchange platform with the punctual calculations of the Mean Radiant Temperature obtained by the software CitySim. The case study of the EPFL campus in Lausanne is used as demonstration case study for the analysis of the Mean Radiant Temperature, which are inserted in dedicated tables in the PostgreSQL database.

## 2 MATERIALS AND METHODS

The methodology aims to present a gateway between CitySim and CityGML Energy ADE data models, by the creation of a new feature type describing the outdoor human comfort. In previous research, a gateway between CitySim data model and CityGML Energy ADE was established, using the EPFL campus in Freiburg and Lausanne (Switzerland) as case study [8] [9].

### 2.1 CityGML with Energy ADE data model

CityGML with Energy ADE is composed of the following four interrelated modules, linked to the 3D information in the CityGML core through references:

- Building, Zones and Boundaries: where the information concerning buildings geometry, thermal zones, opening and schedules are stored.
- Construction and Layers: data concerning the physical characteristics of the envelope, such as material, and their physical and optical properties (emittance, absorptance, transmittance, and reflectance).
- Occupancy Module: describes the usage of the building, the presence of occupants, and the consequently usage of facilities and appliances.
- Energy System Module: describes the energy demand, supplied by different energy systems (conversion, distribution and storage).

The four modules are completely independent of each other. They may also not be present or be linked together through references. In the following methodology, we propose to create a new feature type in the module “Energy System Module”, called Outdoor Comfort, which contains the information of Mean Radiant Temperature and Models of Comfort. The reason for the comfort feature type to be located in the Energy System Module is due to the concept that for a person to maintain the required comfort, he or she has to exchange energy with the



environment. The results of the Mean Radiant Temperature, as calculated by the software CitySim, are stored in the CityGML Energy ADE data model.

## 2.2 Mean Radiant Temperature

The calculation of the Mean Radiant Temperature in CitySim is based on the Integral Radiation Measurements [10]: a pedestrian is designed as a cylinder, with the base inscribed in a circle of 0.17 m. It is further located in the outdoor environment, positioned at a height comprised between 1.1 and 1.5 m, corresponding to the centre of gravity of a human body [11]. The geometrical and physical characteristics of the pedestrian described in the CitySim XML data model as follows:

```
<Building Name="Pedestrian1" id="52" key="p1"
Vi="0.0306780338" Simulate="true" mrt="true"
mrtEpsilon="0.97">
```

where *mrt="true"* describes if the calculation of the Mean Radiant Temperature is performed (True) or not (False); *mrtEpsilon="0.97"* is the emissivity of pedestrian, with the standard value corresponding to 0.97.

The geometrical characteristics are described hereafter:

```
<Building>
<Zone>
<Occupants ... />
<Wall...>
<V0 x="0.11" y="0.00" z="1.10"/>
<V1 x="0.17" y="0.00" z="1.10"/>
<V2 x="0.17" y="0.00" z="1.50"/>
<V3 x="0.11" y="0.00" z="1.50"/>
</Wall>
</Zone>
</Building>
```

where the vertex (V0, V1, V2 and V3) are defined per each spatial coordinates x, y and z.

## 2.3 PostgreSQL Database

PostgreSQL is an object-relational database management system developed in the past decades as open-source software. The compatibility with geographical information systems and the ability to create new tables from existing ones are some of the interesting features of Postgres [12].

The database server Postgres together with the PostGIS add-on were installed on a Linux machine at EPFL. Data such as the building physical characteristics (material types, wall types, height, dimensions...) as well as ground surfaces were inserted in a dedicated database following the requirement by the CityGML structure.

A Java program (named CitySim Database Linker) extracts the necessary data to create an input XML file for the CitySim simulation. The simulation is then performed and the results produced (energy demand, mean radiant

temperature, irradiation on buildings, etc.) can then be fed back in the database.

A geographical information system such as QGIS, can then be used to visualize the results from the database by colouring the footprint of the buildings.

## 2.4 The Case Study: EPFL campus

The main campus of the Ecole Polytechnique Fédérale de Lausanne (EPFL) is located near the Lemman Lake and the city of Lausanne; it is one of the largest universities in Switzerland, and hosts around 15.000 people (including students and professional) each day. To illustrate the previously presented methodology, a selected area of the campus was defined (Figure 1): this area is located in the Northern part of the campus and composed of six interconnected buildings (BM, BP, CM, GC, GR and LE). It presents three different types of ground covering (grass, clay soil and asphalt) and three cherry trees in the "bocce court". The Mean Radiant Temperature is punctually calculated on a grid of 10 meters, between 1.1 and 1.5 meters above the ground.

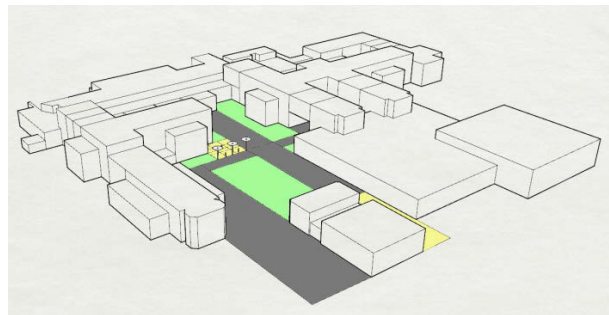

Fig. 1: Study area in the EPFL campus of Lausanne, located on the Northern part of the university. Each ground material is defined: grass (Green), asphalt (Grey) and clay soil (Yellow).

The MRT is quantified for a typical meteorological year (TMY), by the weather data provided by the software Meteororm [13] for the meteorological weather station of Pully (VD).

## 3 RESULTS AND DISCUSSION

### 3.1 CityGML with Energy ADE data model

A focus on the actual Energy System Module is shown in Figure 2, the proposed methods will relate the "ADEElement" *CityObject* with a new "featureType" called *OutdoorHumanComfort* (Figure 3). The new "featureType" *OutdoorHumanComfort* contains:

- *type: ComfortType*
- *data: TimeSeries [0..1]*
- *metabolicActivity: Measure [0..1]*
- *clothingCoefficient: Measure [0..1]*

The "enumeration" *ComfortType* contains the following methodology to analyze the outdoor human comfort: Mean Radiant Temperature, COMFA model, Index of Thermal Stress (ITS),

Physiological Equivalent Temperature (PET), Standard Effective Temperature (SET\*), Universal Thermal Climate Index (UTCI), Discomfort Index (DI), Wet Bulb Globe Temperature Index (WBGT) and Thermal Sensation.

The group *metabolicActivity:Measure* includes the pedestrian metabolic activity, expressed in  $W/m^2$ ; as an example  $58 W/m^2$  corresponds to seated, relaxed [14]. The group *clothingCoefficient*, expressed in clo, describes the clothing insulation of the studied pedestrian, as an example the clothing ensemble “Shirt, trousers, jacket, socks and shoes” corresponds to 1 clo (or  $0.155 m^2 \cdot K/W$ ).

Figure 3 shows the proposed application Schema of the EnergyADE with the new “featureType” *OutdoorHumanComfort*: the new feature type is directly related to the “ADEElement” *CityObject*, and contains the *type:ComfortType* that is readable in the green box “enumeration” *ComfortType* where the Mean Radiant Temperature and the other selected outdoor standards are defined.

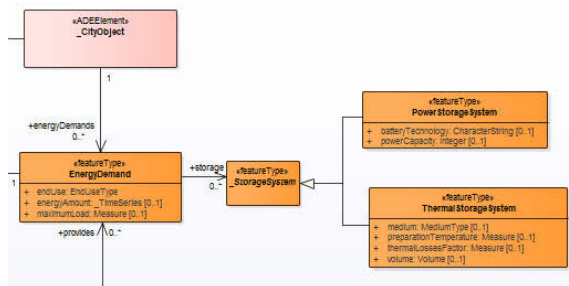

Fig. 2: Application Schema of the EnergyADE data model, detail on the Energy System. For the entire schema, please refer to [wiki.energy.sig3d.org](http://wiki.energy.sig3d.org).

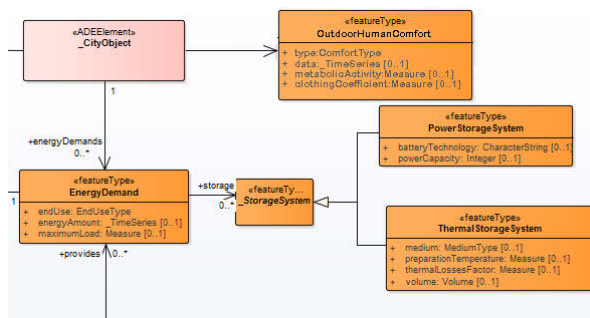

Fig. 3: Focus on the Application Schema of the EnergyADE data model, detail on the Energy System with the new feature Type Outdoor Human Comfort.

Based on the following methodology, in the CityGML data model the pedestrian is represented as a new object member called “Building” and its geometrical characteristics are described as following:

```
<cityObjectMember>
<blgd:Building>
<blgd:lod2Solid>
```

```
<gml:Solid>
<gml:exterior>
<gml:CompositeSurface>
<gml:surfaceMember>
<gml:Polygon gml:id=" b52_p_w_105">
<gml:exterior>
<gml:LinearRing>
<gml:posList>
0.11 0.00 1.10
0.17 0.00 1.10
0.17 0.00 1.50
0.11 0.00 1.50
0.11 0.00 1.10
</gml:posList>
</gml:LinearRing>
</gml:exterior>
</gml:Polygon gml:id="b52_p_w_105">
</gml:surfaceMember>
</gml:CompositeSurface>
</gml:exterior>
</gml:Solid>
</blgd:lod2Solid>
</blgd:Building>
</cityObjectMember>
```

### 3.2 Mean Radiant Temperature

The Mean Radiant Temperature calculated by CitySim will be defined as follows in the CityGML data model:

```
<energy:OutdoorHumanComfort>
<energy:ComfortType>MeanRadiantTemperature
</energy:ComfortType>
<energy:Data>
<energy:RegularTimeSeries>
<energy:id>1</energy:id>
<energy:temporalExtent>TMY</energy:temporal
nterval>
<energy:timeIntervalunit="hour">1</energy:timeI
nterval>
<energy:values uom="°C">10 10 11 15 15 16 18
20 22 22...>
</energy:values>
</energy:RegularTimeSeries>
</energy:Data >
</energy:OutdoorHumanComfort>
```

In the previous method, the MRT values are calculated for each hour of a Typical Meteorological Year (TMY).

### 3.3 PostgreSQL Database

Finally, once all the information is calculated, the data can be used to populate the corresponding table in the database. An additional table relating to the MRT was added (Figure 4).

Since the pedestrian is described as a building (Sect. 3.1), the mean radiant temperature calculated for this individual corresponds to the same “object” identified with *building\_id* and hence also relates to the building table.

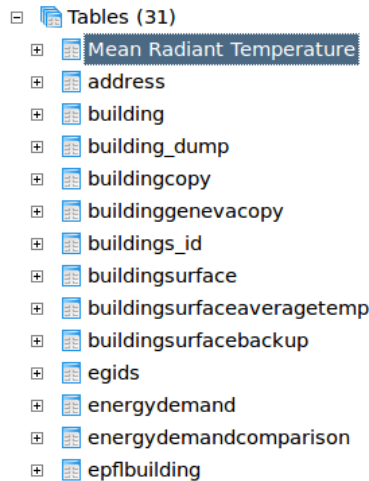

Fig. 4: Structure of the database with Mean Radiant Temperature.

### 3.4 The Case Study: EPFL campus

The Mean Radiant Temperature in a selected area of the EPFL campus in Lausanne was defined, showing its variation by the urban environment during the different periods of the year. The Mean Radiant Temperature is influenced by the built environment (shadowing provided by the neighbouring buildings, according to their orientation), by the soil covering (clay soil, grass and asphalt) and by trees. Figure 5 shows the Mean Radiant Temperature in three different locations of the site:

- A, Clay soil, with SVF=0.66.
- B, Soil covered by asphalt, under the Cherry Tree, with SVF=0.85.
- C, Soil covered by asphalt, with SVF=0.94.

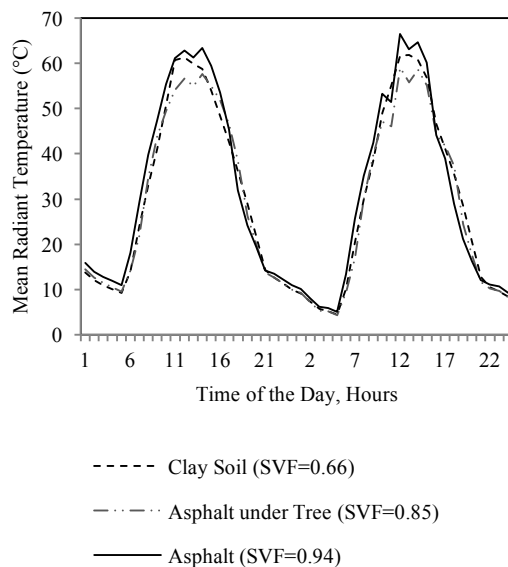

Fig. 5: Mean Radiant Temperature for two summer days, 21<sup>st</sup> and 22<sup>nd</sup> June, defined in three different positions of the site.

The highest MRT is for a pedestrian located on the asphalt, and with low shadowing protections; on the contrary the lowest MRT is defined for a pedestrian located under the cherry tree: this is related to the vegetation, which by the evapotranspiration maintains a lower temperature compared to artificial surfaces, and it reduces the short and long wave radiation received by the pedestrian. During the night time, the MRT is similar in all locations (and slightly lower than the air temperature) showing the high impact of the solar irradiation on the calculation of the MRT.

## 4 CONCLUSIONS

The presented methodology makes use of the CityGML data model to store and share simulations results concerning the outdoor human comfort; in this paper a methodology to include the Mean Radiant Temperature in the CityGML data model was defined. The Mean Radiant Temperature in a selected area of the EPFL campus was calculated, showing the impact of the built environment and the ground covering in the MRT variation during the year. Information on the case study (the EPFL campus in Lausanne) was added to a PostgreSQL database installed on a server at EPFL. A Java program was then used to extract information from this database to build a model of the campus containing the required information to perform a simulation with CitySim.

This paper presented the first steps to include the outdoor human comfort in the CityGML data model, the next steps of the project will include:

- The ability to store and share the output data provided by the following standards: COMFA model, Index of Thermal Stress (ITS), Physiological Equivalent Temperature (PET), Standard Effective Temperature (SET\*), Universal Thermal Climate Index (UTCI), Discomfort Index (DI), Wet Bulb Globe Temperature Index (WBGT) and Thermal Sensation.
- The capacity to store the output data provided by the following software: ENVI-met, RayMan and SOLWEIG.

## 5 ACKNOWLEDGMENTS

The authors wish to thank the EPFL Middle East for the financial and scientific support, as well as the Commission for Technology and Innovation of the Swiss Confederation for the funding of the Swiss Competence Centre for Energy Research, Future Energy Efficiency Buildings and Districts (FEED&D).

## 6 REFERENCES

1. G. Gröger, T.H. Kolbe, C. Nagel, K.-H. Häfele, Open Geospatial Consortium OGC City Geography Markup Language ( CityGML ) Encoding Standard, (2012).
2. ASHRAE, Thermal environment conditions for human occupancy. ANSI/ASHRAE Standards 55-2010, (2010).
3. P. Höppe, The physiological equivalent temperature - a universal index for the biometeorological assessment of the thermal environment., *Int. J. Biometeorol.* 43 (1999) 71–5.
4. P.O. Fanger, Thermal comfort. Analysis and applications in environmental engineering, 1970.
5. F. Ali-Toudert, H. Mayer, Numerical study on the effects of aspect ratio and orientation of an urban street canyon on outdoor thermal comfort in hot and dry climate, *Build. Environ.* 41 (2006) 94–108.
6. M.H. Elnabawi, N. Hamza, S. Dudek, Use and evaluation of the ENVI-met model for two different urban forms in Cairo, Egypt: Measurements and model simulations, In: 13th Conf. Int. Build. Perform. Simul. Assoc., 2013: pp. 2800–2806.
7. K.K.-L. Lau, C. Ren, J. Ho, E. Ng, Numerical modelling of mean radiant temperature in high-density sub-tropical urban environment, *Energy Build.* (2015).
8. S. Coccolo, J. Kaempf, Urban energy simulation of the EPFL Campus in Fribourg using a new paradigm: the CITYGML Application Domain Extension Energy, In: CISBAT 2015, 2015: pp. 907–912.
9. S. Coccolo, D. Mauree, J. Kaempf, Urban Energy Simulation based on a new data model paradigm: the CityGML application domain extension energy. A case study in the EPFL campus of Lausanne, In: *Build. Simul. Conf.*, 2015.
10. P. Höppe, A new procedure to determine the mean radiant temperature outdoors, *Wetter Und Leb.* 44 (1992) 147–151.
11. International Organization for Standardisation, ISO 7726. Ergonomics of the thermal environment. Instruments for measuring physical quantities, (1998).
12. B. Momjian, PostgreSQL: Introduction and concepts, Addison-We, New-York, 2002.
13. C.- Bern, J. Remund, S. Müller, S. Kunz, Meteorom. Global meteorological database. Version 7, (2013) 55.
14. International Organization for Standardisation, ISO 7730. Ergonomics of the thermal environment, (2006) 62.



## Expanding Boundaries: Systems Thinking for the Built Environment

### MULTI-SCALE MODELLING TO ASSESS HUMAN COMFORT IN URBAN CANYONS

D. Mauree<sup>1</sup>, S. Coccolo<sup>1\*</sup>, J. Kämpf<sup>1,2</sup>, J-L. Scartezzini<sup>1</sup>

<sup>1</sup>Ecole Polytechnique Fédérale de Lausanne, Solar Energy and Building Physics  
Laboratory, Station 18, CH-1015 Lausanne, Switzerland

<sup>2</sup>kaemco LLC, Corcelles-Concise, Switzerland

\*Corresponding author; e-mail: [silvia.coccolo@epfl.ch](mailto:silvia.coccolo@epfl.ch)

#### Abstract

As the impact of climate change progresses, heat waves are expected to increase significantly in the future. Coupled with the urban heat island effect, this will tend to have a major impact on the comfort of the inhabitants in urban areas. It is thus crucial to adopt the necessary sustainable measures and development scenarios to improve city liveability and human health. The main physical parameters that affect the outdoor human comfort are the air temperature, the relative humidity and the wind speed. Various tools, such as CFD or LES models, have been used in the past to evaluate these variables for the calculation of human comfort indices. These tools however are computationally too expensive and require extensive resources and data. Moreover, in our previous studies on the outdoor human comfort realized with the CitySim software, the meteorological variables were not linked to the urban form, geometry and roughness.

To overcome these barriers, the CIM (Canopy Interface Model) was developed to calculate high-resolution vertical profiles of meteorological variables. The CitySim software to perform energy and temperature simulations then used these outputs. In this study, virtual pedestrians were located in two different areas of the EPFL campus, in Lausanne (Switzerland): a natural environment - characterized by clay soil and cherry trees - and an artificial environment, the new asphalt square near the SwissTech Convention Centre. The analysis carried out with the CitySim software compares the outdoor human comfort of pedestrian with the wind data from the traditional Meteororm dataset, and the new CIM wind simulations. A sensitivity analysis of the results shows the difference between both simulations, quantifying the impact of the new wind model in the calculation of the indices.

#### Keywords:

Multi-scale modelling, human comfort, urban planning, urban microclimate

## 1 INTRODUCTION

The current observed rise in global air temperatures will also have a significant impact on human health. The IPCC [1] pointed out in their last report that it is extremely likely that heat waves will increase in the future. Heat waves have been associated with heat strokes, hyperthermia and increased mortality rate especially among vulnerable population. The 2003 heat wave in France is an example of the dramatic consequences [2,3]. Besides, the urban areas are even more at risk as they are already subject to

higher temperatures due to the urban heat island phenomena [4,5]. This is due to the absorption of solar radiation by the increased number of surfaces, the trapping of heat in urban canyons and the modification of wind patterns. The urban environment affects the outdoor human comfort, showing the impact of the urban form in the human thermal perception [6]. Different software exists to analyse the outdoor human comfort, for example ENVI-met, SOLWEIG and RayMan, and are able to quantify pedestrian thermal perception within the city environment.

Several models and parameterizations schemes have been developed in the past to represent the effect of urban areas. CFD or LES models have been used but they are computationally expensive. Recently a Canopy Interface Model (CIM) [7] has been developed and coupled with the CitySim software [8,9].

A previous case study was performed to propose a new methodology to quantify the outdoor human comfort in the built environment, with the COMFA\* thermal budget, by the use of the software CitySim [10]. For the purpose of this study, we improved the previous case study, by using the Canopy Interface Model to analyse the wind speed at 1.5 meters of height, in selected built environments. The proposed paper shows the impact of the wind speed on the outdoor human comfort, by evaluating the pertinence of using the traditional data or with the specifically calculated data.

The paper first briefly describes the computation of the wind using the CIM and the outdoor human comfort by the COMFA\* thermal budget. The experimental setup is given in Sect. 3; the results are then presented and discussed in Sect. 4. We finally conclude and give a few future perspectives for this study in Sect. 5.

## 2 METHODOLOGY

### 2.1 Wind profile by the Canopy Interface Model

A one-dimensional Canopy Interface Model was recently developed [7] to improve the surface representation in mesoscale meteorological models and to also prepare the coupling with microscale models.

CIM uses a diffusion equation derived from the Navier-Stokes equations but reduced in one direction only. EQUATION 1 is used to calculate the wind speed in both directions (we only show the equation for the  $x$ -direction).

$$\frac{\partial U}{\partial t} = \frac{\partial}{\partial z} \left( \mu_t \frac{\partial U}{\partial z} \right) + f_u^s \quad (1)$$

where  $U$  is the horizontal wind speed in either the  $x$ - or  $y$ -direction,  $\mu_t$  is the momentum turbulent diffusion coefficient and  $f_u^s$  is the source term representing the fluxes (from the surface or buildings) that will impact the flow.

The momentum diffusion coefficient is calculated using:

$$\mu_t = C_\mu \sqrt{E} l \quad (2)$$

where  $C_\mu$  is a constant equal to 0.3 and  $E$  is the turbulent kinetic energy (TKE).  $l$  is defined as the mixing length and is taken from [11] and adapted by [7] to account for the obstacles density and varying building height in the canopy.

The boundary conditions at the top of CIM is forced using an extrapolated value from the Meteorom meteorological dataset. The ground surface temperature calculated by CitySim [12] is used as an input for the CIM model. The wind profile is calculated along the vertical axis in both  $u$  and  $v$  directions in each cell with a resolution of 3m. The wind speed computed at 1.5 m above the ground will then be used as an input parameter in CitySim to quantify the outdoor human comfort, by the COMFA\* budget.

### 2.2 Outdoor human comfort

The outdoor human comfort is analysed by the COMfort Formula (COMFA\* Budget) and is expressed in  $W \cdot m^{-2}$ . The fundamental equation that describes COMFA\* model [13] is:

$$B = M + R_{RT} - C - E - L \quad (3)$$

where  $M$  is the metabolic heat generated by a person,  $R_{RT}$  are short and long wave radiations absorbed,  $C$  is the sensible heat lost by convection,  $E$  is the evaporative heat loss through perspiration and  $L$  is the long-wave radiation emitted by a person. All fluxes are expressed in ( $W \cdot m^{-2}$ ). The thermal sensation scale of COMFA Budget is defined in Table 1.

COMFA Budget ( $W \cdot m^{-2}$ )	Thermal Sensation
$\leq -201$	Cold
-200 to -121	Cool
-120 to -51	Slightly cool
-50 to +50	Comfort
+51 to +120	Slightly warm
+121 to +200	Warm
$\geq +201$	Hot

Table 1: COMFA budget ( $W \cdot m^{-2}$ ) as function of thermal sensation.

Pedestrian are modelled with the software CitySim, further details concerning the methodology are available in a previous case study [10].

## 3 EXPERIMENTAL SETUP

The outdoor human comfort is calculated on two selected areas of the EPFL campus: the new square near the Swiss Tech Convention Centre (Case study A) and a natural environment that host a "bocce" court (Case study B); the location of the selected environments is defined in Fig. 1. The two sites are commonly used by students and workers of the university during the daytime as nice environments for discussions and relaxation.

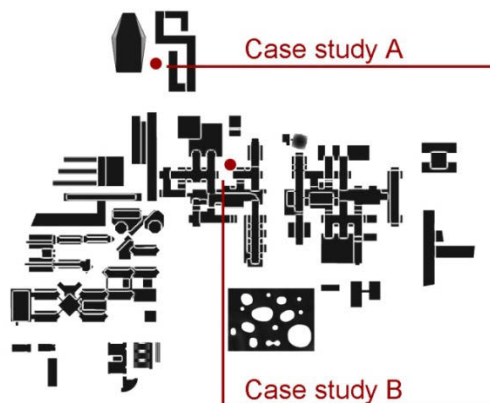

Fig. 1: EPFL campus in Lausanne, selected outdoor environment where the outdoor human comfort is defined: the new square near the Swiss Tech Convention Centre (Case study A) and a natural environment that host a “bocce” court (Case study B).

## 4 RESULTS AND DISCUSSIONS

### 4.1 Wind profile by the Canopy Interface Model

The wind profiles determined by the CIM are computed from an extrapolated value from Meteonorm. Figure 2 gives an example of three profiles for three particular days for the STCC study case. The profiles simulated with CIM (black cross) taking into account the presence of obstacles has a much lower wind speed as compared to the one coming from Meteonorm (dotted line). This is due to (i) the drag force which significantly reduces the wind speed when vertical surfaces are present in the canopy and (ii) the modification of the mixing length that was calculated based on the density and height of obstacles. The wind speeds at the top of the column do not correspond because, on the one hand, when using the Meteonorm dataset the value computed at 10m height is used over the whole column. On the other hand, when using CIM, a value is calculated for every cell (20 cells of 3m each) in the column. Above the building height (30m), the wind speed increases rapidly to reach the Meteonorm value.

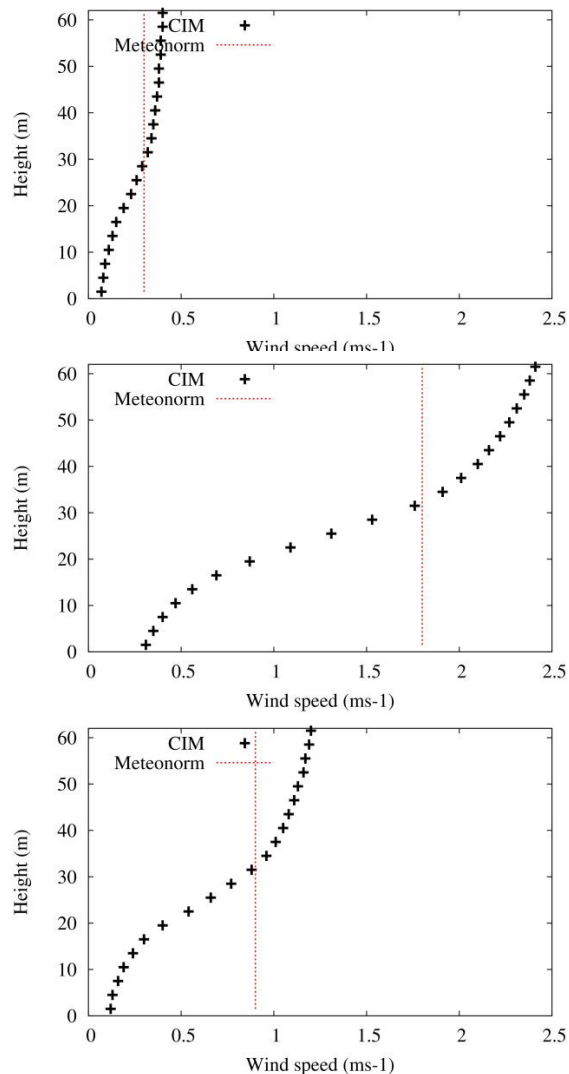

Fig. 2: Vertical profile of the wind speed (ms-1) for (from top to bottom) 21<sup>st</sup> March, 21<sup>st</sup> June and 21<sup>st</sup> of December; in dotted red – Meteonorm data; black cross – CIM profiles.

Figure 3 (a, b and c) gives a daily wind speed profile provided by Meteonorm and calculated by CIM in the square near the Swiss Tech Convention Centre, for the 21<sup>st</sup> of March, 21<sup>st</sup> of June and 21<sup>st</sup> of December and which will be used in the COMFA\* Budget. As expected the urban geometry impacts the wind speed which is reduced compared to the one provided by Meteonorm. Additionally, the wind speed provided by Meteonorm is given for a 10 m height while on the contrary the one calculated by our methodology is defined at 1.5m height, corresponding to the centre of gravity of the human body. The wind speeds are higher during the daytime and lower during the night-time, this can be explained by the turbulent fluxes that appear in contact with heated surfaces; as an example during the 21<sup>st</sup> of June the maximal wind speed during the daytime is 0.3 m/s, and lower than 0.1 m/s during the night-time.

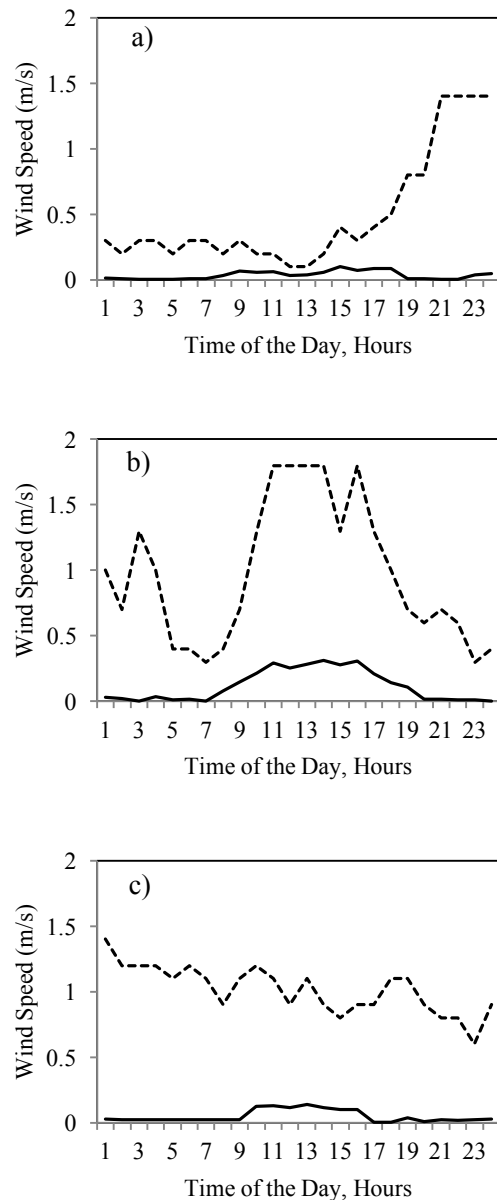

Fig. 3: Wind speed provided by the software Meteonorm (dotted line) and calculated by the Canopy Interface Model (continuous line) for the square near the Swiss Tech Convention Centre. a) 21<sup>st</sup> of March. b) 21<sup>st</sup> of June. c) 21<sup>st</sup> of December.

The wind speed (not shown here), as calculated by the CIM in the bocce court, is drastically reduced, with a yearly average speed of 0.01 m/s due to the density of the built environment.

#### 4.2 Outdoor human comfort

The outdoor human comfort was calculated with the weather data provided by the software Meteonorm and with the Canopy Interface Model. Figure 4 shows the COMFA\* Budget for the 21<sup>st</sup> of March, 21<sup>st</sup> of June and 21<sup>st</sup> of December for a pedestrian located near the Swiss Tech Convention Centre. The thermal sensation perceived by the pedestrian varies with the

weather data: the pedestrian is facing a hot thermal sensation from 12 to 17 hours, if using the weather data provided by Meteonorm. However hot thermal sensation will increase by one hour if using the CIM data model, passing from warm to hot at 11 am. This is related to the wind speed, that changes from 1.0 m/s in average during the day (with a maximal speed equal to 1.8 m/s) to an average speed of 0.1 m/s (with a maximum speed equal to 0.3 m/s). During the 21<sup>st</sup> of March there is no difference in thermal perception during the daytime, just during the night-time when the maximum difference between the wind speeds is 1.4 m/s. The difference between the two models is lower during the winter solstice, when the perceived thermal sensation is constantly lower in the CIM model during the day and night time.

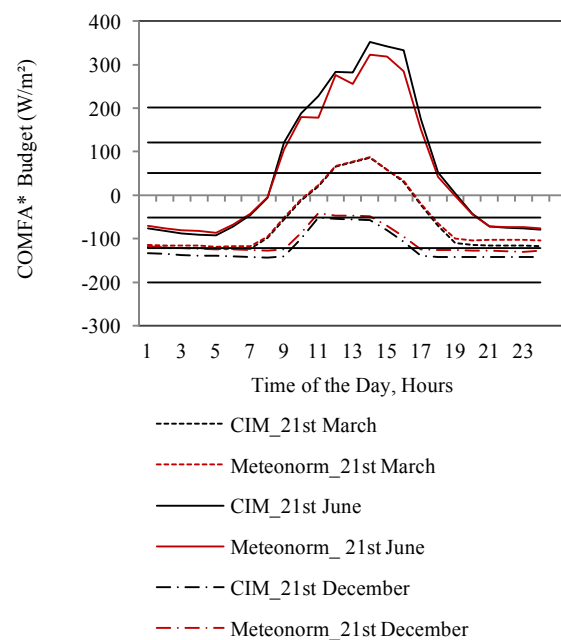

Fig. 4: COMFA\* energy budget for the square near the Swiss Tech Convention Centre, during the 21<sup>st</sup> of March, 21<sup>st</sup> of June and 21<sup>st</sup> of December. Comparison between weather data provided by Meteonorm (Red) and calculated by CIM (Black).

The outdoor human comfort calculated in the "bocce court" presents the same behaviour as in the other case study: the reduction of the wind speed in the outdoor environment affects the thermal balance of the pedestrian, by reducing the comfortable hours (see Fig. 5). In this case study, the outdoor human comfort is largely impacted during the 21<sup>st</sup> of June, when the wind speed will be drastically decreased, passing from 1 m/s in average during the daytime, to 0.01 m/s in average for the same period of the day. During the selected day, the pedestrian analysed with the weather data provided by Meteonorm will face just three hours of hot thermal sensation (from 13 to 15 hours) and a warm thermal sensation from 10 to 14 and from 16 to 17 hours. On the contrary the



same pedestrian by using the wind profile calculated by CIM, will face a hot thermal sensation from 10 in the morning to 17 in the afternoon. The parameter mostly affected by the wind speed reduction is the sensible heat lost by convection: during the 21<sup>st</sup> of June it changes from 49 W·m<sup>2</sup> (weather data provided by Meteororm) to 19 W·m<sup>2</sup> (weather data provided by CIM). By comparing the two locations in the EPFL, a pedestrian located in the square near the Swiss Tech will face during more hours a warm and hot thermal sensation, compared to the bocce court, by using the wind profile provided by Meteororm. This behaviour varies if using the CIM profile: the wind speed drastically decreases in the bocce court (because of the density of the district) and consequently the discomfort hours are higher in this location compared to the other one.

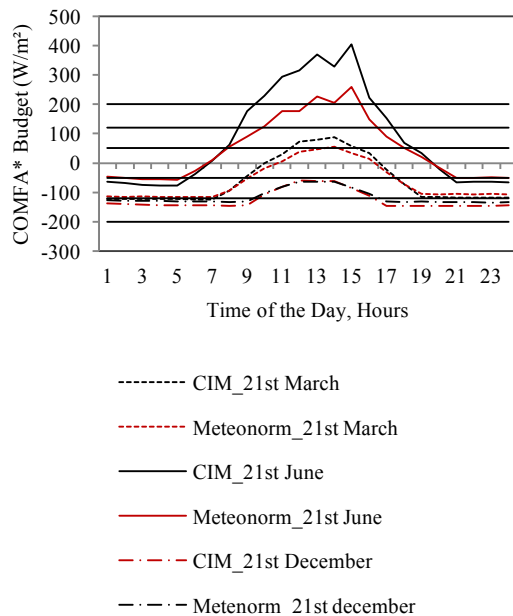

Fig. 5: COMFA\* energy budget for the bocce court, during the 21<sup>st</sup> of March, 21<sup>st</sup> of June and 21<sup>st</sup> of December. Comparison between weather data provided by Meteororm (Red) and calculated by CIM (Black).

## 5 SUMMARY AND CONCLUSION

This paper describes a new methodology to quantify the impact of the wind speed in the outdoor human comfort, by the use of the Canopy Interface Model, and the COMfort Formula. In this study, a Canopy Interface Model was used to calculate high-resolution meteorological profiles (every 3 m). The wind speed calculated at 1.5m was then used as an input for the computation of the comfort index.

It was shown that when working in an urban setup, it is necessary to take into account the impact of buildings on the wind patterns, as they are significantly influenced (for ex. a reduction of 80% for the 21<sup>st</sup> June at midday).

The COMFA\* budget varies if using the CIM wind model or the data provided by Meteororm, by varying the urban density. The example of the bocce court shows an important increase of the warm and hot thermal sensation by using the CIM wind profile, as compared to the Meteororm one. The human thermal way of exchange that varies the most is the sensible heat lost by convection, that changes from 49 W·m<sup>2</sup> (weather data provided by Meteororm) to 19 W·m<sup>2</sup> (weather data provided by CIM).

In future studies, we will also look into the impact of the thermal stratification on the temperature profiles in an urban canopy and how this can influence the COMFA\* budget.

## 6 ACKNOWLEDGMENTS

The authors wish to thank the EPFL Middle East, as well as the Commission for Technology and Innovation of the Swiss Confederation for the funding of the Swiss Competence Centre for Energy Research, Future Energy Efficiency Buildings and Districts (FEED&D).

## 7 REFERENCES

1. IPCC, *WORKING GROUP I CONTRIBUTION TO THE IPCC FIFTH ASSESSMENT REPORT CLIMATE CHANGE 2013: THE PHYSICAL SCIENCE BASIS*. Geneva: Intergovernmental Panel on Climate Change, 2013.
2. M. Poumadère, C. Mays, S. Le Mer, et R. Blong, « The 2003 Heat Wave in France: Dangerous Climate Change Here and Now », *Risk Anal.*, vol. 25, n° 6, p. 1483–1494, 2005.
3. A. Fouillet, G. Rey, F. Laurent, G. Pavillon, S. Bellec, C. Guihenneuc-Jouyau, J. Clavel, E. Jouglu, et D. Hémon, « Excess mortality related to the August 2003 heat wave in France », *Int. Arch. Occup. Environ. Health*, vol. 80, n° 1, p. 16–24, 2006.
4. T. R. Oke, « CITY SIZE AND THE URBAN », vol. 7, p. 769–779, 1973.
5. T. R. Oke, « The energetic basis of the urban heat island », *Q. J. R. Meteorological Soc.*, vol. 108, p. 1–24, 1982.
6. E. Johansson, « Influence of urban geometry on outdoor thermal comfort in a hot dry climate: A study in Fez, Morocco », *Build. Environ.*, vol. 41, n° 10, p. 1326–1338, oct. 2006.
7. D. Mauree, « Development of a multi-scale meteorological system to improve urban climate modeling », Université de Strasbourg, 2014.
8. D. Mauree, J. H. Kämpf, et J.-L. Scartezzini, « Multi-scale modelling to improve climate data for building energy models »,

présenté à 14th International Conference of the International Building Performance Simulation Association, 2015.

9. D. Mauree, N. Blond, A. Clappier, J. Kämpf, et J. Scartezzini, « Evaluation of building energy use : from the urban to the building scale », in *ICUC9 - 9th International Conference on Urban Climate jointly with 12th Symposium on the Urban Environment*, 2015.
10. S. Coccolo, J. Kämpf, et J.-L. Scartezzini, « Outdoor human comfort and climate change . A case study in the EPFL campus in Lausanne », in *ICUC9 - 9th International Conference on Urban Climate jointly with 12th Symposium on the Urban Environment*, 2015.
11. J. L. Santiago et A. Martilli, « A Dynamic Urban Canopy Parameterization for Mesoscale Models Based on Computational Fluid Dynamics Reynolds-Averaged Navier–Stokes Microscale Simulations », *Bound.-Layer Meteorol.*, vol. 137, n° 3, p. 417-439, déc. 2010.
12. D. Robinson, *Computer modelling for sustainable urban design. Physical principles, methods & applications*. 2011.
13. N. a Kenny, J. S. Warland, R. D. Brown, et T. G. Gillespie, « Part A: Assessing the performance of the COMFA outdoor thermal comfort model on subjects performing physical activity. », *Int. J. Biometeorol.*, vol. 53, n° 5, p. 415-28, sept. 2009.



## ASSESSING THE PERFORMANCE AND RESILIENCE OF FUTURE ENERGY SYSTEMS AT NEIGHBORHOOD SCALE

Jimeno A. Fonseca<sup>1,2\*</sup>, Arno Schlueter<sup>1,2</sup>

<sup>1</sup> ETH Zurich, Future Cities Laboratory, Singapore-ETH Centre, 1 Create Way, 138602, Singapore

<sup>2</sup> ETH Zurich, Chair of Architecture and Building Systems, Jon Von Neumann-Weg 9, 8093, Zürich

\*Corresponding author; e-mail: [fonseca@arch.ethz.ch](mailto:fonseca@arch.ethz.ch)

### Abstract

This study compares the performance and resilience of future energy systems at neighborhood scale. Four urban design scenarios of a neighbourhood in Switzerland are evaluated. The energy systems of each scenario are modelled in EnergyPro. EnergyPro allows simulating hourly exchanges among vectors of demand and supply in buildings and electro-mobility. The performance of energy systems is evaluated according to costs, energy and carbon intensity. The resilience of energy systems is evaluated according to short-term and long-term responses to an electricity outage. The performance and resilience of energy systems are constrained to options of energy storage and on-site generation. Similarly, these options are constrained to land-uses and patterns of consumption in buildings. This paper builds new knowledge about the impacts of plans of urban development on the performance and resilience of energy systems.

### Keywords:

Urban energy systems; life cycle assessment; resilience of power systems; sustainable development; neighbourhood scale

## 1 INTRODUCTION

In line with current targets for urban sustainability, cities need to build new knowledge about the impact of future patterns of development on the performance of energy infrastructure [1].

Most infrastructure systems in cities are highly reliant on energy systems for their operation. Mobility, water-supply, communication, healthcare, housing and banking are examples of systems highly dependent on a continuous supply of energy. This strong dependency supports concentrated efforts on building robustness and resilience of energy systems.

Vugrin et al. [2] define system's resilience as the capacity to absorb, adapt and restore its performance after affected by a disruption (e.g., electrical outage). The absorptive capacity is the degree to which a system can automatically absorb a disturbance and minimize the consequences with little effort. Concerning energy

systems, this capacity is covered by backup systems.

On the other hand, the adaptive capacity refers to a system's capability of self-organization. It involves actions that require an extra effort in time. In relation to energy systems, on-site generation plays a key role as users without access to energy are prone to look for alternatives locally.

In contrast, the restorative capacity represents the ability of the system to be repaired exogenously. In the case of energy systems, this capacity mostly involves the efficacy of maintenance systems to prevent disasters or react quickly.

Recently, [3] assessed the environmental impact of future patterns of development of a neighbourhood in the city of Zug in Switzerland by 2030. For the urban scenarios of Fig. 1, [3] depicted the influence of land uses on the performance of district-scale energy systems. The Status Quo scenario (SQ) describes today's

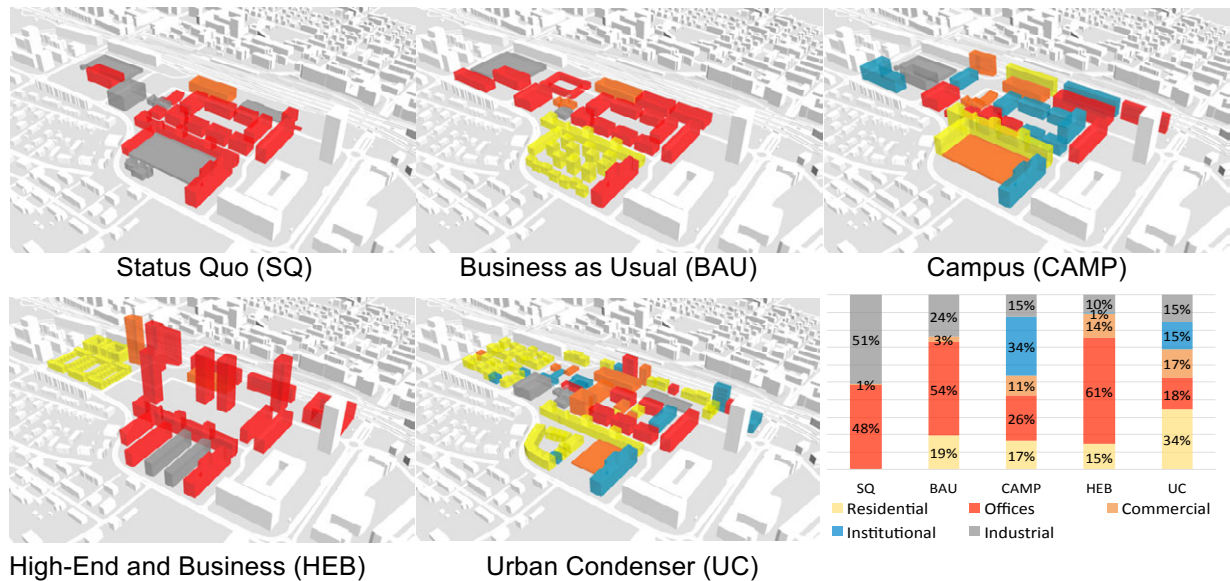

Fig. 1: Urban design scenarios. Legend: Mix of Land uses.

condition of an industrial site of 25ha. A large manufacturer in the light industry sector owns and predominately occupies the site. At the moment, there is no residential use on-site. The Business-As-Usual scenario (BAU) focuses on the industrial legacy of the site with a small expansion to residential uses. The Urban Condenser scenario (UC) presents a balanced mix of industrial, residential and commercial uses. The UC scenario is a socially-inclusive strategy to increase the livability of the area. It offers housing close to job opportunities and open spaces for leisure and recreational activities. The High-end Business scenario (HEB) drives the light industry out of the area and populates it with high-rise buildings in the services sector. This scenario responds to economic growth observed in the area. The Campus scenario (CAMP) describes a university environment with laboratories, housing, and catering services. In this area, students, residents, and workers meet with big parcels of open space, which evoke pedestrian mobility. More information of these scenarios can be found in [3]

This paper expands the approach of [3] to address how future patterns of development could influence the capacity of their energy systems to adapt and absorb a disturbance.

Section 2 describes a general methodology for such assessment. Section 2.1 and 4 present a comparison between descriptive variables of performance and resilience. Section 5 concludes.

## 2 METHOD

### 2.1 Data collection and processing

For the urban design scenarios of [3] information was collected about:

- Number of users per land use and target group (i.e., students, workers in industry,

services and institutional sectors, residents, visitors) [3]

- Transportation modes (e.g., private, public [bicycle, train, bus]) and shares per target group [3]
- Energy demand patterns (i.e., total hourly heating, cooling and electrical demand) [4]
- Optimal energy systems configurations (i.e., capacities of equipment for generation storage and distribution of energy) [1]
- Key performance indicators (KPI's) of optimal systems (i.e., greenhouse gas emissions [ $GHG$ ], non-renewable primary energy [ $PEN_{nr}$ ] (Include embodied energy and grey emissions of buildings and energy infrastructure.) and total annualized energy costs [ $TAC$ ] per unit of heated space) [1]

The electrical storage capacity of vehicle-to-grid electro-mobility (V2G) of every scenario was determined according to [5]. For this, the next assumptions were considered:

- A density of 0.30 private vehicles per resident in BAU and HEB scenarios [6]
- A density of 0.25 private vehicles per worker in SQ, BAU and HEB scenarios [6]
- A density of 0.10 private vehicles per worker/visitor/resident in CAMP and UC scenarios [6]
- An electrical storage capacity of 50 kWh/veh,
- A density of 0.05 private vehicles per student in CAMP and UC scenarios [6]
- 20% penetration of V2G in private automobile use

### 2.2 Resilience assessment.

The resilience of the energy system is calculated for a long-term electricity outage. For this, the hourly operation of the energy system of each scenario (Table 1) was simulated in EnergyPro

Property	SQ	BAU	CAMP	HEB	UC
Energy consumption (GWh/yr)					
Heating	13.5	13.2	16.7	16.9	14.3
Cooling	4.6	5.5	3.9	6.1	5.1
Electricity	17.9	22.1	15.2	24.4	16.4
Energy intensity (kWh/m <sup>2</sup> .yr)	271	237	159	188	192
Heating capacity (MW)					
NG-fired boiler	10.2	-	12.7	-	11.5
Heat pumps	-	6.8	5.2	6.2	6.5
PV-T	-	14.6	11.1	14.2	8.4
Cooling capacity (MW)					
Lake water pumps	0.3	0.4	0.3	0.5	0.4
Electrical capacity (MW)					
PV	-	0.4	-	-	-
PV-T	-	3.68	2.8	3.29	2.2
Local grid (step-down transformer)	10	15	15	15	15
Storage capacity (MWh)					
Hot thermal storage	9.3	7211	5939	7470	5309
Cold thermal storage	5.8	5.8	5.8	5.8	5.8
Backup Diesel	1.3	1.3	1.3	-	-
Electrical battery	0.5	0.5	0.5	-	-
Electro-mobility batteries	0	18.7	10.7	30	9
PV Generation (GWh)					
Generated	-	3.0	2.8	3.6	2.2
Potential available	5.8	1.6	3.9	0.8	4.2
Renewable energy (%)	11	52	39	46	38

Table 1 Characteristics of energy system configuration per scenario.

v4.1. For this, the next assumptions were considered:

- Maximum discharge rate of 50%/veh and charging/discharging capacities of 10 kW/veh (semi-fast charging cars) [7]
- Parking hours in the area between 9:00 and 18:00 during weekdays for vehicles in commercial, industrial and institutional sectors
- Parking hours between 22:00 and 9:00 during weekdays and Saturdays, and between 00:00– 24:00 during Sundays for the residential sector

Two descriptive variables of resilience were evaluated: the minimum reserve margin ( $RM_{peak}$ ) [8] and the minimum potential resource margin ( $PM$ ). The last is introduced as part of this study.  $RM_{peak}$  addresses the absorptive capacity of the energy system and represents the available power capacity at peak time (including electrical storage, backup capacities and interaction with batteries in V2G electro-mobility) as a percentage of the demand.

On the other hand,  $PM$  addresses the adaptive capacity of the system. It is equal to the ratio between the potential energy available from local resources and the non-attended portion of the electrical demand after a long-term disruption. This margin is an indicator of the alternatives that users have to change their energy supply and subsequently adapt to on-site generation over time. If the possibility of using fossil fuels is neglected for this end (with the exception of emergency systems), the unexploited solar potential is the only source included in this assessment. For scenarios with solar generation, this potential refers to the fraction of solar energy sold to the grid and that could be otherwise stored.

### 3 RESULTS

Fig. 2 presents the performance of the energy system of each scenario. In this diagram, a target area describes the Swiss benchmark for sustainable development (the 2000-Watt / 1 ton CO<sub>2</sub> Society standard) [5].

Similarly, Fig. 3 presents the resilience of the energy system of each scenario. In this diagram,

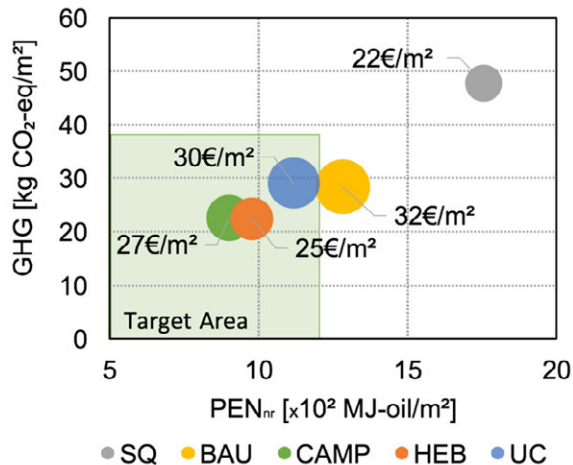

Fig. 2 The performance of energy systems. In this figure, the size of the bubble represents the TAC of each scenario.

a target area represents the minimum robustness desired for the area. These values are estimated in a  $RM_{peak} \geq 80\%$  and  $PM \geq 20\%$ .

#### 4 DISCUSSION

The performance of energy systems could increase as a consequence of three factors:

- A general decrease of the energy intensity per scenario (from -13% to -41%)
- A general increase in the penetration of renewable energy sources (from 2.4 to 3.7 times) subjected to costs between 22% to 46% higher than today
- A resulting reduction of emissions and primary energy consumption (from 40% to 57%)

In the long-term, electrical storage could contribute to increase the performance of systems as it enables higher penetrations of renewable energy.

The resilience of energy systems for the area of study could be affected both positively and negatively, especially in scenarios with more than 50% of office space (BAU and HEB).

- Positively, as a consequence of higher electrical storage capacities (from 18MWh to 30 MWh). These capacities are attributed to industry on site (backup systems) and high V2G attracted by costumers in the commercial sector.
- Negatively, by a high penetration of local resources (close to 50%) in today's energy mix. This situation could limit future opportunities for on-site generation.

#### 5 CONCLUSION

This study presented an assessment of the performance and resilience of energy systems

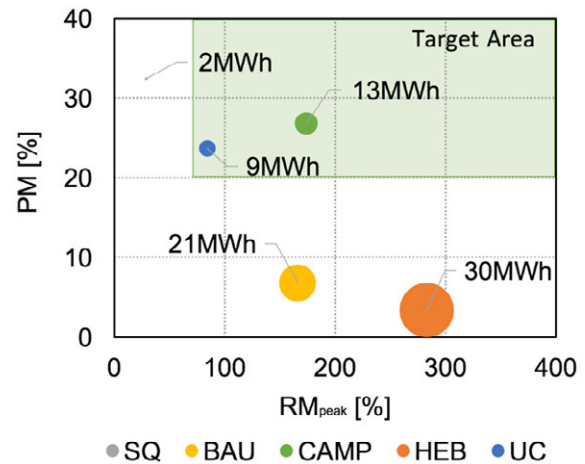

Fig. 3 The resilience of energy systems. In this figure, the size of the bubble represents the total electricity storage per scenario.

under future patterns of development at neighborhood scale.

For the case study, the performance of the energy system could increase as a result of building retrofits and on-site generation. In the long-term, electrical storage could contribute to increasing the performance of the systems.

On the other hand, the resilience of the system could be constrained to the existence of high fractions of V2G (attracted by office space), backup systems in industry and the potential for on-site generation. The last aspect is highly constrained to the building intensity of the area.

#### 6 ACKNOWLEDGMENTS

We would like to thank our colleagues of the IDEA League Doctoral School on Urban systems and Prof. Han Meyer from TU-Delft for support. We thank Zoltan Nagy for reviewing this article. This research was funded by the Swiss Commission for Technology and Innovation (CTI).

#### 7 REFERENCES

1. J. A. Fonseca, T.-A. Nguyen, A. Schlueter, and F. Marechal, "City Energy Analyst (CEA): Integrated framework for analysis and optimization of building energy systems in neighborhoods and city districts," *Energy Build.*, vol. 113, pp. 202–226, Feb. 2016.
2. E. D. E. Vugrin, D. E. DE Warren, M. a. Ehlen, and R. C. Camphouse, "A framework for assessing the resilience of infrastructure and economic systems," *Sustain. Resilient Crit. Infrastruct. Syst. Simulation, Model. Intell. Eng.*, pp. 77–116, 2010.
3. J. A. Fonseca, A. Willmann, C. Moser, M. Stauffacher, and A. Schlueter, "Assessing the environmental impact of future urban developments at neighborhood scale," in *Proceedings of CISBAT 2015*, 2015, p. 6.

4. J. A. Fonseca and A. Schlueter, "Integrated model for characterization of spatiotemporal building energy consumption patterns in neighborhoods and city districts," *Appl. Energy*, vol. 142, pp. 247–265, 2015.
5. Schweizerischer ingenieur-und architektenverein (SIA), "SIA – Mobilität – Energiebedarf in abhängigkeit vom Gebäudestandort -Merkblatt 2039." p. 40, 2011.
6. D. Jaquemet, C. Moser, and M. Stauffacher, "Siemens Building Technologies: Nachhaltigkeit und Energie-Effizienz am Standort Zug.," ETH-UNS TdLab, Zürich, 2013.
7. F. Nemry and M. Brons, "Plug-in Hybrid and Battery Electric Vehicles Market penetration scenarios of electric drive vehicles," *Jrc-Ipts*, pp. 1–36, 2010.
8. E. Ibáñez, K. Gkritza, J. McCalley, D. Aliprantis, R. Brown, A. Somani, and L. Wang, "Interdependencies between energy and transportation systems for national long term planning," *Sustain. Resilient Crit. Infrastruct. Syst. Simulation, Model. Intell. Eng.*, no. 0835989, pp. 53–76, 2010.







## Expanding Boundaries: Systems Thinking for the Built Environment

### FACILITATING CLIMATE ADAPTIVE URBAN DESIGN – DEVELOPING A SYSTEM OF PLANNING CRITERIA IN HUNGARY

F. Szkordilisz<sup>1\*</sup>, M. Kiss<sup>2</sup>, L. A. Égerházi<sup>2</sup>, D. Kassai-Szoó<sup>2</sup>, Á. Gulyás<sup>2</sup>

<sup>1</sup> Hungarian Urban Knowledge Centre, Liliom str. 48, 1094, Budapest, Hungary

<sup>2</sup> Department of Climatology and Landscape Ecology, Faculty of Science and Informatics, University of Szeged, Egyetem street 2., 6722, Szeged, Hungary

\*Corresponding author; e-mail: f.szkordilisz@mut.hu

#### Abstract

Urban microclimate has become a fashionable topic in the last decade to involve quite a few researchers. Numerous researches have proved the effectivity of urban parks, green facades and roofs in providing shade and shelter for the urban dwellers and in also having an important role in creating cool islands inside the urban heat island.

Urban planners do not dispute the mentioned principles, and they seem to have a lively interest towards climate-conscious planning, but they have to face a lack of information regarding the tools of climate adaptive urban design and their microclimatic effect. Even though the importance of climate-consciousness in urban planning has been proved, it hasn't come to the point to develop an articulate, easy-to-use planning system for architects and urban planners

Our aim is to create a system of climate-adaptive planning instruments and their impact on urban microclimate – converting the results of theoretical researches and field measurements – which could help urban planners in their everyday planning routine.

In our work we present a work-in-progress version of a targeted indicator system which can be used in urban renovation projects.

#### Keywords:

climate-adaptive urban planning; planning guidelines; urban microclimate

### 1 INTRODUCTION, LITERATURE REVIEW

Considering the dynamic growth of urban population – according to some prognoses [1] in 2050, two-thirds of the whole 10 billion population will be city-dwellers – urban related problems will be and are already the main issues of the 21st century. Besides social and economic issues, the importance of environmental, climate and energy related problems we have to face rises too. To cut down the threatening symptoms into details, the constant rising of air temperatures will have multiple effects. [2] What's more, in urban areas man-made morphology and anthropogenic heat-emission causes a significant rise in temperatures, magnifying the negative effects of climate change. This will have a drastic impact on humans' physiology, affecting not only the ones ill and elderly, but probably everybody [3]. Due to the increase in temperature and disrupted radiation conditions, the city-dwellers' behaviour in urban spaces will change too [4]. These are all problems

requiring multi-disciplinary answers, but among other experts urban planners can act in order to mitigate negative effects of climate change and urban heat island.

After delineating the main issues of spatial planning, we have to add that we do have the answers considering knowledge based on multiple research and technology. For instance, the usage of cool materials [5], with ensuring urban cross-ventilation [6] and by creating ponds, fountains, and other water surfaces in urban spaces [7], the human thermal comfort of the passers-by can be improved by a significant extent. In creating good thermal comfort outdoors [8] and indoors too, the role of urban vegetation has to be mentioned.

The mentioned tools' effectivity varies not only depending on the facilities of a public space, but also humans' perceptions differ from one another [9]. Of course the interventions, which are most likely to modify one's thermal comfort in a positive

way, should be preferred in urban design. Furthermore, planners should also take into consideration the different environmental effectiveness – such as CO<sub>2</sub>-fixation, air pollution removal [10] – of the mentioned climate-adaptation strategies.

But, what actually hinders turning the results of numerous researches into reality is that there is a lack of one integrated and complex planning system which wouldn't require special and detailed climatologic knowledge from urban planners, but would enable an easy and simple usage in everyday planning routine. Planners of course are not in the position of carrying out dozens of measurements or modelling, they are interested in using the results and data available – and indeed they are interested. In the last years a lively attraction has arisen amongst urban planners for climate-adaptive solutions in spatial planning. There have been courses conducted all over Europe and a unique success has been reported. Seeing the open-minded colleagues, our team decided to set up a system of climate-adaptive planning criteria which gives a guideline not only for planners, but for stakeholders, investors, municipalities and project-managers being involved in spatial planning too. For the current work some previous and similar guidebooks and strategies have been used. [11]

## 2 METHODOLOGY

### 2.1 Measurements

In the frame of a long-term human-bioclimate project initiated by the urban climate workgroup of the Department of Climatology and Landscape Ecology (University of Szeged), six local public areas with different surface morphology and function were investigated. The on-site data collection was carried out in 5 to 7 week long phases in the spring, summer and autumn of the project years 2011 and 2012.

During the environmental monitoring in local areas micro-meteorological parameters determining the thermal comfort (such as air temperature,  $T_a$ , relative humidity,  $RH$ , wind speed,  $v$ , and short- and long-wave radiation fluxes from the 3D environment) were measured on-site. Micro-meteorological data was registered by two mobile urban micrometeorological stations at a height of 1.1 m, as set by human-bioclimate guidelines. The stations were placed in different shading situations and on different land cover surfaces in local public areas in order to investigate the climatic effect of the urban vegetation and surface morphology. Based on on-site measured meteorological data, the mean radiation temperature,  $MRT$ , characterising the complex thermal effects of radiation conditions, and the physiologically equivalent temperature,  $PET$ , describing the thermal load on the human body were calculated.

Since data collection was carried out not at the same moment on different land covers (namely, we have only two mobile meteorological stations, however at least 4-5 different urban conditions) the simultaneous examination of the different land cover types was not possible. Therefore, the meteorological background parameters during the on-site measurements (such as air temperature, relative humidity, wind speed, and global radiation) were also used as obtained from the database of the meteorological station of the Hungarian Meteorological Service, Szeged. This meteorological station is located at a distance of about 6 km from the public spaces, in a typical suburb open grassy environment, without buildings and trees. During the data processing  $MRT$  and  $PET$  values in this latter case were also calculated from these background data.

### 2.2 Modelling

For modelling purposes the ENVI-met software was used. ENVI-met is a three-dimensional microscale climate model, which is capable of simulating the interactions of the physical environment and the microclimate with relatively high temporal (10 min) and spatial (0.5-10 m) resolution [12]. The simulation requires two groups of model input data. The 'Area input file' includes the morphological elements (buildings, plants, land covers etc.) and the 'Configuration file' contains the basic settings (such as the durations of the simulated time period and the time steps) as well as the necessary initial meteorological parameters related to the simulation.

### 2.3 The concept of the guide

After carrying out the described measurements and model simulations, the results are usually not appropriate for urban planners to understand and use in their planning routine. Typically, the results derived from the above described measurements and simulations are not easy to understand and use by practicing urban planners. Results of modelling might have complex messages, and it is also a long process to evaluate the findings. The results of simulations are often presented in a graphic display, but this can easily mislead to wrong or not precise conclusions. On the other hand, statistical evaluation that carries punctual data of several cases and measures, in order to prognosticate correctly the effects of a climate-adaptive intervention in urban environment, not only takes too long, but it is also a work which urban planners and landscape architects are usually not obliged to do. Therefore, what could help planners greatly in taking into consideration the effects of climate-adaptive tools, is to represent the different possible effects in a simple way. Thus, we have chosen to use the results of numerous measurements and modelling carried out during the last few years by the co-authors and sum up the mentioned results in a table. The table, which focuses mainly on summer outdoor thermal

comfort, must function as a part of a guide for designers in order to support and improve the effectiveness of climate-conscious urban planning. The guide should also be coherent with the Hungarian Building Code, and correspond to the requirements of typical municipality plans.

For giving a more detailed overview, the contents of the named tables are described in the following.

### 3 RESULTS

The mentioned tables sum up the changes occurring in the most important microclimatic characteristics due to the usage of some green-infrastructure elements. The investigated elements are the following: alleys, green spaces and paving materials. An alley is defined as a line of trees planted on one or both sides of the road between the pedestrian way and the carriageway, depending on the width of the street. Trees can be planted in different distances from each other. These features, of course, determine the amplitude of the microclimatic effects. Green space is an open space covered with dense vegetation (grass, shrubs, and trees) mainly meant for common use. Both tables summarise the most important characteristics of human thermal comfort. These are the following: air temperature ( $\Delta T_a$ ), mean radiant temperature ( $\Delta MRT^1$ ), wind velocity ( $\Delta v$ ) and human comfort ( $\Delta PET^2$  or  $\Delta PMV^3$ ). The first table (*Table 1.*) shows the minimising and maximising values of the possible changes occurring due to the usage of alleys, medium scale green spaces and different paving materials. Data on green spaces and paving materials are gained from on-site measurements, the effect of a simple alley is based on modelling results. The table helps designers to judge the possible “negative” and “positive” effects of the used green infrastructure element.

According to *Table 1.* the most effective way of minimising mean radiant temperature, and so improving thermal comfort, is the planting of an alley, as it can minimise the values of MRT by 34°C. On the other hand, the importance of using appropriate paving materials becomes also clear as medium dark stones increase air temperature by 3.7°C and mean radiant temperature by 24.6°C.

*Table 2.* describes even more simply the effects of some green infrastructure elements. This table is needed to give direct instructions: different urban environments might need changes in different ways, which can be solved with the usage of different elements of climate-adaptive planning. Facing the complex problematics of urban comfort one must take into consideration the possible changes affecting air temperature, surface temperatures and wind-environment at the same time. Bad thermal comfort needs complex answers using severe elements simultaneously. In order to get more detailed images of the planned site, microclimatological modelling might be still needed during the planning period with the parallel use of the guide, but it can greatly help designers to foresee the effects of their plans in terms of human thermal comfort.

Both tables show both “negative” and “positive” effects of green infrastructure elements. This does not mean that green infrastructure would have negative effects on long term in the classical meaning, but shows, that for achieving different aims one must use different tools. The negative values show the decrease, positive values show the increase in physical parameters. Thus, negative values, in most cases, represent a positive change from a thermal comfort point of view.

<sup>1</sup> MRT (Mean Radiant Temperature is the uniform temperature of an imaginary enclosure where the radiant heat fluxes equal to the actual, non-uniform environment [13]

<sup>2</sup> PET (Physiologically Equivalent Temperature) is a widely used human bioclimatology index. PET is defined as the air temperature at which, in a typical indoor setting, the heat budget of the body is

balanced with the same core and skin temperature as those under the prevailing complex outdoor conditions [14]

<sup>3</sup> PMV (Predicted Mean Vote) is a model taking into consideration heat balance equations developed by P.O. Fanger. The scale for outdoor environment is  $-4 < PMV < +4$

BENEFITS		mitigation of air temperature	mitigation of mean radiant temperature	change of wind speed	Human comfort
ELEMENT OF GREEN INFRASTRUCTURE		$\Delta T_a$ [°C]	$\Delta MRT$ [°C]	$\Delta v$ [m/s]	$\Delta PET$ [°C]
1	alley	min: -1 max: +0.1	min: -34 max: +2	min: 2-2,5 max: -0,25-1	min: -2,5 max: 0,5 [PMV]
2	green space	min: -1.8 max: 1.5	min: -32.6 max: 0.5	min: -9.2 max: 0.2	min: - 16.1 max: 3.1
3	covering / paving medium dark pave stone	min: -1.6 max: 3.7	min: -17.3 max: 24.6	min: -5.0 max: 1.7	min: -9.8 max: 13.5
	light-coloured gravel	min: -0.7 max: 3.2	min: -13.1 max: 19.5	min: -9.1 max: -0.7	min: -3.3 max: 14.6

Table 1: Minimum and maximum values of differences caused by the most important climate-adaptive tools.

BENEFITS		change of air temperature	change of mean radiant temperature	change of wind speed	Human comfort?
ELEMENT OF GREEN INFRASTRUCTURE		$\Delta T_a$ [°C]	$\Delta MRT$ [°C]	$\Delta v$ [m/s]	$\Delta PET$ [°C]
1	alley	-1	-34	-65% - +10%	-2.5 - +0.5 PMV
2	green space	-2.4	-36.3	-10.8	-16.1
3	covering / paving	+3.7	+31.3	-	+20.1
4	water surface	-0.006	No precise data available		
5	green façade	-0.3			
6	green roof	0			

Table 2: Characteristic values of changes in thermal environment occurred through the usage of different green infrastructure elements.

#### 4 DISCUSSION AND FURTHER PLANS

As introduced, this work is still an ongoing project and there are further plans to improve and extend the guide. The importance of involving urban planners in climate adaption is undeniable. The most important aim of the guide is to show the many possibilities, and both the responsibilities designers hold in creating a better urban environment.

For ensuring the coherence with the Hungarian planning system the guide must be cut down to different scales of urban planning, however the guide mainly concentrates on short-term and medium scale action plans. Moreover, during the further development of the guide, more elements of green infrastructure must be taken into consideration; the guide should give more precise data on different urban situations (e.g. orientation of roads, open spaces, etc.), and some more benefits too: such as energy use, storm water

runoff regulation, air quality and carbon sequestration.

There are also plans for testing the helpfulness and usefulness of the guide among practitioners, and enhance the quality and possibilities of usage based upon feedback.

## 5 REFERENCES

1. Bowler, D.,E., Buyung-Ali, L., Knight, T.M and Pullin A.S. (2010) Urban greening to cool towns and cities: A systematic review of the empirical evidence. *Landscape and Urban Planning* 97, 147–155.
2. Bruse M (2004) ENVI-met website. <http://www.envimet.com> [accessed January 2016]
3. CNT (Center for Neighborhood Technology) (2010) The Value of Green Infrastructure – A Guide to Recognizing Its Economic, Environmental and Social Benefits [http://www.cnt.org/sites/default/files/publications/CNT\\_Value-of-Green-Infrastructure.pdf](http://www.cnt.org/sites/default/files/publications/CNT_Value-of-Green-Infrastructure.pdf) (downloaded: 2016.01.20.)
4. D'Ippoliti, D., Michelozzi, P., Marino, C., de'Donato, F., Menne, B., Katsouyanni, K., Kirchmayer, U., Analitis, A., Medina-Ramón, M, Paldy, A., Atkinson, R., Kovats, S., Bisanti, L., Schneider, A., Lefranc, A., Iñiguez, C. and Perucci, C.A. (2010) The impact of heat waves on mortality in 9 European cities: results from the EuroHEAT project. *Environ Health* 9:37.
5. Égerházi, L.A., Kovács, A. and Unger, J. (2013) Application of microclimate modelling and onsite survey in planning practice related to an urban micro environment. *Advances in Meteorology*, Article ID: 251586.
6. Erell, E., Pearlmutter, D., Boneh, D. and Kutiel, P.B. (2011) Effect of high-albedo materials on pedestrian heat stress in urban street canyons. *Urban Climate* 10, 367-386.
7. Gál, T. and Unger, J. (2009) Detection of ventilation paths using high-resolution roughness parameter mapping in a large urban area. *Building and Environment* 44, 198–206.
8. Höppe P (1999) The physiological equivalent temperature – an universal index for the biometeorological assessment of the thermal environment. *Int J Biometeorol* 43:71-75
9. ISO 7726. Ergonomics of the thermal environment - Instrument for measuring physical quantities". Geneva, Switzerland: International Organization for Standardization. November 1998.
10. Kiss, M., Takács, Á., Pogácsás, R. and Gulyás, Á. (2015) The role of ecosystem services in climate and air quality in urban areas: Evaluating carbon sequestration and air pollution removal by street and park trees in Szeged (Hungary). *Moravian Geographical Reports* 23, 36-46.
11. Kántor, N., Égerházi, L. and Unger, J. (2012) Subjective estimations of thermal environment in recreational urban spaces - Part 1: investigations in Szeged, Hungary, *International Journal of Biometeorology* 56, 1075-1088.
12. Pongrácz, R., Bartholy, J., Bartha, B.E., Törék, O., Pieczka, I. and Torma, Cs. (2011) Projected changes of regional heat waves in Central/Eastern Europe using climate model simulations. 91st AMS Annual Meeting on „Communicating Weather and Climate”. <http://ams.confex.com/ams/91Annual/webprogram/Manuscript/Paper18581/PR-etal-161.pdf>, Seattle, WA. Paper 161, 7p.
13. Sun R and Chen L (2012) How can urban water bodies be designed for climate adaptation? *Landscape and Urban Planning* 105, 27– 33.
14. UN (United Nations, Department of Economic and Social Affairs, Population Division) (2014) *World Urbanization Prospects: The 2014 Revision, Highlights (ST/ESA/SER.A/352)*.





## Expanding Boundaries: Systems Thinking for the Built Environment

### COMPARISON OF DISTRICT HEATING SYSTEMS AND DISTRIBUTED GEOTHERMAL NETWORK FOR OPTIMAL EXERGETIC PERFORMANCE

P.M. Falk<sup>1\*</sup>, F. Meggers<sup>2</sup>, P. Stephan<sup>1</sup>, F. Dammel<sup>1</sup>

<sup>1</sup> Institute for Technical Thermodynamics, Technische Universität Darmstadt, Alarich-Weiss-Straße 10, 64287 Darmstadt, Germany

Darmstadt Graduate School of Excellence Energy Science and Engineering, Jovanka-Bontschits-Straße 2, 64287 Darmstadt, Germany

<sup>2</sup> School of Architecture and the Andlinger Center for Energy and the Environment, Princeton University, Princeton, NJ 08544 USA

\*Corresponding author; e-mail: falk@ttd.tu-darmstadt.de

#### Abstract

As part of the IEA ECB Annex 64, Low Exergy Communities, we investigate distributed heating and cooling systems using large campus infrastructures as baselines. The Princeton University system serves as a baseline with a 15MW combined heat and power facility that supplies heating in winter and cooling in summer. This paper assesses a low temperature hot water combined heat and power system and a geothermal system as two alternatives to the current system. The heating period of 2013/2014 is investigated. To assess the primary energy and exergy input required to meet the campus heating demand of 132.8 GWh, the existing system and a theoretical geothermal system are modelled using the MATLAB/Simulink based toolbox CARNOT. The combined heat and power system needs 338.1 GWh of exergy to meet the heat demand and to produce 63.1 GWh of electricity. The geothermal system only needs 219.6 GWh of exergy to meet the heating demand and to provide the same amount of electricity using the electricity grid. The energy efficiency of both investigated systems is equal, but one third of the geothermal system's energy input is renewable geothermal heat. Also, the exergy efficiency of the geothermal system is 30.7 %, whereas the combined heat and power system has an exergy efficiency of only 19.9 %.

#### Keywords:

Exergy analysis; geothermal borehole heat exchangers; combined heat and power; campus heating system; CARNOT; LowEx

### 1 INTRODUCTION AND BACKGROUND

The built environment uses one third of the world's end energy [1], of which more than fifty percent is used for room heating [2]. Room heating is a low exergy demand, but usually high exergy sources like fossil fuels are used to meet these heating demands. The International Energy Agency Annex 64 - LowEx Communities – Optimized Performance of Energy Supply Systems with Exergy Principles aims at providing the needed energy demand at the matching exergy level. The main focus of the Annex is the integration of low exergy thinking to facilitate the needed shift to renewable and greenhouse gas emission free energy systems in communities [3]. Tolga

Balta et al. [4], analyse a “low exergy heating system from the power plant through the heat pump to the building envelope”. They conclude that energy analysis alone is not sufficient to understand all factors of energy utilization processes. As another result, they identify the primary energy conversion as the largest exergy destruction of their system. Dalla Rosa et al. [5] present a low-temperature district heating concept. They show that a low-temperature operation has higher performance than a low-flow operation of a district heating system. Rosen et al. [6, 7] analyse combined heat and power (CHP) based district energy systems. The calculated energy and exergy efficiency is between 83 and

94% and 28 and 29%, respectively. Terés-Zubiaga et al. [8] analyse five different energy systems for a multifamily building in Spain. They identify combustion and resistance heating as biggest exergy losses. Lohani [9] analyses a condensing boiler and a ground and air source heat pump for a building for two different reference temperatures. Energy and exergy analyses show that the ground source heat pump with ambient reference temperature has the best performance. A good overview over the work on LowEx heating and cooling systems for buildings and communities can be found in Hepbasli [10]. The Princeton University is exploring a long-term plan for its campus heating system, which is currently a co-generation plant generating electricity and high-temperature steam. Alternatives include low temperature water distribution and switching to a geothermal heat pump. The historical data for campus energy demand and these future scenarios provide the context for this study.

## 2 METHODS

### 2.1 System Layout

The current Princeton University campus heating and cooling system has a central CHP plant which can be run using either natural gas or diesel fuel. The heating system is a steam system with temperatures and pressures up to 230°C and 14 bar. Two auxiliary boilers are available to meet the heating peak demand. The total heat demand during the heating period in 2013/2014 is  $E_{demand} = 132.8$  GWh and the electricity production of the CHP plant during that period is 63.1 GWh.

In this work, the heating systems are modelled as heating hot water systems with a supply temperature  $T_s$  of 50°C and a return temperature  $T_r$  of 35°C. The systems are simulated using measured demand data in 15 min time steps. Further, the campus is modelled as one single load with one supply and one return pipe with a length of 21 km each, a diameter of 0.82 m and a heat loss coefficient of 1.3 W/(m<sup>2</sup>K). For both systems, the energy needed to run the system pumps is neglected. The systems are modelled using the MATLAB/Simulink based toolbox CARNOT [11], which allows for a dynamic simulation of the heating period. Different couples of supply and return temperatures are developed for the simulation to explore effects on system operating conditions.

#### 2.1.1 CHP System

The low temperature heating hot water CHP system is modelled as a central CHP plant with 15 MW electric and 21 MW thermal output, (fig. 1). The electric and thermal efficiency of the CHP plant is set constant to 25.6% and 36.9%. An auxiliary boiler with an efficiency of 78% is implemented to meet the heating peak demand. A thermal energy storage in the form of a hot water

storage with a volume of 85 m<sup>3</sup> is used to prolong the running time of the CHP plant.

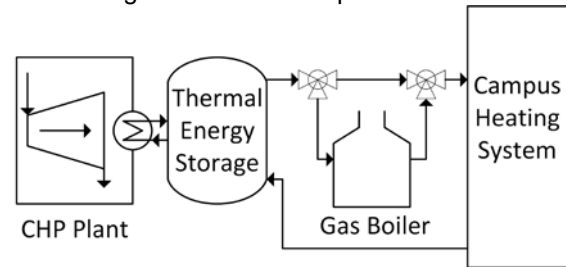

Fig. 1: CHP System.

#### 2.2.2 Geothermal System

As a second alternative to the current system, a geothermal heat pump system is analysed, (fig. 2). It consists of a borehole field with vertical ground-source heat exchangers modelled as double-U-pipe heat exchangers with a depth of 96 m. To limit computing time, the borehole field and heat pump are modelled as a small system with a thermal power output of 121 kW. The nominal coefficient of performance (COP) of the heat pump is 3.6. In order to meet the demand of the campus heating system, the input and output energy and mass flows are scaled up in front of the thermal energy storage. The storage is used to even out demand peaks and is modelled as a hot water storage with a volume of 200 m<sup>3</sup>.

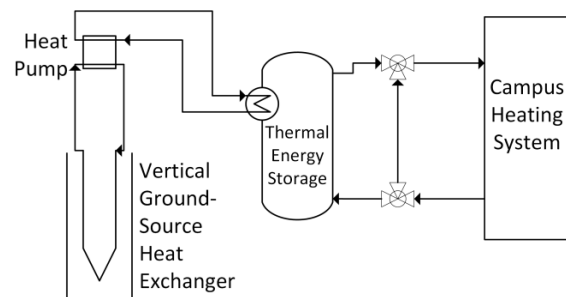

Fig. 2: Geothermal System with Heat Pump.

### 2.2 System Boundary and Reference State

The current outside air is chosen as reference environment according to the IEA Annex 49 guidebook [12]. In this paper the outside air temperature for the heating period 2013/2014 in Princeton, USA, is taken as reference temperature.

The system boundary is chosen according to the storability criterion developed by Jentsch [13]. The storability criterion demands that all energy forms are traced back to a storable form. The energy inputs crossing the system boundary are the gas needed for the CHP plant, the primary energy needed to run the heat pump and the geothermal energy. The energy needed to run the system pumps is not included in the analysis at this stage.



### 2.3 Exergy Definition

*Exergy of natural gas:* The exergy of natural gas  $L_{ex,NG}$  is defined as [14]:

$$L_{ex,NG} = \beta_{NG,LHV} LHV, \quad (1)$$

where  $\beta_{NG,LHV}$  is the quality factor for natural gas (NG) and  $LHV$  is the lower heating value for natural gas. In this work,  $\beta_{NG,LHV} \approx 1.04$  is used [15].

*Exergy of geothermal heat:* The exergy equation for heat is used to calculate the exergy content of the heat input at the borehole:

$$-P_{ex} = \dot{Q}(1 - T_0/T_\infty), \quad (2)$$

where  $P_{ex}$  is the exergy flow,  $\dot{Q}$  is the heat flow from the geothermal heat source,  $T_0$  is the reference temperature and  $T_\infty$  is the undisturbed ground temperature in half of the depth of the borehole.

*Exergy demand of the campus:* The exergy demand of the campus is calculated using the exergy equation for heat:

$$-P_{ex} = \dot{Q}_C(1 - T_0/T_B), \quad (3)$$

where  $P_{ex}$  is the exergy flow,  $\dot{Q}_C$  is the campus heat demand,  $T_0$  is the reference temperature and  $T_B$  is the desired temperature inside the campus buildings, which is set to 21 °C.

*Exergy of electricity:* For electricity, its energy and exergy content is equal. Because of the storability criterion, electricity is traced back to the primary exergy input and the transformation losses are taken into account. Because the exergy and energy efficiency for various types of power plants is similar [16], the following equation is used to calculate the energy efficiency  $\eta_{el}$  and exergy efficiency  $\psi_{el}$  for electricity:

$$\eta_{el} = \frac{\sum_i \sigma_i \eta_i}{\sum_i \sigma_i} = \psi_{el} = \frac{\sum_i \sigma_i \psi_i}{\sum_i \sigma_i}, \quad (4)$$

where  $\sigma_i$  are the percentages of the different kinds of electricity sources on the total electricity supply mix of the USA of the year 2014 [17].  $\eta_i$  and  $\psi_i$  are the energy and exergy efficiency of the different kinds of electricity sources. In table 1, the values for  $\sigma_i$ ,  $\eta_i$  and  $\psi_i$  are given.

It is assumed that natural gas and oil have the same transformation efficiency and that renewable energies have an efficiency of 100%. Other energy sources than the ones shown in table 1 are neglected. With table 1 and equation 4  $\eta_{el}$  and  $\psi_{el}$  can be calculated to  $\eta_{el}$  and  $\psi_{el} = 0.48$ .

	Renewable	Oil	Coal	Nuclear	Gas
$\sigma_i$	13 %	1 %	39 %	19 %	27 %
$\eta_i / \psi_i$	100 %	52.6 %	36 % [16]	30 % [16]	52.6 % [18]

Table 1: Share on the electricity generation and efficiency values of different energy sources.

### 2.4 Characteristic Numbers

The overall system energy efficiency  $\eta_{system}$  is defined as:

$$\eta_{system} = \frac{E_{demand} + E_{el}}{E_{fossil} + E_{geothermal}}, \quad (5)$$

where  $E_{fossil}$  is the fossil energy input into either the CHP and boiler or the heat pump,  $E_{el}$  is the electricity produced by the CHP plant and  $E_{geothermal}$  is the energy extracted from the boreholes. It is dependent on the system layout if  $E_{geothermal}$  is applicable. The CHP system produces heat and electricity, whereas the geothermal system only produces heat. A comparison of the two systems is difficult since the output is not equal for both systems. This is due to the fact that the geothermal system cannot produce electricity and would therefore only have the produced heat in the numerator of equation 5. The following measure is taken to make the numerator of equation 5 equal for both systems.

The amount of electricity which the CHP plant produces is also used for the efficiency calculation of the geothermal system, so that the numerator is equal. Since the geothermal system cannot produce electricity it is assumed that the geothermal system pulls the amount of electricity which the CHP plant produces from the electricity grid. This electricity is named as compensated grid electricity. The compensated grid electricity is taken from the electricity grid and must therefore be traced back to the primary energy conversion using equation 4.

The overall system exergy efficiency  $\psi_{system}$  is defined as:

$$\psi_{system} = \frac{EX_{demand} + EX_{el}}{EX_{fossil} + EX_{geothermal}}, \quad (6)$$

where  $EX_{fossil}$  is the fossil exergy input into either the CHP or the heat pump system,  $EX_{el}$  is the electricity produced by the CHP plant and  $EX_{geothermal}$  is the exergy extracted from the boreholes. It is dependent on the system layout if  $EX_{geothermal}$  is applicable. Again, as for equation 5, a compensated grid electricity for the geothermal system is calculated using equation 4.

## 3 RESULTS

In the energy and exergy efficiency comparison, the CHP and the geothermal system have a similar energy efficiency, but the geothermal system has a higher exergy efficiency (fig. 3).

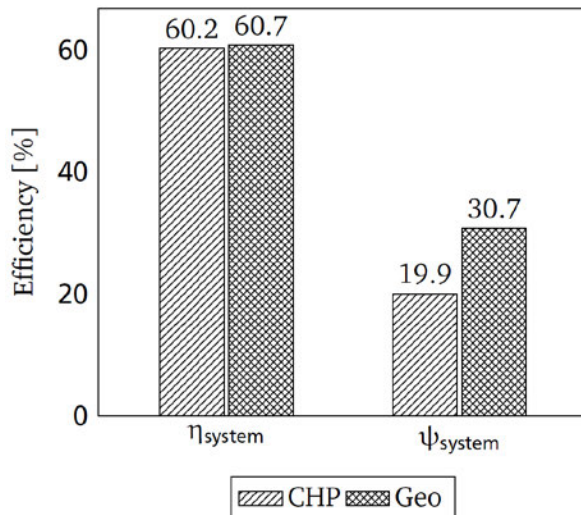

Fig. 3: Energy and Exergy efficiency of the two systems.

Although the CHP and the geothermal system have almost the same energy input into the system of 325.1 GWh and 322.4 GWh respectively, the geothermal system has one third of its energy input from geothermal heat, which is renewable, whereas the CHP system has only fossil fuel input (fig. 4).

Since geothermal heat is a low exergy heat source, the exergy input into the geothermal system at 218.7 GWh is lower than its energy input. The grey bar “Comp. Electricity” (fig. 4) is the compensated grid electricity introduced in section 5 in order to make a comparison of the two investigated systems possible, calculated with equation 4. The exergy input into the CHP system is 338.1 GWh.

The influence of different supply and return temperatures is investigated (fig 5). The couples of supply and return temperatures were determined to be 50/35 °C, 60/45 °C, 70/50 °C and 90/70 °C. The pipe losses increase with increasing system temperatures (fig 5). The electricity production of the CHP plant decreases slightly with increasing system temperatures because of the control strategy of the thermal energy storage. The energy input into the CHP system does not increase as much as the pipe losses with increasing temperature. Since the CHP plant produces less electricity due to the chosen storage control strategy, it also produces less heat. In order to cover the heat demand, the auxiliary boiler produces more heat.

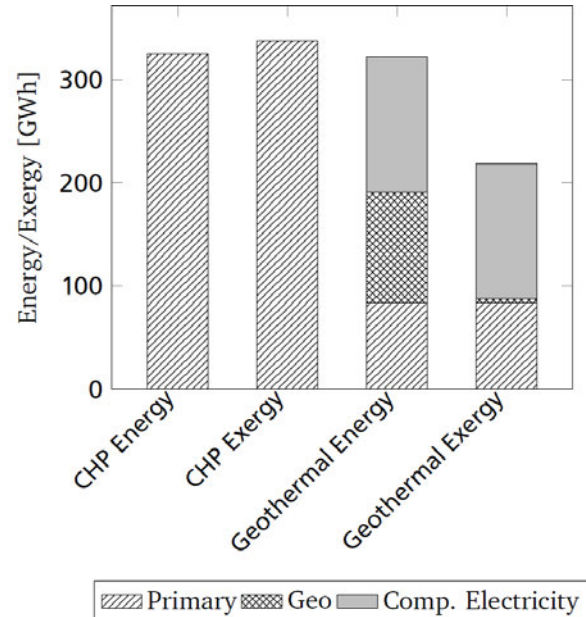

Fig. 4: Energy and Exergy Input of the two Systems.

The auxiliary boiler has a higher energy efficiency than the CHP plant. This leads to a smaller increase of energy input with increasing temperatures compared to the increase of pipe losses. The energy input into the heat pump increases more than the pipe losses, because the heat pump's COP decreases from 3.6 at 50 °C to 2.9 at 60 °C when the heat pump has to cover a higher temperature spread. The total energy input into the geothermal system also increases. The compensated grid electricity of the geothermal system is not included in the total energy input (fig. 5).

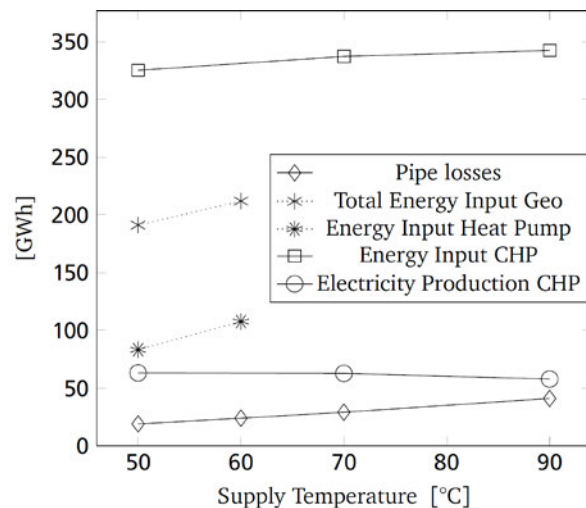

Fig. 5: Influence of Supply Temperature.

## 4 DISCUSSION

Since the CHP and the geothermal systems have different energy products as an outcome, a compensated grid electricity of the geothermal system is calculated to make the two systems comparable. The results show better performance for the geothermal system, but the energy needed to run the system pumps is not taken into account. The pump energy needed to run the geothermal system is higher than for the CHP system because more fluid circuits have to be implemented. First estimations put the pump power to run the pumps of the CHP system to around 20.0 GWh and to run the pumps of the geothermal system to around 45.0 GWh. For both systems simplifying assumptions have been made for the simulation. The main assumptions are that the CHP plant has a constant efficiency and that one simulated heat pump and borehole system can be up scaled linearly. In reality, a large array of heat pumps and boreholes would be needed to cover such a high demand, which would provide additional opportunities for optimization. The results are strongly dependent on the chosen electrical efficiency of the CHP plant and the COP of the heat pump. By operating a large set of boreholes extraction temperatures can be optimized to increase the overall COP, while the pumping costs would be more distributed. Even though the geothermal system needs a slightly higher amount of energy to produce the same output, when the pump energy demand estimation is taken into account, roughly one third of its input is geothermal heat which is a renewable, low exergy heat source, making it a better choice from a sustainable and exergy point of view. Changing the supply and return temperatures affects not only the energy balance, but a reduction of supply temperatures would presumably also require additional measures on the buildings itself regarding heat transfer stations and radiators.

## 5 CONCLUSION

Two alternatives to the Princeton University campus heating system are modelled to provide the needed heat. A low temperature heating hot water CHP system consisting of a CHP plant and an auxiliary boiler is compared to a geothermal system consisting of a borehole field and a heat pump. The results show that the geothermal system has a higher share of renewable energy and has better exergetic performance for the input parameters, and energy conditioned determined from historical operation. This is in part due to one third of its energy input being renewable energy and its exergy efficiency is 30.7%, whereas the CHP system has an exergy efficiency of only 19.9%. A compensated grid electricity use for the geothermal system is calculated to make the geothermal system comparable to the CHP that produces electricity and the energy

efficiency for both systems is around 60%. These results provide valuable input into the planning process of the future Princeton campus system considering the effect of exergy that is often overlooked. The variation of the supply and return temperatures shows that the total energy input into both systems decreases with decreasing system temperatures, because of decreasing pipe losses. Heat pumps benefit even more from decreasing system temperatures, because the temperature spread that they have to overcome to provide heat at the desired temperature decreases, which leads to a higher COP. Overall, the geothermal system seems to have a superior performance, but the results are strongly dependent on the CHP plant efficiency and the heat pump COP. Both values should be increased. In general it is demonstrated that exergy analysis helps finding the more suitable of the two investigated heat supply alternatives. In further studies the energy needed to run the system pumps should be included in the analysis. To which degree a reduction of supply and return temperatures is realizable for the Princeton University campus heating system has to be determined in further studies.

## 6 ACKNOWLEDGMENTS

The work is conducted in the framework of the International Energy Agency Annex 64: LowEx Communities - Optimized Performance of Community Energy Supply Systems with Exergy Principles and is financially supported by the DFG in the framework of the Excellence Initiative, Darmstadt Graduate School of Excellence Energy Science and Engineering (GSC 1070). CARNOT was developed by the Solar-Institut Jülich, Germany, and is available there at no charge. The demand data of the Princeton University campus heating system was kindly provided by Princeton University, USA.

## 7 REFERENCES

1. IEA, Energy Efficiency, URL <https://www.iea.org/aboutus/faqs/energyefficiency/>
2. IEA, Worldwide Trends in Energy Use and Efficiency, 2008. URL [https://www.iea.org/publications/freepublications/publication/Indicators\\_2008.pdf](https://www.iea.org/publications/freepublications/publication/Indicators_2008.pdf)
3. IEA EBC Annex 64, LowEx Communities - Optimised Performance of Energy Supply Systems with Exergy Principles. URL <http://www.annex64.org/>
4. M. Tolga Balta, Y. Kalinci, A. Hepbasli, Evaluating a low exergy heating system from the power plant through the heat pump to the building envelope, Energy and Buildings 40 (10) (2008) 1799-1804. doi: 10.1016/j.enbuild.2008.03.008.

5. A. Dalla Rosa, J. E. Christensen, Low-energy district heating in energy efficient building areas, *Energy* 36 (12) (2011) 6890-6899. doi:10.1016/j.energy.2011.10.001.
6. M. A. Rosen, M. N. Le, I. Dincer, Efficiency analysis of a cogeneration and district energy system, *Applied Thermal Engineering* 25 (1) (2005) 147-159. doi:10.1016/j.applthermaleng.2004.05.008.
7. M. A. Rosen, M. N. Le, I. Dincer, Exergetic analysis of cogeneration-based district energy systems, *Proceedings of the Institution of Mechanical Engineers, Part A: Journal of Power and Energy* 218 (6) (2004) 369-375. doi:10.1243/0957650041761892.
8. J. Terés-Zubiaga, S. Jansen, P. Luscuere, J. Sala, Dynamic exergy analysis of energy systems for a social dwelling and exergy based system improvement, *Energy and Buildings* 64 (2013) 359-371. doi:10.1016/j.enbuild.2013.05.034.
9. S. Lohani, Energy and exergy analysis of fossil plant and heat pump building heating system at two different dead-state temperatures, *Energy* 35 (8) (2010) 3323-3331. doi:10.1016/j.enenergy.2010.04.018.
10. A. Hepbasli, Low exergy (LowEx) heating and cooling systems for sustainable buildings and societies, *Renewable and Sustainable Energy Reviews* 16 (1) (2012) 73-104. doi:10.1016/j.rser.2011.07.138.
11. Solar Institut Jülich Germany, CARNOT 5.3: Matlab simulink toolbox extension (1999).
12. H. Torío, D. Schmidt, Detailed Exergy Assessment Guidebook for the Built Environment: ECBCS Annex 49 - Low Exergy Systems for High- Performance Buildings and Communities, Fraunhofer Verlag, Stuttgart, 2011. URL [http://www.annex49.info/download/Annex49\\_guid ebook.pdf](http://www.annex49.info/download/Annex49_guid ebook.pdf)
13. A. Jentsch, A novel exergy-based concept of thermodynamic quality and its application to energy system evaluation and process analysis, 2010. URL <http://opus.kobv.de/tuberlin/volltexte/2010/2576/>
14. A. Hepbasli, A study on estimating the energetic and exergetic prices of various residential energy sources, *Energy and Buildings* 40 (3) (2008) 308-315. doi:10.1016/j.enbuild.2007.01.023.
15. S. Bargel, Entwicklung eines exergie-basierten Analysemodells zum umfassenden Technologievergleich von Wärmeversorgungssystemen unter Berücksichtigung des Einflusses einer veränderlichen Außentemperatur, Ph.D. thesis, Ruhr Universität Bochum, Germany. URL <http://www-brs.ub.ruhr-uni-bochum.de/netahtml/HS/Diss/BargelStefan/diss.pdf>
16. M. A. Rosen, Energy- and exergy-based comparison of coal-fired and nuclear steam power plants, *Exergy, An International Journal* 1 (3) (2001) 180-192. doi:10.1016/S1164-0235(01)00024-3.
17. U.S. Energy Information Administration, U.S. electricity generation by energy source 2014 (2015). URL <https://www.eia.gov/tools/faqs/faq.cfm?id=427&t=3>
18. G. P. Hammond, Ondo Akwe, Serge S., Thermodynamic and related analysis of natural gas combined cycle power plants with and without carbon sequestration, *International Journal of Energy Research* 31 (12) (2007) 1180-1201. doi:10.1002/er.1328.



## Expanding Boundaries: Systems Thinking for the Built Environment

### CAMPUS AS A LAB: BUILDING- AND SYSTEM-LEVEL AIR MOVEMENT INVESTIGATION

E. Teitelbaum<sup>1\*</sup>, S. Urano<sup>2</sup>, L. Conlan<sup>1</sup>, A. Percival<sup>2</sup>, J. Hinson<sup>3</sup>, F. Meggers<sup>2,4</sup>

<sup>1</sup>Civil and Environmental Engineering, Princeton University, USA

<sup>2</sup>School of Architecture, Princeton University, USA

<sup>3</sup>Princeton High School, USA

<sup>4</sup>Andlinger Center for Energy and the Environment, Princeton University, USA

\*Corresponding author; e-mail: eteitelb@princeton.edu

#### Abstract

The successful realization of an architectural narrative through engineering is intimately entangled with stochastic events of which advanced models, such as CFD or energy modelling, do not navigate. Through a series of investigations within air spaces around campus buildings at large, i.e. atrium, and small, i.e. double skin facades, scales, this study demonstrates the actual movement of air within these spaces and seeks to compare them with the design narrative and any calculations put forward by engineers prior to construction. Additionally, we propose new, informative methods of visualization for our results, modifying standard arrow conventions to provide more information about the probability of observed performance modes. While such an in-depth computational analysis is only possible with real data available after building completion, we claim that the methods developed in this approach and the associated results may still inform the planning process when sizing equipment and engineering control logic.

#### Keywords:

Double skin façade; Sensors; Arduino; Air movement; Convection

## 1 INTRODUCTION

Buildings are often designed to take advantage of natural air movements. This is commonly seen in buildings with large atria and with narrow cross section where thermal free convection and wind-driven cross ventilation are used as strategies to increase comfort without any energy demand. Unfortunately, the design process makes gross assumptions about the reliability of these natural flows, and the implementation often performs in ways not addressed in the design process, and not measured after completion. Natural ventilation is designed using prevailing winds and average wind speeds. But prevailing wind is exactly that: prevailing, not constant. Speeds and direction are highly volatile, and significant periods of time in any location will have non-ideal wind speeds and directions, rendering achieving reliable natural ventilation difficult.

Another aspect that airflow design relies on is free convection, where the height of atria is used to move hot air upward or cool air downward. Unfortunately, the interaction of heat flux and air movement is difficult to predict.

In most cases, airflow inside the building volume is represented by architects as arrows that are essentially estimations based on first principles or heuristics. In the best case, some analysis or simulation has been carried out, but in general they are not representative of the highly dynamic conditions at the interface of air flows inside and outside the building. A post occupancy analysis of airflow in building spaces, which have been designed based on predictions of complex natural ventilation and/or convection, will provide valuable insight into the reality of air movement in buildings and facilitate maximizing performance.

In general, if a natural ventilation system fails to meet comfort criteria, this is easily compensated

by air conditioning systems (often oversized with large factors of safety). The windows are closed and the system compensates. But in order to reach higher performance levels some buildings strive for completely natural ventilation operation. The Federal Building in San Francisco was built with a design criteria of complete natural ventilation. Unfortunately, in a survey by the US General Administration showed that although the Federal Building had 10% lower operational costs, the occupant satisfaction rate was only 13%, with the next lowest building being 26% [1], showing that the natural ventilation systems was causing significant comfort problems as well as acoustic and lighting problems. Another example is the Sandra Day O'Connor Courthouse in Phoenix, Arizona. A very novel evaporative cooling mist system for the atrium was developed by Arup and analysed by Raman [2], using an extensive CFD modelling process before being installed by ARUP. Yet despite the development of an independent CFD model for the system, predicting the evaporation and free convection was very difficult.

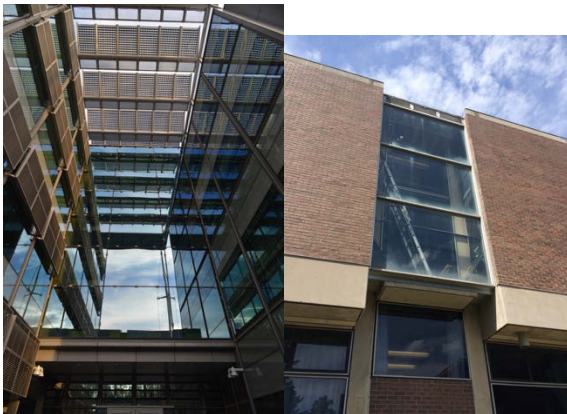

*Fig. 1: (a - left) Frick chemistry atrium; (b-right) Double skin façade with a ladder placed inside.*

At Princeton we have many buildings that have interesting and complex spaces that were designed with a specific preconception of the airflow in the space. One of the oldest is the lofted studio space of the School of Architecture which was retrofitted with a double skin façade 15 years after the building's opening to address comfort thermal issues (Fig 1b). The new Frick Chemistry Laboratory building (Fig. 1a) has a large atrium designed by Hopkins architects and Arup engineers, which is supplied by outside air that is efficiently first brought in through the adjacent offices. The building also includes radiant heating near the entrances, the operation of which is dependent on the airflows.

The buildings can be analysed using a novel setup leveraging wireless Wi-Fi-enabled networked microcontrollers called Particle Cores. Particle Cores collect data from sensors, such as temperature, humidity, differential pressure, infrared temperature, etc. and publish the values

to the Particle Cloud, a privately hosted platform accessible from anyone connected to the internet. Sensor values can be collected by polling the cloud and stored in a database or similar format. They can be battery powered, hung throughout the space, and have temperature and humidity sensors attached to them to track conditions relayed back to our own servers, making an ideally flexible and highly distributed platform to measure the resulting conditions in these airspaces and reconsider the predictions made in their design.

## 2 METHODS

The study is broken into two primary components, building-level investigations of the atrium space in Frick Chemistry building, and systems-level investigations of the double skin façade (DSF) in the school of architecture. The breakdown reflects the scale of each problem, and while a double skin façade will have impacts on the entire building's energy consumption, we are only concerned with heat transfer within the space. The entire study contains multiple datasets in other buildings around campus for comparisons of similar features in different settings.

### 2.1 Building-level Atrium study

As mentioned in section 1, the atrium in Frick was the first large atrium space studied as part of the Campus as a Lab investigation. The atrium, approximately 90 m by 10 m by 20 m high, represents a considerable volume of air. The energy-conscious narrative of the building design dictates that for summer operation, air is conventionally cooled upon entering the building on east side, where the majority of the offices are located. Air warms up while moved through the office space, and is directed towards the atrium. Fume hoods and a laboratory air handler unit on the western side of the building circulate the warmed air through the lab space, and out of the building. This allows the atrium to be ventilated as an interstitial space with minimal fan power. But this results in dependency on complex free convection flows.

Engineers ran CFD simulations to predict airflow before the building was constructed. To compare these models with actual data, we placed sensors on floors 1, 2, and 3, at 3 locations (north, central, and south), for the east, west, and central portions of the building. Altogether, 27 sensor locations were used, not including a seldom-pollled sensor that remained on the ground floor. This sensor was subject to disturbances by occupants and the lower level café. Air temperature and humidity sensors (DHT22) were attached to handrails as shown in fig. 2.

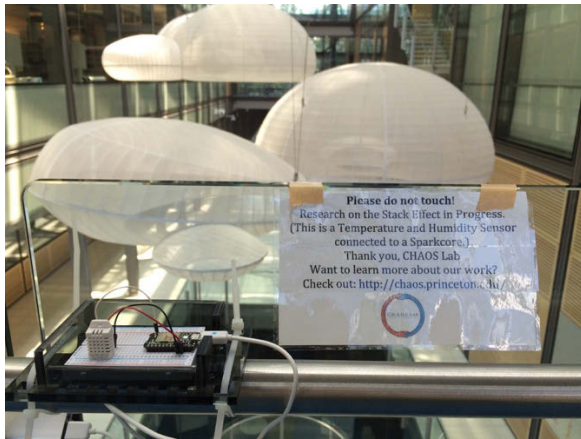

Fig. 2: Air temperature and humidity sensor connected to a Particle Core placed in Frick.

## 2.2 Systems-level DSF study

The Double Skin Facade in the Princeton University School of Architecture is a particularly interesting space as it is a retrofit to improve energy performance and thermal comfort levels in the building. The large windows were initially designed with large curtains, however the large windows are between 1/3 and 1/2 of the overall wall surface area. During the energy crisis in the 1970s and into the 1980s, a new energy retrofit company cofounded by Harrison Fraker was called upon to design and install moveable skylights and the operable DSF to improve energy performance. The skylights were phased out in subsequent retrofits, but the DSF, while inoperable in most areas, is still in place today.

According to discussions with the designers, some heuristic techniques were employed with 1970s technology to determine the contribution of the DSF retrofit to the energy consumption of the building. The guiding prediction was for winter operation the closed cavity would provide additional insulation, and in summer the vents in the cavity would open and free convection would circulate air through the space to keep it cool. No record exists today of these performance predictions.

To track the air motion, and evaluate the ability of the space to be ventilated by complex free convection in summer, sensors were semi-permanently installed to glass surfaces inside the double skin façade and hard-wired to facilitate data collection. Air temperature and humidity sensors (DHT22) were installed at 19.5", 77.5", 116", and 191". Air temperature and humidity inside the building were also monitored at the bottom of the system. Surface temperature sensors (Omega ON-409-PP) were installed inside the DSF on the exterior glass, interior glass, and inside the building on the glass at the same height as the two surface temperature sensors to model heat transfer through the space. Additionally, the space was outfitted with a differential pressure sensor (Sensirion SDP610-125PA) at the top of the cavity to track

the pressure generated in the cavity. The differential pressure sensor had a range of +/- 125 Pa. A +/- 25 Pa sensor would have sufficed.

A Python script was written to log data for days, at 90 second intervals. Intermittency of the Wi-Fi connection proved fatal to the script frequently, however over the course of several months, a large amount of data was taken.

In addition to sensors that were installed by the authors, Weather Underground information was polled from a nearby weather station. Data used included ambient temperature, humidity, solar radiation, wind velocity, and wind direction. These variables were monitored to provide an understanding for the observations inside the cavity.

Smoke tube imaging techniques were also employed to track air motion for creating diagrams.

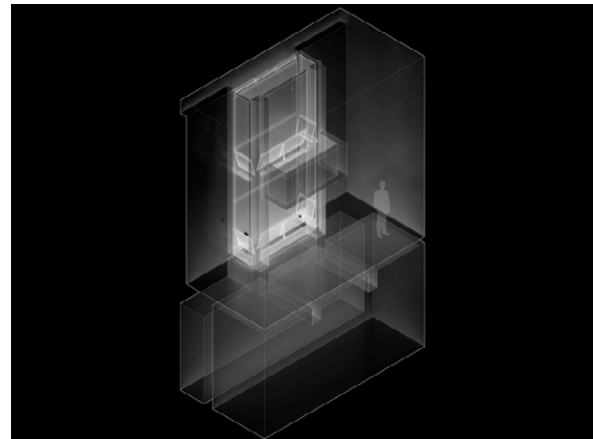

Fig 3: Rendering of the DSF

The results were interpreted to create a realistic figure showing temperature profiles, actual airflow patterns dictated by actual weather patterns.

## 3 RESULTS

### 3.1 Building-level Atrium study

Original drawing sets and documentation from the design of the building helped to characterize design intent. From some research into the building design stage, CFD simulations were uncovered which document the anticipated operation of the atrium. These images are shown in Fig. 4.

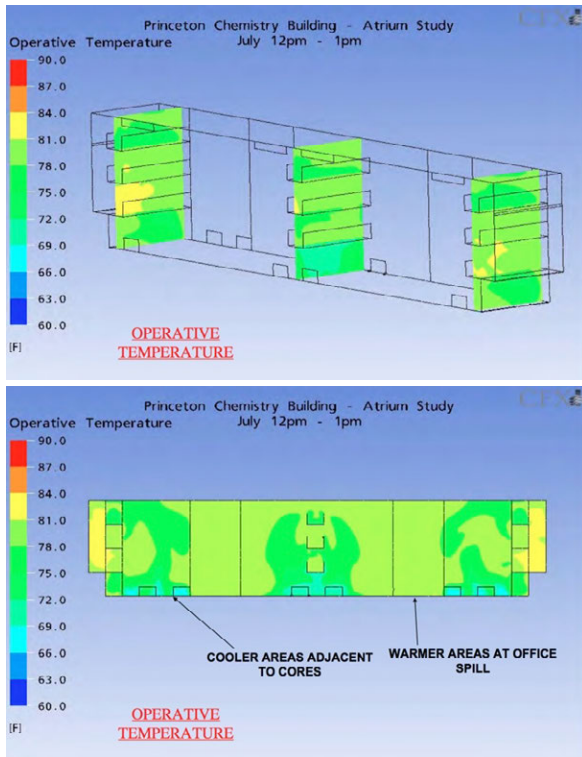

Fig. 4: Transverse and longitudinal cross-sections of temperature profiles from CFD simulations.

It is clear that engineers anticipate the warmest regions being at the north and south ends of the building, with the coolest regions in the centre of the building, with the warm regions being near the “office spill”, i.e. air exiting the offices.

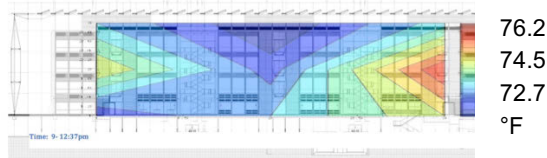

Fig. 5: Measured temperature in Frick Atrium.

Compared to our own measurements shown in Fig. 5, we are in agreement that between 12:00 and 13:00 in July, the warmest regions are at the north and south ends of the building. This image is comprised of averages over a 1 hour period of 10-15 measurements, depending on sensor connectivity. Due to resolution of the sensor mesh, we cannot rule out the existence of the northern and southern cool regions, however our readings confirm cool temperature in the middle of the building. Additionally, fig. 5 shows a decrease of temperature as one goes up in the building. This is a counterintuitive result that is not indicative of buoyancy driven free convection, and could be investigated with a finer resolution sensor mesh. It could be due to the speed of the air intakes that supply the laboratory space near the top of the atrium. This gives an indication that the assumed buoyant airflow and cold-on-bottom

hot-on-top may not be as prevalent in the space as considered in the design phase. This is by no means an indication that the space has failed as the space has enough conditioning capacity to meet the demand, but it does demonstrate the challenge in predicting realistic airflow scenarios.

Sensor reliability issues in the large atrium were immediately obvious when taking measurements of air temperatures in this space. Intermittent temperature readings made obtaining a time-series dataset difficult, while this was an original research goal. Future studies may want to consider using a more robust sensing protocol.

### 3.2 Systems-level DSF Study

The DSF study was to some extent simpler to implement than the atrium study due to the smaller size of the feature. Fig. 6 shows non-uniformity of the daily temperature profiles as height increases. All plots in fig. 6 show data from the spring for the temperature at different heights throughout the day inside the DSF.

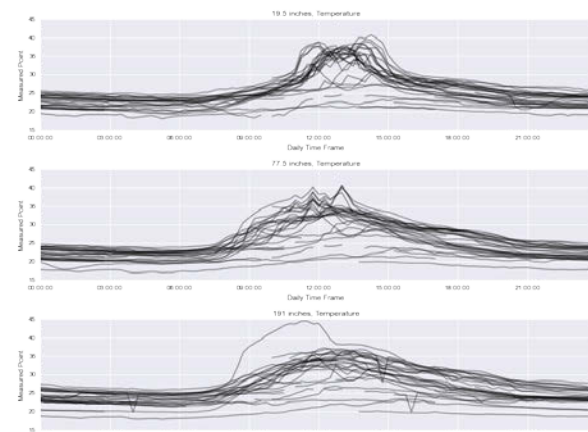

Fig. 6: Spring-time daily temperature profiles inside the DSF at 19.5”, 77.5”, and 191”.

The nonuniformity of the temperature profiles is particularly interesting because it demonstrates the complexity of the feature that cannot be predicted with heuristic design approximations. Fluctuations due to cloud cover, tree shadows, etc. seem to be “smoothed” out as height increases. In other words, the lowest temperature sensor in the DSF was subject to faster fluctuations, whereas the higher temperature sensors generated smoother daily contours.

Conceptually, these leads should be indicative of a buoyancy-driven temperature gradient. More specifically, as air heats up it will rise and exit the space. However, eventually the capacity of the air escape mechanism seems to be exceeded during the warmest parts of the day, and this DSF air turnover rate is no longer able to maintain a smooth profile throughout the space, resulting in even the lower sections heating up.





*Fig. 7: (a – top) Daily temperature profiles and averages (opaque lines) for spring-time operation of the DSF at varying heights; (b – middle) Time derivative of temperature change throughout the day at each height; (c – bottom) wind and differential pressure averages for the DSF.*

Fig. 7a, shows averages as heavier lines, and the lighter lines are actual daily trends. Again, one sees the buildup of temperature throughout the cavity during the day. Initially, the top is the warmest, until the warm air rises and is unable to escape at sufficient velocities.

The time-series derivative reflects this concept as well, shown in Fig. 7b. Initially, the top heats at the same rate as the middle two regions, until the top stabilizes. Eventually, there is a quick spike in

the bottom temperature, however this is relatively short-lived. Since the integral of the derivatives must be zero, Fig. 7b implies that the quick increase in temperature at the lowest region is met with a quick decrease in temperature beginning at approximately 13:00.

This conceptual understanding of the space that is provided from high time-resolution of the measurements shows that the cavity's air throughput is significantly undersized. Larger

vents would allow for faster turnover, and perhaps the sharp temperature increase would not be observed.

Further complexities within the DSF are introduced in Fig. 7c. Again, the opaque lines represent the daily (summer) averages, and the transparent lines represent individual days. Overall, there is a relatively constant pressure difference between the cavity and the exterior. Pressure buildup is mitigated to some extent through the vents. However, short fluctuations in wind speed generate large changes, up to 100%, the equilibrium differential pressure. This is significantly larger than the buoyancy driven flow, and difficult to plan for or control.

Fig. 7c also implies correlation between wind velocity and differential pressure, as the increase in prevailing wind during the day on average tends to be accompanied by an increase in differential pressure. This correlation may not imply causation, as this may also coincide with the building's air handling unit starting up for the day. A separate investigation will need to look at values when it is known the air handler unit is off.

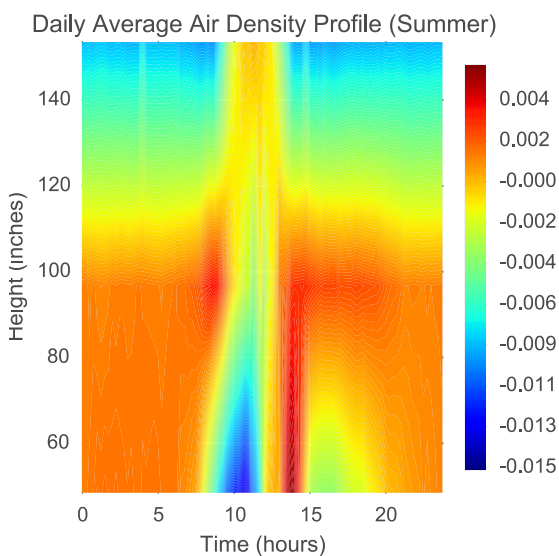

Fig. 8: Daily average air density differences between sensors.

Calculations of air density differences between the temperature sensors to inform Raleigh number calculations to observe the onset of free convection revealed an environment that does not have a characteristic free convection cavity. Instead, a stable conductive space is observed.

Fig. 8 shows air density differences in  $\text{kg m}^{-3}$ , calculated from the temperature differential between sensor locations. Orange (bottom) through blue (top) represents a density difference that favours natural convection, whereas a blue value at the bottom of the cavity shows air temperatures that will not create a draft in the cavity. By comparing this map to the temperature profile at a given height based on the time on the

abscissa, one can see the temperature profile that corresponds to a particular density profile. It appears that despite warm temperatures in the bottom of the cavity after 12:00 from direct sunlight, overall there are frequent changes in the modality of the feature, switching between freely convecting and stagnant.



Fig. 9: Smoke tube test of the DSF.

For visualization purposes, smoke tube tests were performed to see how air moved around the cavity inside the building. This showed the draw of fresh air up into the cavity, and informed imaging of the actual air movement around the space.

#### 4 DISCUSSION AND CONCLUSION

This study was particularly helpful in highlighting failures of a strictly narrative-based approach to design. For instance, when planning a DSF, the guiding principles of hot air rising and performing basic calculations to predict the vents required to maximize air throughput does not sufficiently describe this complex phenomenon.

The results presented in this paper are not meant to strictly inform design, either. It is recognized that complex spaces have a large number of variables that influence air motion, variables that are not isolated in the datasets presented here. Instead, stochastic performance is represented as simply stochastic. The novel part of this examination is that through the proliferation of cheap sensors, complex spaces and buildings of the future may benefit from controls algorithms that are fed high resolution data which is used to open vents, change fan speeds, etc. The possibilities are numerous.

Perhaps the biggest success of this study was using real data to inform imaging. A drawback with standard architectural representations is the lack of precision with arrows and conceptual illustration that oversimplify complex phenomena like airflow. Arrows directing airflow have become ubiquitous, however the exact interpretation is infrequently specified. Fig. 10 shows a figure that shows real daily temperature profiles throughout the DSF, real air movement by arrows that track real smoke test paths, and also specific

indicators of where the sensors collected the temperature and humidity data.

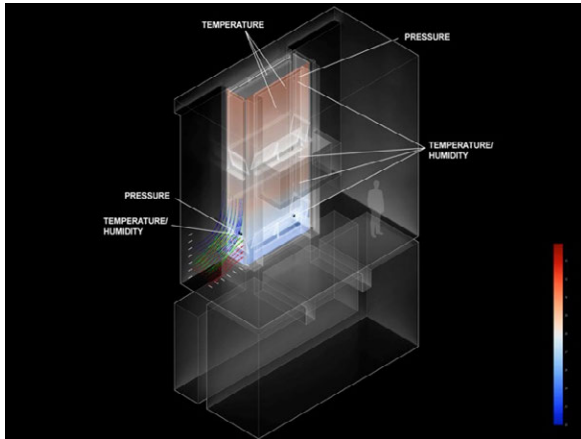

*Fig. 10: Air flow and air temperature depiction informed with real data.*

The authors would like future depictions of the space to include probabilistic operation as well, i.e. an element of the image that represents the likelihood of the air throughput being sufficient throughout the day. This could be informed partially by the time derivative shown in fig. 7b, however this must be part of a future investigation.

## 5 ACKNOWLEDGMENTS

Thanks to Princeton Facilities for access and permissions for data collection, and to Harrison Fraker and Lawrence Lindsey for providing historical context.

## 6 REFERENCES

1. Fowler, K et al. "Re-assessing green building performance: A post occupancy evaluation of 22 GSA buildings." Pacific Northwest National Laboratory: Richland, WA, USA (2011).
2. Raman, Mahadev et al. "Visualizing the Flow." Civil Engineering—ASCE 66.6 (1996): 43-45.





## UNCERTAINTY AND SENSITIVITY ANALYSIS FOR THE OPTIMAL DESIGN OF DISTRIBUTED URBAN ENERGY SYSTEMS

G. Mavromatidis<sup>1,2\*</sup>, K. Orehounig<sup>1,2</sup>, J. Carmeliet<sup>1,3</sup>

<sup>1</sup> Chair of Building Physics, Swiss Federal Institute of Technology Zurich, Switzerland

<sup>2</sup> Laboratory for Urban Energy Systems, Swiss Federal Laboratories for Materials Science and Technology, EMPA, Duebendorf, Switzerland

<sup>3</sup> Laboratory for Multiscale Studies in Building Physics, Swiss Federal Laboratories for Materials Science and Technology, EMPA, Duebendorf, Switzerland

\*Corresponding author; e-mail: mavromatidis@arch.ethz.ch

### Abstract

Deterministic model-based design of energy systems assumes perfect knowledge for all the model input parameters. Such a practice entails the risk of sub-optimal designs due to uncertainty that could cause model parameters to deviate from their original values. Thus, the first step towards designing a robust energy system should be understanding uncertainty's effects and its main drivers. Such investigations are facilitated by using uncertainty and sensitivity analysis. In this paper, an uncertainty quantification workflow is presented using the energy hub concept as the computational model. Initially, a characterization of uncertain input parameters is outlined pertaining to the buildings' energy demands, and the hub's technical and economic aspects. Subsequently, Uncertainty Analysis (UA) is performed by propagating the inputs' uncertainty through the model in a Monte Carlo fashion to study how the model's output is affected. Finally, Sensitivity Analysis (SA) is performed using the *Morris method* to screen out unimportant parameters and *Variance-based SA* to quantify the contribution of input parameters to the output's variance. The framework is illustrated with a case study, a residential urban neighbourhood for which an energy system is designed. The output of this paper allows us to test the model's robustness, understand the extent to which uncertainty actually matters by examining how much the model output varies compared to the deterministic case, and understand the influence and the interactions between the parameters of the model.

### Keywords:

Uncertainty analysis; Global sensitivity analysis; Energy hub; Monte Carlo; Urban energy systems

## 1 INTRODUCTION

### 1.1 Distributed energy systems (DES) and uncertainty

DES are expected to be a core component of future urban energy systems incorporating a multitude of generation and storage technologies that supply the energy needs of multiple buildings. The challenge to optimally design and operate DES relies heavily on modelling; however, as with any numerical modelling effort, models for the optimal DES design are irrevocably affected by uncertainty. Human behaviour and the uncertain future global economic and energy outlook are a

subset of factors that can introduce uncertainty to a DES model.

Nonetheless, designers usually assume perfect knowledge of all the model input parameters, reducing an inherently uncertain problem to a deterministic one. This practice entails the risk of suboptimal designs leading to excess costs and/or carbon emissions, but also to more adverse consequences like disruptions of service and the failure to satisfy building energy demands.

In the literature, the issue of uncertainty in DES has been widely recognized, resulting in many studies applying uncertainty analysis (UA) and

sensitivity analysis (SA) to investigate uncertainty's impacts on design and operational aspects of DES, e.g. [1-8].

A shortfall of these studies, though, is that, in some cases, the focus is placed only on single uncertain parameter categories, like energy prices (e.g. [8]) or energy demands (e.g. [1]). Also, while other studies focus on more parameters, they exclude others that could influence the design and operation of a system. For instance, Ren et al. [5] investigate several factors excluding, though, energy demand uncertainty from their study.

An additional shortfall of previously published studies is that they employ local SA techniques (e.g. [2-7]). In these methods, one-at-a-time (OAT) sampling varies one uncertain parameter, while all the other parameters are fixed. Even though, such an approach is easy to implement and understand, it only explores a limited part of the input space. In contrast, global SA techniques investigate the effect of a parameter while all the other parameters are varied as well over their entire range, allowing the interactions between parameters to be studied.

Therefore, the goal of this paper is twofold: first, to present a structured procedure that considers and characterizes the uncertainty of all parameter types involved in the model, and second, to illustrate the use of UA and Global SA for the investigation of the influence of model parameter uncertainties on the model's behaviour and the identification of the most influencing parameters.

## 2 MODELLING FRAMEWORK

### 2.1 Energy hub model

In this work, the energy hub concept [9] is applied at the urban level to design energy systems that meet buildings' thermal and electrical energy requirements. The model uses optimization techniques to select the installed components and their capacities, considering their optimal operating schedule, while optimizing for a desired objective. The minimisation criterion in this work is the equivalent annual cost (EAC) composed of the operating cost of the energy system plus the amortised investment cost of the units minus any revenue due to electricity exports.

The candidate technologies considered can be seen in Fig. 1 and include: a natural gas powered boiler and a CHP engine, an air-source heat pump (ASHP), photovoltaic (PV) panels, a sensible thermal storage tank and batteries. Grid imports and exports of surplus electricity are also enabled in the model. All technologies are assumed to be installed centrally, supplying energy to the buildings via small scale networks, except for PV panels that are distributed to the building roofs.

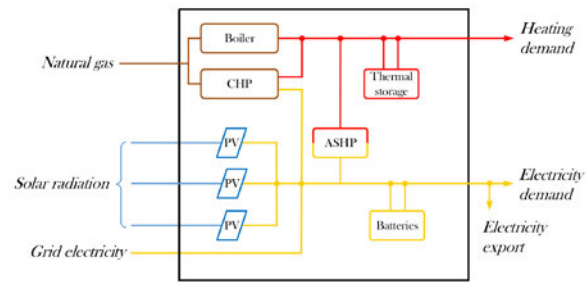

Fig. 1: Energy hub representation of the urban energy system.

The mathematical formulation of the energy hub model follows closely the ones used by preceding papers, such as [10-12], and it is a mixed-integer linear program (MILP). The MILP formulation is shown in pseudocode in Fig. 2.

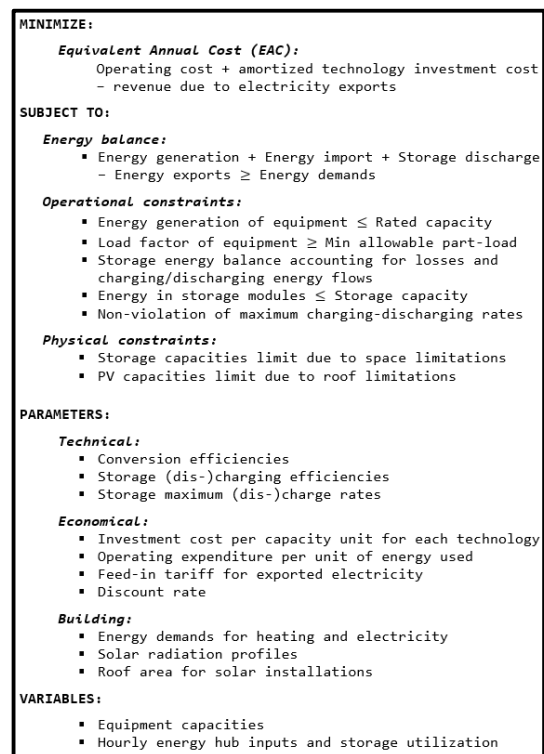

Fig. 2: MILP formulation for the energy hub.

### 2.2 Uncertainty characterisation (UC)

The first and most important step to investigate uncertainty is to characterise all its sources in the model and assign a mathematical representation to their uncertainty. In this work, sources from the literature are mainly used to perform this task.

In an energy hub model, uncertainty can affect economic and technical parameters as well as the solar radiation and energy demand profiles at the output of the hub. Regarding cost parameters, the uncertainty for the electricity and gas prices, as well as the feed-in tariff for exported electricity is assigned a uniform distribution allowing a  $\pm 15\%$  deviation from the nominal value [13], while for the investment costs, a similar distribution is selected with a range of  $\pm 30\%$  [13].

Deterministic design considers the technical characteristics of equipment constant throughout their lifetime. However, factors like poor commissioning, ineffective maintenance, and wear and tear can lead to performance deterioration, the extent of which is unknown. To represent, the probability of fainting performance, similarly to [14], a one-sided normal distribution is selected that enables random deviation of maximum -15% from the nominal characteristics.

However, a different approach is needed for the uncertainty of the energy demands as, on the one hand, they are not scalar parameters but time series, and on the other hand, they are calculated as the output of a Building Performance Simulation (BPS) model. In this case, *the inputs of a BPS model* are deemed as uncertain and their uncertainty is propagated through the BPS model to obtain variable demand profiles. A description of these uncertainties is as follows:

Variations in the building material properties, like density, conductivity and thermal capacity are assigned a normal distribution [15], the indoor temperature set-point of each building is varied following a normal distribution, while a triangular distribution has been selected for the occupant density ( $\text{m}^2/\text{person}$ ) and the lighting and appliances density ( $\text{W}/\text{m}^2$ ) [16]. Additionally, a normal distribution is attributed to the per person ventilation rate of each building, as well as to the infiltration rate [15].

Variation to the nominal yearly schedules for building occupancy, lighting, and appliances usage is also introduced in two ways. First, each value of the yearly schedules is randomly varied by  $\pm 15\%$  around its nominal value (“vertical” variability). Then, we proceed to define blocks of hourly periods for the 24 h of each day (e.g. [00:00–06:00], [07:00–09:00], etc.) and within these blocks shuffling the schedules values with each other (“horizontal” variability). This approach allows us to maintain the order of actions causing specific energy patterns (e.g. processes happening in the morning versus processes happening at noon) while introducing some randomness within the blocks [17].

Finally, weather uncertainty is treated by using Actual Meteorological Years (AMY) for the period 1994–2013 built with data from Meteoschweiz [18]. This approach also allows us to characterise uncertainty of incoming solar radiation by using directly the solar patterns from the weather files.

In order to treat energy demands as a random variable, first, a series of 1000 demand profiles are calculated per building and aggregated to form the neighbourhood’s total demand. These aggregated profiles are then sorted based on their total yearly demand meaning that demand profile “1” is the one that corresponds to the smallest aggregated demand, while profile “1000” to the largest. These profiles are then treated like a discrete uniform

distribution at the range [1,1000] from which random demand profiles can be sampled.

### 2.3 Uncertainty analysis (UA)

Uncertainty analysis is the study of how the uncertainty in the model’s inputs affects the variability of the model’s outputs. In this work, a Monte Carlo method is used that starts by generating a sample from each input parameter distribution, e.g. of size  $N$ , and then evaluates the model  $N$  times, producing an *input-output map*. The  $N$  output values can be used to study the uncertainty in the output, create histograms and calculate statistical moments.

### 2.4 Sensitivity analysis (SA)

Sensitivity analysis (SA) is a related technique to UA, with a definition for it by Saltelli et al. [19] as: “*The study of how uncertainty in the output of a model can be apportioned to different sources of uncertainty in the model input*”. The SA technique selected in this work is based on the decomposition of the model’s output variance. The goal is to calculate two quantitative sensitivity measures of the contribution of each input to the unconditional variance of the output [20]. The first, named the *first-order Sobol index*  $S_i$ , indicates the portion of the output variance  $V(Y)$  that can be attributed to the  $i$ th input  $X_i$  and is defined as:

$$S_i = V_{X_i}(E_{X_{-i}}(Y|X_i))/V(Y) \quad (1)$$

where  $X_{-i}$  denotes the matrix of all input factors but  $X_i$ . However,  $S_i$  does not take into account the interaction between parameters. Two (or more) parameters are said to be interacting when their joint effect on the output is different from the sum of their individual effects. Therefore, the *total-order Sobol index*  $S_{Ti}$  is defined that corresponds to the portion of  $V(Y)$  attributable to all the effects of  $x_i$  and is defined as:

$$S_{Ti} = E_{X_{-i}}(V_{X_i}(Y|X_{-i}))/V(Y) \quad (2)$$

One advantage of variance-based methods is that they do not require any assumption for the model form such as linearity or monotonicity. Their drawback, though, is their high computational cost requiring  $n(p+2)$ ,  $n \cong 500\text{--}1000$  model runs [21] for  $p$  uncertain parameters. Therefore, it would be computationally prohibitive to consider a variance-based method with the complete portfolio of uncertain parameters due to their number, as in this case  $p$  is equal to 17.

A common approach in this case is to use a screening method to identify non-influential parameters with a small number of model calls [22]. The most popular screening technique is the one introduced by Morris [23–24]. The method of Morris is based on a discretisation of the input space and performs a series of OAT experiments with the variation direction being random. The main output metric of the Morris method for each uncertain parameter are the mean  $\mu$  which is a measure of the overall influence of the factor on the output, and the standard deviation  $\sigma$  which

indicates if the factor is interacting with other factors or if it has nonlinear effects on the output.

The method's main drawback is that its result can only be interpreted qualitatively. Nevertheless, the Morris method output allows us to fix non-influential parameters to their nominal values, and proceed to calculate the Sobol indices and obtain quantitative results only for the influential ones. Further details on the mathematical aspects of the SA methods can be found in [21-24].

### 3 CASE STUDY

To illustrate the developed framework, a case study is selected consisting of three residential buildings of various construction periods, for which an energy system is to be designed. The buildings' construction characteristics follow the ones in [25]. Nominal values for occupancy, internal gains, heating set points and the schedules for occupancy and appliances/lighting usage are taken from SIA 2024 [26]. The building energy demands are calculated using *EnergyPlus* with a Typical Meteorological Year (TMY) for the climate of Zurich, Switzerland used for the deterministic design. An illustration of the three buildings is shown in Fig. 3.

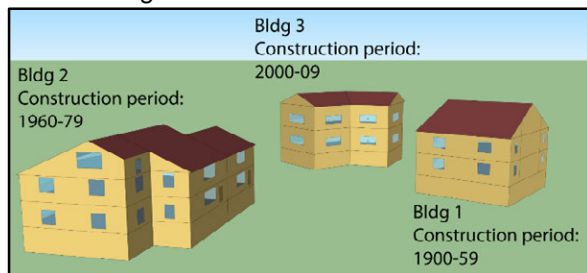

Fig. 3: Illustration of buildings composing the case study residential neighbourhood.

## 4 RESULTS

### 4.1 Deterministic model results

Before assessing the effects of uncertainty, the results of the deterministic version of the model are presented to be used as the comparison basis. The deterministic annual and peak building energy demands that are given as input to the model are presented in Table 1.

Bldg	Area (m <sup>2</sup> )	Annual demand (kWh/m <sup>2</sup> )		Peak demand (kW)	
		Heat	Elec.	Heat	Elec.
1	510	108	45	34	8
2	766	58	43	35	11
3	363	39	35	15	5
Sum	1639	69	42	79	24

Table 1: Annual total and peak energy demand for each building and for the whole neighbourhood.

The optimal energy hub design, in this case, consists of a heat pump, a CHP engine and a thermal storage module with their capacities shown in Table 2. The EAC in this case is equal to 26,280 CHF. The deterministic design excludes the installation of PV panels, batteries and boilers.

System components	Capacity
CHP	30 kW <sub>th</sub> /19 kW <sub>el</sub>
ASHP	22 kW
Thermal storage	88 kWh
Total cost	26,280 CHF

Table 2: Optimal energy hub design and EAC for the deterministic case.

### 4.2 Uncertainty analysis results

Similarly to the previous section, the first reported results are the variable energy demands of the buildings. As was mentioned in Section 2.2, variable demand profiles for each building are calculated by propagating the uncertain inputs of the BPS models through the model, with the results shown in Fig. 4

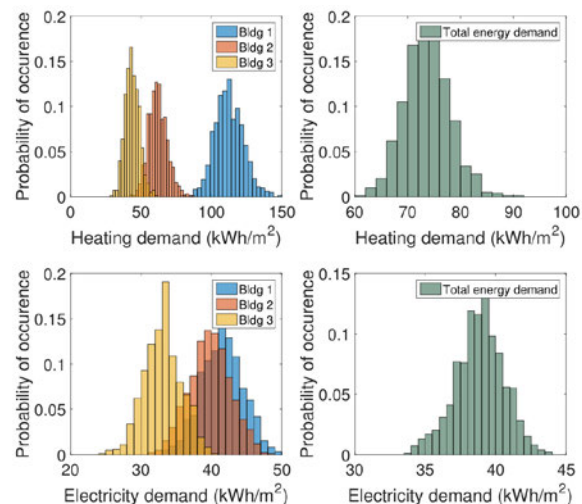

Fig. 4: Histograms of heating and electricity demand for the individual buildings and the whole neighbourhood.

Knowing the variation of the buildings' energy demands, the next step is to perform UA on the energy hub model by sampling from the set of uncertain parameter distributions. In total, 2'000 runs of the energy hub model are executed, and Fig. 5 shows the variation of the EAC in terms of its probability density function (PDF) and its cumulative distribution function (CDF). It can be seen that the energy system's optimal cost can vary from values that are lower than the deterministic EAC to values that are higher. In fact, there is approx. 60% probability that the cost will be exceeded as can be deduced from the CDF.



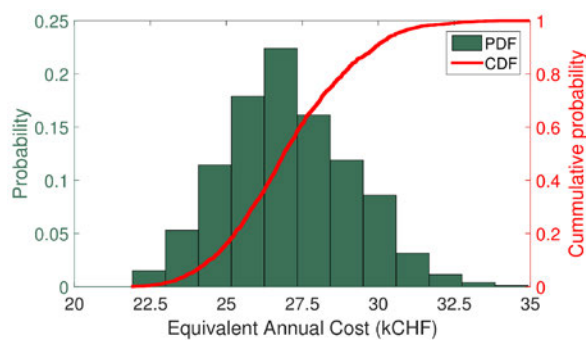

Fig. 5: Probability density function (PDF) and Cumulative distribution function (CDF) for the EAC of the energy hub under uncertainty.

Apart from the annualised cost, the variation of the optimal energy hub design for each of the 2,000 Monte Carlo runs is shown in Fig. 6. Each run is depicted as a semi-transparent line enabling a better visualisation of the areas where there is higher density of optimal designs.

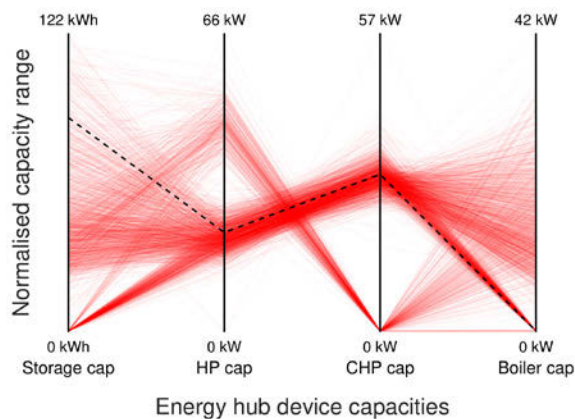

Fig. 6: Parallel coordinates plot showing the resulting optimal system capacities of 2000 runs of the energy hub model. The dashed line corresponds to the deterministic design.

PV and electrical storage are not included as in none of the 2'000 runs were they selected (due to the lack of any emission performance criterion), thus, the design was limited to a selection of four components. Starting from the thermal storage there is a number of designs that do not include it, while in the cases that do include it, the optimal capacity seems to vary considerably. On the other hand, it seems that for both the ASHP and the CHP engine there are two regions where the optimal capacities are clustered. Additionally, it is seen that when a high capacity for the HP is selected the design excludes the CHP engine completely, while when the low HP capacity is opted for, the CHP engine is present at a higher capacity. Finally, with regards to the boiler, a similar situation as with the thermal storage is observed with some designs omitting it completely, while when present its capacity is not clustered around a specific region. The implications of this analysis are twofold. On the

one hand, the optimal design of the energy system would be different depending on the actual realisation of the uncertain parameters; hence, the fact that uncertainty has an impact is indeed confirmed. In addition, for every Monte Carlo run that the optimal design is different than the deterministic one, it means that the latter design is suboptimal (otherwise the algorithm would have selected the deterministic design as the optimal one). This fact could mean that the deterministic design will lead to higher costs due to its suboptimality and that there is a probability that some portion of the energy demand will be unmet due to a shortage of essential generation capacity.

### 4.3 Sensitivity analysis results

The previous section revealed the effects of uncertainty on both the system's cost and its design aspects. In this section, we try to connect the output uncertainty to the inputs and determine which are the most responsible for this variability. First, a qualitative assessment is performed using the Morris method, with results shown in Fig. 7.

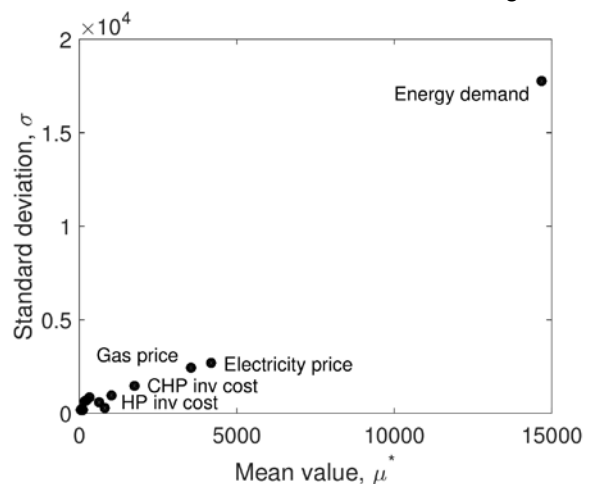

Fig. 7: Outputs from the Morris method showing  $\mu$  and  $\sigma$  for each uncertain parameter. The 5 most influencing parameters have been labelled.

The most important parameter is the energy demands of the buildings, followed by the operating cost parameters, for both gas and electricity. Finally, as the main dominating technologies that are installed in the energy hub, the investment cost for the HP and the CHP engine are also deemed important. The results would also imply that all the other parameters of the model, such as the remaining investment cost parameters and all the technical characteristics can be considered less important and, thus, can be fixed to their nominal values.

As the results of the Morris analysis can only be interpreted qualitatively, quantitative information can be obtained by calculating the Sobol indices for the 5 most important parameters. Having a set of 5 important parameters from the preceding section, the required number of computations is equal to  $1000 \times (5+2) = 7,000$  simulations, as

defined in Section 2.4. The results are shown in Fig. 8.

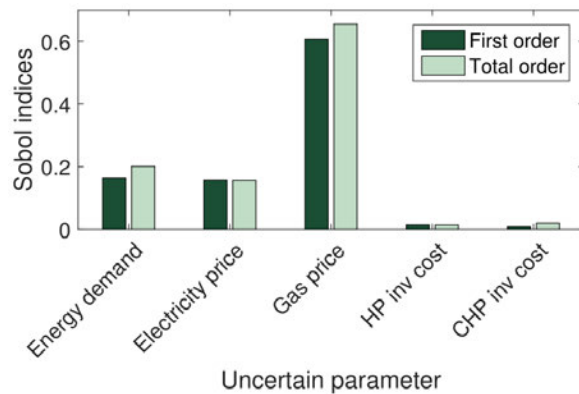

Fig. 8: First- and total-order Sobol indices for the most influencing parameters of the energy hub model.

The order of importance among the parameters, as evidenced by both Sobol indices includes the gas price as the most important parameter, followed by the energy demands and the electricity price in close proximity. On the other hand, investment cost parameters seem to be the least influencing, which is to be expected as over the lifetime of the project, operating expenditure tends to occupy a much higher portion of the total cost compared to the investment expenditure. Finally, the small differences between  $S_i$  and  $S_{Ti}$  show that the model is mainly dominated by first-order effects. More specifically, the sum of the first-order indices indicates that 95% of the output's variance is attributed to first-order effects, with only the remaining 5% being due to higher order effects.

As is obvious, the results of a SA are case specific and in this case the large influence of the gas price can be expected due to the dominance of gas powered technologies in the optimal energy system configurations. The results of such a study, though, are very useful in the planning phase of a system because they allow the designer to identify the most influencing parameters whose uncertainty if reduced will lead to the greatest reduction of the cost's variability.

## 5 CONCLUSIONS

In this paper, a multi-step workflow has been presented to investigate uncertainty in the context of urban DES design and its application is illustrated with the design of an energy system for a residential neighbourhood.

Starting from a deterministic energy hub model, a detailed characterisation of the uncertainty sources in the model has been performed. Performing UA in the planning phase of an energy system by propagating the input parameter uncertainty through the model has revealed the influence of uncertainty on the optimal system

cost, as well as the system's structure and size. Finally, further investigation using SA has narrowed down the most important input parameters, showing that the variation of the system's cost is predominantly due to the uncertainty in the gas prices.

In terms of future work, the first step will be to extend the framework to include additional objectives, such as the minimisation of carbon emissions and/or primary energy in order to investigate the variation with regards to these domains. Additionally, the paper's outcome will be used as the basis for studies that use stochastic programming seeking to obtain a *single system design* that will operate optimally under all realisations of uncertainty by showcasing the most important parameters to be used for the scenario generation.

## 6 ACKNOWLEDGEMENTS

Research presented in this paper is supported by funds from CCEM (IDEAS4cities project) and Swiss Competence Centres for Energy Research (SCCER) Future Energy Efficient Buildings & Districts (FEEB&D) (KTI.2014.0119). The authors would also like to thank Parag Rastogi for his kind provision of the AMY for the climate of Zurich and Raphael Wu for his help with the EnergyPlus models.

## 7 REFERENCES

- Li, C.Z., Shi, Y.M., Huang, X.H. (2008) Sensitivity analysis of energy demands on performance of CCHP system, *Energy Conversion and Management* 49, 3491–3497.
- Yoshida, S., Ito, K., Yokoyama, R. (2007) Sensitivity analysis in structure optimization of energy supply systems for a hospital, *Energy Conversion and Management* 48, 2836–2843.
- Mehleri, E.D., Sarimveis, H., Markatos, N.C., Papageorgiou, L.G. (2013) Optimal design and operation of distributed energy systems: Application to Greek residential sector, *Renewable Energy* 51, 331–342.
- Ashouri, A., Petrini, F., Bornatico, R., Benz, M.J. (2014) Sensitivity analysis for robust design of building energy systems, *Energy* 76, 264–275.
- Ren, H., Zhou, W., Gao, W. (2012) Optimal option of distributed energy systems for building complexes in different climate zones in China, *Applied Energy* 91, 156–165.
- Li, H., Nalim, R., Haldi, P.A. (2006) Thermal-economic optimization of a distributed multi-generation energy system—A case study of Beijing, *Applied Thermal Engineering* 26, 709–719.

7. Ren, H., Gao, W., Ruan, Y. (2008) Optimal sizing for residential CHP system, *Applied Thermal Engineering* 28, 514–523.
8. Kienzle, F., Ahcin, P., Andersson, G. (2011) Valuing Investments in Multi-Energy Conversion, Storage, and Demand-Side Management Systems Under Uncertainty, *IEEE Transactions on Sustainable Energy* 2, 194–202.
9. Geidl, M. (2007) Integrated modeling and optimization of multi-carrier energy systems, PhD Thesis, ETH Zurich.
10. Mavromatidis, G., Evins, R., Orehounig, K., Dorer, V., Carmeliet, J. (2014) Multi-objective optimization to simultaneously address energy hub layout, sizing and scheduling using a linear formulation, In: *ENGOPT 2014*, Lisbon, Portugal, September 8th – 11th 2014
11. Orehounig, K., Evins, R., Dorer, V. (2015) Integration of decentralized energy systems in neighbourhoods using the energy hub approach, *Applied Energy* 154, 277–289.
12. Evins, R., Orehounig, K., Dorer, V., Carmeliet, J. (2014) New formulations of the “energy hub” model to address operational constraints, *Energy* 73, 387–398.
13. Fazlollahi, S. (2014) Decomposition optimization strategy for the design and operation of district energy systems, PhD thesis, EPFL Lausanne.
14. Giannakoudis, G., Papadopoulos, A.I., Seferlis, P., Voutetakis, S. (2010) On the Systematic Design and Optimization under Uncertainty of a Hybrid Power Generation System Using Renewable Energy Sources and Hydrogen Storage, *Computer Aided Chemical Engineering* 28, 907–912.
15. Macdonald, I., Strachan, P. (2001) Practical application of uncertainty analysis, *Energy and Buildings* 33, 219–227.
16. Gang, W., Wang, S., Shan, K., Gao, D. (2015) Impacts of cooling load calculation uncertainties on the design optimization of building cooling systems, *Energy and Buildings* 94, 1–9.
17. Mavromatidis, G., Orehounig, K., Carmeliet, J. (2015) Evaluation of photovoltaic integration potential in a village, *Solar Energy* 121, 152–168.
18. MeteoSwiss (2016) Federal Office of Meteorology and Climatology MeteoSwiss. Available from: <http://www.meteoswiss.admin.ch/>
19. Saltelli, A. (Ed.) (2004) *Sensitivity analysis in practice: a guide to assessing scientific models*. Wiley, Hoboken, NJ.
20. Eikos (2012) *Eikos Sensitivity Analysis Toolbox*, Facilia AB, Bromma, Sweden
21. Saltelli, A. (Ed.) (2008) *Global sensitivity analysis: the primer*. John Wiley, Chichester, England; Hoboken, NJ.
22. Iooss, B., Lemaitre, P. (2015) A Review on Global Sensitivity Analysis Methods, in: Dellino, G., Meloni, C. (Eds.), *Uncertainty Management in Simulation-Optimization of Complex Systems*. Springer US, Boston, MA, pp. 101–122.
23. Morris, M.D. (1991) Factorial Sampling Plans for Preliminary Computational Experiments, *Technometrics* 33, 161–174.
24. Campolongo, F., Cariboni, J., Saltelli, A., 2007. An effective screening design for sensitivity analysis of large models. *Environmental Modelling & Software* 22, 1509–1518.
25. Orehounig, K., Mavromatidis, G., Evins, R., Dorer, V., Carmeliet, J. (2014) Towards an energy sustainable community: An energy system analysis for a village in Switzerland, *Energy and Buildings* 84, 277–286.
26. SIA (2006) *Standard-Nutzungsbedingungen für Energie und Gebäudetechnik*. Schweizerischer Ingenieur und Architektenverein, Switzerland.





## Expanding Boundaries: Systems Thinking for the Built Environment

### DOES ROOF SHAPE MATTER? SOLAR PV INTEGRATION ON ROOFS

N. Mohajeri<sup>1\*</sup>, D. Assouline<sup>1</sup>, B. Guiboud<sup>1</sup>, J.L. Scartezzini<sup>1</sup>

<sup>1</sup>Solar Energy and Building Physics Laboratory (LESO-PB), Ecole Polytechnique  
Fédérale de Lausanne (EPFL), 1015 Lausanne, Switzerland

\*Corresponding author; e-mail: mohajeri.nahid@epfl.ch

#### Abstract

This paper focuses on roof-shape classifications and solar potential for integrating photovoltaics (PV) on roofs. A machine-learning approach, Support Vector Machine (SVM), is used to classify the roof shapes in the city of Geneva. The impact of various roof characteristics on the solar potential is assessed and analysed. Monthly solar irradiation on rooftops, freely accessible from [www.ge.ch/sitg](http://www.ge.ch/sitg) using GIS LiDAR data (resolution 50cm by 50cm), is used in the analysis. The SVM identifies 6 types of roof shapes correctly in 66% of cases, that is, flat, gable, hip, gambrel & mansard, cross/corner gable & hip, and complex roof. We rank the roofs based on the complexity of their shape, useful area for PV, and potential for receiving solar energy. The results show that for most roof shapes the ratio between useful roof areas and the building footprint area is close to one, the main exception being gable where the ratio is 1.18, suggesting that the footprint is a good measure of useful PV roof area. The flat roof has the second highest useful roof area for PV (the complex roof being the highest) and the highest PV potential (in GWh). By contrast, hip roof has the lowest PV potential. Solar roof-shape classification provides basic information for designing new buildings, retrofitting interventions on the building roofs and efficient solar integration on rooftops. The results for the city of Geneva suggest that a data-driven approach is very useful for roof-shape classifications which can be expanded to national scale.

#### Keywords:

Machine learning; Roof-shape classification; Solar potential; Support Vector Machine

### 1 INTRODUCTION

There have been several studies focusing on the modelling of rooftop solar potential at neighbourhood and urban scale using different methods. For example, Wiginton et al. [1] use the sampling technique as well as the GIS-based Feature Analyst (FA) tool to estimate the rooftop PV potential. Nowak et al. [2] use statistical methods to estimate the solar PV potential for building roofs and facades at the national scale. Several other studies use aerial images and ArcGIS LiDAR data to determine roof geometries and to estimate the PV potential at a large scale [3, 4, 5, 6, 7, 8]. By contrast, Assouline et al. [9] use a machine learning approach to estimate the building rooftop solar PV potential for Switzerland. Other recent studies on modelling roof geometries for solar applications based on a simplification of roofs include the following [10, 11]. However, the classification of roof shapes

(e.g. flat, gable, shed, hip), that is, roof architecture in relation to their solar potential has, so far, received little attention. In this paper, we focus on the city of Geneva as a case study, due to the availability of high resolution GIS data for roof geometries. The city of Geneva is composed of 16 neighbourhoods with a total of about 11,400 buildings (Fig. 1). The total area of the city is about 16 km<sup>2</sup> with a population density of 12,000 per km<sup>2</sup>. About 92% of the total land in the city is used for built-up area, of which about 50% are buildings.

The main aim of this paper is to apply a data-driven methodology for classifying different roof shapes in relation to their potential for receiving solar energy.

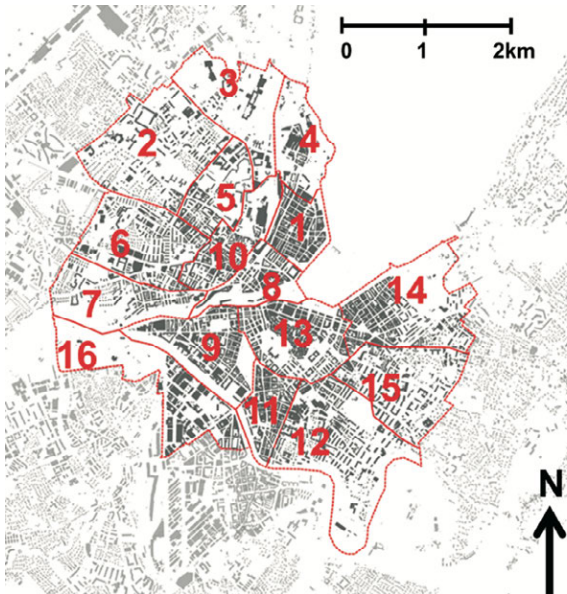

Fig. 1: Building map of the city of Geneva, composed of 16 neighbourhoods, each one marked by red broken line.

## 2 METHODOLOGY

To classify the building roofs in the Geneva city according to their shapes, GIS and Machine Learning algorithms have been used. Support Vector Machines (SVM) is one of the most efficient machine learning algorithms for classification tasks. It was initially developed by Cortes and Vapnik in 1995 [12]. The following section gives a short description of the main principles of the algorithm. This is followed by a section on the application of the method for classifying the roof shapes in the city of Geneva.

### 2.1 Support Vector Machine (SVM) Model

The Support Vector Machines (SVMs) are primarily an example of a linear classifier [12, 13, 14]. They can, however, be extended to non-linear classifier with kernel functions. SVM is a machine learning technique based on the concept of decision planes (hyperplanes) which define the decision boundary of the classifier. A classifier separates a set of objects into their respective classes with a line. A hyperplane is optimal if it maximizes the margin of separation between the two classes. Some objects may not be linearly separable. For these, a non-linear classifier is defined. To move from a linear classifier to a non-linear classifier, a set of mathematical functions known as kernels is defined. The performance of SVM depends heavily on the choice of the kernel function,  $K(x_i, x_j)$ . There are number of kernels that can be used in Support Vector Machines models. These include linear, polynomial, radial basis function (RBF), and sigmoid. The RBF is by far the most popular choice of kernel types used in

Support Vector Machines. The following is the Gaussian radial basis function:

$$K(x_i, x_j) = \exp\left(-\gamma|x_i - x_j|^2\right) \quad (1)$$

where  $\gamma > 0$  is a parameter that controls the width of Gaussian kernel function. It plays a similar role as the degree of the polynomial kernel in controlling the flexibility of the resulting classifier. Using the kernel function, we implicitly map the input data to a so-called feature space, where the function can be modelled as a linear function. We compute the following Eq. (2):

$$K(x_i, x_j) = \langle \phi(x_i), \phi(x_j) \rangle \quad (2)$$

where  $K(x_i, x_j)$  is the kernel function and  $\phi$  is mapping from the original input space to the feature space. As mentioned, Support Vector Machine (SVM) is primarily a classification method that separates objects of different classes by constructing hyperplanes in a multidimensional space. To construct an optimal hyperplane, SVM employs an iterative training algorithm, which is used to minimize a function. Depending on the error function, SVM models can be used for classification or regression. Minimizing the error function while training the data, leads to the following constrained optimization problem [12, 13, 14]:

$$\text{Minimize} \quad \frac{1}{2} \|w\|^2 + C \sum_{i=1}^N \xi_i \quad C > 0 \quad (3)$$

Subject to:

$$y_i (\langle w, x_i \rangle + b) \geq 1 - \xi_i \quad \text{and} \quad \xi_i \geq 0, i = 1, \dots, N$$

where  $C$  is the capacity constant, a tuning parameter, which controls errors and thus controls the generalization ability of an SVM.  $w$  is the weight vector, that is, an unknown vector to be optimised,  $b$  is a constant, and  $\xi_i$  is slack variable so as to deal with the outliers.  $x_i$  is the training vector, so the index  $i$  labels the  $N$  training samples that are mapped into a higher dimensional space by the function  $\phi$ . It should be noted that the larger the  $C$ , the more the error is penalized. Thus,  $C$  should be chosen with care to avoid over fitting. By choosing a low  $C$ , the risk of overfitting an SVM on the training sample is reduced. Before applying the methodology for roof-shape classification, several roof-shape characteristics have been analysed in the next section.

### 3 ANALYSING ROOF CHARACTERISTICS

We analyse the roof characteristics including roof orientation, roof aspect, and roof slope for the all the buildings in the city of Geneva (Figs. 2, 3). Yearly and monthly solar irradiation for roofs has been estimated using GIS LiDAR data ([www.ge.ch/sitg/](http://www.ge.ch/sitg/)) and is freely accessible. Fig. 2a shows the distribution of roof tilted-angles.

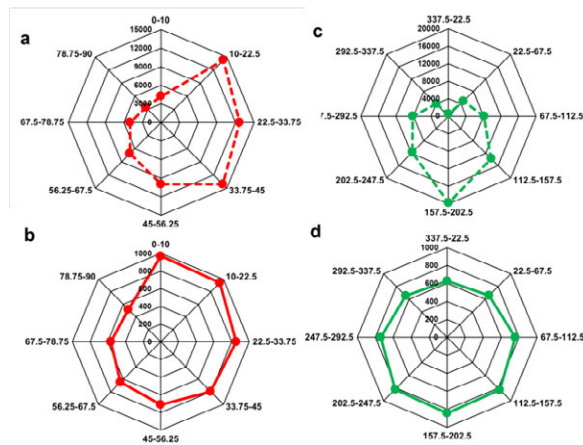

Fig. 2: Frequency distribution of different roof slopes and roof aspects (a, c). Yearly mean solar irradiation,  $\text{kWh/m}^2$ , for different aspect and slope ranges (b, d).

The highest frequency belongs to roofs with the slope between 10 degrees and 45 degrees. The lowest frequency belongs to buildings with a 0 to 10 degrees slope (flat roofs). Regarding the roof aspects (the direction in which a roof faces), those roofs that are facing to the south-east, south, and south-west have the highest frequency (Fig. 2c). We use the estimated yearly solar irradiation for rooftops ([www.ge.ch/sitg/](http://www.ge.ch/sitg/)) in order to analyse the solar potentials in relation to slope range and aspect range. Figs. 2b shows that while the flat roofs (0-10 degrees slope) have the lowest frequency they receive the highest solar irradiation. The second highest solar irradiation belongs to roofs with slopes between 10 to 45 degrees. Fig. 2d shows that roofs facing to south-east, south, and south-west receive the highest solar irradiation. Whereas roofs facing to the north, north-east, and north-west receive comparatively little solar irradiation. The roof orientation is thus a very important roof characteristic (Fig. 3).

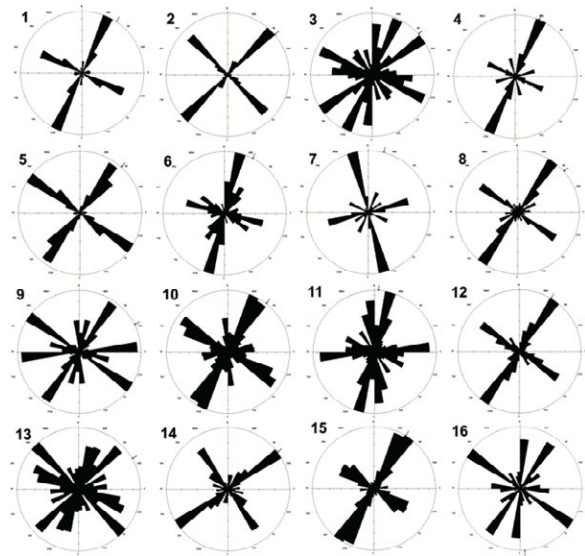

Fig. 3 Frequency distribution of roof orientations for the 16 neighbourhoods shown in Fig. 1

We use circular statistics visualized by rose diagrams to show the orientation of roofs in the city of Geneva. To understand better the distribution of roof orientations, we divide the city into 16 neighbourhoods and for each neighbourhood the roof orientations have been plotted using a rose diagram (Fig. 3). The rose diagrams show that for most of the neighbourhoods roofs trending south-west and north-east have the highest frequency (number 1, 2, 4, 6, 8, 10, 11, 12, 14, 15). For several neighbourhoods (3, 9, 13, 16) the rose diagrams show a circular distribution indicating that roofs trending in all directions.

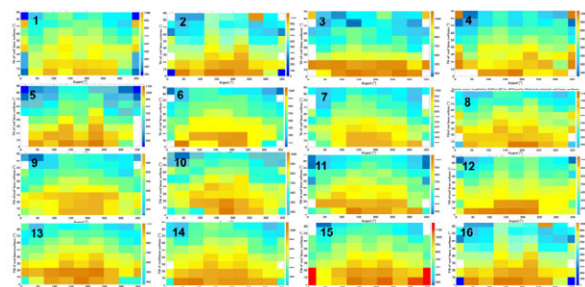

Fig. 4. Yearly mean solar irradiation [ $\text{kWh/m}^2$  year] as a function of the slope  $[0-90^\circ]$  (y-axis) and aspect  $[0-360^\circ]$  (x-axis) of the roof surfaces for the 16 neighbourhoods.

For each neighbourhood we use MATLAB in order to create 3D plot of solar irradiation, roof aspect, and roof slope (Fig. 4). For all the neighbourhoods, we find that the yearly mean solar irradiation ( $\text{kWh/m}^2$ ) varies depending on roof slopes and roof aspects. However, the highest solar irradiation belongs to roof slopes between  $0 - 30$  degrees and roof aspects between south-east and south-west. Combining all the neighbourhoods, we plot yearly mean solar irradiation [ $\text{kWh/m}^2$ ], for all the roof surfaces in the city of Geneva, as a function of roof slope and roof aspect (Fig. 5). The results are consistent with the neighbourhood results and show that the highest solar irradiation belongs to slopes  $0-30^\circ$  and roof aspects  $112.5^\circ-247.5^\circ$ .

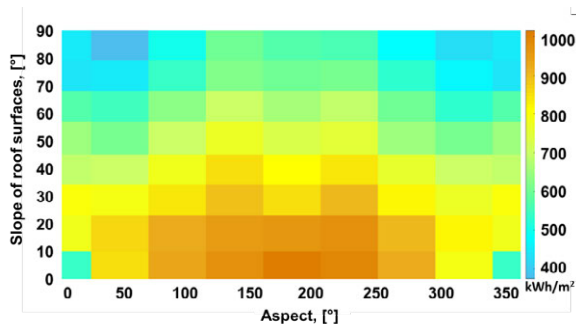

Fig. 5: Yearly mean solar irradiation [ $\text{kWh/m}^2$  year] as a function of the slope [ $0-90^\circ$ ] (y-axis) and aspect [ $0-360^\circ$ ] (x-axis) of the roof surfaces for the city of Geneva.

#### 4 SUPPORT VECTOR MACHINE (SVM) FOR ROOF CLASSIFICATION

The total number of buildings chosen and classified for this study of the city of Geneva is 11,400. The most common roof shapes of buildings in Geneva are flat, shed, gabled, hipped, gambrel, mansard flat, mansard hipped, cross-hipped, cross-gabled, corner-hipped, corner-gabled, pyramidal, and complex (mixed of several mentioned roof shapes). Some of these roof shapes, however, are difficult to classify properly and use. For the present purpose the above roof shapes have been divided into 6 main groups, namely flat, gabled, hipped, gambrel and mansard, cross/corner hipped and gabled, and complex. In order to apply SVM for classification of roof shapes, the following steps are taken:

**(i) Feature selection.** The following features that characterize the roof shapes have been selected:

- Frequency distribution of roof surface aspects (bin width  $22.5^\circ$ , from  $0$  to  $360^\circ$ )
  - Frequency distribution of roof surface slope (bin width  $10^\circ$ , from  $0$  to  $90^\circ$ )
  - Number of surfaces for different roof shapes
  - Percentage of surface area within a certain slope range (bin width) to total surface area
  - Percentage of surface area within a certain aspect range (bin width) to total surface area
- (ii) Scale the entire data.** In this step, each feature is normalized by subtracting the mean of the feature and dividing it by the standard deviation. The label data also needs to be scaled.
- (iii) Label data.** The label data is used to train and test the classifier using SVM so as to apply the classifier for the rest of the data. No labelled data exists for Geneva roof shapes; thus, we need to label the data manually. 717 buildings (about 6% of total data) were manually labelled using a high quality aerial map from Swisstopo (<https://map.geo.admin.ch>) as well as Google Earth. We also label a similar quantity of buildings for each type of roofs (flat: 127, gabled: 127, hipped: 124, gambrel and mansard: 118, cross and corner hipped and gabled: 115, complex roofs: 106). SVM is used to classify the roof shapes for the rest of the buildings (11089).
- (iv) Testing and training in SVM.**
- The labelled data is divided into two unequal parts: 75% for training and cross validation and 25% for testing the classifier.
  - Radial basis function kernel is chosen because it offers the best accuracy.
  - Cross-validation is a model validation technique for assessing how the training dataset can be generalized to an independent dataset. K-fold cross-validation (the original sample is randomly partitioned into  $k$  equal-sized subsamples) is used in this study. K equal to 6 is set as the best for our data.
  - SVM classifier from the above step is used on the rest of the data to predict the roof shapes of the rest of the buildings in the city of Geneva.
  - Finally, classification accuracy metric is used to evaluate the performance of classifier. The metric is defined as:

$$accuracy = \frac{\psi}{\Omega} * 100\%$$

Where  $\psi$  is the number of correctly classified samples and  $\Omega$  is the total number of samples.

#### 5 RESULTS

The SVM classifier is able to identify the 6 types of roof shapes correctly in 66% of cases, that is, flat, gable, hip, gambrel & mansard, cross/corner gable & hip, and complex roofs. The results (Fig. 6) show that flat roofs, after complex roofs, have the second highest useful roof area for PV (normalized by the number of buildings in each category). The cross/corner gable & hip and gambrel and mansard are ranked as third and fourth, respectively. Hip and gable have the lowest useful area for PV production.



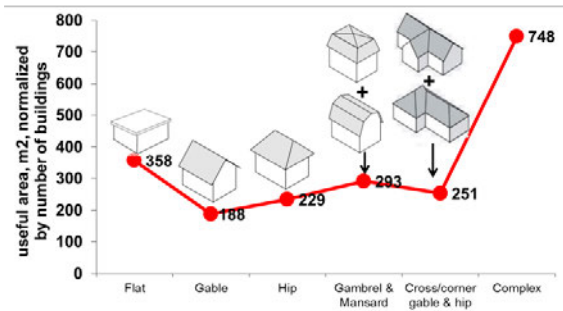

Fig. 6: Normalized useful roof areas for PV for different types of roof shapes.

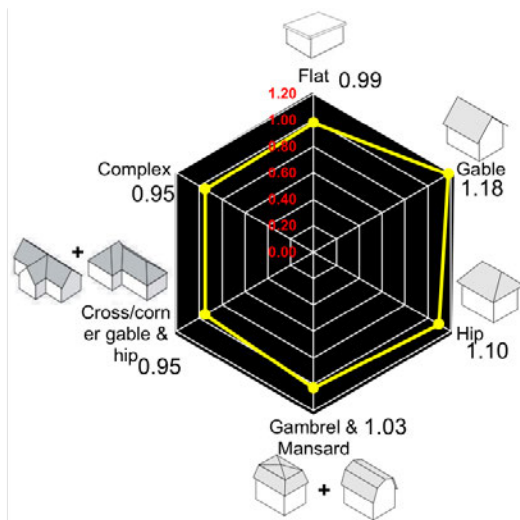

Fig. 7: Ratio of useful roof area to footprint area for different roof shapes.

The complex roofs belong to buildings with complex shape and large surface roof area such as museums, stations, and cathedrals and thus have much higher useful roof area than cross/corner gable & hip roofs.

The available roof area is estimated after removing the superstructures from the roofs, as well as 1m<sup>2</sup> from the margin of roof surfaces, and considering the 28m<sup>2</sup> threshold (only areas larger than 28m<sup>2</sup> are considered) for roofs due to the size of PV panel. Given the availability of the building footprint areas, it is also very useful to estimate the ratio of useful roof area for each type of roof shape to building footprint area (Fig. 7). For most of the roof shapes the ratio is close to one indicating that the footprint area can be used as a measure of the area available for PV. However, for hip and gable roofs the ratios are 1.10 and 1.18 (due to their steep slopes), respectively, making the footprints, particularly for the gable, less accurate estimates for PV areas.

For each roof shape, the yearly mean solar irradiation (kWh/m<sup>2</sup>) and the PV potential (kWh) are calculated (Fig. 8). The results show that flat roofs have the highest yearly mean solar irradiation, followed by the cross/corner hip & gable roofs and the hip roofs. Gable roofs receive the least solar irradiation. The PV potential for

roof shape in Geneva shows that flat roof and complex roof are the highest and gable is the lowest.

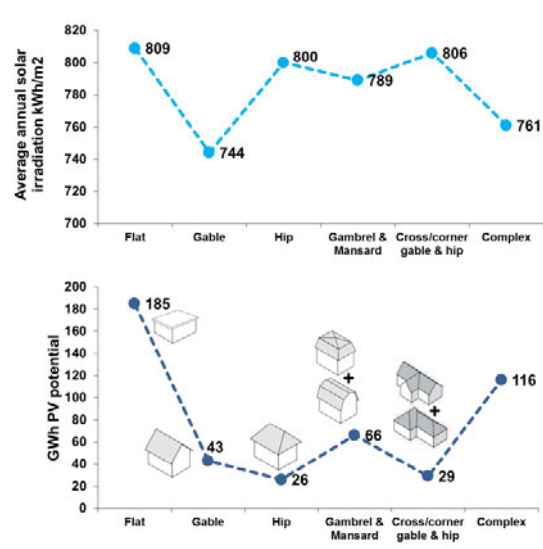

Fig. 8: Upper diagram, yearly mean solar irradiation (kWh/m<sup>2</sup>); lower diagram, PV potential (GWh) for different roof shapes.

## 6 SUMMARY

In this paper we use a data-driven approach to classify the roof shapes, the available roof areas for PV installation, and their potential for solar energy. The solar roof-shape classification provides basic information for designing new buildings, retrofitting interventions on the building roofs, as well as efficient solar integration on rooftops.

## 7 ACKNOWLEDGMENTS

This research has been financially supported by CTI (Commission for Technology and Innovation) within SCCER FEEB&D (CTI.2014.0119).

## 8 REFERENCES

1. L. Wiginton, H. Nguyen, and J. Pearce. Quantifying rooftop solar photovoltaic potential for regional renewable energy policy. *Computers, Environment and Urban Systems*, 34(4): 345–357, 2010.
2. S. Nowak, M. Gutschner, D. Ruoss, P. Togweiler, T. Schoen. Potential of building integrated photovoltaics. Report IEA-PVPS T7-4; 2002.
3. J. Goodling, R. Crook, A.S. Tomlin. 2015. Modelling of roof geometries from low-resolution LiDAR data for city-scale solar energy applications using a neighbouring buildings method. *Applied Energy* 148 (2015) 93–104.
4. Tarsha-Kurdi F, Landes T, Grussenmeyer P, Koehl M. Model-driven and data-driven approaches using LIDAR data: analysis and comparison, Munich 2007. p. 87–92.

5. M.C. Brito, N. Gomes, T. Santos, J.A. Tenedorio. Photovoltaic potential in a Lisbon suburb using LiDAR data. *Solar Energy* 86 (2012) 283–288.
6. C. Carneiro, E. Morello, and G. Desthieux. Assessment of solar irradiance on the urban fabric for the production of renewable energy using lidar data and image processing techniques. In *Advances in GIScience*, pages 83–112. Springer, 2009.
7. C. Carneiro, E. Morello, T. Voegtle, and F. Golay. Digital urban morphometrics: automatic extraction and assessment of morphological properties of buildings. *Transactions in GIS*, 14(4):497–531, 2010.
8. N. Lukac, S. Seme, D. Zlaus, G. Stumberger, B. Zalik. Buildings roofs photovoltaic potential assessment based on (Light Detection And Ranging) data. *Energy* 66 (2014) 598-609.
9. D. Assouline, N. Mohajeri<sup>1</sup>, J.-L. Scartezzini. A machine learning methodology for estimating rooftop photovoltaic solar energy potential in Switzerland. *Proceedings of International Conference on Future Buildings & Districts Sustainability from Nano to Urban Scale. Volume II*, 9 – 11 September 2015, EPFL Switzerland.
10. J. Gooding, R. Crook, A. S. Tomlin. Modelling of roof geometries from low-resolution LiDAR data for city-scale solar energy applications using a neighboring buildings method, *Applied Energy* 148 (2015) 93–104.
11. M. Kada, Scale-dependent simplification of 3D building models based on cell decomposition and primitive instancing. In: *Proceedings of the International Conference on Spatial Information Theory. COSIT'07. Melbourne, Australia 2007*. pp. 222–237.
12. C. Cortes, V. Vapnik, Support-vector networks. *Machine Learning*, 20(3):273–297,1995.
13. A. Hur-Ben, J. Watson. 2010. A user's guide to Support Vector Machines. *Methods Mol Biol.* 2010; 609:223-39. doi: 10.1007/978-1-60327-241-4\_13.
14. T. Hastie, R., Tibshirani, J. Friedman. 2013. *The Elements of Statistical Learning: Data Mining, Inference, and Prediction*. Springer Series in Statistics, USA.



## Expanding Boundaries: Systems Thinking for the Built Environment

### LCA AS KEY FACTOR FOR IMPLEMENTATION OF INERTIA IN A LOW CARBON PERFORMANCE DRIVEN DESIGN: THE CASE OF THE SMART LIVING BUILDING IN FRIBOURG, SWITZERLAND

A. Brambilla<sup>1\*</sup>, E. Hoxha<sup>1</sup>, T. Jusselme<sup>1</sup>, M. Andersen<sup>2</sup>, E. Rey<sup>3</sup>

<sup>1</sup> Ecole polytechnique fédérale de Lausanne (EPFL), Smart Living Building Research Group, Fribourg, Switzerland

<sup>2</sup> Ecole polytechnique fédérale de Lausanne (EPFL), Interdisciplinary Laboratory of Performance-Integrated Design (LIPID), School of Architecture, Civil and Environmental Engineering (ENAC), Lausanne, Switzerland

<sup>3</sup> Ecole polytechnique fédérale de Lausanne (EPFL), Laboratory of Architecture and Sustainable Technologies (LAST), School of Architecture, Civil and Environmental Engineering (ENAC), Lausanne, Switzerland

\*Corresponding author; e-mail: arianna.brambilla@epfl.ch

#### Abstract

The building sector is known as a major contributor to greenhouse gas (GHG) emissions and energy consumption. These impacts are commonly evaluated by life cycle assessment (LCA), which assess the potential impacts of a building from the construction to the end of life. LCA considers: the operating impacts (OI) occurring during the service life of buildings, and the embodied impacts (EI) occurring during the other lifecycle. Materials usually increase EI, but some of them, such as the ones used for thermal inertia (TI), concur to energy efficiency and can reduce OI. This makes it difficult to understand the role of such materials in low carbon building strategies. The aim of this study is to understand how to weigh the overall environmental benefits of TI. Four building models were used to assess LCA with either low, medium, high or very high levels of TI. These are reached using materials characterized by different embodied impacts, such as concrete and earth. The difference with the low inertia case, taken as the base case, is evaluated for each model regarding OI and EI. The comparison between OI and EI determines which scenario brings the lowest impacts on LCA. To evaluate how the results are influenced by climate change, the analysis is made with two different scenarios: one with the typical meteorological year (TMY, Meteoronorm) and the other with the weather conditions for 2050 (IPCC, International Panel on Climate Change).

The paper shows a methodology to evaluate the effects of a design strategy on the LCA, applied to the case of TI. It demonstrates that TI is not very relevant in the frame of this case study because the EI related to the added materials is higher than the induced operating savings. Furthermore, it has been demonstrated that in the future when the carbon content of the energy may be lower, TI can change its effects and negatively influence the lifecycle's environmental impacts.

#### Keywords:

building thermal inertia; LCA; environmental performances; sustainability; natural-based materials

#### 1 INTRODUCTION

The last decade witnessed an increasing awareness about environmental sustainability. Global warming and resource scarcity are amongst the biggest challenges to face

nowadays, especially in the construction sector which is responsible for 40% of the total energy consumption in the European Union [1]. The main cause of energy use in buildings is heating, though the production phase of buildings'

materials and components can significantly participate to the total energy consumption and environmental impacts [2]. Life cycle assessment (LCA) evaluates the impacts produced in the exploitation period of the building, called operative impacts (OI), and the ones involved in the materials production, transportation, manufacturing, buildings' construction and demolition phase (EI) [3]. The LCA has been applied to buildings materials and components in several applications [2, 4]. High efficient buildings have low energy consumption and, therefore, their associated OI are lower. In contrast, usually added materials, such as insulation, are used to improve the energy efficiency and, consequently, the EI increase. Even if the EI are becoming relevant on the buildings life cycle perspective, façades and materials choice usually aim to reduce the buildings impacts on the environment during the exploitation period. A first step towards reducing the effects of buildings on the environment should be the introduction of an integrated design approach which includes OI as well as EI. Despite this fact, there are only a few studies aiming to the optimization of buildings envelope considering both environmental and energy performances [5].

In this paper we propose a multi-criteria approach for the envelope's design, considering the effects on both embodied and operative phases of the building's whole lifecycle.

The effects of a given design solution must be balanced between EI and OI. Some strategies used to decrease one of these two contributions, could have negative effects on the other, reducing or nullifying the benefits on LCA. An example is the thermal inertia (TI), which could have positive effects on operating impacts [6], but could also have heavy impacts on the embodied part. In fact, it is usually achieved thanks to massive materials, such as concrete-based materials or bricks. However, it is proven that traditional concrete buildings have higher EI than ones with other construction technique [7]. Therefore, it is important to understand the potential of thermal inertia on LCA, considering both the savings regarding OI and the EI induced by the materials used to provide thermal mass.

## 2 METHODOLOGY

This paper aims to apply a methodology to evaluate the effects on LCA of TI employment as strategy to reduce heating consumption. Both operative and construction phase are taken into account: the reduction of OI due to a higher thermal inertial behaviour is compared to the increment of EI induced by the materials used to implement mass in the envelope. This methodology implies the comparison of different scenarios for a building, each one with a different influence on operative or embodied results. Two

groups of materials with different EI impacts are used: traditional (concrete and bricks) and natural (earthen materials). To vary the effects on OI, four levels of TI of the building are introduced according to the French thermal regulation [11]: *light, medium, heavy and very heavy*.

The analysis is made within the framework of the smart living building research programme. It aims to understand how it is possible to achieve in 2020, the 2050 goals according to the 2000 watt-society [8]. The smart living building will be designed and constructed in Fribourg, Switzerland, according to these principles and will be an innovative low-carbon building [9].

### 2.1 Case study

The smart living building will host:

- Services and experimental facilities on the ground floor
- Offices, on the 2<sup>nd</sup>, 3<sup>rd</sup> floors
- Housing, on the 4<sup>th</sup> and 5<sup>th</sup> floors

The case study is representative of a double office room, situated in the middle of the 3<sup>rd</sup> floor, orientated to south-east (Fig. 1). The dimensions and the internal loads are designed accordingly to the Swiss regulation [9]. Heat recovery is not used. The heating system adopted is an electrical heat pump, with a COP of 3.8 in all scenarios. Cooling loads and summer thermal comfort are considered not to be an issue. Therefore, the attention is focused only on the heating part and the benefits of TI on energy consumption.

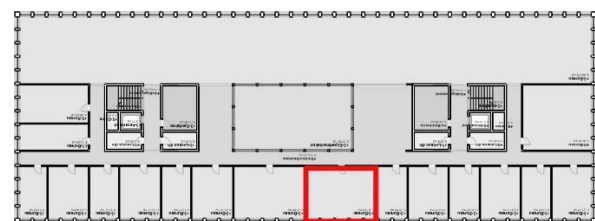

Fig. 1: Smart living building, office floor. In red the room considered: 6x6m.

### 2.2 Thermal inertia

TI in buildings help to lower temperature peaks and store heat from solar radiation and internal loads, decreasing energy requirements [6, 10]. It is strictly dependent on the thermal mass of the components, which is the function of materials properties, such as heat capacity, density and conductivity. TI effectiveness derives from the interactions among different parameters, both related to the mass of the building's components and building's design features, as climatic conditions, windows area, insulation, ventilation, internal loads, occupancy and active systems [5]. Due to these correlations, several ways to consider and estimate inertial behaviour in constructions are recognized and used in different studies and standardisations [10]. In this paper, the French thermal regulation is used as a reference [11] because it allows to consider

transitorily phenomena. In fact, the heat capacity of materials is weighted on their mass and surface of application. In this analysis four different levels are considered: *light*, *average*, *heavy* and *very heavy*. Assuming that in each scenario the TI level is the only variable, heating demand is expected to decrease with higher TI levels and the consequent effect is a reduction of the OI. To affect also the EI, these levels are reached through two different group of materials: traditional (cement matrix or bricks) and natural (earth). The composition of walls, ceilings and floors changes in each scenario, in order to achieve the TI levels desired with reliable components. It is necessary to change all of them to have a variation on the final inertial level, since the mass is weighted on the overall surface of exposure. Each scenario is composed by different components, which are design varying only the layers that really affect the inertial behaviour. The principal layers of the components are described in the following table.

name	LAYERS	THICKNESS [cm]	DENSITY [kg/m <sup>3</sup> ]	CONDUCTIVITY [W/m <sup>2</sup> K]	CAPACITY [kJ/kg <sup>o</sup> K]
<b>Horizontal enclosure (floor and ceiling)</b>					
<b>fixed part</b>	cork panel	0.5	175	0.046	1.5
	reinforced concrete	20	2300	2.3	1
	cellulose insulation	10	80	0.048	1.6
<b>tr-h1 traditional light</b>	ceramic tiles	1	1900	1	1
	light cement screed	5	1000	0.3	1
	<b>fixed part</b> plasterboard	1.25	850	0.21	0.79
<b>tr-h2 traditional medium</b>	ceramic tiles	1	1900	1	1
	light cement screed	5	1000	0.3	1
	<b>fixed part</b> mineral plaster	1.5	1200	0.7	2.8
<b>tr-h3 traditional heavy</b>	ceramic tiles	1	1900	1	1
	light cement screed	6	1000	0.3	1
	<b>fixed part</b> mineral plaster	2.5	1200	0.7	2.8
<b>nat-h1 natural light</b>	rammed earth	5	1900	1	1
	<b>fixed part</b> earth plaster low den	2.5	1400	0.59	1
<b>nat-h2 natural medium</b>	rammed earth	5	1900	1	1
	<b>fixed part</b> earth plaster high den	2.5	1800	0.91	1
<b>nat-h3 natural heavy</b>	rammed earth	6	1900	1	1
	<b>fixed part</b> earth plaster high den	3	1800	0.91	1

<b>EXTERNAL WALLS fixed part</b>					
<b>fixed part</b>	cellulose insulation	30	80	0.048	1.6
	wooden panel, type OSB	2.5	1200	0.7	2.8
	cement plaster	0.5	1500	1	1
<b>tr-e1 traditional light</b>	cement plaster	2	1500	1	1
	wooden panel, type OSB	1	1200	0.7	2.8
	<b>fixed part</b>				
<b>tr-e2 traditional medium</b>	mineral plaster	2	1200	0.7	2.8
	wooden panel, type OSB	1	1200	0.7	2.8
	<b>fixed part</b>				
<b>tr-e3 traditional heavy</b>	mineral plaster	2.5	1200	0.7	2.8
	masonry bricks	6	1100	0.44	0.9
	<b>fixed part</b>				
<b>nat-e1 natural light</b>	earth panel low den	2.5	650	0.2	1.3
	<b>fixed part</b>				
<b>nat-e2 natural medium</b>	earth panel high den	2.5	1700	0.8	1
	<b>fixed part</b>				
<b>nat-e3 natural heavy</b>	earth plaster high den	2.5	1700	0.8	1
	compressed earth block	6	1900	1.1	1
	<b>fixed part</b>				
<b>INTERNAL WALLS fixed part</b>					
<b>fixed part</b>	cellulose insulation	30	80	0.048	1.6
	wooden panel, type OSB	0.5	1200	0.7	2.8
	mineral plaster	0.5	1200	0.7	2.8
<b>tr-i1 traditional light</b>	mineral plaster	0.5	1200	0.7	2.8
	plasterboard	2.5	850	0.21	0.79
<b>tr-i2 traditional medium</b>	cement plaster	1	1500	1	1
	plasterboard	2.5	850	0.21	0.79
<b>tr-i3 traditional heavy</b>	mineral plaster	1	1200	0.7	2.8
	cement board	1	2400	1.48	1.1
<b>tr-i4 traditional heavy +</b>	mineral plaster	2.5	1200	0.7	2.8
	masonry bricks	10	1100	0.44	0.9
<b>nat-i1 natural light</b>	earth panel low den	2.5	650	0.2	1.3
	<b>fixed part</b>				
<b>nat-i2 natural medium</b>	earth plaster high den	2.5	1800	0.91	1
	wooden panel, type OSB	1	1200	0.7	2.8
	<b>fixed part</b>				
<b>nat-i3 natural heavy</b>	earth plaster high den	3.5	1800	0.91	1
	wooden panel, type OSB	1	1200	0.7	2.8
	<b>fixed part</b>				
<b>nat-i4 natural heavy +</b>	earth plaster high den	2.5	1800	0.91	1
	compressed earth block	10	1900	1.1	1
<b>fixed part</b>					

Tab. 1: Description of the main layers of the components. Layers described from the inner side to the outside.

It is assumed that thermal mass is not affecting any other aspect of the construction except for TI. The structures, for example, are kept fixed even if heavier components are used in order to achieve a higher level of TI.

### 2.3 Embodied evaluation

Life cycle environmental impacts are evaluated with the KBOB database [12]. The results are expressed for the three main indicators of LCA:

global warming potential (GWP), cumulative energy demand (CED) and cumulative non-renewable energy demand (CEDnr). The analysis of 2050 scenarios are made only on climate change (GWP). According to the study [13], three different carbon content for the electrical grid are considered (WWB, NEP and POM). The evaluations include all the life cycle phases, including the saving potential introduced by TI.

#### 2.4 Operative simulations

Buildings have usually a long life span [14]. On the other hand, global warming and climate change are changing the entire environment and ecosystem. Therefore, buildings built today will face a different external context tomorrow. For this reason, their thermal behaviour will be different in the future. Thence, TI may change its potential as strategy to reduce heating consumption, according to the time of evaluation. Aiming to a life cycle performant building, the potential of TI must be estimated both for the current climate and the future context to assure that the efficiency will not decrease either become a criticism, increasing the overall environmental impacts. Therefore, the heating consumption during the operative phase is evaluated both for actual and future climate.

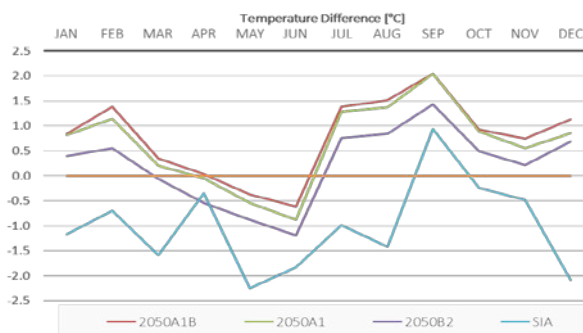

Fig. 2: Temperature variation: 2015 climate file (orange lines) and scenarios of IPCC for 2050.

All the weather files are generated by the software METEONORM [15]. The future weather files are created from the different possible scenarios studied by the Intergovernmental Panel on Climate Change (IPCC). Temperature could rise in 30 years up to 2 degrees more. Thus, it is clear that this variation can influence the role of inertia in comfort and energy saving strategies. Dynamic operative impacts are simulated using the software TRNSYS [16].

### 3 SCENARIOS

The scenarios are identified combining all the parameters described: level of inertia (light, average, heavy and very heavy), type of materials (traditional and earthen), and future scenarios with climatic file (2015, 2050 A2, 2050 B1 and 2050 A1B) and 2050 carbon content projections (WWB, NEP and POM). The table

shows the basic scenarios, obtained from the first two parameters.

SCENARIO	external walls	floor	internal walls
1: LIGHT TRAD.	tr-e1	tr-h1	tr-i1
2: MEDIUM TRAD.	tr-e1	tr-h2	tr-i2
3: HEAVY TRAD.	tr-e2	tr-h3	tr-i3
4: HEAVY+ TRAD.	tr-e3	tr-h3	tr-i4
5: LIGHT NAT.	nat-e1	nat-h1	nat-i1
6: MEDIUM NAT.	nat-e1	nat-h2	nat-i2
7: HEAVY NAT.	nat-e2	nat-h3	nat-i3
8: HEAVY+ NAT.	nat-e3	nat-h3	nat-i4

Tab. 2: Table of the scenarios with the different components to achieve the TI level both for natural and traditional materials. The components used are described in Tab. 1.

### 4 CONCLUSIONS

The results are analysed in comparison with the light level of TI for each group of materials: for earthen scenarios the reference is case 5, for traditional scenarios, it is case 1. The increment percentage of EI of each scenario compared to the base-case is analysed regarding to the OI related savings, in order to evaluate if a scenario brings benefits on the LCA. The following graphs report the results of the 2015 scenarios on the three main indicators, and 2050 scenarios on GWP. The line represents the cases in which the OI savings are equal to the EI increments. If a point is above the line, it means that operating benefits are bigger than embodied increment for the considered scenario, inducing a total decrement of environmental impacts comparing to the light TI level. At the opposite, if a point is below the line, OI reduction doesn't balance the higher EI of the related scenario. In this case, on LCA the environmental impacts are higher than the base case. From Fig. 3 it is possible to observe that natural materials have always positive effects on LCA, while traditional materials influence negatively GWP for all the thermal inertia scenarios. The very heavy scenarios are the most influent on LCA for both materials groups, but the effects are interesting only on the energy part (CED and CEDnr). For these indicators the operative savings can reach 6% on the total value, in the case of traditional materials, but only 3% for natural ones. It is clear that the very heavy TI level is the most promising. On the other hand, GWP is the limiting indicator, nullifying the benefits on CED and CEDnr for traditional materials.

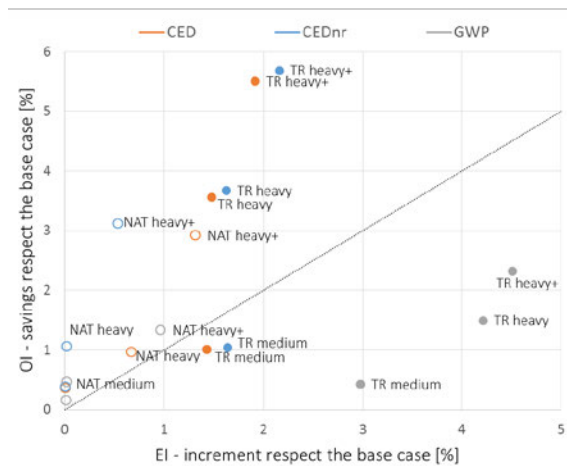

Fig. 3: Results of the analysis for 2015 and the three main LCA indicators (NAT: natural materials, TR: traditional materials).

Therefore, we can conclude that thermal inertia is not an interesting strategy to reduce environmental impacts when traditional materials are used. While, if natural materials are implemented, TI have always benefits on LCA, but these improvements are not relevant in the framework of this study.

Fig. 4 and Fig. 5 show the results for 2050. These are expressed only for GWP and very heavy TI levels, since that climate change is the most critical indicator and this TI level is the most promising. Fig. 4 is referred to traditional materials and Fig. 5 to natural ones. Based on Fig. 4 and Fig. 5, it is interesting to note that the electrical carbon content scenarios are more influent than the climate scenarios.

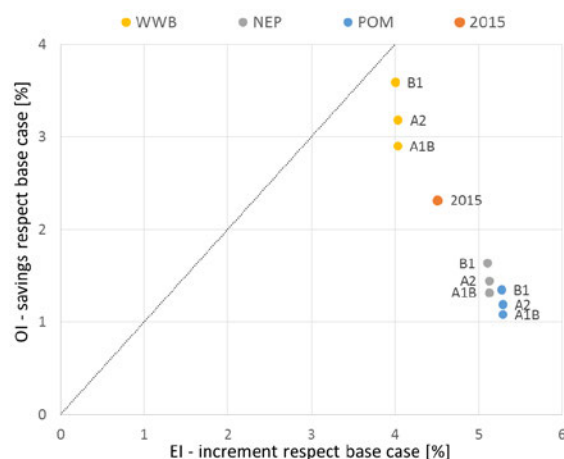

Fig. 4: GWP indicators results for the very heavy TI scenario, with traditional materials. Three scenarios for carbon content of the electrical grid (WWB, NEP and POM) and three scenarios for 2050 climate (A2, B1 and A1B) are considered.

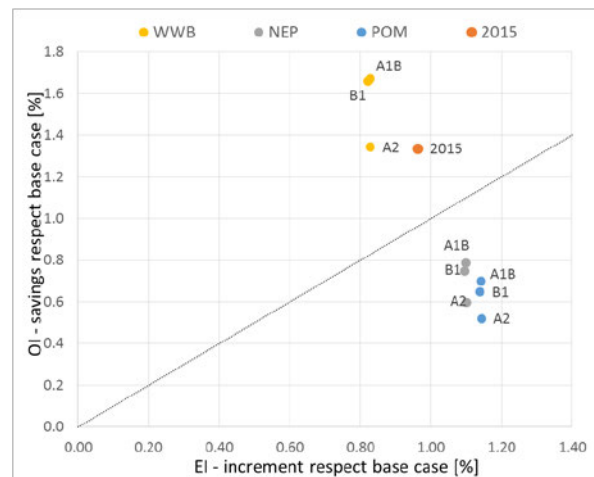

Fig. 5: GWP indicators results for the very heavy TI scenario, with natural materials. Three scenarios for carbon content of the electrical grid (WWB, NEP and POM) and three scenarios for 2050 climate (A2, B1 and A1B) are considered.

For traditional materials the higher level of TI corresponds always to an overall increase of environmental impacts. Results for natural materials change completely comparing to the 2015 scenario. According to the carbon content scenario that is considered, in fact, the overall impacts can be reduced or increased, in comparison to the light case. Among all the scenarios analysed for 2015, the very heavy TI level achieved with natural materials was the most promising. Considering lower carbon content of the grid (NEP and POM), instead, TI loses its potential to decrease building's environmental impacts, while the increment of embodied impacts remains the same. From Fig. 4 and Fig.5 it is clear that to lower CO<sub>2</sub> content of the electrical energy correspond lower influence of TI on operating savings. Therefore, it is possible to conclude that TI is not an interesting strategy to reduce environmental impacts in the future. On the contrary, if the energy source is cleaner, then TI can become a criticism for the overall building's impacts.

## 5 DISCUSSION

This paper analysed the influence of TI on buildings life cycle performances. It underlines the importance of an integrated approach which could consider both OI and EI. The results show that TI is an interesting passive strategy to save energy for heating and to reduce environmental impacts over the whole life cycle only under certain conditions. The relevance of this solution is linked to the materials that is used to implement inertial levels in the construction and to the carbon content of the energy source.

It is important to contextualize the results to the reference case, situated in Switzerland. All the conclusions must be considered in the framework

of this study. Moreover, all the results obtained are strictly dependant to the assumptions made during the analysis, and the validity is confined inside the defined boundaries.

Although design guidelines in Switzerland suggest to focus on heating, also the assumption of no cooling loads can be limiting in understanding the real effects of TI on buildings. Summer comfort is an issue that should be investigated. TI can vary its potential in buildings application if this issue is taken into account. TI effects are not purely passive but the emission process of the stored heat depends also on building's features and the active systems of indoor environment control. For example, indoor temperature set point has a great influence on determining the heat exchange within the internal elements heated and the surrounding.

All these assumptions open the question for deeper studies. Future works will try to understand the role of inertia in relation to buildings features, such as windows to wall ratio, active systems, internal gains and thermal behaviour. It will be important to understand which is the correlation between all these parameters and the inertial behaviour of the construction with a LCA approach.

## 6 ACKNOWLEDGMENT

We are grateful to the research unit "Architecture, Environnement et Cultures Constructives" from the Architectural School in Grenoble for providing the data necessary to design reliable building's components with earthen materials.

## 7 REFERENCES

- 1 Directive 2010/31/EU of the European Parliament and of the Council of 19 May 2010 on the energy performance of building (recast). Off J Eur Commun 2010
- 2 Bribian IZ., Uson AA. and S. Scarpellini, Life cycle assessment in buildings: state of the art and simplified LCA methodology as a complement for building certification. *Build Environment*, 2009. 44: p. 2510-20.
- 3 ISO 14040. Environmental management - Life cycle assessment - Principles and framework. 2006. International standard.
- 4 Erlandsson M. and M. Borg, Generic LCA and methodology applicable for buildings, constructions and operation services and today practice and development needs. *Build Environment*, 2003. 38(7): p. 919-38.
- 5 Stazi F., Mastrucci A. and P. Munafò, Life cycle assessment approach for the optimization of sustainable building envelopes: An application on solar wall systems. *Building and Environment*, 2012. 58: p. 278-288.
- 6 Aste N., Angelotti A., and M. Buzzetti, The influence of the external walls thermal inertia on the energy performance of well insulated buildings. *Energy and buildings*, 2009. 4: p. 1181-1187.
- 7 Doodoo A., Hustavsson L. and R. Sathre, Effect of thermal mass on life cycle primary energy balances of a concrete- and a wood-frame building. *Applied Energy*, 2012. 92: p. 462-472.
- 8 Jochem E., et al., Step towards a sustainable development: A white book for R&D of energy-efficient technologies. 2004. Novatlantis.
- 9 Jusselme T., et al., Building 2050: scientific concept and transition to the experimental phase. 2015. EPFL-Fribourg, Switzerland.
- 10 SIA 2024 Cahier technique, Conditions d'utilisation standard pour l'énergie et les installations du bâtiment. 2007.12. Karlsson J., Possibilities of using thermal mass in buildings to save energy, cut power consumption peaks and increase the thermal comfort. Lund Institute of Technology, Lund University. 2012, Lund, Sweden
- 11 RT 2012- Regles TH-I (mars 2012): caractérisation de l'inertie thermique des bâtiments. 2012.
- 12 KBOB, Ökobilanzdaten im Baubereich. Koordination der Bau und Liegenschaftsorgane der öffentlichen Bauherren. 2009, Bern.
- 13 Stadt Zurich, Life Cycle Assessment of Electricity Mixes according to the Energy Strategy 2050. 2013.
- 14 Kornmann M. and Queisser A., Service life of building stock in Switzerland. *Mauerwerk, European Journal of masonry*, 2012. 16(4): p. 210-215
- 15 Meteonorm V 6.1, [www.meteonorm.com](http://www.meteonorm.com). 2008.
- 16 Klein, S.A. et al., TRNSYS 17: A Transient System Simulation Program, Solar Energy Laboratory, University of Wisconsin. 2012 Madison, USA, <http://sel.me.wisc.edu/trnsys>.





## Expanding Boundaries: Systems Thinking for the Built Environment

### TUNING ENERGY PERFORMANCE SIMULATION ON BEHAVIOURAL VARIABILITY WITH INVERSE MODELLING: THE CASE OF SMART CAMPUS BUILDING

L.C. Tagliabue<sup>1\*</sup>, M. Manfren<sup>2</sup>, A.L.C. Ciribini<sup>1</sup>, E. De Angelis<sup>3</sup>

<sup>1</sup> University of Brescia, Department DICATAM, Via Branze 43, 25123 Brescia, Italy

<sup>2</sup> University of Bologna, Department of Industrial Engineering (DIN), Viale del  
Risorgimento 2, 40136, Bologna, Italy

<sup>3</sup> Politecnico di Milano, Architecture, Built environment and Construction Engineering Department, Via  
Ponzio 31, 20133 Milano, Italy

\*Lavinia Chiara Tagliabue; e-mail: chiara.tagliabue@polimi.it

#### Abstract

In order to establish a reliable model of occupants' interactions with indoor environment, a method accounting for stochastic factors is used. The result is no more a "single value" for the system performance, but a probability to fulfil a certain performance over time. In this way, occupant behaviour is not deterministic (e.g. the opening of windows when indoor temperature exceeds a threshold value) but coupled with a probability to perform an action.

The proposed approach is built upon continuous measurements of both indoor environmental parameters and external climate conditions along with the behaviour of the building occupants (such as window opening, thermostat radiator valve, set point temperatures, occupancy sensors, etc.), performed in a sufficient number of areas and rooms representing different interaction zones in the case study. The monitoring period can range from medium (i.e. one week better if repeated in different seasons) to long-term periods (i.e. a year). The simple measurement of time series of physical quantities (such as relative humidity, temperature, pollutant concentrations, luminance, etc.) generates huge amounts of data that can be hard to "translate" directly into a behavioural model. In order to overcome these barriers, different suitable models can be defined using statistical techniques such as logistic regression and Markov chains.

The various occupancy profiles are then inserted into the chosen dynamic simulation software. A monitoring and control scheme that detects users' occupancy, lighting levels, temperature, humidity, CO<sub>2</sub> and manages HVAC system settings has been designed and installed. This system has been design to enable a faster "as-built" energy model calibration, using data from commissioning and early occupancy phases.

Therefore, the actual measurement in the building will give the possibility of extracting useful information to calibrate the building energy model with a probabilistic behavioural model fitted to real metered data through inverse modelling.

#### Keywords:

Probabilistic approach, behavioural variability, energy performance, inverse modelling

#### 1 INTRODUCTION

The relevant gap between simulated and measured energy performance can be fundamentally caused by design phase, construction phase, commissioning and operational phase errors [1]. In the design phase, on the modelling side, errors are mostly connected

to biased assumptions (generally optimistic) on building components and subsystems. Further, the large variability of technological solutions, end-uses and behavioural patterns [2] within the built environment makes it very difficult to define a unified and yet flexible modelling approach. With respect to behavioural patterns in particular, the

relation among parameters related to occupancy, such as air change rates and internal heat gains (i.e. due to people, lighting and equipment), can be determined by means of statistical modelling approaches when sufficient data are available [3-5]. It is thus necessary to unveil, even in the design phase, the potential impact of the variability of occupants' behaviour on energy performance [6]. This can be seen as an "occupant proofing" process from building performance simulation standpoint, able to clarify the role of occupants in gaining a high level of energy performance. In fact, modelling assumptions can become an issue (in terms of robustness and risk) when predicting future performance, especially in techno-economic feasibility evaluations such as cost-optimal [7] and life cycle cost (LCC) analyses, which are crucial for the definition of energy efficiency investments, or energy performance contracting (EPC). These issues can be uncertain thermal characteristics of the building fabric, of the technical systems, variable operational patterns, uncertain level of internal environmental quality (e.g. indoor air quality), etc. In a general sustainability perspective, the environmental and economic impacts related to energy demand, although described with different performance indicators, are strictly correlated with the social (and behavioural) dimension of the problem (environment, economy and society are the three pillars of sustainability). This dimension is represented by the type of activities within the built environment and by the internal environmental quality (e.g. air quality, thermal comfort, visual comfort, etc.), perceived by the occupants [8], that ultimately determines the "success" or "failure" of a built environment itself with respect to its scope.

## 2 METHODOLOGY

The methodological approach is applied to the initial energy modelling phase (design phase for the building refurbishment) and is conceived to be extended and validated during building operation, by means of a performance monitoring system aimed for detailed data acquisition; data that will be analysed to address relevant technical issues, generally encountered in model calibration [9-13]. The research work aims, in general, at integrating direct and inverse modelling techniques [14-16] (i.e. establishing a continuity between modelling practices used in the design phase and model calibration techniques in the building operation phase). Actually, the availability of validated and calibrated building energy models is fundamental to explore accurately efficiency measures and optimized operational strategies during the whole building lifecycle, considering also the economic counterparts in terms of investment and operating costs (either for new construction or refurbishment), which can determine whether a project is feasible or not. The probabilistic

modelling approach starts from basic building survey and energy audit data, together with assumptions about building occupancy similar to other studies [17-19].

## 3 THE SMART CAMPUS BUILDING

The ongoing multidisciplinary research on the Smart Campus Building of the University of Brescia, Italy [20-21], involves several topics ranging from BIM (Building Information Modelling) to BEM (Building Energy Modelling), performance optimization, performance monitoring/tracking and optimal control. In this paper, the focus is the probabilistic modelling of occupancy within the building, considering the effects in terms of energy performance and the problem of model calibration and anomaly detection in the early monitoring phase, after the refurbishment. The building is used as a field testing of the multi-disciplinary research initiative "Smart Campus School Project" carried out by the University of Brescia to show the potential for building refurbishment with smart technologies, considering technological and behavioural learning problems. The building has three floors, underground, ground and first floor, with lecture halls and computer labs, and a glazed atrium in which the students can conduct their individual studies (Fig. 1).



Fig. 1: Interior views of the building.

The considered building zones are described synthetically in table 1.

Floor	Name	Typology
Underground	MLAB1	Computer lab
	MLAB2	Computer lab
Ground	MTA	Classroom
	MTB	Classroom
	Atrium	Common area
First	M1	Aula magna

Table 1: Use of the internal spaces.

A south facing external view of the building and of the BEM model are reported in Fig. 2 and Fig. 3.



Fig. 2: Brescia Smart Campus Building, Italy.

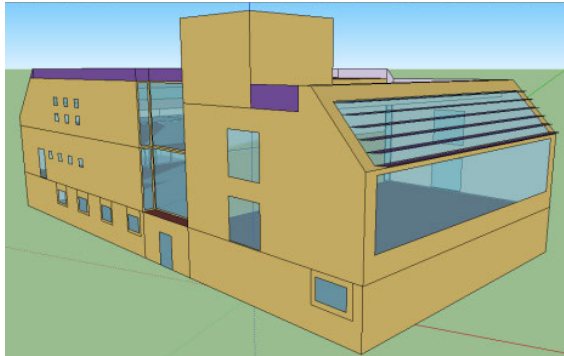

Fig. 3: Building energy model in EnergyPlus.

After zoning, we determined the operational state and the occupancy of the zones on the basis of a sample weekly operation schedule. The use of the lecture halls is intensive but the actual attendance to the lectures hasn't been measured continuously up to now, but it will be monitored by person counters and data collected in the next weeks.

## 4 RESEARCH METHODOLOGY

### 4.1 Building spaces and users

In the starting phase of the research activity, a building survey and an energy audit have been conducted, to identify the maximum allowable people occupancy for the different zones. Data is reported in table 2.

Floor	Name	Surface [m <sup>2</sup> ]	Users n <sub>o,max</sub>
Underground	MLAB1	151.8	56
	MLAB2	207.9	82
Ground	MTA	178.3	168
	MTB	177.5	168
	Atrium	180.8	56
First	M1	337.5	262

Table 2: Size and users of the internal spaces.

### 4.2 Probability distribution

The maximum people number  $n_{o,max}$  has been considered for the generation of occupancy scenarios, using a triangular probability distribution (min = 0,3  $n_{o,max}$ , mode = 0.6  $n_{o,max}$ , max = 1.0  $n_{o,max}$ ).

In synthesis, while the standard simulation assumes a fixed people density, the probabilistic one simulates the profiles generated by means of a triangular probability distribution and sets the user dependent parameters accordingly. Given the probabilistic nature of the outcomes, the results will be represented by (similarly to a boxplot graphical method):

- minimum
- first quartile (25% of simulation data)
- median (50% of data)
- third quartile (75% of simulation data)
- maximum

The results are compared to a standard calculation (with standard data for the educational use of the building).

### 4.3 Monitoring and inverse modelling

A continuous monitoring phase (started recently) and the following analysis will be carried out in the next months and years. However, criteria to enable a methodological continuity between direct and inverse modelling are provided in this research stage (Fig. 4). The sensor data will enable the calibration of the building energy model, including occupant's behaviour. In the case study considered, the people counters will be crucial to verify the real occupants' number during the different periods of the year and CO<sub>2</sub> concentration sensors will be used for the control of the mechanical ventilation system (e.g. modulation of airflow handled by AHUs by means of a stepped or continuous control logic). Further, the CO<sub>2</sub> sensors will provide detailed information about actual indoor air quality, enabling the inverse estimation of the number of people within a certain zone. Another inverse modelling strategy will be based on multiple linear regression model, used to estimate influential parameters [22,23] and to calibrate progressively the building energy model by estimating inversely macro-parameters. The starting point can be considered the use of weather-adjusting visualization [24].

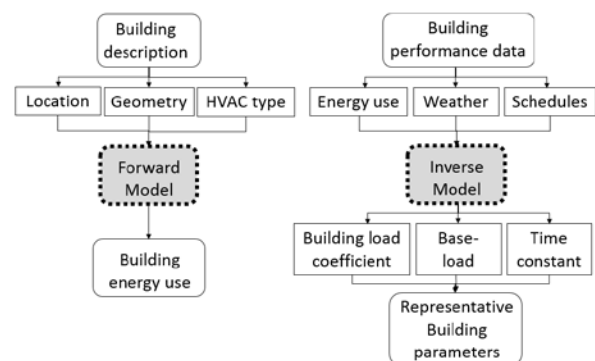

Fig. 4: Basic approach of a typical forward energy analysis model (left) and of a typical inverse energy analysis model (right).

The list of installed sensors is reported in table 4.

Control	Function	Sensor typology	Type	N.
Lighting	Presence	Presence	L <sub>1</sub>	24
	Daylighting control	Luminance	L <sub>2</sub>	4
Ventilation	Air control	Inlet air temperature	V <sub>1</sub>	15
		Outdoor air temperature	V <sub>2</sub>	8
		Relative humidity	V <sub>3</sub>	9
Heating	Emission control	Presence, CO <sub>2</sub> , ventilation and conditioning damper	H <sub>1</sub>	18
Cooling	Emission control	Presence, CO <sub>2</sub> , ventilation and conditioning damper	C <sub>1</sub>	18

Table 4: Installed sensors: Typology.

#### 4.4 Modelling approach

The used modelling approach considers the strict interaction between occupants' behaviour and building performance, focusing primarily on the following fundamental aspects:

- thermal comfort (i.e. set-point for heating and cooling)
- internal air quality (e.g. CO<sub>2</sub> concentration)
- internal heat gains (i.e. occupancy, equipment and lighting)
- electricity consumption

This does not imply the use of complex models, but rather the use of simple but coherent assumptions in a probabilistic framework. The number of occupants, appliances and lighting power are generated according to a probability distribution. The main variables are:

- presence/absence of people in a building zone (0-1, binary variable, e.g. a lesson in a classroom)
- variable percentage of occupants within the building zone (from minimum to maximum value assumed, following a probabilistic distribution)
- assumption for the calculation of air change rate (CO<sub>2</sub> concentration due to occupancy)
- internal gains dependent on occupancy (number of people, appliances, lighting);
- internal gains independent by occupancy (appliances, lighting)
- electricity consumption dependent/independent on occupancy (appliances and lighting)

The proposed probabilistic simulation approach aims to extend the current design procedures for energy simulation, based on deterministic criteria, to more general stochastic ones [25,26]. In the research, a fixed internal distribution of functions (fixed end-use for different zones) is assumed (given the characteristics of the case study).

## 5 RESULTS

The variability of the daily thermal energy demand for heating and cooling is reported in Fig. 5 and Fig. 6. The results show the potentially large variability in the daily energy need for heating and cooling in the different operating scenarios and the difference from the standard calculation that underestimates the cooling demand and overrates the heating demand (due to internal gains and ventilation rates). The variability considered in internal operation patterns is particularly large and is aimed at exploring also pessimistic operation scenarios. Starting from this data, it will be possible in the operation phase to compare graphically simulated data and measured data and to characterize the average thermal gains due to people occupancy (knowing also the amount of electricity demand for different uses within the building) using multivariate regression. This strategy is simple compared to a detailed definition of occupancy probability distribution determined directly from data but can be very effective for performance control. In the envelopment of the simulation conditions considered (Fig. 7), the hourly consumption patterns, differently from the daily patterns, can show critical peak conditions, the potential for free-cooling and occupancy variability (graphical methods). The deterministic, code compliance based, way to account for occupancy patterns in energy modelling is not realistic, because it doesn't give enough information with respect to the variability of the performance determined by occupants.

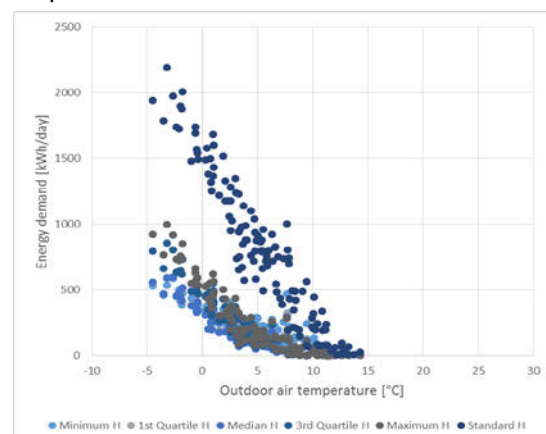

Fig. 5: Heating energy demand vs outdoor air temperature.

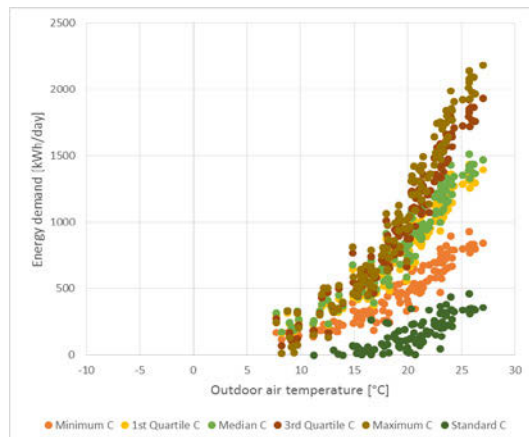

Fig. 6: Cooling energy demand vs outdoor air temperature.

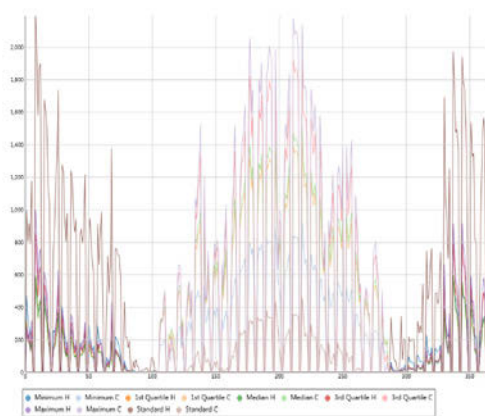

Fig. 7: Energy demand development for the tested occupancy profiles.

## 6 DISCUSSION

Occupancy patterns' variability contributes (among other factors) to the wide performance gap between predicted and real conditions. A parametric or probabilistic simulation strategy could partially respond to the issue, coherently with the premises to adopt a more representative modelling strategy, suitable for design phase analysis. Subsequently, inverse modelling techniques should be used to calibrate the building model during building operation in order to progressively give more consistency to model output data, i.e. by reducing their gap with respect to measured data. For this reasons continuous monitoring is necessary to ensure adequate performance, and to validate the approach applied in the design phase [27], nonetheless the possibility to evaluate the impact of occupants from the very beginning constitutes an important improvement over current practices.

## 7 CONCLUSIONS

At the core of the research approach there is the effort to provide a continuity in the workflow among design phase, simulation models and procedures

to tune energy models with data collected in the operation phase, i.e. calibration. More in general, the scope of the multidisciplinary research on the Smart Campus Building is to bridge, on the one hand, the gaps traditionally separating the design and energy simulation domains and, on the other hand, the gaps between simulated and measured building performance, in real time operation, for optimal control and energy management.

## 8 ACKNOWLEDGMENTS

The authors would like to acknowledge the team leader of Smart Campus School Project in University of Brescia Eng. Alessandra Flammini and Eng. Stefano Rinaldi.

## 9 REFERENCES

1. De Wilde P., The gap between predicted and measured energy performance of buildings: A framework for investigation, *Automation in Construction*, 41 (2014) 40-49.
2. Li C., Hong T., Yan D., An insight into actual energy use and its drivers in high-performance buildings, *Applied Energy*, 131 (2014) 394-410.
3. Zhao J., Lasternas B., Lam K.P., Yun R., Loftness V., Occupant behavior and schedule modeling for building energy simulation through office appliance power consumption data mining, *Energy and Buildings*, 82 (2014) 341-355.
4. D'Oca S., Hong T., Occupancy schedules learning process through a data mining framework, *Energy and Buildings*, 88 (2015) 395-408.
5. D'Oca S., Hong T., A data-mining approach to discover patterns of window opening and closing behavior in offices, *Building and Environment*, 82 (2014) 726-739.
6. Feng X., Yan D., Hong T., Simulation of occupancy in buildings, *Energy and Buildings*, 87 (2015) 348-359.
7. Corgnati S.P., Fabrizio E., Filippi M., Monetti V., Reference buildings for cost optimal analysis: Method of definition and application, *Applied Energy*, 102 (2013) 983-993.
8. Menezes A.C., Cripps A., Bouchlaghem D., Buswell R., Predicted vs. actual energy performance of non-domestic buildings: Using post-occupancy evaluation data to reduce the performance gap, *Applied Energy*, 97 (2012) 355-364.
9. Coakley D., Raftery P., Keane M., A review of methods to match building energy simulation models to measured data, *Renewable and Sustainable Energy Reviews*, 37 (2014) 123-141.

10. Fabrizio E., Monetti V., Methodologies and Advancements in the Calibration of Building Energy Models, *Energies*, 8 (4) (2015) 2548-2574.
11. Manfren M., Aste N., Moshksar R., Calibration and uncertainty analysis for computer models – A meta-model based approach for integrated building energy simulation, *Applied Energy*, 103 (2013) 627-641.
12. Rodríguez G.C., Andrés A.C., Muñoz F.D., López J.M.C., Zhang Y., Uncertainties and sensitivity analysis in building energy simulation using macroparameters, *Energy and Buildings*, 67 (2013) 79-87.
13. Yang Z., Becerik-Gerber B., A model calibration framework for simultaneous multi-level building energy simulation, *Applied Energy*, 149 (2015) 415-431.
14. Krarti M., Weatherization and energy efficiency improvement for existing homes: an engineering approach, CRC Press (2012).
15. Reddy T.A., Applied data analysis and modeling for energy engineers and scientists, Springer Science & Business Media (2011).
16. Tronchin L., Manfren M., Tagliabue L.C., Multi-scale analysis and optimization of building energy performance—Lessons learned from case studies, *Procedia Engineering* 118 (2015) 563 – 572.
17. Macdonald I., Strachan P., Practical application of uncertainty analysis, *Energy and Buildings*, 33 (3) (2001) 219-227.
18. Macdonald I.A., Quantifying the effects of uncertainty in building simulation, University of Strathclyde (2002).
19. Hopfe C.J., Hensen J.L., Uncertainty analysis in building performance simulation for design support, *Energy and Buildings*, 43 (10) (2011) 2798-2805.
20. De Angelis E., Ciribini A., Tagliabue L.C., Paneroni M., The Brescia Smart Campus Demonstrator. Renovation toward a zero energy classroom building, *Procedia Engineering*, 118 (2015) 735-743.
21. Tagliabue L.C., Manfren M., De Angelis E., Energy Efficiency Assessment Based on Realistic Occupancy Patterns Obtained Through Stochastic Simulation, in: M.R. Thomsen, M. Tamke, C. Gengnagel, B. Faircloth, F. Scheurer (Eds.) *Modelling Behaviour*, Springer International Publishing (2015) pp. 469-478.
22. Masuda H., Claridge D., Estimation of building parameters using simplified energy balance model and metered whole building energy use, *Proceedings of the Twelfth International Conference for Enhanced Building Operations*, (2012) Manchester, UK, October 23-26.
23. Paulus M.T., Claridge D.E., Culp C., Algorithm for automating the selection of a temperature dependent change point model, *Energy and Buildings*, 87 (2015) 95-104.
24. Lin G., Claridge D.E., A temperature-based approach to detect abnormal building energy consumption, *Energy and Buildings*, 93 (0) (2015) 110-118.
25. Parys W., Saelens D., Hens H., Coupling of dynamic building simulation with stochastic modelling of occupant behaviour in offices – a review-based integrated methodology, *Journal of Building Performance Simulation*, 4 (4) (2011) 339-358.
26. Parys W., Souyri B., Woloszyn M., Agent-based behavioural models for residential buildings in dynamic building simulation: state-of-the-art and integrated model assembly, in: M.R. Thomsen, M. Tamke, C. Gengnagel, B. Faircloth, F. Scheurer (Eds.) *Modelling Behaviour*, Springer International Publishing (2015) pp. 339–358.
27. Bynum J.D., Claridge D.E., Curtin J.M., Development and testing of an Automated Building Commissioning Analysis Tool (ABCAT), *Energy and Buildings*, 55 (0) (2012) 607-617.



## Expanding Boundaries: Systems Thinking for the Built Environment

### STRATEGIC PLANNING FOR THE TRANSFORMATION OF A UNIVERSITY CAMPUS TOWARDS SMART, ECO AND GREEN SUSTAINABLE BUILT ENVIRONMENT: A CASE STUDY FROM PALESTINE

S. Abu-Eisheh<sup>1\*</sup>, I. Hijazi<sup>2</sup>

<sup>1</sup> Department of Civil Engineering, An-Najah National University, P.O.Box 7, Nablus, Palestine

<sup>2</sup> Department of Planning, An-Najah National University, P.O.Box 7, Nablus, Palestine

\*Corresponding author; e-mail: sameeraa@najah.edu

#### Abstract

An-Najah National University in Palestine had decided to include the transformation towards Smart, Eco and Green University as one of the major themes in its strategic plan for 2016-2020. The paper considers the new university campus as the model for planning towards a smart and sustainable built environment. The paper considers the systems thinking approach, taking into account the connections among the various relevant components, to achieve a sustainable built environment on the scale of a university campus. The interaction among the infrastructure components, the built and natural environment, along with the socio-economic and regulatory domains, was considered. The paper presents the strategic planning framework, highlighting the strategic analysis in the fields relevant to the Smart, Eco and Green University theme, conducted through a participatory approach engaging the university professors and administrators, as well as the students. This had assisted to identify the major issues to be considered in the formulation of the university's strategic plan related to the theme, identifying the points of strength and weakness within the internal environment, as well as the opportunities and threats within the external environment. With the most important thematic major issues identified through participatory approaches, and considering the university's vision and mission, the relevant interventions were identified. The paper highlights the key aspects in devising the resulting strategic plan, including the action plan, and summarizes the lessons learned.

#### Keywords:

Sustainable Built Environment; Strategic Planning; Smart University

## 1 INTRODUCTION

The goal of this paper is to present the strategic planning efforts that had been made over more than a year towards transforming the university science and technology campus of An-Najah National University in Palestine into a smart, eco and green built environment. These were part of the efforts made to prepare the third strategic plan for the university for 2016-2020.

An-Najah National University, the largest public university in Palestine, has decided to lead in providing a prototype model of a small smart and sustainable city in the region, through adopting the smart city concept for achieving a sustainable built environment. Such a transformation is

envisaged to result in better asset maintenance and management, a reduction in the operational expenses and the consumption of resources (such as those related to energy, water, and heating/air conditioning), protection of the environment, and improving the quality of the living environment, through the use and adaption of advanced technology.

## 2 SMART AND SUSTAINABLE BUILT ENVIRONMENT

### 2.1 Smart city concept

The 21st century is being recognized as the city century [1]. Statistics show that today more

people live in urban areas than in rural environments, while in 2050, urban population will reach 70% [2]. In Palestine, recent statistics indicate that urban population reached 74% [3]. The socio-economic, environmental, and engineering challenges posed by this transformation will shape the societies of the 21st century. Therefore, there is a need for efficient urban management and sustainable development, mainly envisaged to be achieved utilizing “smart” technologies and technological innovations.

Smart city is a recently developed concept to highlight the growing importance of information and communication technologies (ICT) in profiling the competitiveness of cities [4]. Major technological, economic and environmental changes have generated an interest in smart cities. Sectors that have been developing smart city technology include transport and traffic management, energy, water and environmental utilities, as well as the building sector.

The aim is to establish new cities and develop existing ones on the bases of sustainability. Therefore, developing a smart city concept can support an efficient urban management and a sustainable development, by the use of “smart” technologies, which can improve the efficiency and effectiveness of urban systems.

## 2.2 Smart university concept

Research in the field has focused on components of urban services or on enhancing the learning environment [5] [6]. Less has been done on the systems thinking approach across the city by integrating various urban system services (transportation, electricity, street and public lighting, water supply, sanitation, etc.) and interactions with stakeholders, mainly the users [7].

In this paper, the approach followed to consider systems thinking in demonstrating the attempt of the university to experiment on the scale of a small town (a large university) by treating the technical components of the city (infrastructure networks, built environment, and natural environment). This is a unique experiment in the region, as it deals with the systems at large, and considers, the socio-economic and regulatory aspects, during the course of preparing the university's five-year strategic plan.

## 3 STRATEGIC PLANNING AS A TOOL TO DEVELOP SMART BUILT ENVIRONMENT

To achieve a sustainable development, strategic planning has been conducted. Strategic planning helps to see the larger picture of the situation and assists in achieving the desired objectives.

Through strategic planning, community change can be planned in an effective way for

stimulating, developing and managing goals determined by the community itself. Strategic planning is a demonstration of how the community can identify its mission and vision and change the environment to achieve its objectives.

Therefore, strategic planning provides a framework to achieve the smart built environment concept. The followed strategic planning approach assists in the systematic decision-making, focusing attention on important issues and how to resolve them. Therefore, the process provides a general methodological framework to determine priorities, make wise choices, and allocate scarce resources (mainly money and time) to achieve agreed upon objectives.

A participatory strategic planning approach is followed, which can be described as a holistic process that directly and meaningfully engages the university body, including the university academic and administrative community, as well as the student community, to identify and choose interventions to achieve the university vision, and ensure that these are well selected and reflect the best use of resources.

Urban strategic planning has been seen as a means to control, regulate and determine the directions of the development of a city or urban area, in the context of its current profile and future opportunities and challenges. The systematic assessment of Strengths, Weaknesses, Opportunities, and Threats, or SWOT Analysis, is one of the most widely used strategic assessment approaches. Strategic assessment is followed by a process of identifying the highest priority issues, formulating the vision and mission, and defining goals and objectives. Consequently, the interventions, or strategies, are devised to define what needs to be done, when, and how to achieve the stated goals and objectives.

## 4 THE CASE STUDY SETTINGS

### 4.1 Overview

The An-Najah National University new campus is constructed on 126 thousand square meters of land in the western part of Nablus City, located in the heart of the northern region of the West Bank of the occupied Palestinian territories.

The university enrolment is currently about 25 thousand students, distributed over four campuses. The new campus hosts about half this number. The new campus was planned to be a base for science and technology in Palestine, as it houses the faculties of sciences, medicine and health sciences, and engineering and information technology. In addition, it hosts the faculties of graduate studies, law and fine arts. It also accommodates a theatre, a mosque, a centre of IT excellence, the scientific centre's complex, a



library and media centre, as well as sports and student activities complexes.

Although construction works started 15 years ago in building the new campus, efforts continue to satisfy the developmental needs. Currently, the total built up area has reached a total of about 70 thousand square meters, while the total lengths of urban infrastructure systems has reached about 20 thousand meters. Figure 1 shows the Master Plan of the university's new campus.

#### 4.2 University strategic planning

The university had prepared its first strategic plan in 2005 to cover the five year period from 2006 to 2010. The university formed a Steering Committee in the fall of 2014 to oversee the preparation of its third strategic plan for the period from 2016 to 2020.

The administration of the university has decided to start transforming it towards being a smart and sustainable campus as a demonstrator for a Smart and Sustainable City, with a vision to provide a secure, environmentally safe, green, and efficient urban centre of the future.

The Steering Committee was designated to plan and oversee the activities related to the formulation of the strategic plan. The Steering Committee defined 10 themes that have been integrated under four major areas: the academic area, the scientific research area, the community service area, and the institutional support area.

Under the institutional support area, the new theme of the Smart, Eco and Green University was set. The Steering Committee formed a specialized sub-committee to diagnose the current situation related to the theme topics. The sub-committee included professors in planning, transportation, energy, water and environment, building engineering, information technology, socio-economic sciences, as well as the university's new campus senior engineer in charge of operations and maintenance.

## 5 STRATEGIC PLANNING FOR A SMART, ECO AND GREEN UNIVERSITY

### 5.1 Diagnostic study

Strategic assessment was done first in the fields relevant to the Smart, Eco and Green University theme, which include the infrastructure, the built environment, and the natural environment. Moreover, an inter-disciplinary area was considered, which is related to the economic, social/behavioural, and regulatory aspects [8].

The infrastructure field included the transportation, wet utilities and environmental systems (water, wastewater, storm water, irrigation, and solid waste), electricity and energy, and data and telecommunication systems.

The built environment field considers all the campus buildings, with concentration on the buildings' systems, with emphasis on water and environmental utilities, heating/air conditioning, data systems, electricity and energy.

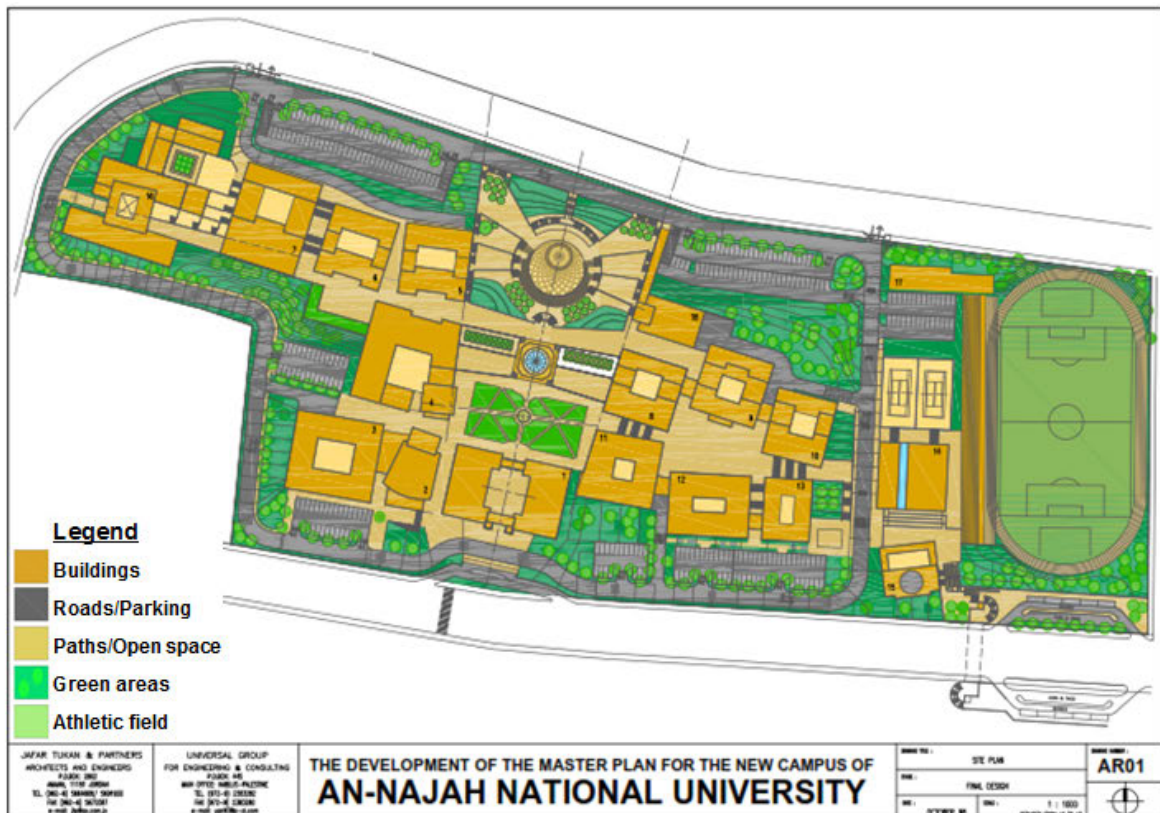

Fig. 1: University new campus Master Plan.

The natural environment field considers all the outdoor facilities, with emphasis on the open spaces and green areas.

The SWOT analysis was conducted in order to identify the points of strengths and weaknesses, as related to the internal environment, and the opportunities and threats, as related to the external environment.

Based on the outcome of the strategic assessment stage, a diagnostic report that presents the results of the diagnosis was prepared by the Steering Committee. Each sub-committee, using both historical and current data as well as the situation assessment, had identified the potential key issues to be considered in the strategic plan.

### 5.2 Identifying major issues

To prioritize the key issues in each theme, the Steering Committee held a participatory workshop to present the report, and discuss with the participants the important issues across the fields to derive the most important issues to be considered in the strategic plan. The participants included the university administration, the deans of faculties, and the heads of academic departments, administrative units, and research and community service centres.

In the workshop, and after presenting the diagnostic report, the attendants were divided into groups, and each ranked all the issues according to priority. Based on that, the ranked priorities of the key issues across all the sectors were identified.

The issues that were selected to be those of high priority and to be considered in the preparation of the strategic plan interventions included, under the theme of Smart, Eco and Green University, the following, which were selected from the defined ten thematic relevant issues:

- Lack of a proper infrastructure and building management systems, especially for the wet and environmental utilities
- Traffic congestion at the vicinity of the campus and the inappropriate public transportation and parking facilities
- Insufficient use of potential renewable energy to satisfy the increasing demand

In addition, the sub-committee that was later formed for the ICT has identified ten other issues, where the high priority issue chosen in the workshop was the lack of a well-developed ICT infrastructure system, including the wireless communications.

### 5.3 Defining goals and objectives

In order to address the identified top priority issues in the Smart, Eco and Green University theme, as well as the theme of ICT, the related sub-committees had further analysed the issues and conducted a root-cause analysis to trace the

issues/problems to their origin, and to facilitate arriving at the strategic goals and objectives that would address the identified issues. The defined strategic goals and objectives were specified for each of the identified issues of top priority.

### 5.4 Specifying interventions

Once strategic goals and objectives were defined, the interventions (programs, projects, and activities), were then specified. Alternate interventions were proposed and assessed, and the most appropriate and efficient interventions were selected.

After the most appropriate interventions (or strategic alternatives) had been agreed upon and formulated, these were then operationalized and included in the grand five-year action plan. It was necessary to meet with the university administration and get endorsement of the Board of Trustees on the strategic interventions, in order to maintain the commitment and secure necessary resources.

Each of the interventions was briefly defined, providing a summary description of the intervention, its linkage with the university strategic plan goals, intervention's activities and/or components, cost per activity/component, time frame for implementation, and responsibility for implementation and follow up.

### 5.5 Devising the action plan

Based on the identification of the strategic interventions, the action plan was prepared. This plan establishes what must be done, the date by which it will be done, and who will be responsible for the implementation. The action plan needs to be implementable within the existing or foreseen limitations of budgets, time, and institutional capacity. The Steering Committee prepared the estimated cost of the strategic plan interventions. Such cost was set considering potential allocations, taking into account the past five year developmental expenditures. A summary of the costs of the implementation of the interventions specified under the themes of the smart, eco, and green university, as well as the ICT, are presented in Table 1.

The overall costs are estimated at 6.991 million USD, including 5.791 million USD under the theme of the smart, eco, and green university, and 1.2 million USD under the ICT theme.

The major cost items concentrated on transforming the infrastructure to be capable of serving the continuous data collection on the operation and performance of the transportation, wet utilities, energy, and lighting systems, and to implement relevant smart, eco, and green projects. These included equipping the infrastructures with sensors and communication networks, implementing a major solar energy harvesting project, and implementing a major

public transportation and parking improvement program using smart technologies.

Moreover, the overall costs included the implementation of the first phase to transform the internal systems, including water, energy, and lighting systems, in two buildings towards sustainable and smart buildings. The costs included also implementing a program for the development of green areas and open spaces. Finally, the costs included awareness programs to engage the students and faculty in the wise use of resources aim, in order to complement the physical related interventions.

In addition to the above indicated interventions, the action plan included the allocation of 2 million USD for the development of the ICT infrastructure in the university. It is estimated that 60% of this cost will be allocated to the new campus. Therefore, it is estimated that 6.991 million USD will be spent to transform the new campus to be smart, eco and green.

### 5.6 Strategic plan approval

The Board of Trustees has studied the strategic plan and adopted it with its components and budget. The smart, eco and green university theme, along with the ICT infrastructure theme, formed about 33.9% of the whole cost of the strategic plan cost of 22.965 Million USD, extending over the strategic plan's five-years.

No.	Field/sector	Sub-sector	Cost (1000* USD)
1.	Infra-structure	- Water and Environment - Energy - Transportation	1,303 500 3,503
2.	Built Environ-ment	- Pilot Smart Energy and Utilities in Buildings	160
3.	Natural Environ-ment	- Green Areas and Open Spaces	265
4.	Social/ Behavior/ Economic	- Awareness Programs	60
5.	ICT	- Development of the ICT infrastructure	1,200
	Total		6,991

*Table 1: A summary of the interventions under the smart and sustainable university relevant themes for the new campus.*

The Board of Trustees requested that the university administration should consider a close follow up of the implementation of the approved interventions. The Steering Committee was therefore delegated the authority to follow up the

implementation of the strategic plan, through the already prepared monitoring and evaluation framework. This framework had included well-identified key performance indicators, which were specified for each of the interventions over the five years of the plan, to facilitate monitoring and the evaluation of the progress towards achieving the objectives.

It has to be stated that by the start of the year 2016, executive sub-committees were formed to implement the interventions, including three sub-committees for the Smart, Eco and Green, as well as the ICT themes.

## 6 CONCLUSIONS

This paper presents the planning efforts conducted towards the preparation of the strategic plan for An-Najah National University in Palestine, which included the intention to transform the new science and technology campus towards Smart, Eco and Green built environment. The adopted related interventions were meant to demonstrate how a "small city" can be transformed to be smart and sustainable. The experiment once judged to be successfully implemented, is envisaged to be benefited from and repeated in other cities in the country and in the region.

By the end of the plan's five years in 2020, all the infrastructure systems would have been converted to be "smart". Eco and green university natural environment objective should have been realised. It is hoped that the pilot smart energy and utilities in buildings sub-sector included in the plan would be successful, encouraging to move ahead towards implementation to other buildings as appropriate, transforming the built environment to be smart and sustainable.

Despite the seemingly high investment by a university in an emerging country in the theme, it is envisaged that such high cost would pay back. Tangible benefits are foreseen on fronts related to the proper asset and maintenance management, reduction of operational expenses and resource consumption, protection of the environment and improving the quality of the living environment.

The university administration and Board of Trustees commitment to transform the new campus towards a Smart, Eco and Green Sustainable Built Environment was essential. Without such commitment and provision of the necessary resources, the efforts towards the realization of such an aim would not have started.

## 7 REFERENCES

1. Ratcliffe J., and E. Krawczyk, *Imagining Cities: Creating Liveable Urban Future in the 21st Century* (2004), in *Thinking Creativity in Turbulent Times*, Didsbury, H., ed., World Future Society: Bethesda, MD, USA.
2. United Nations, *World Urbanization Prospects, The 2007 Revision* (2008: The Department of Economic and Social Affairs, New York, USA).
3. Palestinian Central Bureau of Statistics, *Housing conditions related to Sustainable Development in Palestine*.  
<http://www.pcbs.gov.ps/site/512/default.aspx?tabID=512&lang=en&ItemID=1511&mid=3171&wversion=Staging>  
 Accessed on Dec. 15, 2015.
4. Murray, A., Minevich M., and A. Abdoullaev, *The Future of the Future: Being Smart about Smart Cities*. KM World, 2011. 20 (9).
5. Tikhomirov, V., *Development of strategy for smart University* (2015), in *Open Education Global Conference, 2015*, Open Education Consortium, Banff Calgary, Canada.
6. Nuzzaci, A., and L. La Vecchia, *A Smart University for a Smart City*, 2012. *International Journal of Digital Literacy and Digital Competence*, 3 (4): Hershey, PA, USA.
7. Shahrour, I., *SunRise Smart City "Large Scale Demonstrator of the Smart and Sustainable City"*, in *International RFID Congress, 2015, Smart Objects for Industry, Retail, Healthcare and Smart Cities: Marseille, France*.
8. An-Najah Nation University, *University Strategic Plan 2016-2020*. 2016: Nablus. Palestine.



## Expanding Boundaries: Systems Thinking for the Built Environment

### INTRODUCTION OF A DYNAMIC INTERPRETATION OF BUILDING LCA RESULTS: THE CASE OF THE SMART LIVING BUILDING IN FRIBOURG, SWITZERLAND

E. Hoxha<sup>1\*</sup>, T. Jusselme<sup>1</sup>, M. Andersen<sup>2</sup>, E. Rey<sup>3</sup>

<sup>1</sup> Ecole Polytechnique Fédérale de Lausanne (EPFL), Building 2050 Research Group, Fribourg, Switzerland

<sup>2</sup> Ecole Polytechnique Fédérale de Lausanne (EPFL), Interdisciplinary Laboratory of Performance-Integrated Design (LIPID), School of Architecture, Civil and Environmental Engineering (ENAC), Lausanne, Switzerland

<sup>3</sup> Ecole Polytechnique Fédérale de Lausanne (EPFL), Laboratory of Architecture and Sustainable Technologies (LAST), School of Architecture, Civil and Environmental Engineering (ENAC), Lausanne, Switzerland

\*Corresponding author; e-mail: endrit.hoxha@epfl.ch

#### Abstract

Although a building's lifetime is not predictable, it is an essential data in the yearly impact calculation. Yet, in the assessment of the environmental impacts of buildings, the lifetime is considered as a fixed value.

The purpose of this study is to introduce a new dynamic interpretation of LCA results which aims at improving the reliability of assessments of buildings' environmental impacts.

To that end, are compared:

- the environmental impacts assessed for 50, 70 and then 100 years of the building's lifetime
- and environmental impacts assessed for anytime during the first 100 years of the building's lifetime

Since the impacts depend on the type of the building's components and their quantity, in this study two scenarios have been applied: one compares two building projects that differ from each other on the shape and functionality; the other compares two projects that differ only in components and systems employed in the building. Possible projects of the smart living building have been selected as case studies. This building aims at reaching the goals of the 2000 watt society vision and will be built by 2020 in Fribourg, Switzerland. The dynamic interpretation of building's impacts shows that the LCA results could vary up to 20%, according to the assumed building's lifetime and thus, completely change the conclusion in the comparison of the impacts of different building projects when the projects differ from the components and systems. The dynamic interpretation assessed more reliable LCA results, that are useful for strengthening comparisons in the decision making process.

#### Keywords:

Dynamic LCA; Building; Lifetime

## 1 INTRODUCTION

It is well known that buildings are counted as responsible for 40% of global energy use, and as much as one third of global greenhouse gas emissions. But what is particularly worrying is the rate of growth of emissions. Under the IPCC's

growth scenario, by 2030 the environmental impacts incurred from buildings will be doubled [1].

To prevent such a scenario and to aspire towards a sustainable and equitable use of the world's raw materials, the Swiss Federal Institute of Technology promoted the vision of a "2000 watt

per capita society". According to this vision, today's impacts of primary energy, nonrenewable energy and greenhouse gases should be reduced respectively by a factor 2, 3 and 4 by the year 2050 [2, 3]. Because buildings play a key role in the global energy use and greenhouse gas emissions, the assessment of the environmental performance is important in new constructions for communicating their influence on sustainable development. For more than 20 years, the life cycle assessment (LCA) method has been used as the tool for the assessment of the environmental impacts of buildings. Based on ISO-14040 [4], LCA methodology consists of four distinct analytical steps: defining the goal and scope, creating the lifecycle inventory, assessing the impact and finally interpreting the results.

In the literature a large number of studies can be found where the LCA methodology has been used for the assessment of the environmental impacts of buildings. The objectives, the methodological issues as well as the buildings' cases are quite variable from one study to another [5]. According to the LCA method, the studies differ in general from each other as a function of the boundaries of the study (the components and systems of buildings taken into consideration), the database used for calculation, the functional unit of the building (description of the building: functionality, work hours and conditions of use) or the lifetime of the building. The lifetime is determined by how long the building lasts or is useful.

In the ensclic Building project [6], for the assessment of the environmental impacts of four houses, nine residential buildings and five offices, the lifetime is considered to be 50 years. Hoxha [7] has considered a lifetime of 60 years in the assessment of the environmental impacts of 16 houses and 16 residential buildings. In the HQEperformance [8], the environmental impacts of 24 offices, 17 residential buildings and 22 individual houses were assessed for a building lifetime equal to 50 years and 100 years.

Depending on the type of building, in literature its lifetime varies from 25 to 100 years. Generally, the building's lifetime is considered to be 50 years, but there is also a certain number of studies where the lifetime is considered to be 70 or 100 years [9]. Although a building's lifetime is not predictable, it is essential data in the yearly impact calculation by having a preponderant influence in the reliability of the results calculated [10]. Thus, the research hypothesis of this paper is that we should not limit the assessment of buildings' impacts to one or two buildings' lifetime, but provide a LCA for any years of its lifetime in order to enhance the robustness of the conclusions. This approach is what we call a dynamic interpretation.

## 2 METHODS

To introduce the dynamic interpretation of LCA results, we have compared:

- environmental impacts assessed for a building lifetime equal to 50, 70 and then 100 years
- environmental impacts assessed for anytime during the first 100 years of the building lifetime

In the early design phase the scenarios of buildings can differ from each other, from the components and systems employed and the shape. Due to that, in this study two scenarios have been applied: one compares two building projects that differ from each other only by the shape and functionality; the other compares two projects that differ only by the chosen components and systems.

The assessment of impacts is undertaken according to European standard EN-15978 [11]. This standard proposes to calculate the environmental impacts of a building in accordance with its life cycle phase: production, construction, use, exploitation and end of life.

### 2.1 Goal and scope definition

The smart living building has been chosen as the most appropriate case study. This building aims at reaching the 2050 goals, according to the 2000-watt society vision and will be built by 2020 in Fribourg, Switzerland. Two possible architectural scenarios are considered in this study as presented in Figure 1.



Fig. 1: Two possible projects of smart living building.

The first scenario (PR-1) has an expected energetic reference area of around 6200 m<sup>2</sup> (2000 m<sup>2</sup> of houses; 1200 m<sup>2</sup> of experimentation areas; 2700 m<sup>2</sup> of offices; 300 m<sup>2</sup> of other) and the second (PR-2) around 4000 m<sup>2</sup> (1250 m<sup>2</sup> of houses; 750 m<sup>2</sup> of experimentation areas; 1500 m<sup>2</sup> of offices; 500 m<sup>2</sup> of other). Wood is the main material used in both scenarios (PR-1 and PR-2) that differ from each other only by the shape and functionality. A third scenario PR-1/A considered in this study has the same shape as PR-1 but the main material used is reinforced concrete. More details about the components and systems used in these three scenarios are presented in Table 1. All the phases of the building's lifecycle are considered in the assessment of the impacts of the building.

### 2.2 Inventory

#### A1–A3: Production phase

In the production phase the whole process of the extraction of raw materials from the earth is

included, as well as transportation to the factory, production of the building's components and systems.

#### A4 & A5: Construction phase

In this module, the transportation of components and systems to the site of construction is considered. The distance of transportation from the factory to the site of construction of components and systems of buildings are presented in table 1 and 2. These values are inspired by Lehman [12]. The amount of materials of the production phase are increased by 5% for considering the process of construction, but the energy consumption at the site has not been considered.

#### B1–B5: Use phase

The process of maintenance, repair, replacement and refurbishment, are included within the use stage. Based on the lifetime of a building's components and systems presented in table 1 and 2, the maintenance and the number of replacement rates are calculated according to standard EN-15978 [11]. The process of repair is considered to be every 50 years. Here we consider that 10% of materials and components with a lifetime equal to that of the building will be repaired.

#### B6 & B7 Exploitation phase

In this module we include energy and water consumed during the use phase of the building for heating, cooling, ventilation, hot water, lighting and appliances. More details about these inputs can be found in Jusselme et al. [15]. The energy consumed in the exploitation phase is simulated in a dynamic regime using the software Lesosai software [16]. The results obtained are presented in Table 2. The electricity produced by the PV panels is used for covering the need of electricity for lighting, ventilation and appliances.

#### C1–C4 End of life

Based on the KBOB [13] database, the whole end-of-life process (demolition of the building, transportation of materials to the recycling site, treatment or elimination of materials) is considered in the study.

### 2.3 Impact assessment

The environmental impacts are assessed with the help of the KBOB database [13]. The KBOB code presented in table 1 and 2 provides information about inputs used for assessing the impacts of each material and system. Only the global warming potential (GWP) indicator is calculated in this study.

Inventory data	Quantity of components and systems				Trans (km)	Lifetime (year)	KBOB (code)
	Unit	PR-1	PR-2	PR-1/A			
Excavated land	m <sup>3</sup>	955	idem	idem	20	LB *	62.001
Gravel	kg	168320	idem	idem	200	30 *	3.012
Gravel	kg	42000	idem	idem		50 *	
Poor concrete	m <sup>3</sup>	22.83	idem	idem	80	LB *	1.005
Concrete CEM II	m <sup>3</sup>	45.62	18.78	112.15		50 *	11.005
Concrete CEM II	m <sup>3</sup>	6.87	idem	idem		LB *	1.013
Concrete CEM III	m <sup>3</sup>	27.5	idem	idem		LB *	
Cellular concrete	kg	24596	idem	idem		LB *	2.006
Fired clay	kg	-	-	162012		LB *	2.001
Mortar	kg	3024	idem	idem		15 *	4.001
Mortar	kg	-	-	63983		40 *	
Mortar	kg	72135	69123	15850		50 *	4.002
Mortar	kg	-	-	5072		LB *	4.001
Steel	kg	704.4	388	9157	130	40 *	6.003
Galvanized steel	kg	16272	10795	6492		LB *	6.011
Reinforcing steel	kg	1650	1650	66643	80	LB *	6.003

Table 1: Inputs used for the calculation of impacts (lifetime of materials and systems inspired from KBOB database [13] and HOXHA et al [14]\*). LB-Lifetime of building.

Inventory data	Quantity of components and systems				Trans (km)	Lifetime (year)	KBOB (code)
	Unit	PR-1	PR-2	PR-1/A			
Hardwood	kg	28126	25775	-		25 *	7.013
Hardwood	kg	751	557	-		30 *	
Hardwood	kg	15620	7732	9573		40 *	
Hardwood	kg	1084	615	-		45 *	

Hardwood	kg	281123	300997	90456	130	LB *		
Chipboard OSB type	kg	163744	127205	63469		LB *	7.008	
Cellulose fibre	kg	68618	509430	26321		LB *	10.01	
Parquet flooring	kg	7022	4210	5680		50 *	11.011	
Bituminous waterproofing	kg	277	277	277	1000	15 *	9.003	
Bituminous waterproofing	kg	9258	9258	13099		30 *		
Adhesive	kg	32	23	14		50 *	8.001	
Sanitary ceramics	kg	6425	1722	4259	80	60 *	3.014	
Expanded polystyrene	kg	504	504	504	380	15 *	10.004	
Expanded polystyrene	kg	-	-	12397		40 *		
Glass wool	kg	2525	idem	idem		30 *	10.001	
Glass wool	kg	2254	1683	-		40 *		
Glass wool	kg	4195	2260	4195		LB *		
Polyurethane	kg	-	-	31027		40 *	10.006	
PVC	kg	880	idem	idem	200	50 *	13.004	
Plaster cardboard	kg	145070	79496	132577	1000	40 *	3.008	
Reinforced plaster	kg	78656	42388	78656		LB *	3.007	
Polyethylene	kg	259	142	-		25 *	9.007	
Polyethylene	kg	321	315	-		30 *		
Wood paint	kg	2520	1549	89		10 *	14.001	
Wood paint	kg	2040	1602	756		25 *		
Steel paint	kg	0.94	0.64	0.33		25 *	14.006	
Carpet	kg	3106	2840	-		10 *	11.024	
Doors	m <sup>2</sup>	253	137	253		100	45 *	12.001
Windows (20% wood frame)	m <sup>2</sup>	1409	1056	-			30 *	5.002 & 5
Windows (15% aluminium frame)	m <sup>2</sup>	-	-	1409	40 *		5.002 & 4	
Heat distribution, residential	m <sup>2</sup> SRE	1927	1460	1927	-	25	31.021	
Heat distribution, administration		3757	2438	3757		25	31.022	
Heat production 30 W/m <sup>2</sup>		5685	3898	5685		25	31.002	
Office ventilation sheet metal channels (2m <sup>3</sup> /h)		3021	2800	-		15	32.005	
Air exhaust kitchen and bathroom		105	30	-		15	32.003	
Sanitary equipment of offices		120	77	120		25	33.001	
Sanitary equipment of residential		110	74	110		25	33.003	
Electrical equipment of offices		3163	2438	3163		25	34.002	
Electrical equipment of residential		2521	1460	2521		25	34.001	
Solar collectors		m <sup>2</sup>	102	57		100	25	31.009
Photovoltaic panels	kWp	161	137	161	25	34.027		
Space heating	MJ/m <sup>2</sup> SRE	72.5	130	72.5	-	In function of lifetime of building	42.003	
DHW		12.3	13.1	12.3			42.003	
Electricity for ventilation		14	16	14			45.020	
Electricity for lighting		22	18	22			45.021	
Electricity for appliances		59	5	59			45.022	
PV panels		70	39	70			-	

Table 2: Inputs used for the calculation of impacts (lifetime of materials and systems inspired by the KBOB database [13] and HOXHA et al [14]\*). LB-Lifetime of building.

### 3 RESULTS

The results of the GWP indicator of PR-1 are presented in Figure 2. Comparisons of the CO<sub>2</sub>-eq emissions with the 2050' goal [3] shows that the project reaches the objectives for 50, 70 and 100 year building's lifetime. The building has lower impacts per year when the building's lifetime is considered 100 years instead of 50 years, but

higher impacts for a building's lifetime equal to 70 years. At the same time the results confirm that the impacts of building life cycle phases vary in function of its lifetime. For a building's lifetime equal to 50 years, the results show that the production phase (A1-A3), and exploitation phase (B6-B7) have the same weight. But this is not true for a building's lifetime of 100 years, where the use



phase (B1-B5) has the biggest weight, and is around three times bigger, compared to the production phase (A1-A3).

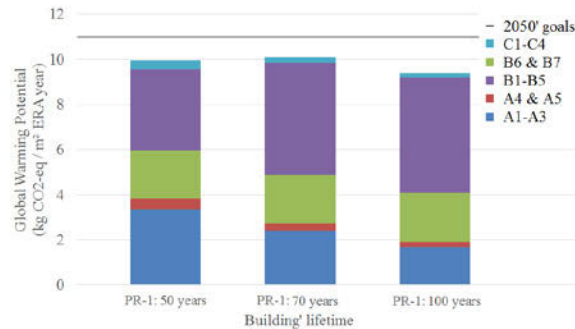

Fig. 2: CO<sub>2</sub>-eq emissions on the 50<sup>th</sup>, 70<sup>th</sup> and 100<sup>th</sup> year of the buildings.

To better understand the impacts of a building life cycle phase, the CO<sub>2</sub>-eq emissions are calculated for anytime during the first 100 years of a building's lifetime. These calculations represent a dynamic way of interpreting the results. The observation of results presented in Figure 3 shows that the phases of buildings can be classified in three groups. In the first group we can classify the phases (A1-A5 & C1-4) for which the impacts per year decrease by increasing the building's lifetime. In the second group we classified the exploitation phase (B6 & B7) for which the impacts are constant for all buildings' lifetimes. And in the third group we can classify the phases (B1-B5) for which the impacts per year rise by increasing the building's lifetime. At the same time the results show that the lifetime of the building can significantly influence the ability to reach fixed objectives in very efficient buildings. For a lifetime of up to 20 years, the impacts of a building per year are strongly decreased by the influence of its lifetime. For a lifetime between 20 and 75 years the impacts of a building are lightly decreased by the influence of its lifetime, and for values higher than 75 years the building's lifetime doesn't have any significance influence.

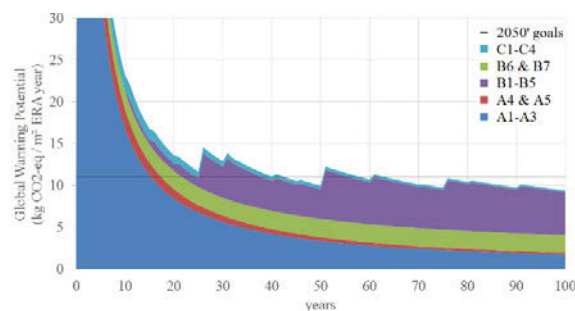

Fig. 3: CO<sub>2</sub>-eq emissions during the first 100 years of the building's lifetime.

It seems that the building reaches the 2050' goals for a building's lifetime between 45-50 years and 60 years. Assuming such a building's lifetime in the yearly impact calculation brings to no reliable

conclusion, because in reality the building can last 55 years.

For a building's lifetime greater than 65 years we can conclude that the building has reached the objectives. Only starting from a 65 year lifetime the environmental impacts of buildings are always lower than the 2050' goals.

The dynamic interpretation of the results influences also the decision making process. In Figure 4 we present the comparison of impacts of two building scenarios different from each other only by the shape.

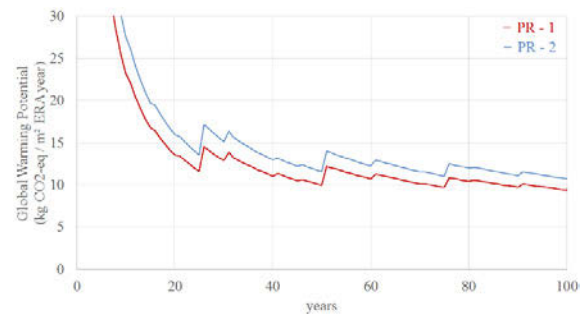

Fig. 4: Comparison of dynamic CO<sub>2</sub>-eq emission of two building projects that are different from each other only by the shape and functionality.

Two interesting results can be obtained from Figure 4. First, we can observe that the shape that affect also the functionality of a building has a significant influence on the impacts of a building, even if the performance is evaluated per m<sup>2</sup> of the energetic reference area (ERA). For the scenarios presented in this study, the shape and functionality can reduce the impact by 15% for the unit kg CO<sub>2</sub>-eq/m<sup>2</sup> ERA year. Secondly, the results show that the dynamic interpretation of results has no influence on the decision making process when the building's scenarios are different by the shape and functionality. The scenario that has lower impacts will always be the best solution whatever the value of the building's lifetime is. In Figure 5, the environmental impacts of two scenarios are presented that differ from each other from the building's components and systems.

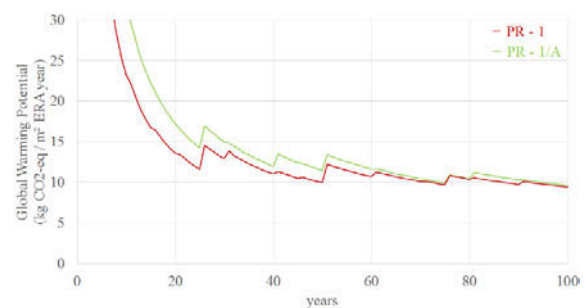

Fig. 5: Comparison of dynamic CO<sub>2</sub>-eq emission of two building projects that are different from each other only by the chosen components.

The results obtained show that the PR-1 does not always have lower impacts compared to those of

PR-1/A, even though the difference of impacts were 20% at a 25 year lifetime of the building. The results show that starting from 60 years of building's lifetime, the impacts of the two scenarios are not significantly different.

#### 4 CONCLUSIONS

The dynamic interpretation of building LCA results is a powerful way to better understand the environmental impacts of buildings. It shows the progression of buildings' impacts over time and helps the LCA-practitioner to understand in which phase and in which period of the building they should focus efforts for minimizing impacts.

An unexpected outcome of the study was the intersections of the environmental impacts of building projects. In the comparison of environmental impacts of two building projects, the one with lower impacts for a certain lifetime will not have always lower impacts for other values of lifetimes. So the main usefulness of the dynamic interpretation of LCA results is to identify these intersections. It strengthens the reliability of comparisons of scenarios in the decision making process and should therefore be used.

Further developments are necessary to set up the methodology for comparing scenarios with intersected environmental impacts.

#### 5 REFERENCES

1. UNEP SBCI. Sustainable Buildings & Climate Initiative. Buildings and Climate Change: Summary for Decision-Makers. 2009. United Nations Environment Programme.
2. Jochem E., et al., Step towards a sustainable development: A white book for R&D of energy-efficient technologies. 2004. Novatlantis.
3. SIA 2040. La voie SIA vers l'efficacité énergétique. 2011. Société des ingénieurs et architectes. Zürich.
4. ISO 14040. Environmental management - Life cycle assessment - Principles and framework. 2006. International standard.
5. Ramesh, T., et al., Life cycle energy analysis of buildings: An overview, 2010. Energy Building: 42(10) 1592-1600.
6. CIRCE. Energy Saving through Promotion of Life Cycle Assessment in Building. 2010, enslic Building, Europe.
7. Hoxha, E. Amélioration de la fiabilité des évaluations environnementales des bâtiments. 2015, PhD thesis. Université Paris-Est.
8. Lebert, A., et al., Capitalisation des résultats de l'expérimentation HQE Performance. 2013 : Rapport intermédiaire, CSTB, France.
9. Ghattas, R., et al. Life cycle assessment for residential buildings: A literature review and gap analysis. 2013, Massachusetts Institute of Technology. USA.
10. Aktas, C. B., and Bilec, M. M. Impact of lifetime on US residential building LCA results, 2012. The International Journal of Life Cycle Assessment, 17(3), 337-349.
11. European Committee for Standardization (CEN). Sustainability of construction works-assessment of environmental performance of buildings-calculation method. 2001, FprEN 15978:2011.
12. Lehmann, U., Analyse du cycle de vie du "Green-Offices". 2011, Université de Lausanne. Switzerland.
13. KBOB et al. KBOB, eco-bau and IPB (2012) Ökobilanzdaten im Baubereich, Stand Juli 2012. Koordinationskonferenz der Bau- und Liegenschaftsorgane der öffentlichen Bauherren c/o BBL Bundesamt für Bauten und Logistik, retrieved from: <http://www.bbl.admin.ch/kbob/00493/00495/index.html?lang=de>.
14. Hoxha, E., et al., Method to analyse the contribution of material's sensitivity in buildings' environmental impact. 2014. Journal of Cleaner Production, 66, 54-64.
15. Jusselme, T., et al. Building 2050: Scientific concept and transition to the experimental phase, 2015. EPFL-Fribourg, Switzerland.
16. E4tech. Lesosai Software, 2008. Available from: <http://www.lesosai.com/en/index.cfm>.



## Expanding Boundaries: Systems Thinking for the Built Environment

### NEST – EXPLORING THE FUTURE OF BUILDINGS

P. Richner<sup>1\*</sup>, R. Largo<sup>1</sup>

<sup>1</sup> Empa, Überlandstrasse 129, 8600 Dübendorf, Switzerland

\*Corresponding author; e-mail: peter.richner@empa.ch

#### Abstract

Energy and climate challenges require a fundamental change regarding the footprint of the Swiss building stock. The living lab NEST is designed to foster the needed acceleration of the innovation process by bringing academia and industry together. NEST consists of a backbone with 2'500 m<sup>2</sup> of innovation area where 12 to 16 research and technology transfer units can be built. Each unit is addressing different challenges such as lightweight construction, adaptive façades, digital fabrication or office of the future. People will live and work in these units to deliver feedback to accelerate the market readiness of new technologies. The units are connected by a multi-energy grid to an energy hub in order to maximise the harvesting and use of renewable energy on site and a water hub to investigate new urban water management solutions. The first two units will go live in spring 2016 and six more units are already under planning and will be completed within the next 2 years.

#### Keywords:

Living lab; innovation process; energy and buildings

### 1 INTRODUCTION

As many other countries, Switzerland has established ambitious goals regarding the future development of the energy consumption and the emission of greenhouse gases. These goals can only be reached if the environmental footprint of the Swiss building stock is dramatically reduced. Presently, more than 40% of the end energy in Switzerland is used in buildings, approximately 40% of the CO<sub>2</sub> emissions are caused by buildings and around 1 t of construction materials are used per capita and year [1]. These numbers are similar to the situation in other developed countries with a comparable climate [2].

Research teams in academia and industry are developing new materials, systems and concepts that have the potential to contribute to the goals mentioned. However, transferring results from research into products is a huge challenge in the construction sector and time to market is typically in the order of 10 years and more. Driving such a long term process needs a lot of dedication, financial resources and proper market conditions. As this is not always the case, many good ideas are abandoned despite the fact that they could be game changers.

A number of reasons are contributing to the slow innovation speed in the construction industry. The sector is highly fragmented with many small companies which have little or no capacity at all to invest into new developments. The current price pressure also seems to affect more the quality of work than the search for new solutions. Current low energy prices inhibit new business models. Probably the most important reason is the risk aversion of clients, especially in the area of buildings. This behaviour is perfectly reasonable since the construction of a building is a very costly investment and the building should last for decades. The use of a new component that has not fully proven its performance under real life conditions is therefore very unlikely.

This paper describes a new approach on how to accelerate the technology transfer from research into the market. This is achieved thanks to a close collaboration between academia and industry in a living lab situation where new ideas and prototypes can be evaluated and made market ready in a holistic approach under close to real life conditions.

## 2 NEST – A DYNAMIC LIVING LAB

The modified concept of technology readiness levels (TRL) as proposed recently by EORTA [3] is well suited to identify the steps in technology transfer which represent the most critical hurdles (see Table 1). Conventional pilot and demonstration programs as the one operated by the Swiss Office of Energy in the area of energy efficient buildings [4] usually start at TRL level 7 or later. However, after the invention phase, the TRL levels 3 to 7 including concept validation, prototyping and incubation are difficult to pass. They need an early involvement of potential industrial partners and one has to pay attention to the added complexity if a new material or component has to fulfil its function not isolated in the lab but in combination and interaction with all other components of a building. On top of that, the role of the user is critical for the validation of many building parts, especially in cases where topics such as energy or comfort are addressed. Typically experiments covering this range are expensive and risky and can therefore not be executed within real construction projects where concrete user demands have to be met.

#	Original TRL class	EARTO
1	Basic principles observed	Invention
2	Technology concept formulated	
3	First assessment feasibility concept & technology	Concept
4	Validation integrated prototype in lab environment	
5	Testing prototype in user environment	Prototyping & incubation
6	Pre-production product	
7	Low scale production demonstrated	Pilot production & demonstration
8	Manufacturing fully tested, validated and qualified	
9	Production and product fully operational	Market expansion

Tab. 1: TRL levels according to EARTO [3].

The research and technology transfer platform NEST (Next Evolution of Sustainable Technology) was created in order to address this challenge: NEST is a living lab where technologies at a low TRL level (4-8) are implemented in so called research and innovation units. People will live and work in these units to deliver feedback to accelerate the market readiness of new technologies.

Another important feature of NEST is the flexibility to tackle different challenges from business and research over time. NEST consists of a central structure, the “backbone” with three free standing platforms that can host 12 to 16

different units on a total area of 2'500 m<sup>2</sup> (see Fig. 1). In addition, the backbone provides the necessary media (electricity, water etc.) for the units. Each unit is planned by a consortium with partners from academia and from industry around a specific topic of interest such as lightweight construction, adaptive façades or digital fabrication. So called innovation objects are added to the different units depending on the interest and challenges of the consortium responsible for the unit.

Once built, units will be scientifically evaluated by the partners and they serve as platforms for new research and innovation projects. All units are designed in such a way that most of the new components can be improved over time as new knowledge is gained from the operation. Once the unit has reached a level of maturity where the key questions have been answered and the technology is ready to be implemented in the market, the unit will be dismantled and replaced by a new unit with a new topic and new challenges.



Fig. 1: Empty NEST backbone.

NEST is connected to the Energy Hub Demonstrator on the campus in Dübendorf. The Energy Hub aims at optimizing energy management at district level and evaluating its influence on the overall energy system. Especially the temporal mismatch between supply of renewable energy and energy demand for buildings and mobility will be addressed. In this respect NEST can be viewed as a vertical district with a number of buildings with different energy systems, demand and load profiles.

A water hub operated by Eawag, the Swiss Federal Institute of Aquatic Science and Technology is also part of NEST and each unit is connected to the water hub. The aim of the water hub is the development of promising solutions to curb water consumption and make use of various substances found in wastewater.

NEST is operated by Empa but it is an open research and technology transfer platform for national and international partners from academia and from industry.

### 3 RESULTS

The NEST backbone is close to completion and first units are already under construction. NEST will start operation in May 2016 and units will be constantly added over the coming years. The key features of the first wave of units is described in this part.

#### 3.1 Meet2Create

Meet2Create is an office unit and will serve as a laboratory for collaboration and work processes. It focuses on the interplay between humans, space and technology. The consortium is led by the competence centre for Typology and Planning in Architecture at the University of Applied Science Lucerne. Industrial partners are coming amongst others from the area of HVAC, office furniture, façade systems, lighting and communication. It is the first unit constructed in NEST and will be ready for operation in May 2016.

The office unit will have three different areas each addressing a specific question related to offices. In the first area, options are explored to reduce the use of HVAC systems to an absolute minimum. This includes the use of sorption based long term energy storage systems. The temperature in this area might fall in winter below the normally accepted values. In cooperation with the users, it will be investigated how such a room could still be used for certain activities of knowledge workers. It might well be that for brainstorming sessions and interactive workshops lower temperatures might even be beneficial and activate the team members.

In a second area, the question of personalized local climate will be addressed. It is well known since the ground breaking work of O. Fanger that the individual preferences regarding the indoor climate have a rather broad distribution. As a consequence, no matter what settings are selected for the indoor climate, a certain percentage of people in an office will feel uncomfortable. Small and decentralized HVAC components have theoretically the potential to provide an individualized local climate according to the preferences of the person working at this specific place. In Meet2Create, the feasibility of this approach will be evaluated and besides the economic cost also the energetic balance of such an approach will be investigated. Theoretically, this could be even more energy efficient since users develop counter strategies if their needs are not fulfilled and usually these strategies are very energy intensive.

The daily activities in offices are very diverse in nature. They range from concentrated individual work to one to one meetings both physically and virtually, workshops with numerous people and presentations. Meet2Create will explore the potential of new office furniture to support this variety of activities and to make a specific office a

multifunctional room. Furthermore, new ways are explored to foster the collaboration between teams which are physically located at different places. The goal is the reduction of the need of travelling which is time and energy consuming.

In addition to these focal points many other things will be included in Meet2Create such as acoustically active panels or energy harvesting systems in façade elements.

#### 3.2 Vision Wood

Vision Wood is a living unit for three persons developed under the leadership of the Laboratory of Applied Wood Materials at Empa and the Chair of Wood Materials Science at ETH Zurich in collaboration with industrial partners from the wood sector. The unit is expected to be operational in spring 2016. Vision Wood is promoting wood as a natural resource for the building industry by adding a new flavour to this material thanks to completely new functions added to wood and the improvement of properties of wood based materials.



Fig. 2: Hydrophobized (left) and untreated (right) wood.

One of the most critical properties of wood is the interaction with water. The uptake of water leads to dimensional changes and it can trigger and/or accelerate the decomposition of the material. The standard solution up to now is the application of coatings but they change the natural appearance of wood and the durability is limited. I. Burgert and his team found a way to make not only the surface of wood hydrophobic but the complete bulk material (Fig. 2) [5, 6]. This opens completely new applications of wood in living rooms, especially in wet areas. The bathrooms will be equipped with sinks made out of hydrophobized wood and also in the kitchen area applications are envisioned.

Other new functionalities that were added to wood in the research groups lately are magnetic wood [7], wood surfaces which are antimicrobial and mineralized wood [8]. All of them will be upscaled for the first time in Vision Wood in order to create tangible objects. Magnetic wood will be used in the kitchen to hold knives on the wall. Wood with an antimicrobial surface [9] can be left untreated otherwise and keeps the pleasing natural appearance of wood. Handrails and similar objects will be fabricated in this manner. Mineralized wood is less prone to fire and

therefore adds to the safety of timber based buildings when critical elements of the construction are made out of this material.

Beech wood is today mainly used for energetic applications and not in building structures due to the strong swelling and shrinking of the material upon changes in relative humidity. Vision Wood is using glued laminated timber elements made out of local beech wood to prefabricate large parts of the unit. This will potentially considerably enlarge the market for beech wood and foster the use of a renewable material at large scale in buildings.

This is only a small part of the long list of innovation objects which will be implemented in Vision Wood. Presently, the work focuses on the upscaling of the laboratory processes in order to produce large scale objects. In the use phase aspects of durability will be in the centre of the work as well as acceptance by the users. Furthermore, the unit is designed in such a way that continuously single components made out of new materials can be added into the unit and depending on the results first products will appear soon on the construction market.

### 3.3 HiLo

HiLo is a two story living unit exploring the potential of ultra-lightweight concrete shells, adaptive façades and automated occupant-centred building systems [10]. The consortium is led by the chairs of Architecture and Structures and Architecture and Building Systems at ETH Zurich.

The double curved roof system of HiLo is extremely lightweight and thin and at the same time it is a multifunctional structure. Flexible thin film solar cells will produce electricity, high performance insulation materials will guarantee the necessary thermal insulation and a hydronic low temperature heating and cooling system will be used to deliver the needed comfort in the unit.

The same concept of multifunctionality and lightweight is used for the floor system. Funicular vaulting allows for a 70% reduction in weight compared to conventional solutions and at the same time buildings systems for heating and cooling and other services can easily be integrated in the system without adding to the floor height (Fig. 3). The floor system consists of prefabricated elements which can be easily assembled on site.



Fig. 3: Integrated funicular floor system [10].

An adaptive solar façade with thin film photovoltaic modules with soft pneumatic actuators for solar tracking and daylight control is part of HiLo as well as an energy concept which aims at zero emissions in operation while providing the highest comfort to the user at the same time. The construction of HiLo will start in the second half of 2016.

### 3.4 Solar Fitness and Wellness

Fitness and wellness constitute a growing need in our society but at the same time they contribute to the ever raising energy demand. The unit Solar Fitness and Wellness has the ambition to provide the services required without relying on fossil energy. The team lead by researchers at Empa and NTB Buchs developed a concept where high temperature services required in a sauna are delivered mainly by renewable energy.

The core idea is the use of a high temperature CO<sub>2</sub> heat pump which is able to provide the heat for the sauna and steam room around three times more efficiently than conventional systems. Furthermore, the heat is subsequently used for services with lower operation temperature: sauna at 90°C, bio sauna at 55°C, steam room at 45°C, warm water for showers at 45°C and finally low temperature heating of the unit around 30°C. This cascade adds to the overall energy performance of the unit.

The unit will also become a role model for sustainable water management. Rain water will be used where appropriate, grey water is recycled in a controlled way and nutrients will be recovered from urine. All of this will be part of the water hub operated by Eawag. The unit is expected to go live towards the end of 2016 and it will add to the quality of life on the campus.

## 4 CONCLUSIONS

The challenges that the building stock is facing can only be met if the innovation speed accelerates dramatically in the future. This can be achieved if the time used to pass the intermediate TRL levels from 3 to 8 is decreased. NEST offers this opportunity by bringing partners from research and practice together and let them develop, validate and improve new materials,

systems and concepts in a close to real life environment. Key assets of NEST are the possibility to take far higher risks than in a conventional construction project, the scientific evaluation of all projects and the integration of users in the process.

Although NEST will only become operational in spring 2016, a first evaluation of the basic concept turns out very positive. Four research and technology transfer units will be constructed in 2016 and four more units are already under planning in the area of urban mining, digital fabrication, solar office and assisted ambient living. This clearly shows the interest of partners from academia and industry in such a platform. Furthermore, the network of NEST partners proves to be an extremely valuable asset for all individual partners. NEST is a platform where new ideas are openly discussed and new partnerships evolve.

The final proof will be made once NEST becomes a flagship for innovative ideas in the construction sector and more and more products are introduced into the market which were realized for the first time in NEST.

## 5 ACKNOWLEDGMENTS

The realization of NEST was only possible thanks to the generous support by numerous partners. Among them the authors would like to specially acknowledge the Canton of Zurich, the Swiss Office of Energy, the City of Dübendorf, Ernst Göhner Stiftung, Holcim Schweiz, Swisscom, Flumroc, Geberit, VZug, Laufen, arwa and suissetec.

## 6 REFERENCES

- Schweizerische Gesamtenergiestatistik 2014 (2015), Swiss Federal Office of Energy
- Ruparathna, R., et.al., Improving the energy efficiency of the existing building stock: A critical review of commercial and institutional buildings, *Renewable & Sustainable Energy Reviews*, 2016, 53 : p. 1032-1045
- The TRL scale as a Research & Innovation Policy Tool, EARTO, 2014, [www.earto.eu/fileadmin/content/03\\_Publications/The\\_TRL\\_Scale\\_as\\_a\\_R\\_I\\_Policy\\_Tool\\_-\\_EARTO\\_Recommendations\\_-\\_Final.pdf](http://www.earto.eu/fileadmin/content/03_Publications/The_TRL_Scale_as_a_R_I_Policy_Tool_-_EARTO_Recommendations_-_Final.pdf)
- Pilot and demonstration projects, Swiss Office of Energy, <http://www.bfe.admin.ch/forschungsolarwaerme/02213/03492/index.html?lang=en>
- Keplinger, T. et. al., A versatile strategy for grafting polymers to wood cell walls. *Acta Biomaterialia*, 2015, 11: p. 256-263
- Erneydan, M. A., et. al., Fully biodegradable modification of wood for improvement of dimensional stability and water absorption properties by poly(e-caprolactone) grafting into the cell walls. *Green Chem.*, 2014, 16: p. 3313-3321
- Merk, V. et. al., Hybrid wood materials with magnetic anisotropy dictated by the hierarchical cell structure. *ACS Applied Materials & Interfaces*, 2014, 6 : p. 9760-9767
- Merk, V., et. al., Hybrid wood materials with improved fire retardance by bio-inspired mineralisation on the nano- and submicron level. *Green Chemistry*, 2015, 17: p. 1423-1428
- Ihssen, J. et. al., Laccase catalyzed synthesis of iodinated phenolic compounds with antifungal activity. *Plos One*, 2014, 9(3): p. e89924
- [www.hilo.arch.ethz.ch](http://www.hilo.arch.ethz.ch)







## Expanding Boundaries: Systems Thinking for the Built Environment

### WHAT SHOULD A BUILDING BE CONTROLLED FOR? ASK THE OCCUPANTS!

Z. Nagy<sup>1\*</sup>, F. Y. Yong<sup>1</sup>, A. Schlueter<sup>1</sup>

<sup>1</sup>Architecture and Building Systems, Department of Architecture,  
ETH Zurich, Switzerland

\*Corresponding author; e-mail: nagyz@ethz.ch

#### Abstract

The energy savings of buildings promised by automatic control systems are often ineffective due to occupants who may not use the features of the system to the full potential at best, or deactivate the system at worst. Therefore, systems that adapt to the occupant over time without compromising his/her comfort are needed. In this paper, we describe such an occupant centred control framework, identify potential research gaps, and demonstrate its effectiveness in a case study.

#### Keywords:

Building control; energy efficient buildings; smart buildings; user interaction

## 1 INTRODUCTION

The building sector contributes to 40% of global primary energy consumption, and to 30% of CO<sub>2</sub> emissions [1]. Therefore, buildings offer a large leverage for the mitigation of anthropogenic greenhouse gas (GHG) emissions. Typically, such sustainable approaches are known as low-energy, or (net-)zero- energy paradigms, and are comprised of a combination of sustainable material use, climate- responsive architectural design, on-site renewable energy generation, and advanced control strategies for the operation of building systems (heating, ventilation, air conditioning (HVAC), lighting and shading).

Given the fact that typical building systems have a life span of 20-30 years, the impact of its control system on the energy and emission balance is apparent, and requires to be designed with the goals of energy efficient operation. On the other hand, as humans spend 80-90% of their time indoors, providing a comfortable indoor climate (thermal comfort and indoor air quality) is also a goal of the control system. However, because the preferences of the occupant and the goals of the controller may differ, there is a potential conflict between energy efficient operation on one hand, and comfort on the other. In short, a successful controller must find a good balance between the two.

The goal of this paper is to show that there is a discrepancy between how building systems are operated and how efficiently and comfortably they could be operated if the control would focus on understanding the needs of the occupant, rather than solely focus on technological presumptions. We thus present a new paradigm for the design of building system controls that takes the perspective of the occupant. We argue that occupant centred approaches are the most promising, if not the only approach to achieve both, occupant comfort and energy efficient operation. We demonstrate the effectiveness of the approach using results from our ongoing research.

The paper is organized as follows. The next Section gives a non-exhaustive overview of the state of the art in building control and occupant control research, and highlights the needs for an occupant centric control (OCC) approach. Then, Section 3 discusses the proposed OCC framework. Finally, Section 4 shows results from a case study, and Section 5 concludes the paper.

## 2 BACKGROUND

### 2.1 Building Control

Building control and automation considers the control of recurring equipment activities. Typical examples are maintaining the set points for HVAC systems, lighting, appliances, and security

systems. The objectives of building automation are minimization of energy consumption, improved occupant comfort, and minimization of operational and maintenance costs. The building automation industry is mature with a few key global players (Siemens, Johnson Controls, Honeywell).

In recent years, results from the control and automation and computer science communities have been applied to buildings. It is beyond the scope of this paper to provide a thorough literature review. The interested reader is referred to [2, 3, 4] for comprehensive reviews. A possible classification is provided in [2]. We use a simplified scheme in the following to classify the current trends in three major fields, classical control, modern control and soft control.

#### *Classic control*

Classical control is comprised of two-point (or on/off) controllers and the Proportional-Integral-Derivative (PID) controllers. The on/off controllers are provided with a lower and an upper set-point, where the equipment is switched on/off. It is the simplest and most intuitive controller. They are suitable for systems with small inertias, and have conversely difficulties controlling processes with large time lags [5].

The PID controller is the most widely used in industry. It acts by modulating the control signal based on the error between the current process value and its set-point. Despite their wide application, tuning the parameters/gains of the controller has to be done empirically, which may be time consuming, or even impossible [5].

#### *Modern control*

Modern control or hard control has been developed in the control systems community as a reaction to the shortcomings of the PID approach. These control approaches are based on rigorous mathematical models, and allow to define, e.g., error bounds on the controller performance (robust control), or minimize a cost function (optimal control). [2]

Amongst these controllers, model predictive control (MPC) combines robust and optimal control [29], and has also been investigated for application in buildings [6]. In the building context, MPC uses both a thermal model of the building and weather forecast to predict the future states of the building over a certain time period, and to generate a control signal for disturbance rejection and constraint handling during this period. It is possible to include occupant models to study their influence on the controller performance [7, 8]. However, the optimal control signal computed by MPC comes at the expense of high computational efforts. Furthermore, the performance of MPC is linked by its nature to the quality of the underlying model. Thus, high initial engineering costs are needed to identify a model

structure, its parameters and perform a validation, before the MPC can be applied. While tendencies exist to reduce these efforts [9], MPCs are rarely used in industrial building control applications.

#### *Soft control*

Soft control also termed intelligent control uses approaches from the computer science community combining the areas of machine learning, pervasive computing and ambient intelligence [10], initiated by the seminal work of Weiser [11]. Examples include artificial neural networks (ANNs) [12] or fuzzy logic (FL) approaches [4]. ANNs are black-box models trained on a set of available input-output data, from which a non-linear relationship can be determined and then used in control. FL controllers aim to bridge the gap between human language description defined in fuzzy sets for variables, such as temperature (e.g., hot, cold, mild, etc.), and machine instructions with if-then-else logic.

One of the successful examples so far for this approach is Mozer's ACHE house, which adapts to the preferences of its single inhabitant and reduces energy consumption by means of an ANN and reinforcement learning [13].

## **2.2 Occupant Behaviour and Comfort**

There is a large amount of research studying the conditions in which humans feel comfortable [14].

From adaptive thermal comfort research, it is understood that humans have a large tolerance for comfort, as long as adaptive measures are available [15]. For example, a study based on three databases on occupant satisfaction found that spaces that are air-temperature controlled in a narrow temperature gap (class A) are not more comfortable than those with a larger temperature gap (Class B and C) [16]. The study concludes then that tightly air-controlled buildings are not desirable given their higher energy costs for both design and operation. Rather, the temperature set-points should be based on real-time empirical feedback about their occupant's requirements. In fact, it is suggested that this occupant feedback capability should be incorporated in normal building control and operation.

A comprehensive review of the scientific literature on occupant behaviour (such as window opening, blind adjustment, thermostat adjustment, and lighting switching) although it may seem stochastic at first, « occupants undertake control actions consciously and consistently » [14].

In conclusion, occupant behaviour and interaction with building systems exhibit patterns, which are characteristic to the user and his comfort situation. Therefore, any building control approach whose goal it is to maintain the comfort of the occupant must include this information in its operational algorithm.

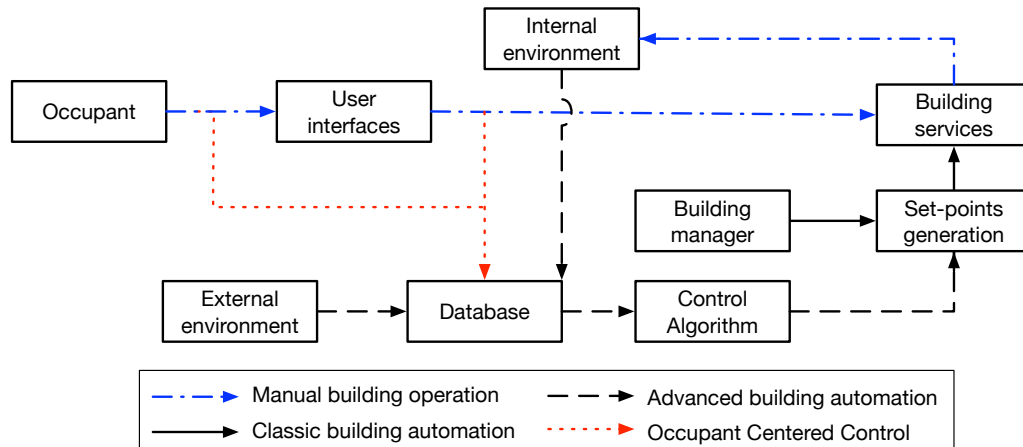

Fig. 1: The Occupant Centered Control framework.

### 3 OCCUPANT CENTERED CONTROL

In this section, we develop the occupant centred control (OCC) framework. It is illustrated in Figure 1. In a building without any automation, only the manual operation of the building systems exists. The first level of automation is with classic controllers, whereby the set-points for lighting, temperature, etc., are pre-defined by the building manager. This is often done based on experience, without any relation to interior and exterior conditions.

A level higher in complexity are the modern controllers, such as MPC. These use internal, and external environmental conditions additionally, and make a forecast in order to determine the optimal control actions. The set-points are still determined by the building managers.

In the OCC framework, however, it is recognized that the data that can be recorded from either observing the user, or capturing his interactions with the building systems, can be used to infer set-points. This in turn allows to tailor the control actions such that user comfort is truly achieved.

As a consequence, the ability to gather data and determine patterns are key requirements for the success of OCC. Therefore research should focus on (see also [17]):

- (i) Scalable, low-cost and low-power hardware for sensing, actuation and communication. This will allow for a dense sensor network to gather data.
- (ii) Algorithms for efficient pattern detection and knowledge discovery of both regular user behaviour, but also override actions.
- (iii) Methods to derive useful knowledge from these patterns, e.g., set-points, occupancy schedules, etc.
- (iv) Holistically integrate these tools into building management system (BMS), such that OCC can be applied to real buildings with little operative overhead.

### 4 CASE STUDY

Our case study focuses on lighting control in the offices of the author's research group. The details can be found in [18]. In brief, the setup in each of the investigated offices allows us to log

- The illuminance level (minute-by-minute)
- Every trigger of the occupancy sensor (PIR)
- Every action on the manual light switch
- The on/off status of the lights (minute-by-minute)

With this setup, two set-points can be determined. First, the lighting set-point for the switch-on action for the controller is determined by analysing the illuminance levels right before the occupant switch the lights on. Of course, many possibilities exist to derive the set-point. We chose to analyse the data of the past four weeks and use the minimum of the mean and the median value. Second, the time delay (TD) to switch the lights off is calculated by analysing the probability distribution of the motion sensor data, again over the past four weeks. The result is a set of user and time adaptive set-points in each office.

In addition to this automatic set-point derivation, a web interface has been designed in which the user has the ability to both to specify a set-point directly, as well as to operate the lights. This increases the adaptive measures available to the user.

We conducted two experiments. In the first one, we demonstrated the user-adaptive set-points as well as the ability of the system to save energy. For this, the system operated each day randomly in three modes, the manual mode for reference and benchmark, a comfort mode M1, and a savings mode M2. The difference between the last two is that the time delay to switch the lights off is shorter in the savings mode than in the comfort mode. The system operated double-blind, i.e., neither the occupants nor the experimenters were aware of the current mode of

the system. This was revealed only at the end of the experiment.

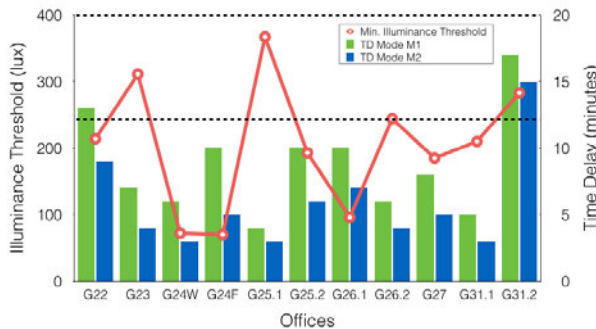

Fig. 2: Results of the first experiment : adaptive set-points.

The results, i.e., the set-points at the end of the experiment are shown in Figure 2. It is clear that each office has converged to individual settings. Furthermore, both the lighting set-point as well as the time delay are well below the generally recommended (and manually set) thresholds. As a result, the OCC method adapted to the occupant, and still reduced the energy consumption. Overall, the savings mode M2 achieved energy savings of 37.9% compared to the manual benchmark, and 73.2% compared to a worst-case scenario (all day lights on). For mode M1, the savings were 23.2%, and 66.8%, respectively.

In the second experiment, the focus was on user satisfaction and acceptance. Therefore, the experiment was conducted in two phases of 6-weeks each in the same mode, first the manual mode, then the comfort mode. Before and after each phase, the occupants were asked to fill out a questionnaire related to general lighting comfort and the satisfaction with the control system. We could conclude that

- comfort of the occupant was not adversely impacted by the OCC method.
- over 85% of the *control-on* actions and 75% of the *control-off* actions of the system were not overridden by the occupants, demonstrating high acceptance of OCC

We then charted the answers related to successful adaptation of the system as well as general satisfaction of the occupant versus the importance of lighting control for the individual occupant. The results are shown in Figure 3. It can be seen that users who were less satisfied, and found that the control system did not adapt to their needs, are the same who deemed automatic control to be of little importance (bottom-left quadrants). Furthermore, a general worst-case scenario, where users deem control highly important yet it fails adapting or leads to dissatisfaction, was avoided since only one person falls into this category.

Overall, in this view, the satisfaction with the control system appears positive. Nonetheless, more appropriate metrics and methods than questionnaires to evaluate control satisfaction are necessary.

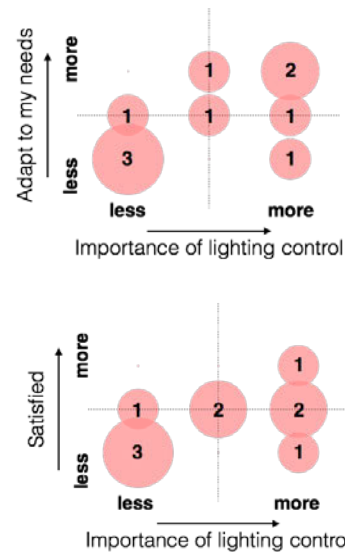

Fig. 3: User answers on adaptation, satisfaction with respect to the importance of lighting control (the numbers indicate the number of respondents).

## 5 CONCLUSIONS

In this paper we presented the occupant centred control (OCC) framework for the building context. We argued that it is necessarily the only conceivable approach if occupant comfort and satisfaction should be considered as much as possible. We have identified the research gaps for OCC. Finally, we have presented a case study with a first implementation of the OCC framework for lighting control. We have demonstrated adaptive set-points as well as user satisfaction. A potential drawback of the OCC framework is the necessary data management, and related topics such as data security and access. On the other hand, OCC holds the potential to provide individual comfort while reducing the energy consumption of buildings.

## 6 REFERENCES

1. O. Lucon and D. Üрге-Vorsatz. Fifth Assessment Report, Mitigation of Climate Change. Intergovernmental Panel on Climate Change, pages 674–738, 2014.
2. A. Afram and F. Janabi-Sharifi. Theory and applications of HVAC control systems - A review of model predictive control (MPC). *Building and Environment*, 72:343–355, 2014.
3. D. J. Cook and S. K. Das. How smart are our environments? An updated look at the state

- of the art. *Pervasive and Mobile Computing*, 3(2):53–73, 2007.
4. A. I. Dounis and C. Caraiascos. Advanced control systems engineering for energy and comfort management in a building environment-A review. *Renewable and Sustainable Energy Reviews*, 13(6-7):1246–1261, 2009.
  5. C. Dorf, Richard and H. Bishop, Robert. *Modern Control Systems* (10th edition). Prentice Hall, 2004.
  6. J. B. Rawlings and D. Q. Mayne. *Model Predictive Control : Theory and Design*. Nob Hill Publishing, LLC, Madison, WI, 5th edition, 2015.
  7. F. Oldewurtel, D. Sturzenegger, and M. Morari. Importance of occupancy information for building climate control. *Applied Energy*, 101:521–532, 2013.
  8. H. B. Gunay, W. O'Brien, I. Beausoleil-Morrison, and B. Huchuk. On adaptive occupant-learning window blind and lighting controls. *Building Research & Information*, 42(6):739–756, 2014.
  9. M. Gruber, A. Trüschel, and J.-O. Dalenbäck. Energy efficient climate control in office buildings without giving up implementability. *Applied Energy*, 154:934–943, 2015.
  10. D. Cook and S. Das. *Smart Environments*, volume 43. John Wiley & Sons, Inc., Hoboken, NJ, USA, 2004.
  11. M. Weiser. The Computer for the 21st Century. *Scientific American*, 265(3):94–104, 1991.
  12. R. Kumar, R. Aggarwal, and J. Sharma. Energy analysis of a building using artificial neural network: A review. *Energy and Buildings*, 65:352–358, 2013.
  13. M. C. Mozer. Lessons from an Adaptive Home. *Smart Environments*, pages 271–294, 2005.
  14. H. B. Gunay, W. O'Brien, and I. Beausoleil-Morrison. A critical review of observation studies, modeling, and simulation of adaptive occupant behaviors in offices. *Building and Environment*, 70(0):31–47, 2013.
  15. F. Nicol, M. Humphreys, and S. Roaf. (2012). *Adaptive thermal comfort: principles and practice*, Routledge, 2012
  16. E. Arens, M. Humphreys, R. de Dear, and H. Zhang. Are 'class A' temperature requirements realistic or desirable? *Building and Environment*, 45(1):4–10, 2010.
  17. A. De Paola, M. Ortolani, G. Lo Re, G. Anastasi, and S. K. Das. Intelligent Management Systems for Energy Efficiency in Buildings. *ACM Computing Surveys*, 47(1):1–38, 2014.
  18. Z. Nagy, F. Y. Yong, M. Frei, A. Schlueter, Occupant Centered Lighting Control for Comfort and Energy Efficient Building Operation, *Energy and Buildings*, 94,100–108, 2015





## Expanding Boundaries: Systems Thinking for the Built Environment

### PREDICTION OF USERS' BEHAVIOUR PATTERNS IMPACT ON ENERGY PERFORMANCE OF A SOCIAL HOUSING IN CREMONA, ITALY

L.C. Tagliabue<sup>1\*</sup>, M. Manfren<sup>2</sup>, A.L.C. Ciribini<sup>1</sup>, E. De Angelis<sup>3</sup>

<sup>1</sup> University of Brescia, Department DICATAM, Via Branze 43, 25123 Brescia, Italy

<sup>2</sup> University of Bologna, Department of Industrial Engineering (DIN), Viale del Risorgimento 2, 40136, Bologna, Italy

<sup>3</sup> Politecnico di Milano, Architecture, Built environment and Construction Engineering Department, Via Ponzio 31, 20133 Milano, Italy

\*Corresponding author; e-mail: chiara.tagliabue@polimi.it

#### Abstract

Social housing is a crucial challenge of European cities, facing the pressing need to provide accommodation for an increasing and changing population with new family models. Functionality, adaptability and quality of living are fundamental topics in social housing. Economic constraints concur to shape the size of apartments and construction choices in the design phase. Further, energy efficiency is a key factor for long-term economic sustainability by reducing running cost in the operation phase. The availability of calibrated energy models is fundamental to perform effective energy management during building lifespan and the ability to investigate users' behaviour by means of physical-statistical models is fundamental to improve current design and operation practices.

The case study presented is a social housing located in Cremona, Italy, built by a Social Fund engaged in retrofit interventions on existing social housing and new construction. The variability of energy use, resulting from different occupancy, appliances, ventilation patterns and comfort settings has been investigated by means of simulations. Behavioural patterns are inherently dependent on age, number of components of the family, comfort preferences and activities (i.e. appliances and lighting use). Further, possible occupants' aggregations are constrained by size and flexibility of the architectural layout of residential units (e.g. number of users, change in ability due to ageing, etc.). The results are presented in a graphical way (i.e. energy demand vs outdoor temperature), enabling statistical correlation among energy demand and physical parameters assumed in different simulation scenarios, which can be used for model calibration in the operation phase (for energy management purposes). The results show the large variability of energy performance in different scenarios and the large difference with respect to standard assumptions, highlighting the benefits of parametric behavioural simulation to obtain realistic data for techno-economic assessments.

#### Keywords:

Social housing; behavioural pattern; energy performance; users' behaviour

## 1 INTRODUCTION

Social housing has a strategic role in the European residential sector. The European Committee for the promotion of the right to housing (CECODHAS) defines social housing as *housing solutions for those families whose needs cannot be met with market conditions and for whom assignment rules are established* [1].

In the European countries a variable percentage ranging from 30% to about 10% of the new construction is ascribed to social rented housing [2]. Refurbishment of social housing is a widely investigated field due to the large potential energy saving in the aging residential buildings stock in Europe [3,4]. Envelope redesign and renewable energy technologies are the main issues [5]

because the construction period of the building stock ranges from 1920 and 1970 in most cases. Further, the new social housing is an experimental ground in which the Municipalities/Committee are interested in promoting energy efficiency [6,7] checking the evidence of cost-optimality criteria of the technological solutions adopted [8-11] and endorsing social upgrading. The new social housing design, as the case study used in this paper (Fig.1), is aligned with the best practices in energy efficiency [12].



Fig. 1: Aerial view of the social housing in Cremona, Italy.

Moreover, the performance gap that can be found in comparing the designed performance and the actual performance of the buildings is another interesting field. Probabilistic design and behavioural pattern analysis [13] can be employed to explore the uncertainty and variability of performance already in the design phase. The paper deals with occupants' behaviour variability in residential buildings and their influence on energy consumption. The new families, the new culture of living in the multi-ethnic society and the need of temporary housing solutions introduce new important topics to be considered in design optimization. The potential flexibility and re-configuration of the spaces during the building lifespan for the evolving families and the aging population (e.g. adaptation of spaces for disability) add additional complexity to the project. In order to provide meaningful techno-economic evaluations, parametric and probabilistic design techniques can be adopted [14,15].

## 2 CASE STUDY

### 2.1 Social Housing in Cremona

The case study described in the paper is a social housing settlement in Cremona (Italy) realized to achieve energy efficiency and flexibility for users. The settlement has a C shape with three main blocks with the major axis east-west and a block with the major axis south-north (Fig. 2).

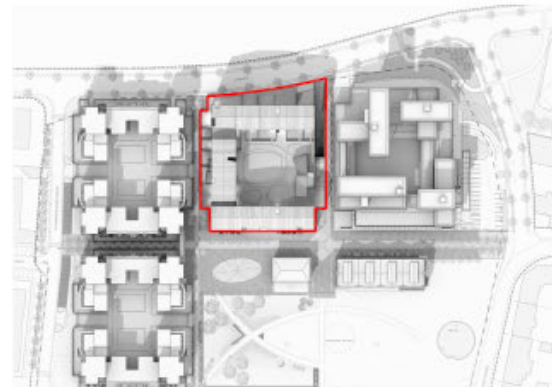

Fig. 2: Layout of the Social Housing settlement in Cremona, Italy.



Fig. 3: View of the south façade of the building.

The south and west blocks have respectively six and five floors, while the north block has four floors (Fig.3,4).



Fig. 4: View of the east and north facades of the buildings in the courtyard.

### 2.2 Typical floor configuration

The apartments' sizes range from about 45 to 90 m<sup>2</sup> and the spaces can be used by different family groups, according to the standard prescribed by legislation. A typical floor with apartments of different sizes has been considered (Fig. 5) to analyse the impact of the variability of occupancy patterns on energy consumptions.



Social housing has to be adaptable to changing users and aggregation of people, considering also possible scenarios in which a temporary accommodation takes place. The typical floor is composed of five apartments:

- n. 2 apartments are sized for families.
- n. 2 apartments can be used by couples or small families.
- n. 1 apartment is sized for a single user.

A percentage of about 20% of the apartments is considered as unoccupied due to change in occupants' range and temporary use (assumed as apartment used only during the weekend). The smallest apartment facing north can be considered as a temporary location for people in transition.

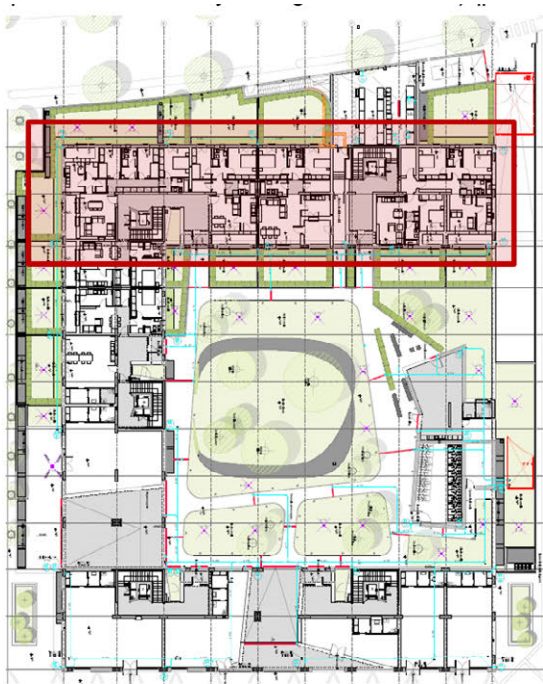

Fig.5: Detailed plan of the apartments and typical section of the floor (red).

In table 1 the sizes of the apartments, the location (South, North, West, East) and orientation of the windows (single, double, triple oriented), with the average possible number of users are listed. In the apartments, it could be possible to accommodate more users (e.g. +1) in a temporary use scenario; however, the analysis in this phase is oriented to model the different behaviour of typical families and couples. A denser and more intense use and space configuration will be examined in depth in further phases of the study and calibration of the models will be performed with measured energy consumption data.

In table 1 the users are defined as standard number (S.), related to the apartment area and people density for residential use (0.04 person/m<sup>2</sup>) and assumed (A.) used to define a family (evolving over time).

Name	Size [m <sup>2</sup> ]	Side	Orient.	Users	
				S.	A.
A1	86.9	E	S,E,N	3.48	
A2	83.9	W	S,N	3.36	
A3	53.7	SE	S	2.15	
A4	53.7	SW	S	2.15	
A5	46.1	N	N	1.84	

Table 1: Typical composition of apartments in the floor of a building block.

Nevertheless, the number of users is not sufficient to explore the variability of occupancy patterns; age and related behavioural components are key factors in energy consumption, as shown and discussed in section 3.

### 3 RESEARCH METHODOLOGY

The social housing case study has been used to simulate different configurations of the mixed use, evaluating the incidence of typical families' behaviour on the thermal energy consumption of the building. The data related to surface and users of the apartments have been combined, introducing the behavioural variability in simulation input data, as described in section 3.1. The calculation method to estimate the energy performance for single apartments and for the whole building is described in section 3.2, whereas the results are reported in section 4 and discussed in section 5.

#### 3.1 Behavioural patterns

The social housing settlement in Cremona has been constructed following recent energy efficiency standards, with a high performance envelope. The variability of energy use, resulting from different occupancy, appliances, ventilation patterns and comfort settings, is dependent on age, number of components of the family, comfort preferences and activities (appliances and lighting use). The users listed in table 1 have different behaviours and impacts with respect to the standard values used for internal gains, ventilation rates and indoor set-point temperatures for residential buildings (i.e. 4 W/m<sup>2</sup> internal gains, 0.3 air changes per hour, 20/26°C winter and summer set points). Therefore, standard values have been adjusted with multipliers to introduce the behavioural variability due to age, family composition and temporary use (Fig. 4,5,6). The operating schedules used in simulation are defined for:

- Unoccupied apartment (randomly changing)
- Couple with sons (teenagers) (A1)
- Couple with kids (children) (A2)

- Young couple (A3)
- Aged couple (A4)
- Single temporary use (A5)

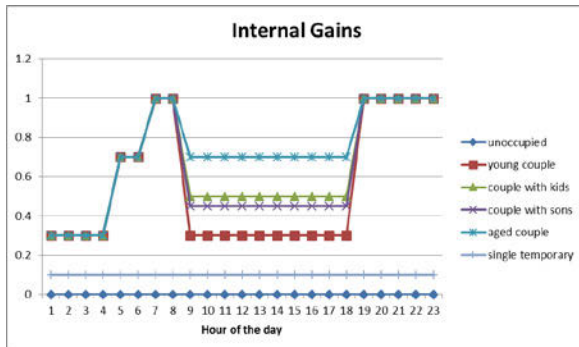

Fig. 4: Internal gains schedules.

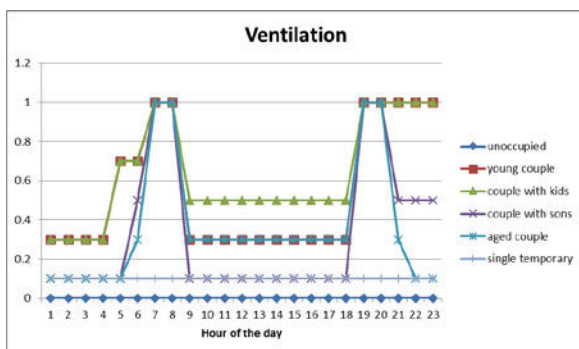

Fig. 5: Air change rate schedules.

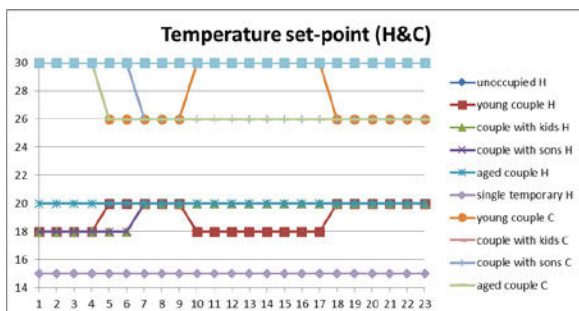

Fig. 6: Temperature set-point profiles.

### 3.2 Parametric energy simulation

The analysis of the behavioural pattern incidence has been carried out through parametric dynamic energy simulations [16]. The models have been simulated using variable occupancy profile patterns and related energy demand for appliances and lighting. First, the standard occupancy profile for residential buildings is applied to all the apartments. After that, it is compared to the variable patterns simulated parametrically. The mixed distribution has been further varied, changing the occupancy of the apartments, i.e. simulating a variability in tenants' presence in the building (occupied/unoccupied). Results are given as specific energy demand for heating and cooling to show the variability resulting from occupancy patterns. Results for the different apartments (A1-A5) are reported to check out the behavioural incidence, however the north

facing single apartment has an unfavourable orientation affecting the energy performance.

## 4 RESULTS

The analysis shows the standard occupancy profile as daily energy demand for the building compared to custom behavioural occupancy profile during winter season (heating) and summer season (cooling). The standard profile for residential building considers a 24h occupancy with the people density reported in table 1 and data as described in section 3.1. The custom behavioural profile uses the data scheduled in fig.4-6 forecasting the full occupancy of all the apartments by the described families.

### 4.1 Standard profile vs custom profile

By comparing the heating demand (Fig.7) it is possible to verify how the standard profile underestimates the energy demand.

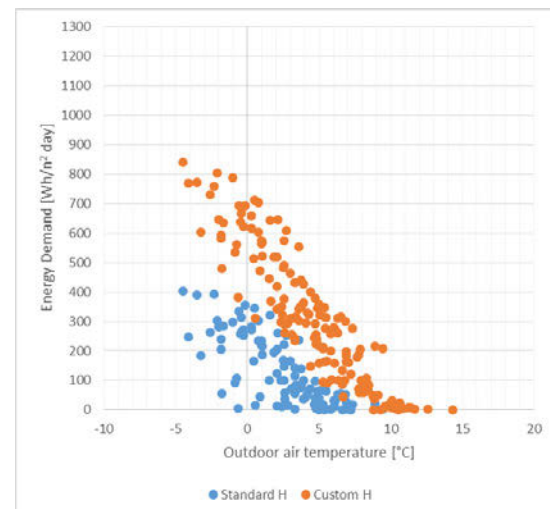

Fig. 7: Heating demand with standard occupancy profile and custom behavioural pattern.

Considering the cooling demand (Fig. 8) the standard profile shows a higher consumption with respect to custom profiles, due to variability of set-point temperature and occupancy.

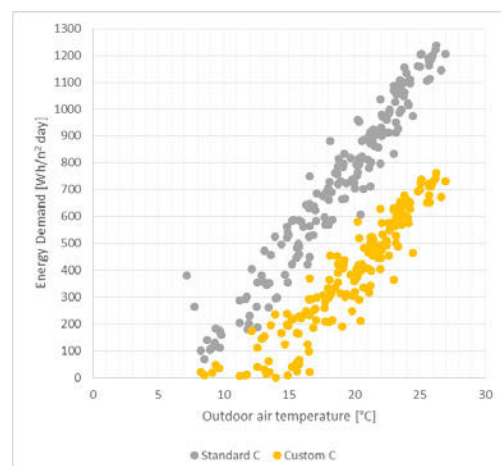

Fig. 8: Cooling demand with standard occupancy profile and custom behavioural pattern.

The variability introduced by the families' use is shown in the following section.

#### 4.2 Behavioural occupancy patterns

The behavioural patterns are constructed by interpreting the behaviour of groups of people considering the occupancy of the house's spaces, the use of equipment, the needs for ventilation and the variable set-point adopted during the day in winter and summer. The energy demand is not sharply divided for families, however, it is possible to recognize different distributions and trends: more people/more occupancy hours determine higher demand in winter (Fig. 9) while in summer more tolerance in changing temperature/favourable exposition/less occupancy hours define reduced cooling demand (Fig. 10).

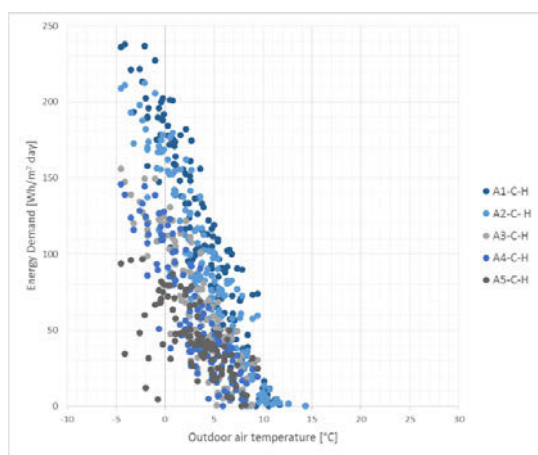

Fig. 9: Heating demand for behavioural patterns in the different apartments.

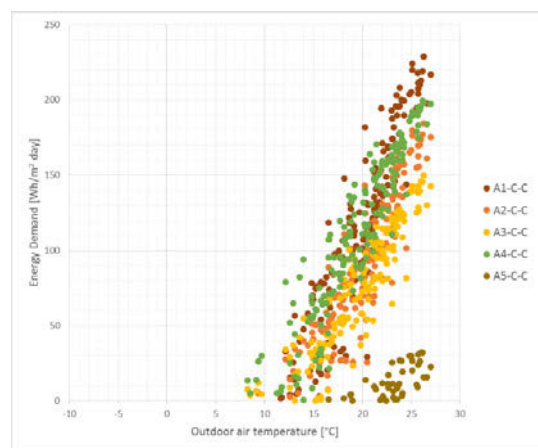

Fig. 10: Cooling demand for behavioural patterns in the different apartments.

## 5 DISCUSSION

### 5.1 Variability in occupancy

A specific issue is the occupancy of the apartments by tenants that varies significantly in time, affecting the energy demand of the building. For this reason, the analysis reported shows the variability of energy demand when an apartment is randomly considered empty (Fig. 11).

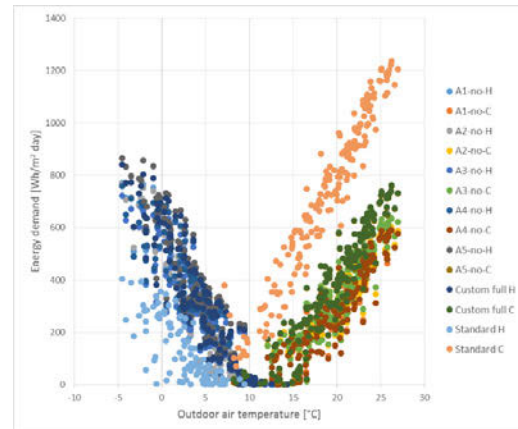

Fig. 11: Heating and demand with standard occupancy profiles and custom behavioural patterns.

The building is realized to comply with present energy efficiency legislation and its thermal energy demand (calculated in standard conditions) for winter is very low: 13.34 kWh/m<sup>2</sup> year. The energy demand, considering more realistic scenarios, results to be more than double, however, always no more than 51 kWh/m<sup>2</sup> year. In summer, the standard calculation largely overestimates the energy demand while in the realistic scenarios it is always lower than 63 kWh/m<sup>2</sup> year. The variability of occupancy (tenants) can lead to a maximum variation of 12% for heating and 27% for cooling for the custom (non-standard) simulation profiles considered (Fig. 12).

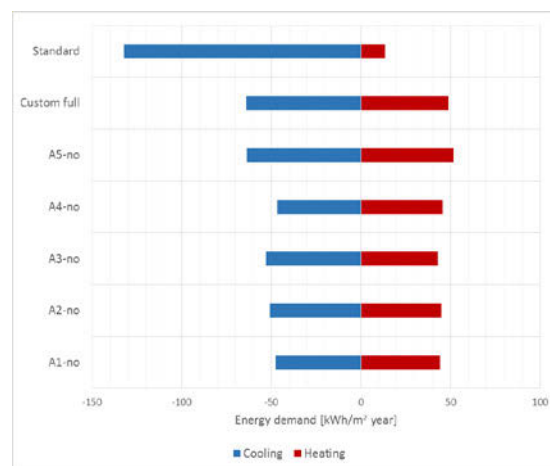

Fig. 12: Heating and cooling demand with standard occupancy profile and custom behavioural patterns and occupancy.

## 6 CONCLUSIONS

Behavioural occupancy patterns simulation is used to show the high variability in energy performance determined by end-users. The results highlight the limitation of simulations using standard profiles, without a parametric analysis. The variability in terms of energy performance is relevant and the difference encountered among

parametric scenarios is up to 27% in the selected case studies. A much larger difference is the one encountered with respect to the standard profile which causes an overestimation of cooling and an underestimation of heating demand.

## 7 REFERENCES

1. CECODHAS, European Social Housing Observatory, Social Housing in the EU: Time for legal certainty for local authorities, social housing providers and millions of European households, Report to the European Commission, Brussels, March 2005.
2. Baldini M., Federici M., Il Social Housing in Europa, Centro di Analisi delle politiche pubbliche, CAPPaper n. 49, November 2008.
3. Concerto/SESAC, Innovative sustainable construction: Together for the low-energy city with a high quality of life, 2011, <http://www.concerto-sesac.eu/>
4. Fondazione Housing Sociale, A foundation for social housing in Italy, Presentation Report 2012.
5. Pennestri D., The energy requalification of social housing in the Italian and Dutch contexts, *TECHNE- Journal of Technology for Architecture and Environment*, 2012, n.4, pp.298-305.
6. Directive 2010/31/EU of the European Parliament and of The Council of 19 May 2010 on the energy performance of buildings (recast), Official Journal of the European Union 18.6.2010.
7. EN 15603, "Energy performance of buildings — Overall energy use and definition of energy ratings", 2008.
8. European Commission, Energy Directorate General, Meeting Document for the Expert Workshop on the Comparative Methodology for Cost Optimal Minimum Energy Performance Requirements, In preparation for a Delegated Act in Accordance with Art 290 TFEU 6 May 2011 Brussels.
9. Corgnati S.P., Fabrizio E., Filippi M., Monetti V., Reference buildings for cost optimal analysis: Method of definition and application, *Applied Energy*, 102 (2013) 983-993.
10. Kurnitski J., Saari A., Kalamees T., Vuolle M., Niemelä J., Tark T., Cost optimal and nearly zero (nZEB) energy performance calculations for residential buildings with REHVA definition for nZEB national implementation, *Energy and Buildings*, 43 (2011) 3279-3288
11. EN 15459, "Economic evaluation procedure for energy system into buildings", 2008.
12. Tagliabue L.C., Buzzetti M., Manfren M., Social Housing retrofit towards energy efficiency thresholds extensible on public housing in Italy, *Clean Electrical Power (ICCEP)*, 2013 International Conference on, 717-723.
13. Tagliabue L.C., Manfren M., De Angelis E., Ciribini A.L.C., Energy Efficiency Assessment Based on Realistic Occupancy Patterns Obtained through Stochastic Simulation in Modelling Behaviour: Design Modelling Symposium 2015, edited by Mette Ramsgaard Thomsen, Martin Tamke, Christoph Gengnagel, Billie Faircloth, Fabian Scheurer, Springer, 2015, ISBN 978-3-319-24206-4.
14. Widén J., Molin A., Ellegård K., Models of domestic occupancy, activities and energy use based on time-use data: deterministic and stochastic approaches with application to various building-related simulations. *Journal of Building Performance Simulation* 5, 2011, 27-44.
15. Parys W., Souyri B., Woloszyn M., Agent-based behavioural models for residential buildings in dynamic building simulation: state-of-art and integrated model assembly, IBPSA Conference, Arras, France 20th -21<sup>st</sup> May 2014.
16. Crawley D.B., Hand J.W., Kummert M., Griffith B.T., Contrasting the capabilities of building energy performance simulation programs, *Building and Environment*, 43 (2008) 661-67



## Expanding Boundaries: Systems Thinking for the Built Environment

### TOWARDS SUSTAINABLE OCCUPANT BEHAVIOUR AND ORGANIZATIONAL CHANGE

D.V. Keyson<sup>1\*</sup>, T.J. Jaskiewicz<sup>2</sup>

<sup>1</sup>Delft University of Technology, The Netherlands

<sup>2</sup>Delft University of Technology, The Netherlands

\* Corresponding author; d.v.keyson@tudelft.nl

#### Abstract

Moving office organizations and staff culture towards sustainable practices requires a multifaceted and integral approach. In this paper a model with four focal areas for influencing practices is presented. The focal areas are: (i) bottom-up interventions aimed at promoting the adoption of sustainable practices through co-design, (ii) exploring new opportunities for awareness generation, by providing user centric tools and reflective interfaces, (iii) up-scaling, with a focus on how to transform group level changes in practices across the organization, (iv) top-down, which implies creating policy and recognition to promote sustainable practices. The four focal areas have been derived from a series of ongoing pilot studies in the field using co-design methods.

#### Keywords:

Sustainability; office; prototyping; co-design; practices; behaviour; energy; comfort

## 1 INTRODUCTION

The aim of this paper is to describe a method of practice change in the office workplace, with the goal of reducing energy consumption while enhancing occupant comfort. Whereas facility managers may have the technical means to reduce energy use, occupant practices and social, organizational and technical constraints may limit the ability and motivation to change. Energy feedback and comfort insights for occupants and facility managers are often lacking. The facility manager is often situated remotely and not involved in monitoring comfort and energy consumption for given spaces in the building. Furthermore, buildings, management, and raising expectations lead many occupants dissatisfied with the indoor environment [1],

Influencing office practices in terms of sustainability is a complex problem and thus requires an integral approach. The approach taken is based on co-design [4] and in-field methods. In moving organizations and staff culture towards sustainability, there are a number of potential obstacles to change and many players in the loop. For example:

- Office occupant energy consumption awareness: office staff is typically

unaware of actual energy cost, and may assume that it's not their problem. Little or no information on the quality of the office environment is readily available to office occupants, and occupants may lack the knowledge, skills and motivation to reduce energy use and improve their work environments.

- Building management systems: from a technology perspective often do not achieve the desired result in terms of providing occupant comfort. In a study by Moezzi et al. [1], approximately 61% of office workers were found to be unsatisfied with the indoor climate.
- Facility management: typically building facility operators or managers in larger buildings are "hidden away" and have limited interaction and communication channels with office staff [1].
- Policy: the focus on building certification schemes for sustainability, such as LEEDS and BREEAM, are based on building technology, rather than monitoring and assessing occupant behaviour.

- Corporate management: may think of sustainability as a matter of reporting on 'the way we do business,' while lacking a clear understanding of how to embed sustainability in day-to-day practices [1].

## 2 A MULTIFACETED APPROACH

The presented approach is based on three ongoing pilot tests in a range of organisations. The first pilot location is a large institute consisting of nine buildings on a campus with staff from across Europe, the second place is a flexible work environment with highly mobile consulting staff situated in a high-rise building, and the third site comprises a formal and hierarchically structured building management firm with clear staff roles.

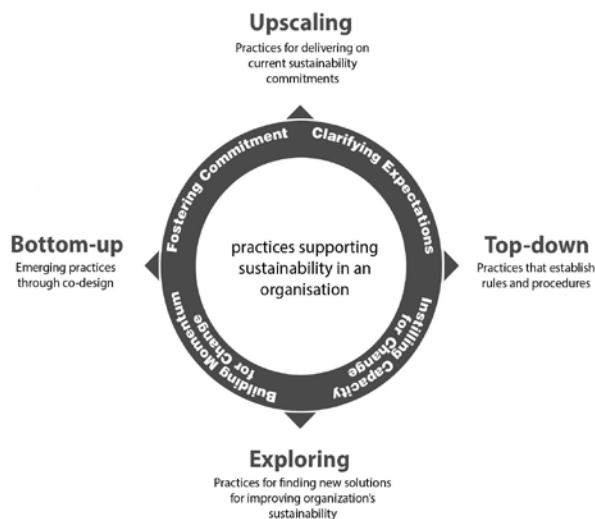

Fig. 1: Model of four focal areas for fostering sustainability in organizations.

When considering different angles in influencing sustainable practices in the organizations studied, four focal areas were identified. The four areas for targeting sustainable change are shown in Figure 1, being Up-scaling, Bottom-up, Exploring, and Top-down. Each of the areas and the corresponding strategies for changing practices are described below. The organizational model was inspired by the framework of the Network for Business Sustainability [2].

## 3 PILOT APPROACH

The ongoing pilots follow an intervention approach based on an iterative cycle involving context research, solution identification and user testing. This approach was developed during the SusLab project ([www.suslab.eu](http://www.suslab.eu)). As detailed below, a modular prototyping platform [5] supports co-design with users, with self-reporting tools, indoor climate sensors, and customizable feedback interfaces. (Figure 2).

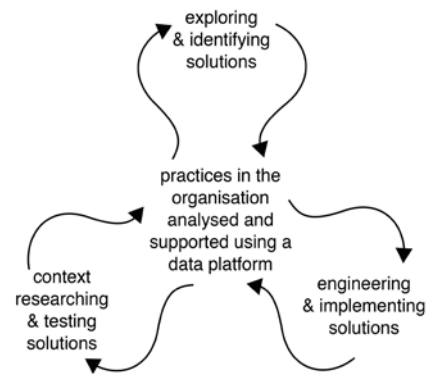

Fig. 2: The pilot intervention approach.

## 4 MULTIFACETED MODEL FOR FOCUSING PRACTICES

In the following sections each of the identified focal areas for targeting organizational change and sustainable practices are briefly described along with field observations based on the current pilots.

## 5 EXPLORING WITH OCCUPANTS

Practices focused on "Exploring with office occupants" involve:

- Stimulation of the process of awareness generation, as a prerequisite to organizational change
- Identification and involvement of lead users as change agents in the organization
- Context research to gain deeper insights into the relevant practices, while enabling occupants to reflect on their practices.

For example, ventilating a room is an activity that most occupants were found to engage in, but the way in which rooms are ventilated varies across pilot locations. Certain differences were due to the building type and HVAC installation, or having office windows that could or could not be opened. During co-creation sessions at one of the sites the participating occupants explained that ventilation for them was a social behaviour. For example, opening doors to the corridor in one of the buildings was a way for office occupants to engage in casual chats happening in the corridors, or limiting the amount of noise by closing doors when engaging in focused work. Consequently, the solution idea co-designed for more energy efficient room ventilation involved leaving the doors open, and introducing an interface signalling need for quietness around one's door, or readiness to engage in a chat.

### 5.1 Exploring: contextual enquiries

To gain insights into the participant's workplace while creating awareness in the process, contextual enquiries were conducted with the

goal of understanding the subjective perception of comfort and energy use in the workplace. Participants filled in a timeline, as shown in figure 3 below. The step included encoding observations by a researcher in-situ and post observation interview to verify the observations.

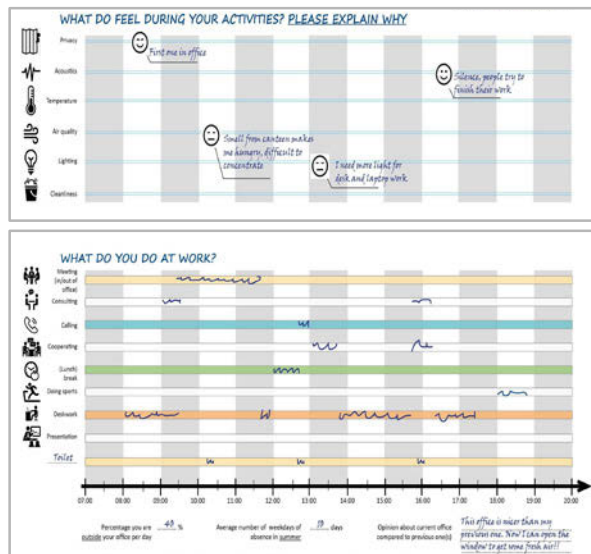

Fig. 3: An example of a timeline filled in by occupants as part the contextual enquiry.

## 5.2 Exploring: involving lead users

The involvement of lead users in the exploration phase was found to be critical to building momentum for change. Local safety and health officers or sustainability officers were helpful in identifying lead users. Many of the participants were personally motivated having felt the need to improve their indoor comfort levels or a keen desire to follow sustainable practices. Recognition and support of the lead users' role by upper management was also an important motivating factor.

## 5.3 Learning from objective data

To gain deeper insights into the actual building performance in relation to subjective experience, wireless sensor nodes were placed in a representative range of offices at each of the pilot sites to measure key indoor climate parameters such as air temperature, radiant temperature, draft, humidity, light level, sound level, movement activity and CO<sub>2</sub> concentrations. The data was then shared with the pilot participants and gaps in perceived versus actual comfort levels were identified (Figure 4). For example, at the European institute site in the Netherlands, staff from northern European countries generally felt too warm, while staff from southern Europe found the indoor climate to be too cold. In short, some staff was influenced by their past climate culture, despite being in a new location.

## 6 BOTTOM-UP

The bottom-up focal point lies at the intersection of building momentum for change and fostering commitment. It involves identifying approaches that stimulate the bottom-up engagement of building occupants towards sustainable practices. In the current pilot self-reporting tools were co-developed with the pilot participants. For example, a noise (hall-way chatter) button, air quality (smells) and mood slider was requested and implemented within one week using rapid prototyping techniques based on a modular design (Figure 5). A customizable indoor climate data feedback dashboard was also created (Figure 6).

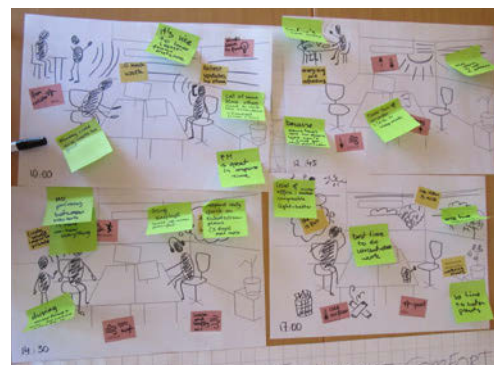

Fig. 4: A sketchy storyboard is used to explain to participants the research findings and the correlation between observed practices and measured data.

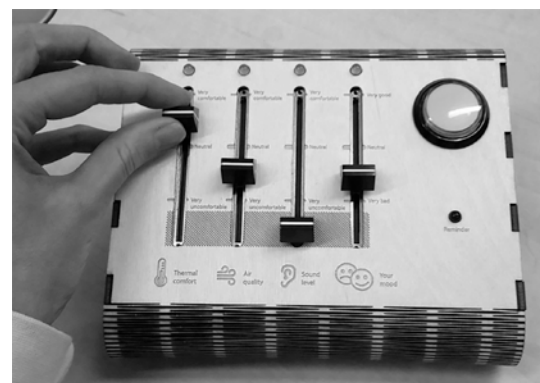

Fig. 5: Custom self-reporting tool based on co-design sessions with office occupants, built using rapid prototyping techniques.

An example of how the self-reporting tools became embedded in practices was the monthly clean-up afternoon organized by office workers to socialise with each other, remove sources of dust and organise the building wing better. The clean-up afternoon was also proposed as an opportunity to exchange reflections on energy consumption and indoor climate quality based on data collected by occupants in the preceding weeks.

### 6.1 Context research: prototyping with users

A co-design driven approach was sought in the pilot to actively engage occupants in workshops

to create tools which would assist them in reporting and reflecting on their indoor comfort and general wellbeing. The co-design workshops were focused on creating self-reporting tools that were combined with information from the networked wireless climate sensor nodes. The basic assumption here was that by actively engaging users in the co-design of their self-reporting tools, they would be more likely to adopt the resulting platform, while at the same time the system requirements could be defined.

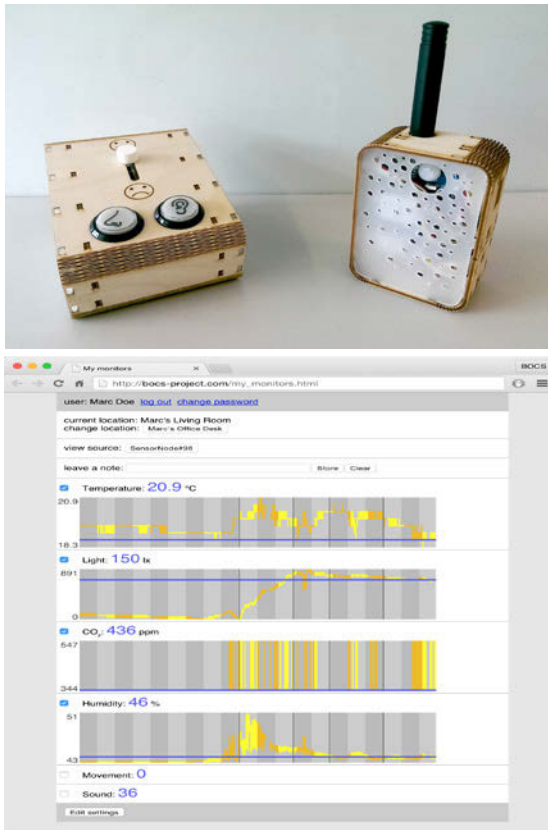

*Fig. 6: Basic self-reporting controller with flexible enclosures to accommodate different button and slider formats and a climate sensor node (top), and a personalised web interface with the indoor climate feedback display (bottom).*

In order to support the co-design process, a rapid prototyping approach was developed based on supporting rapid changes through a flexible and modular design. As in the case of sensor hardware, the self-reporting devices were developed using modular electronic components. These components in combination with rapid-prototyped enclosures permitted production of small batches of fully customized devices within several days. Turnaround time was considered key to ensure user motivation. A similar approach was adopted in designing online feedback interfaces. Each information display type was developed as a modular building block which could be combined with other information display blocks, depending on user needs articulated during co-design sessions (Figure 5).

## 7 UP-SCALING

The results from the self-reporting applications and resulting changes in practices have been shared and communicated with other groups in each of the pilots. Currently testing is underway to consider the transferability of resulting practices to groups not actively involved in the co-design workshops. In each of the pilot sites corporate communications have been active in communicating the pilot work across the organization. A front-end user interface affording rich data visualizations for perceived and measured comfort and energy consumption as part of an integral facility information system is currently under development.

## 8 TOP-DOWN

There is a clear potential for certification and recognition schemes that can stimulate organisational change and sustainable practices. The focus should be on the potential for energy savings and improved comfort, resulting in higher staff productivity and wellbeing. Along these lines, GRESB recently launched a health and wellbeing building certification module. The module is an optional supplement to the GRESB Real Estate Assessment, which is an annual survey on behalf of a large group of institutional investors that captures information regarding the environmental, social, and governance performance of property companies, fund managers and developers.

## 9 CONCLUSIONS AND NEXT STEPS

There is generally a lack of tools and methods for workplace professionals to engage office occupants in working towards improving comfort and sustainability. Classical methods such as questionnaires or elaborate and expensive indoor climate measurement devices are limited in terms of their potential impact on behaviour and organizational change. There is a wealth of opportunities in the emerging field of Sustainable Human Computer Interaction in deploying prototyping and co-design methods in the office workplace. The ongoing pilot work has demonstrated the potential of SHCI interventions to promote sustainable practices, while involving facility managers, office staff, and upper management in the process. As noted by Sliberman et al. [3], when viewing user through the lens of practice one can see in which way behaviour is constrained. SHCI needs to look beyond the individual and consider how changes in practices at the organizational level and policies can be addressed in the real world context.



## 10 ACKNOWLEDGMENTS

The authors would like to thank the Climate-KIC Building Technology Accelerator Flagship for support and Martin Havranek, Richard Bekking and Marc de Hoogh for technical support. Thanks to Jantine Doolaard who conducted field testing.

## 11 REFERENCES

1. Mithra Moezzi, Christine Hammer, John Goins, and Alan Meier. 2014. Behavioral strategies to reduce the gap between potential and actual savings in commercial buildings. Contract Number: 09-327. Sacramento: Air Resources Board.
2. Network for Business Sustainability, Embedding Sustainability in Organizational Culture. 2010.  
<http://nbs.net/wp-content/uploads/Executive-Report-Sustainability-and-Corporate-Culture.pdf>
3. M. Silberman, Lisa Nathan, Bran Knowles, Roy Bendor, Adrian Clear, Maria Håkansson, Tawanna Dillahunt, Jennifer Mankoff  
Next Steps for Sustainable HCI.pg 67-69  
SEPTEMBER–OCTOBER  
INTERACTIONS.ACM.ORG 2014  
INTERACTIONS
4. Ingrid Mulder, Pieter Jan Stappers. 2009. Co-creating in practice: results and challenges. In Collaborative Innovation: Emerging Technologies, Environments and Communities, Proceedings of the 15th International Conference on Concurrent Enterprising: ICE 2009, 22–24
5. Peter Coughlan, Jane Fulton Suri, and Katherine Canales. "Prototypes as (Design) Tools for Behavioral and Organizational Change A Design-Based Approach to Help Organizations Change Work Behaviors." *The journal of applied behavioral science*





## MODELLING LOAD PROFILES FOR THE RESIDENTIAL CONSUMPTION OF ELECTRICITY BASED ON A MILIEU-ORIENTED APPROACH

N. Haufe<sup>1\*</sup>, M. Ziegler<sup>2</sup>, T. Bednar<sup>2</sup>

<sup>1</sup> TU Wien, Department of Spatial Planning, Centre of Sociology, Karlsplatz 13, A-1040 Austria

<sup>2</sup> TU Wien - Institute of Building Construction and Technology; Research Center of Building Physics and Sound Protection, Karlsplatz 13, A-1040 Vienna, Austria

\*Corresponding author; e-mail: nadine.haufe@tuwien.ac.at

### Abstract

Residential consumption of electricity shows big variance between households. Understanding and integrating these differences into load profiles is important for forecasting residential energy consumption, to improve controllability of power grids and for the successful achievement of energy efficiency targets. This paper combines a sociological milieu based approach to the explanation of the energy consumption with the modelling of load profiles, in order to close the gap between the typical modelling of load profiles based on mean values and the actual residential consumption of electricity.

### Keywords:

Electrical Load Profiles; Social Milieus; Residential Energy Consumption

## 1 INTRODUCTION

Electrical load profiles are used to analyse the specific time of the electrical energy consumption caused by both HVAC system (Heating, Ventilation and Air-Condition) and occupancy. A load curve visualizes the use of electrical energy over time, showing watts on the y-axis and time on the x-axis. Due to simulated and predetermined controlling mechanism regarding the building operation, the time dissolved load profile for the building operation is important. This knowledge can be used for load shifting or demand and respond potentials, not to mention for a better controllable power grid. For the planning of power grids for example, not only the overall quantity of electricity consumed is of importance, it is also important to know at what time of the day the electricity will be demanded. Since the energy demand for the building operation is decreasing due to refurbishments and more efficient technologies, the part of residents-made energy demand and the analyzation resp. visualization of the use of electrical energy over time is getting more important.

One of the current problems of building planners and energy consultants is that current standards for the calculation of the energy performance of

residential houses is inappropriate to estimate the individual use of energy consumption. The modelling of household electricity demand is mostly based on mean values for the whole population (e.g. Paatero and Lund [1]). To increase the significance of predicted energy consumption, this approach results in a deviation between the estimated and actual energy consumption, by considering the inequalities of different households.

The wide variation in residential energy consumption is well known, but not well understood [2,3,4]. This paper combines a sociological approach to the explanation of the energy consumption with the modelling of load profiles, as a step to close the gap between the estimated and actual residential consumption of electricity.

## 2 UNDERSTAND ENERGY CONSUMPTION

Households exhibit extreme variability in energy consumption from one house to another. Many factors contribute to residential energy consumption resp. the electricity consumption, such as climate, the building characteristics (size, age, construction), the number and age of the occupants, and the amount and types of

electrical appliances. Goldstein and Fairey state that “the unexplained variance in home energy use, when using only (weather, home size, and number of occupants), is normally greater than 40% of the mean [4]. The variation in energy consumption regarding differences in climate and building characteristics is well studied. However, the effect of various appliances and especially the variation regarding the behaviours of people which are using them (e.g. rebound-effects), is less understood [5].

Many fields try to explain these differences from different perspectives, such as economics, psychology and sociology looking at the influence of income, norms, attitudes and values. In sociology it is assumed that it is possible to describe and explain social differences and behaviour with features of social inequality (single indicators such as income, wealth, education, professional position, ethnic origins, gender, age, household type, etc., respectively indices such as social class, social status, social milieu, etc.). In this case, research into social stratification in modern societies has shown that the complexity of social activities cannot be explained satisfactorily by sociodemographic or socioeconomic variables alone. Attitudinal and value variables resp. lifestyle- and milieu-based approaches have been introduced in order to explain and understand individual behaviour in more depth and to segment the population into meaningful (target)groups (e.g. market research) [6]. Hradil (2009) argued that life goals resp. fundamental values and everyday attitudes define the behaviour of people and presented a three stage model: social status, social milieu, and social action. Under social milieu, he understands a group of people who have the same external conditions of life and inner basic attitudes, out of which forms common field-specific lifestyles (attitudes and behaviour patterns) [7].

For the energy consumption research means that, the milieu resp. fundamental values and everyday attitudes determine the typical behaviour pattern of energy use and the observable energy relevant behaviour (Fig. 1). Socioeconomic structures are no longer primarily responsible for behaviour but remain as boundaries.

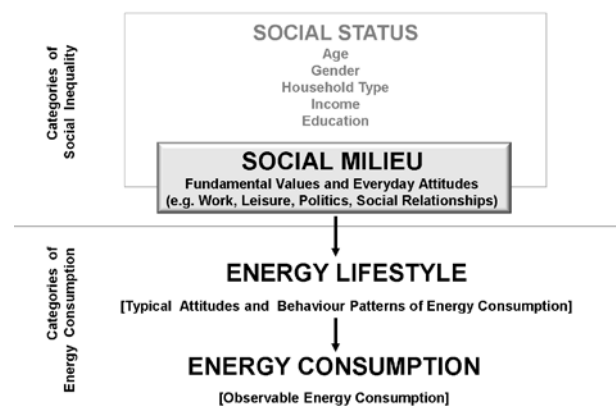

Fig. 1: Theoretical construction to explain energy consumption [6].

Based on this theoretical sociological background, this paper focused how to create electrical load profiles based on a milieu oriented approach.

### 3 DATA AND METHODS

The modelling of social differentiated load profiles based on a representative quantitative household survey in Vienna. The data collection was carried out by telephone interviews with a total sample size of 977 participants which is representative for the Viennese population aged 14 and above. The duration of the interviews was 35 minutes and the content ranged from demographic data, spatial and building characteristics, general energy consumption (residential demand and mobility), attitudes to the environment, media consumption and typology items. The main goal was to identify types of homogeneous attitudes and behaviour in the field of mobility and residential energy consumption. The survey period extended from the middle of June to the end of July 2015.

The identification of the milieus based on the Sinus-Milieus® in Austria. This segmentation model is based on sociological models describing communities of basic values with shared attitudes concerning different aspects of everyday life (e.g. work, leisure, social relationships, consumption, politics etc.). Figure 2 illustrates the 10 Sinus milieus identified for Austria in 2013.

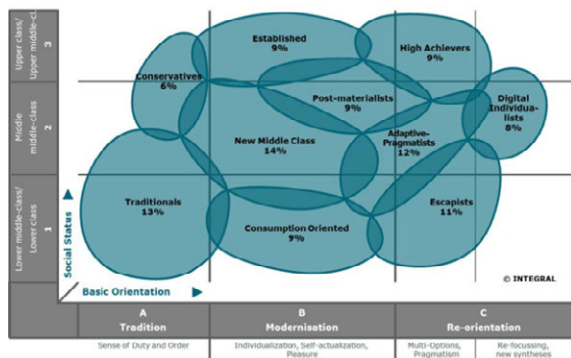

Fig.2: Sinus-Milieus in Austria 2013 [8].

In order to generate electrical load profiles, 977 representative answers from the survey across all milieus have been analysed. The focus here was not only on the behaviour such as when and what kind of electronic appliances do the participants use, but also on the context with building physics and certain energy consumption characteristics.

The most crucial process was an intensive review in terms of plausibility for all answers. Therefore, certain indicators (e.g. maximum number of specific appliances, maximum duration of usage min/week) have been established in order to over write obviously inappropriate answers rather than delete them. Otherwise the number of contradictions will decrease the quantity of useful answers to roughly one third.

$$n(i) = MV(i) \pm SD(i) \tag{1}$$

Equation (1) describes the procedure if answers seem to be inappropriate with respect to the indicators. Therefore, the mean value for that specific milieu (i) ± randomly the standard deviation for this question within that specific milieu has been used. In addition to the general attendances of the occupants, the participants indicate in order to generate time dissolved load profiles, not only the running time, but also the time of use. Equation (2) describes the power of all appliances for each time step and milieu.

$$Pi(t) = \sum_{i=1}^n Pn(t) \tag{2}$$

In total, 13 different appliances (e.g. televisions, notebooks, kitchen appliances, cell phones, household devices, etc.) have been considered.

Fig. 3 highlights the time dissolved differences regarding the social differential attendances compared to the mean value including the standard deviation. While each coloured line represents one milieu, the black line represents the mean value. It can be seen, that the general attendance within all milieus is much higher during the weekend.

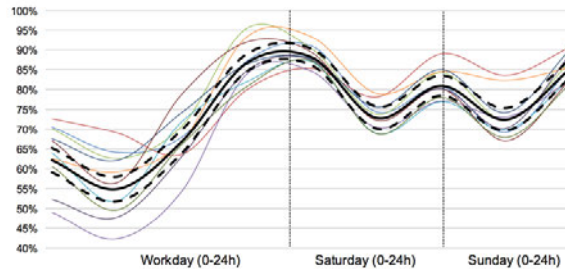

Fig. 3: Attendances for all 10 milieus compared to the mean value (continuous black line) including the standard deviation (dashed black lines) for a Workday, Saturday and Sunday.

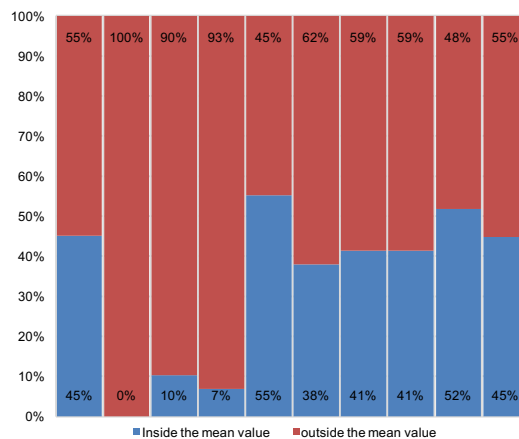

Fig. 4: Deviation of Attendances within the standard deviation for one week.

Fig. 4 indicates the deviation for all milieus regarding their match to the mean value including the standard deviation for one week. In average, 65% are outside that range. It also can be seen that one milieu has no match at all. Considering only a working day, 68% are outside that range, while 57% are outside within the weekend. The specific behaviour for different milieu effects the understanding of a time dissolved load profile significantly.

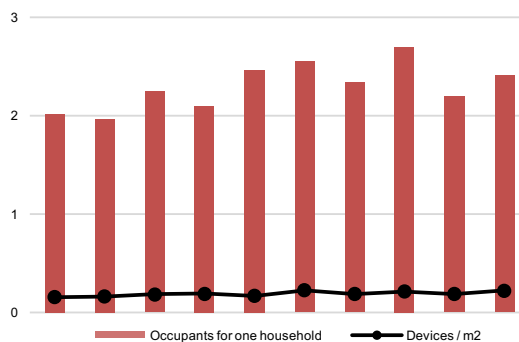

Fig. 5: Comparison between the number of occupants for one household to the number of devices per square meter.

While the deviation of the attendances for all milieus distinguish significantly, Fig. 5 emphasis that the number of devices for one square meter of household remains quite constant, even the

mean value of occupants differs a lot. As mentioned in the previous chapter, the plausibility of all data had a wide range. Therefore, Fig. 6 shows, that the mean value within all milieus for the running time in minutes per week seems to be realistic, even if some overestimated it.

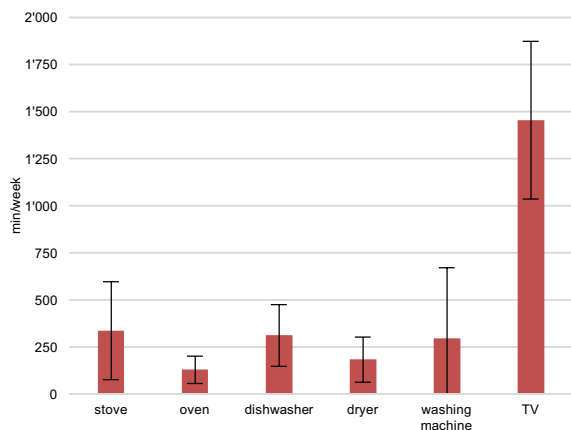

Fig. 6: Running time for 6 different appliances before the correction in the course of the plausibility review.

Therefore, some indicators for the maximum use for each appliance have been established and have been used to limit the maximum running time and thus, to overwrite overestimated values according to equation (1).

	Stove	Oven	Dishwasher	dryer	Washing-machine	TV
min/week	840	840	1680	840	420	3360

Tab. 1: Maximum running time for appliances in order to limit over estimated time specifications.

As Tab. 1 and Fig. 6 illustrate, the mean values are clearly below the limited values for the running time according to Tab. 1. It becomes clear, that only highly overestimated running times have been corrected according to equation (1).

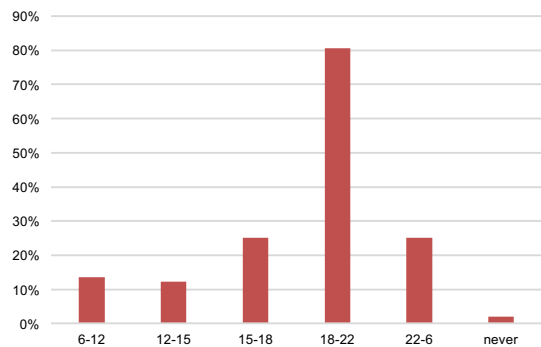

Fig. 7: Mean value within all milieus for the time of use on the example of televisions.

The same procedure has been done for the time of use for all appliances. In the course of the review process, only data with a mismatch compared to the general attendances for each answer has been over write. But in general, the distributed mean values for one day of televisions highlighted in Fig. 7, seems to be realistic.

#### 4 RESULTS

In order to create time and milieu dissolved electrical load profiles, four variables are necessary:

- (i) general attendance for each milieu (Fig. 3 and Fig. 4)
- (ii) the amount and type of appliances for each milieu (Fig. 5)
- (iii) running time for all appliances for each milieu (Fig. 6 and Tab. 1)
- (iv) time of use for all appliance for each milieu (Fig. 7)

Fig. 8 compares the annual electrical energy consumption for each milieu with statistic data from [9] with respect to the number of occupants for one household. It should be noted, that the energy consumption distinguishes within all milieus significantly. Comparing the deviation for all milieus to the statistic, the results ranges from -13% to 18%.

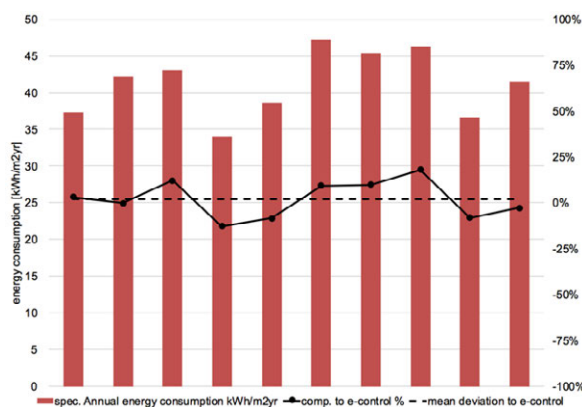

Fig. 8: calculated energy consumption for electrical appliances for all milieus compared to the statistics of e-control [9].

Although the number of appliances remains quite constant within all milieus, the calculated annual energy consumption ranges from 34 to 47 kWh/m<sup>2</sup>a. This is due to the fact of different running times and attendances within all milieus.

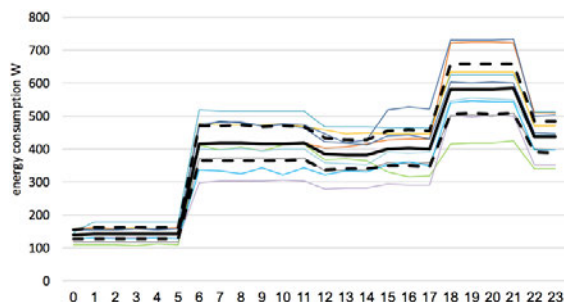

Fig. 9: Daily load profile for a week day considering the variance of all milieus compared to mean value (continues black line) and standard deviation (dashed black lines).

Fig. 9 puts all four variables into one daily load profile for each milieu compared to the mean value including the standard deviation. It is conspicuous that the electrical power differs not only during the evening, but also during the day. Furthermore, the peak load during the evening hours ranges from 400 to almost 800 Watts.

## 5 DISCUSSION

The results show, that the quality of the developed load profiles is definitely comparable to other research results [10,11], but by considering the variance of different milieus, the quantity differs a lot. In order to get a much better understanding concerning an aggregated load profile for residential buildings, the results can make a contribution towards load shifting, smart metering and not to mention demand side management. The results also highlighted the differences for different milieus regarding their behaviour and thus, their significant effects on that specific load profile. In addition, the results can be used for electrical grid operators for an improving load balancing towards the implementation of more decentralized energy storages and volatile renewable energy (e.g. Photovoltaics) within cities and districts. Therefore, further research will be to disaggregate the results for each milieu to highlight the effects and variances on a more detailed level, as well as to validate the results with well monitored buildings.

## 6 ACKNOWLEDGMENTS

This work is part of the PhD program “Urban Energy and Mobility Systems” (URBEM), which has been instituted by Wiener Stadtwerke Holding AG and the Vienna University of Technology. The aim is to research and to develop an interactive environment for analysing scenarios towards a sustainable, secure, affordable and liveable city by the example of the City of Vienna in a holistic and interdisciplinary approach. (<http://urbem.tuwien.ac.at>). The household survey in Vienna is part of the

scientific project “Simultan” supported by the Austrian Research Promotion Agency (FFG).

## 7 REFERENCES

1. Paatero, J. and P. Lund, A model for generating household electricity load profiles, *International Journal of Energy Research*, 2006. 30(5):273–290.
2. Lutzenhiser, L. and S. Bender, The “Average American” unmasked: Social structure and differences in household energy use and carbon emissions, in *ACEEE Summer Study on Energy Efficiency in Buildings 2008*.
3. Lutzenhiser, L. and S. Lutzenhiser, Looking at Lifestyle: The Impacts of American Ways of Life on Energy/Resource Demands and Pollution Patterns, in *ACEEE Summer Study on Energy Efficiency in Buildings 2006*.
4. Goldstein, D. and P. Fairey, *Energy Labeling & Energy Billing Analysis*. Home Energy 2010 (Jan/Feb):p. 14-15.
5. Peffer, T., W. Burke and D. Auslander. ResPoNSe: Modeling the Wide Variability of Residential Energy Consumption, in *ACEEE Summer Study on Energy Efficiency in Buildings 2010*.
6. Haufe, N. and J. S. Dangschat, *Energiekonsum – sozial differenziert betrachtet. Eine Reflektion lebensstil- und milieuorientierter Ansätze zur Beschreibung und Erklärung unterschiedlicher Energieverbrauchsmuster privater Haushalte*, in Großmann, K., A. Schaffrin and C. Smigiel (Hrsg.): *Energie und soziale Ungleichheit: Zur gesellschaftlichen Dimension der Energiewende in Deutschland und Europa*. 2016, Wiesbaden: Springer: p. 633-660
7. Hradil, S., Lagen und Milieus Sozialstrukturanalyse in einer fortgeschrittenen Gesellschaft, in: Solga, H., J. Powell and P. A. Berger, *Soziale Ungleichheit. Klassische Texte zur Sozialstrukturanalyse*. 2009, Frankfurt/ New York: Campus Verlag: p. 281-312.
8. INTEGRAL, Sinus-Milieus® in Österreich 2013, in [http://www.integral.co.at/de/sinus/milieus\\_at.php](http://www.integral.co.at/de/sinus/milieus_at.php).
9. E-control Austria, Statistic values for the mean electrical energy consumption 2016, in [www.e-control.at](http://www.e-control.at).
10. Ghaemi, S., *Efficiency Potential in Private Sector in ADRES (Dissertation)*. 2011, Wien: TU Wien.
11. Hauser, W., *Analysis and Agent-Based Modelling of Lifestyle Aspects Influencing the Residential Energy Demand in France and Germany (Dissertation)*. 2013, Stuttgart: University Stuttgart.







## Expanding Boundaries: Systems Thinking for the Built Environment

### A METHODOLOGY FOR ENERGY AUDIT FOR COMMERCIAL BUILDINGS USING MACHINE LEARNING TOOLS

C. Deb<sup>1\*</sup>, S. E. Lee<sup>1</sup>, J. Yang<sup>1</sup>, K. W. Shah<sup>1</sup>

<sup>1</sup> Department of Building, National University of Singapore, Singapore

\*Corresponding author; e-mail: chirag.deb@u.nus.edu

#### Abstract

Energy auditing is a process for evaluating energy conservation opportunities in buildings. According to ASHRAE standards, energy audits can be performed at three levels based on the extent of the audit scope. This requires extensive assessment arrangements including instrumentation and data collection, data analysis and identifying energy saving potential of the building systems. However, these steps make the audit process time consuming and often expensive. This study presents an ongoing methodology that aims to enhance the audit process through a data driven approach. Building and energy related data from 24 commercial buildings is used to develop the methodology by analysing their energy audit reports. Several building factors that influence energy consumption have been analysed and ranked based on their correlation coefficients. An energy savings prediction model is developed using Artificial Neural Network (ANN) based on the energy savings data as gathered from the 24 audit reports. The results show that the ANN model predicts the energy savings accurately for a building by simply using the basic building data. The details of the ANN model development have also been highlighted. It is also intended to expand the dataset to about sixty buildings to make the results more accurate.

#### Keywords:

Energy auditing; Prediction model; Artificial Neural Networks; Building energy consumption

## 1 INTRODUCTION

The International Energy Agency has identified energy efficiency in buildings as one of the five measures to secure long-term decarbonisation of the energy sector (© OECD/IEA 2015 *World Energy Outlook Special Report*, IEA Publishing. License:

[<http://www.iea.org/t&c/termsandconditions/>] [1]. Along with environmental benefits, building energy efficiency also presents vast economic benefits. Buildings with efficient energy systems and management strategies have much lower operating costs. Many countries have now accelerated the implementation of energy codes and regulations for various building types. These regulations outline basic requirements to achieve an energy efficient design for new buildings with a view to reduce the final energy consumption and related CO<sub>2</sub> emissions. In addition, many computer softwares have also been developed and widely implemented for energy efficient

design of new buildings. Some of the most popular ones are EnergyPlus, DOE-2, eQUEST, IES, ECOTECT etc. However, once the building is functional, the energy behavior of a building is governed by many factors such as weather conditions, occupancy schedule and behavior, thermal properties of building materials, complex interactions of the energy systems like HVAC and lighting etc. Due to these complex interactions, accurate, computation of energy consumption is very difficult. For these reasons, data driven techniques for building energy analysis of existing buildings are very crucial. These techniques are based on past recorded data and building factors like Gross Floor Area (GFA), occupancy etc.

### 1.1 Energy Auditing

Energy audits are the first step to improve the energy efficiency of buildings and industrial facilities. Generally, three levels of energy audits

can be distinguished as outlined by ASHRAE standards [2]:

- Walk-through audit - consisting typically of a short on-site visit of the facility to identify areas where simple and inexpensive actions can provide immediate energy use and operating cost savings. Usually it also involves utility cost analysis that includes a careful evaluation of metered energy uses and operating costs of the facility. Typically, the utility data over several years are evaluated to identify the patterns of energy use, peak demand, weather effects, and potential for energy savings.
- Standard energy audit - consisting of a comprehensive energy analysis for the energy systems of the facility. In particular, the standard energy audit includes the development of a baseline for the energy use of the facility and the evaluation of the energy savings and the cost effectiveness of appropriately selected energy conservation measures.
- Detailed energy audit – considered the most comprehensive and time-consuming energy audit type. It includes the use of instruments to measure energy use for the whole building and for some energy systems within the building (for instance by end uses: lighting systems, office equipment, fans, chillers, etc.). In addition, sophisticated computer simulation programs are typically considered for detailed energy audits to evaluate and recommend energy retrofits for the facility.

The purpose of the audit is to identify energy conservation measures (ECMs). Several tools have been developed to aid the audit process. Hong et al. [3] presented the Commercial Building Energy Saver (CBES), an energy retrofit analysis toolkit. This tool calculates the energy use of a building, identifies and evaluates retrofit measures in terms of energy savings, energy cost savings and payback. The CBES Toolkit includes a web app (APP) for end users and the CBES Application Programming Interface (API) for integrating CBES with other energy software tools. Hestnes and Kofoed [4] evaluated a set of retrofitting strategies designed for ten existing office buildings. This was done by examining different low energy retrofitting measures in terms of energy, indoor environment, and economy, and by using this as a basis for the development of general retrofitting strategies and design guidelines. Chuah et al. [5] introduced ROBESim (Retrofit-oriented building energy simulator). ROBESim is based on the popular EnergyPlus framework, and relies on EnergyPlus for most of the supported computations. By using the retrofit modules in ROBESim, the user can quickly and easily generate building models to perform retrofit comparison simulations. A recent review by Lee

et al. [6] has divided such existing retrofitting tool into three divisions:

- Toolkits with empirical data-driven methods
- Toolkits using normative calculations
- Toolkits with physics-based energy modelling and simulation

The data-driven methods have been widely used to predict building energy usage, from simple benchmarking to more complex regression modelling. These models rely on past recorded data for energy consumption and operational parameters. Among these methods, the most widely implemented in modelling and forecasting is the machine learning method, which predominantly includes Artificial Neural Network (ANN) and Support Vector Machine (SVM) [7][8][9][10]. This study utilizes the ANN model that has gained momentum in building energy consumption studies for its application ranging from forecasting to prediction of saving potential for buildings. The objective of this study is to develop a prediction model for energy savings in commercial buildings using a data-driven approach. For this, 24 building energy audits have been analyzed and used to develop the prediction model using ANN. More details on the ANN methodology and the design of its parameters is presented in the next section.

## 2 METHODOLOGY

### 2.1 Data collection

This study is based on data collected from accredited Energy Service Companies (ESCOs) in Singapore. The data collection for model development involves reviewing through the energy audit reports as are provided by three such ESCOs. For cases where data is unavalible or inconsistent across audit reports, linear regression or averaging is usually used to impute the missing values. However, in the cases studied, all data were available. An energy audit report contains detailed analysis of energy distribution and usage by the various energy consuming systems in a building. The three major energy consuming systems in a building are the following:

- (i) Air Conditioning
- (ii) Lighting
- (iii) Plug loads

These three systems account for more than 80% of the total energy consumed in a building. The air conditioning system is the major energy consuming system (about 55% of total energy) out of the above three and is the central focus for this part of the study. The air conditioning system comprises of two parts. First is the chiller plant room and the second are the Air Handling Units (AHUs). Depending on the building configuration, there are different divisions for the amount of energy consumed by the chiller plant and the

AHUs. For a typical office building with central chiller plant, the amount of energy consumed by the chiller plant, (that includes the chiller power, chilled water pumps, condenser water pumps) corresponds to 60-70% of the air conditioning energy use. The rest is consumed by the AHUs. Along with the air conditioning energy use data, several building factors that influence building energy consumption and energy saving potential have been identified and studied for model development. The list of the eight factors studied is presented in the 'Results' section.

## 2.2 Artificial Neural Network (ANN) model

ANN is an intensely parallel network of processing units that can perform non-linear analysis. They learn the relationship between input and output variables by studying previously recorded data through a process called training. An ANN resembles the biological neural system, composed by layers of parallel elemental units, called neurons. The neurons are connected by a large number of weighted links, over which signals or information passes through. A neuron receives inputs over its incoming connections, combines the inputs, performs generally a non-linear operation, and then outputs the final results. In this study, the neural network adopted was a feed-forward multi-layer perceptron (MLP), which is among the most commonly used neural networks that learn from examples. A schematic diagram of the basic architecture is shown in Figure 1. It contains three layers – the input, hidden and output layers. Each layer is interconnected together by the connection strengths called weights. The training algorithm used in this study is the Levenberg-Marquardt (LM) algorithm. This algorithm performs well with function approximation problems like the one being dealt in this study. The learning process in an ANN involves determining the weight vectors. There are various algorithms that are used for this purpose. The aim of the training process is to minimize the squared error between the predicted and the measured outputs (1).

$$E = \sum_2^1 (O_p - O_m)^2 \quad (1)$$

Here, E is the total error,  $O_p$  is the predicted output and  $O_m$  is the measured or desired output. E is minimized by the gradient descent method which involves computing the partial derivative of E with respect to each weight in the network. The most popular training algorithm is the backpropagation algorithm and its details can be found in the work of Rumelhart et al [11]. Once the weights are determined using this backpropagation method, the ANN model is considered ready and can be tested for new data cases.

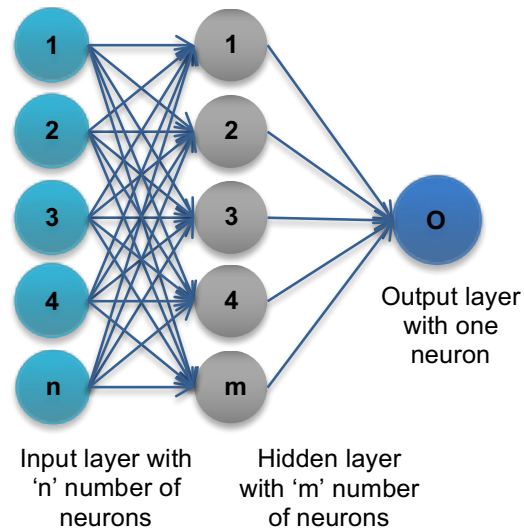

Fig. 1: A typical ANN structure with input, hidden and output layers.

## 3 RESULTS AND DISCUSSION

The mathematical modelling using ANN requires a set of dataset with certain inputs and their corresponding outputs. This input-output matrix is used to map the relationship between input and output variables by computing the weights of the connections. The connections are present between the inputs and the neurons in the hidden layer as well as the neurons between the hidden and the output layer. For model training and testing, 16 and 8 audit reports have been assigned respectively. The first step in ANN modelling is to determine the input-output matrix that is then used to train the model. The output in this case is fixed at the potential energy savings as proposed by the ESCOs in their audit reports of the buildings. To determine the inputs for the ANN model, an approach which deals with analyzing each variable independently is employed. The variables associated with the energy performance of each building that are collected from the ESCOs are eight different variables or factors. However, it is important to select only the most important variable and use them as inputs for the ANN model development. A preliminary analysis was performed to determine these variables and the following results are obtained, as presented in Table 1.

Energy Indicator	R <sup>2</sup>
Annual electricity consumption	0.58
Average cooling load per day (RT)	0.86
Energy Use Index (EUI)	0.52
Chilled water supply temperature	0.37

Chilled water return temperature	<b>0.33</b>
Gross Floor Area (GFA)	<b>0.88</b>
Chiller plant efficiency	<b>0.88</b>
Operation hours	<b>0.27</b>

Table 1. Correlation coefficients ( $R^2$ ) of energy indicators with measured potential savings.

The correlation of the GFA with the potential savings calculation yields a positive and high coefficient of determination ( $R^2 = 0.88$ ) as seen in Figure 2. This shows that there is a good correlation in the given dataset between the GFA of a building and the amount of energy that can be saved by retrofitting the facility. It is normally seen that a large facility has a much wider scope of energy conservation possibility because the facility requires high capacity building systems like air conditioning and lighting system. In such cases, even a simple retrofitting solution, like changing the fluorescent ballast lamps to LED (Light Emitting Diodes) could lead to a high saving potential. Similarly, for the air conditioning system, the larger GFA, in most cases ensures more potential savings unless there is an entire change in the air conditioning system.

Another variable that provides an estimate on the potential savings is average cooling load per day for a building. If the buildings that belong to a similar cluster of GFA have variation in their average daily cooling load, it shows that either the buildings differ heavily in occupancy numbers or that one of the buildings have high cooling load for other reasons. For the data on 16 buildings with water-cooled chiller water system, shows that there is a direct correlation between these two variables with a  $R^2 = 0.88$ . Therefore, the average cooling load is also considered as an input for the ANN model. A similar correlation is observed between the chiller plant efficiency and potential savings. The BCA Platinum green mark rating chiller plant efficiency target for non-residential buildings with a cooling load more than 500 RT is 0.65. Going with this target, there seem to exist a high potential for energy savings based on improving the chiller plant efficiency only.

The three inputs selected for developing the ANN model are the GFA, average cooling load and the

chiller plant efficiency. These constitute the input layer with three neurons corresponding to the three inputs and the output neuron as the predicted potential saving (Figure 3). The LM training algorithm is used to train the model by using the data provided by the ESCOs for eight buildings. The data is divided into 16 buildings data for training and 8 buildings data for testing the model. Figure 4 shows the correlation between the predicted savings by the model and the ones as proposed by the ESCOs. The correlation coefficient of the predicted savings by the ESCOs and that predicted by the model is 0.94. Although this correlation is high, it is to be noted that this is for the training dataset and does not any testing with an independent set of testing data. ANNs are very good in accurately modelling the training data and such a high correlation should not be taken as evidence of an accurate model. The model developed is accurate for the data set involved in training alone. However, the dataset is currently being expanded and it is targeted to obtain the audit report data for another fifty buildings. Once the dataset is updated, it is targeted to partition the dataset into data for training and testing and validating the model.

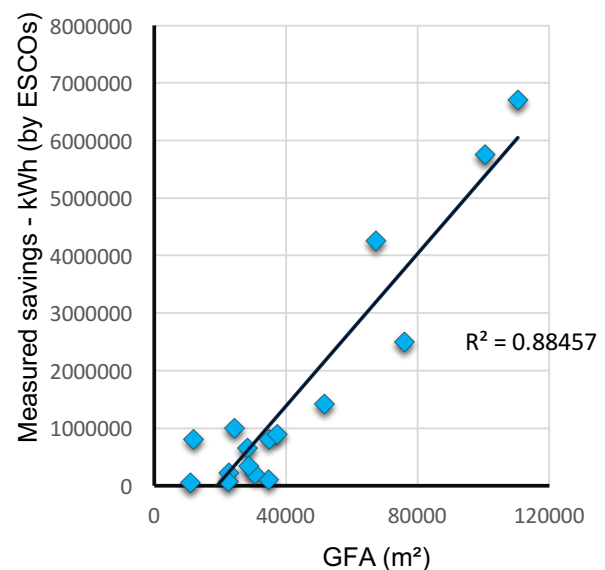

Fig. 2: Correlation of GFA with energy saving potential of a building as measured by the ESCOs.

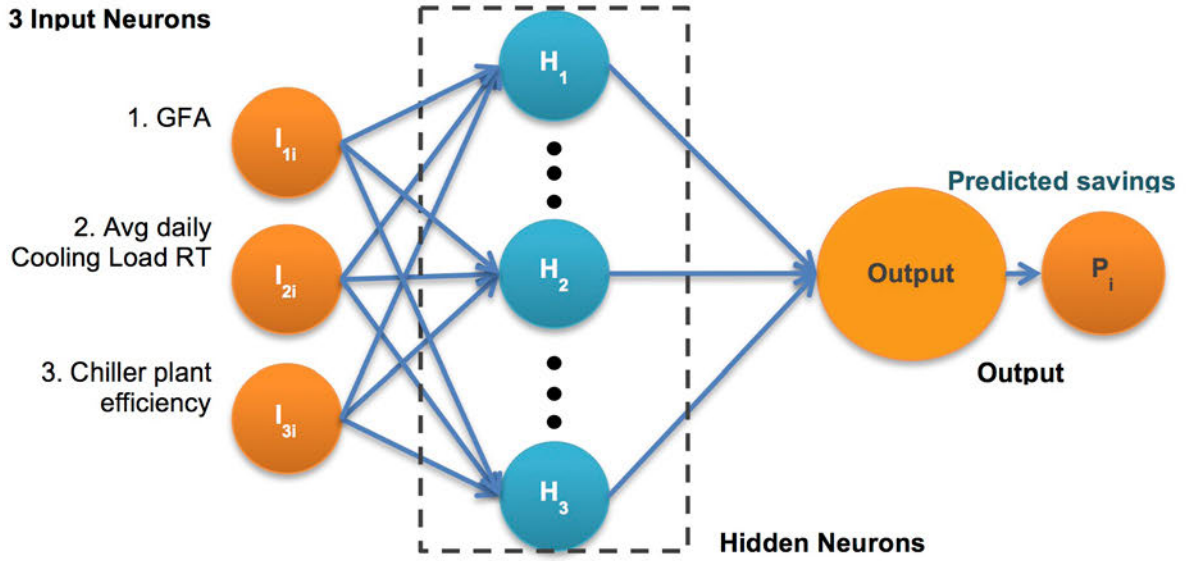

Fig. 3: The ANN structure for predicted savings potential.

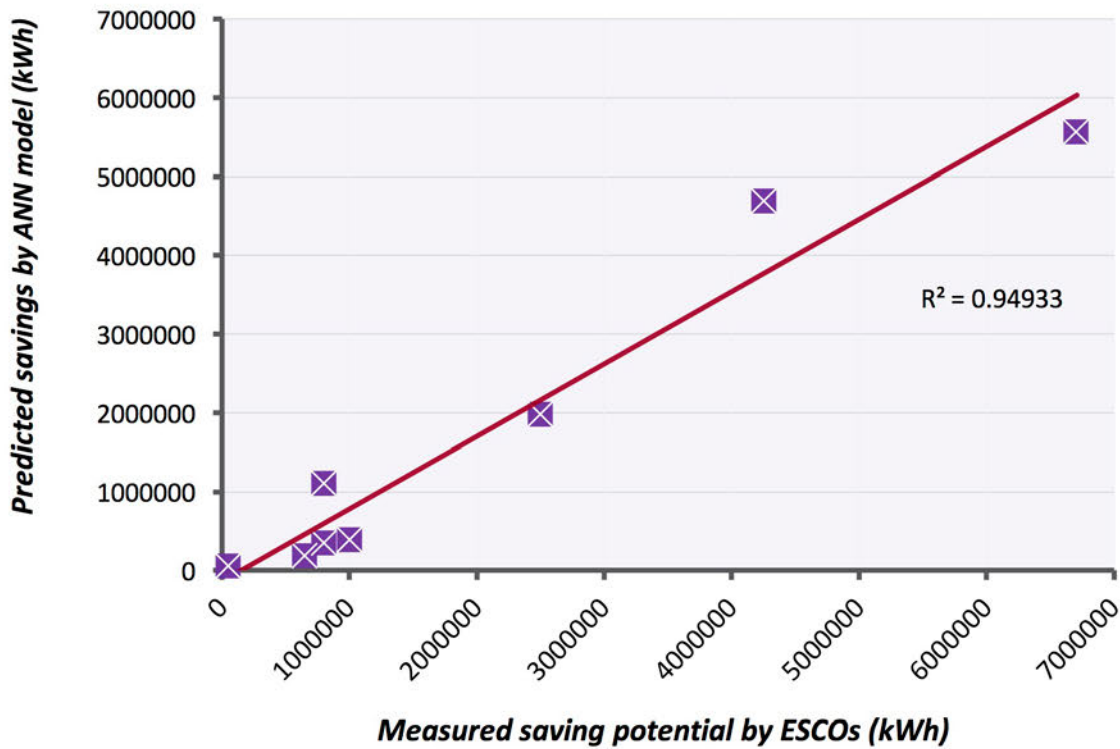

Fig. 4: Correlation between the measured savings by the ESCOs and the predicted savings by the ANN model.

#### 4 SUMMARY

A detailed data-driven method using ANN is developed to predict the energy saving potential of a building. For this, 24 energy audit reports from 3 ESCOs are analysed and used to develop the prediction model. The inputs that have been selected are the GFA, average cooling load per day and chiller plant efficiency which exhibit  $R^2$  values of 0.88, 0.86 and 0.88 respectively with potential savings. The model is trained using data from eight buildings. The developed model shows an accuracy of 0.94 between the potential accuracy as proposed by the ESCOs and the potential saving as predicted by the model. Such a model is expected to enhance the audit process by providing a guideline for potential savings calculation using simple building energy indicators like GFA, chiller plant efficiency etc. The process of expanding the dataset and data collection is underway with audit report data from another 50 buildings to be added to the dataset. Once the dataset is expanded, the accuracy of the model is also expected to improve.

#### 5 ACKNOWLEDGEMENTS

The authors would like to thank the 4 ESCOs (G-Energy Pte Ltd; E2Green Pte Ltd; LJ Energy Pte Ltd; and EMSI Pte Ltd) for their collaboration and support to this study.

#### 6 REFERENCES

1. IEA. Energy and climate change. 2015. doi:10.1038/479267b.
2. ASHRAE. Procedures for Commercial Building Energy Audit. Second Edi. Atlanta, USA: 2004.
3. Hong T, Piette MA, Chen Y, Lee SH, Taylor-Lange SC, Zhang R, et al. Commercial Building Energy Saver: An energy retrofit analysis toolkit. *Appl Energy* 2015;159:298–309. doi:10.1016/j.apenergy.2015.09.002.
4. Hestnes AG, Kofoed NU. Effective retrofitting scenarios for energy efficiency and comfort: results of the design and evaluation activities within the OFFICE project. *Build Environ* 2002;37:569–74. doi:10.1016/S0360-1323(02)00003-3.
5. Chuah JW, Raghunathan A, Jha NK. ROBESim: A retrofit-oriented building energy simulator based on EnergyPlus. *Energy Build* 2013;66:88–103. doi:10.1016/j.enbuild.2013.07.020.
6. Lee SH, Hong T, Piette MA, Taylor-Lange SC. Energy retrofit analysis toolkits for commercial buildings: A review. *Energy* 2015;89:1087–100. doi:10.1016/j.energy.2015.06.112.
7. Zhao H, Magoulès F. A review on the prediction of building energy consumption. *Renew Sustain Energy Rev* 2012;16:3586–92. doi:10.1016/j.rser.2012.02.049.
8. Deb C, Eang LS, Yang J, Santamouris M. Forecasting diurnal cooling energy load for institutional buildings using Artificial Neural Networks. *Energy Build* 2015.
9. Deb C, Eang LS, Yang J, Santamouris M. Forecasting Energy Consumption of Institutional Buildings in Singapore. *Procedia Eng* 2015;121:1734–40. doi:10.1016/j.proeng.2015.09.144.
10. Dong B, Cao C, Lee SE. Applying support vector machines to predict building energy consumption in tropical region. *Energy Build* 2005;37:545–53. doi:10.1016/j.enbuild.2004.09.009.
11. Rumelhart DE, Hinton GE, Williams RJ. Learning representations by back-propagating errors. *Nature* 1986;323:533–6. doi:10.1038/323533a0.



## Expanding Boundaries: Systems Thinking for the Built Environment

### OVERHEATING REDUCTION OF A COLD FORMED STEEL-FRAMED BUILDING USING A HYBRID EVOLUTIONARY ALGORITHM TO OPTIMIZE DIFFERENT PCM SOLUTIONS

A. Figueiredo<sup>1\*</sup>, R. Vicente<sup>1</sup>, J. Kämpf<sup>2</sup>, C. Cardoso<sup>1</sup>, J.-L. Scartezzini<sup>2</sup>, F. Rodrigues<sup>1</sup>

<sup>1</sup> RISCO – Department of Civil Engineering, University of Aveiro, Portugal, Campus Universitário de Santiago, Aveiro, 3810-193 Aveiro, Portugal

<sup>2</sup> Solar Energy and Buildings Physics Laboratory (LESO-PB), École Polytechnique Fédérale de Lausanne (EPFL), Lausanne, Switzerland

\*Corresponding author; e-mail: ajfigueiredo@ua.pt

#### Abstract

Cold formed steel-framed constructions have been strongly disseminated with particular emphasis on the residential sector due to their fast execution, quality control and final cost. However, this construction typology presents a weakness associated with a low thermal inertia and a consequential risk of overheating.

The present research addresses the overheating rate reduction of a cold formed steel-framed building located in the coastal region of mainland Portugal, a particular environment considering the combination of the high outdoor temperature amplitude and the lack of thermal inertia of such building typology. To overcome this weakness, different phase change materials solutions (PCMs) were incorporated into the partition walls and ceilings of south oriented compartments. Thus, thermal energy storage provided by the PCMs solutions play a crucial role in the indoor thermal regulation of the building by minimizing indoor temperature peaks and amplitude improving indoor thermal comfort with lower energy demand.

To optimize the PCM solution in order to reduce the rate of overheating, a hybrid evolutionary algorithm was used in conjunction to the EnergyPlus® simulation engine, adapting a list of parameters. This study was extended to identify the best PCM solution to minimize, in some cases prevent, the overheating risk for different climate applications in Portugal mainland.

The results attained reveal the possibility to reduce the overheating risk by up to 89% in highly glazed south faced compartments and 23% in north orientated compartments. In terms of heating energy demand, a reduction of 17% was also attained, triggered by the PCM storage effect.

#### Keywords:

Phase Change Materials; Low Inertia; Cold formed steel-framed; Energy Efficiency; Evolutionary Algorithms

## 1 INTRODUCTION

In the near past (2000 – 2009 period), the energy consumption in EU (European Union) buildings has not changed significantly, however, in South Western European countries the cooling energy demand has increased [1, 2].

In the pursuit of energy savings and thermal comfort, the implementation of new materials and constructive solutions are required in the construction sector. Recent research in this field

particularly aimed at cooling demand reduction, is focusing on the following constructions components and strategies that are linked to renewable energy sources: reflective pavements, permeable and water retentive pavements, passive evaporative cooling walls, heat absorbing phase change materials (PCMs), cool roofing materials, green facades and green roofs, night ventilation, ground cooling and floor slab cooling [3-7]. In order to investigate these further, this

paper explores how the optimization of the building features such as: bypass ventilation air flow capacity; bypass temperature activation; three different window solutions (including double and triple glazing) in combination with thirteen possible PCM solutions with different melting points and latent heat capacity for the partition walls and ceilings of internal compartments south oriented, can be used for overheating reduction.

## 2 METHODOLOGY

The presented methodology consists in the use of a multi-objective evolutionary algorithm to optimize the building's features with low thermal inertia, with overheating reduction as a goal. To fulfil this goal, dynamic thermal simulation of a cold formed steel-framed detached building was carried out using EnergyPlus® 8.3.0 (EP) software.

The first step starts by a building thermal performance characterization of the original constructive solution (without new features application). In the second step the following features were applied in the model and a thermal characterization was performed and compared with the results attained from the original solution:

- (i) A mechanical ventilation system with heat recovery capacity was specified.
- (ii) Three different windows solutions were tested.
- (iii) Natural ventilation with an air flow rate regulator in  $\text{h}^{-1}$  was specified.
- (iv) Ventilation by-pass air flow rate was controlled to react to a pre-defined indoor temperature value.

In the third step, thirteen different PCM solutions were combined in the South orientated surfaces and ceiling. In this step the thermal performance was optimized and evaluated and finally, compared with the attained results from the first and second steps.

In the last step the influence of a mix PCM solution combining two PCMs with different melting temperature was evaluated.

## 3 CASE STUDY: CHARACTERIZATION

The case study building is located in Aveiro at about 5 km from the centre city and 10 km from the Atlantic coast, in North central of Portugal. The building consists of a two-story prefabricated cold formed steel-framed construction with a treated floor area of  $148 \text{ m}^2$  and the global percentage of glazing of 16.4% in respect to opaque façade area. The glazing oriented to the Northeast represents a relative percentage of the total glazed area of 32.3%, and 58.7% to Southwest (see Figure 1).

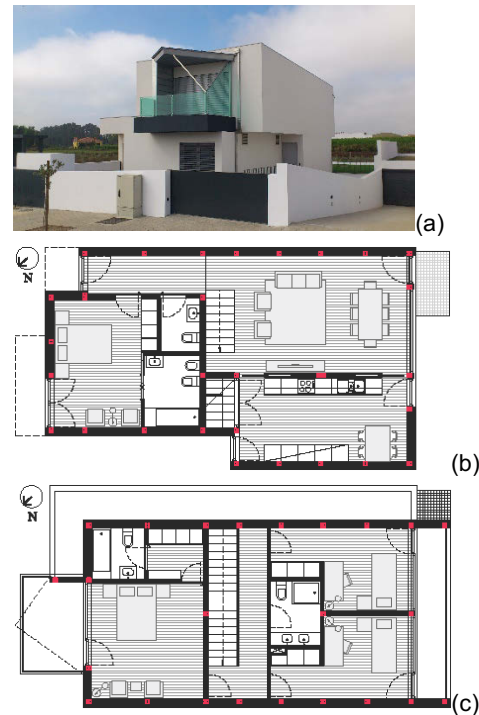

Fig. 1: Architectural blueprints: (a) 3D view; (b) ground floor (c) elevated floor.

The building's external envelope is mainly composed of the followings elements: Ground floor slabs -  $U_{\text{value}} = 0.78 \text{ (W/m}^2 \text{ °C)}$  and IT (insulation thickness) = 30 (mm); Façade walls -  $U_{\text{value}} = 0.33 \text{ (W/m}^2 \text{ °C)}$  and IT = 60 (mm); Flat roof -  $U_{\text{value}} = 0.36 \text{ (W/m}^2 \text{ °C)}$  and IT = 50 (mm).

Windows modelled have a Solar Heat Gain Coefficient (SHGC) of 0.53 and  $U_{\text{value}}$  of  $1.79 \text{ (W/m}^2 \text{ °C)}$  for the glazing to the Northeast and  $U_{\text{value}}$  of  $1.68 \text{ (W/m}^2 \text{ °C)}$  to the Southwest.

## 4 DYNAMIC THERMAL SIMULATION MODEL

Figure 2 shows the SketchUp® model constructed with the OpenStudio plugin, which is a graphical interface used to reproduce the geometry of the model and the thermal zoning division. The annual thermal behaviour of the building was simulated and calculated resorting to EnergyPlus® software considering the conduction transfer function (CTF) model for the algorithm of surface heat balance calculation. A detached multi-zone model was assembled using eight thermal zones corresponding to the internal compartments of the building (see Figure 2).



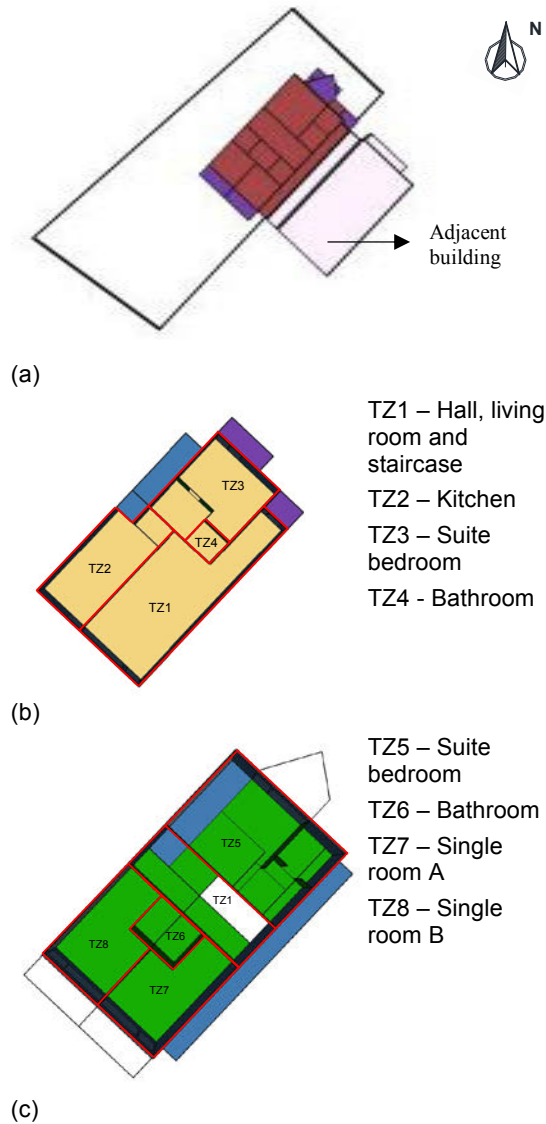

Fig. 2: OpenStudio model geometry:  
 (a) 3D view; (b) Ground floor thermal zones  
 (c) 1<sup>st</sup> floor thermal zones.

## 5 RESULTS AND GENERAL DISCUSSION

### 5.1 Thermal behaviour characterization (1<sup>st</sup> step)

The original building was simulated considering an ideal air system that meets heating for a setpoint of 20 °C as minimum indoor temperature to activate the system using an ACR (air change rate) of 0.6 h<sup>-1</sup>. During the summer season the building characterization was evaluated in terms of an overheating rate considering a mechanical ventilation system with the capacity to provide a constant air flow from the outdoor air of 0.6 h<sup>-1</sup> without the capacity of air-conditioning.

The results attained were 36.26 (kWh/m<sup>2</sup>.a) for heating demand during the heating season and 15.23% of overheating in accordance with the EN 15251 standard during the summer season.

### 5.2 Thermal behaviour assessment – improvement and optimization (2<sup>nd</sup> step)

As the original building demands in terms of energy and overheating are important, an optimization process was carried out in order to assess and achieve improved models with a better thermal response.

Passive and hybrid techniques were applied only by changing and optimizing the window solutions, adding a heat recovery air system with capacity to work in by-pass mode increasing the total air flow rate, and by-pass with a temperature control activation based on the indoor air temperature.

The improvements were applied to the model, resorting to an evolutionary algorithm that instructs the software used in the simulations. In the present study (in this step) the parameters used in the optimization process are defined as continuous and discrete variables (see Table 1).

Continuous variables		
Parameter id.	Designation	Box Constraints
x0	Bypass Air flow rate (h <sup>-1</sup> )	0.00 – 2.44
x1	Bypass activation temperature (°C)	21 - 25
Discrete variables		
x2 (windows North orientated)	Window Solution (W/m <sup>2</sup> °C) ; SHGC	U <sub>value</sub> = 1.79 SHGC = 0.53
		U <sub>value</sub> = 0.94 SHGC = 0.61
		U <sub>value</sub> = 0.70 SHGC = 0.42
		U <sub>value</sub> = 1.68 SHGC = 0.53
x3 (windows South orientated)	Window Solution (W/m <sup>2</sup> °C) ; SHGC	U <sub>value</sub> = 0.90 SHGC = 0.61
		U <sub>value</sub> = 0.65 SHGC = 0.42

Table 1: List of parameters.

As objective functions, heating demand and overheating rate were chosen to be minimized by the optimizer. Overheating rate was defined in EP in accordance with EN 15251(category II) [8] and resourcing to Energy Management System (EMS) feature in EP that provides a way to develop custom control and modelling routines.

With this optimization (using the parameters defined in Table 1), higher reductions in heating demand and a significant reduction in the discomfort rate were achieved, when compared to the original solution. The energy and discomfort limits assigned in the plot are indicators of a building with high energy efficiency

in accordance with the PH (Passive House) standard.

From Figure 3 it is possible to depict the improvement attained in respect to the discomfort rate and heating demand reduction.

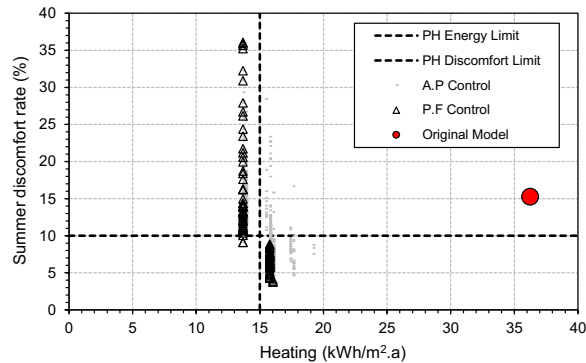

Fig. 3: Optimized results: 1<sup>st</sup> and 2<sup>nd</sup> step (A.P - All Points; P.F - Pareto Front).

### 5.3 Thermal behaviour assessment – PCM solutions and optimization (3<sup>rd</sup> step)

In this part of this study the initial priority was to prevent overheating during the summer period attaining simultaneously higher thermal comfort levels also using PCM in the constructive solutions.

A layer of PCM was incorporated into the partition walls and ceiling (positioned after the first layer in the wall solution) in the compartments with Southwest orientation (TZ1; TZ2; TZ7; TZ8). The following thirteen PCM solutions were implemented and tested:

- (i) Micronal® DS 5001 with a melting point of 21 °C and an overall enthalpy capacity of 244960 (J/kg) [9];
- (ii) BioPCM® series M27 with 21, 23, 25 and 27 different melting point and 289545, 300420, 322285, 322093 overall enthalpy capacity respectively [10];
- (iii) BioPCM® series M51 [10];
- (iv) BioPCM® series M91 [10].

The results presented in Figure 4 contain the points of the Pareto front (black triangles and black circular shapes markers) which represent a set of optimal solutions.

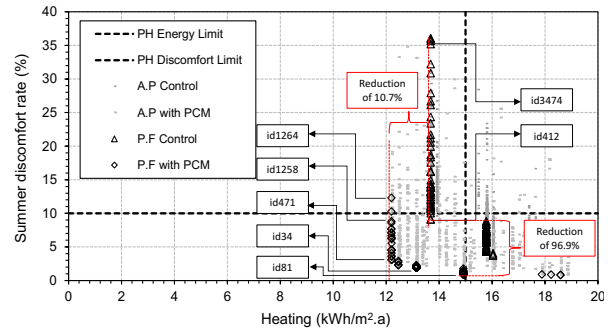

Fig. 4: Optimized results: 3<sup>rd</sup> step

Through the results, shown in Figure 4, it was observed that the use of PCM solutions has a significant impact during the summer season in the overall overheating reduction (67.1% of reduction). During the heating season, the PCM effect resulted in a heating demand reduction of 10.7%.

Tables 2 and 3 list some of the best solutions after optimization analysis. From Table 2 the main conclusion is the direct relationship between the bypass air flow rate and activation temperature with the summer discomfort rate. A bypass system that works in anticipation (reacting to lower temperature) is a good solution for overheating reduction. Table 3 shows that the best solution in terms of overheating reduction requires the bypass air flow rate at its maximum capacity with a temperature activation of 20.54 °C using BioPCM type M91 with a melting point of 25 °C. Other important conclusions are related with the windows solutions. When the main concern is the summer discomfort rate reduction, windows with low  $U_{value}$  and SHGC are required for south orientation. For the north orientation this requirement is more permissible to use higher  $U_{values}$ .

### 5.4 Thermal behaviour assessment – Mix PCM solutions and optimization (4<sup>th</sup> step)

Focusing on the issue of overheating risk and the fact that the PCM is not totally discharged (in a daily cycle), an additional analyse was carried out using a new constructive solution incorporating a mix of two PCMs with different melting points.

Figure 5 presents the results from the optimization.

Optimizer. id#	Bypass Air flow rate (h <sup>-1</sup> )	Bypass activation (°C)	Windows solution north (W/(m <sup>2</sup> °C))	Windows solution south (W/(m <sup>2</sup> °C))	Heating demand (kWh/m <sup>2</sup> a)	Summer discomfort rate (%)
Id3474	0.10	24.66	$U_{value} = 0.94$ SHGC = 0.61	$U_{value} = 0.90$ SHGC = 0.61	13.67	35.95
Id412	2.13	20.15	$U_{value} = 0.94$ SHGC = 0.61	$U_{value} = 0.90$ SHGC = 0.61	13.67	10.03

Table 2: List of solutions in the models without PCM use.

Optimizer. id#	Bypass Air flow rate ( $\text{h}^{-1}$ )	Bypass activation ( $^{\circ}\text{C}$ )	Windows solution north ( $\text{W}/(\text{m}^2 \text{ } ^{\circ}\text{C})$ )	Windows solution south ( $\text{W}/(\text{m}^2 \text{ } ^{\circ}\text{C})$ )	PCM type	Heating demand ( $\text{kWh}/\text{m}^2 \text{ a}$ )	Summer discomfort rate (%)
id1264	1.20	20.07	$U_{\text{value}} = 0.94$ SHGC = 0.61	$U_{\text{value}} = 1.68$ SHGC = 0.53	BioPCM M51/Q21/E0.021*	12.31	12.19
id1258	2.16	22.80	$U_{\text{value}} = 0.94$ SHGC = 0.61	$U_{\text{value}} = 0.90$ SHGC = 0.61	BioPCM M91/Q21/E0.037*	12.20	8.58
id471	2.44	20.00	$U_{\text{value}} = 0.94$ SHGC = 0.61	$U_{\text{value}} = 0.90$ SHGC = 0.61	BioPCM M91/Q21/E0.037*	12.21	3.07
id34	2.44	20.07	$U_{\text{value}} = 0.94$ SHGC = 0.61	$U_{\text{value}} = 0.90$ SHGC = 0.61	BioPCM M91/Q25/E0.037*	13.13	1.94
id81	2.44	20.54	$U_{\text{value}} = 1.79$ SHGC = 0.53	$U_{\text{value}} = 0.90$ SHGC = 0.61	BioPCM M91/Q25/E0.037*	14.92	1.11

\* Nomenclature used: M (Btu thermal energy storage capacity); Q (peak melting temperatures in degrees Celsius); E (thickness).

Table 3: List of solutions in the models with PCM.

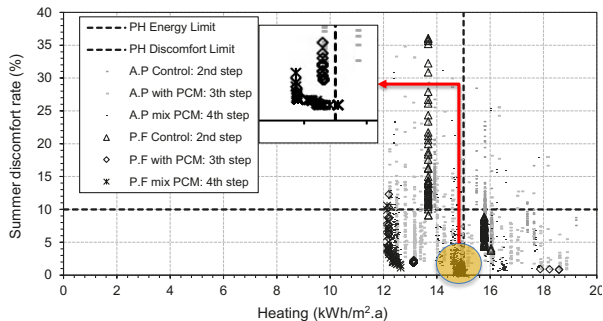

Fig. 5: Optimized results: 4<sup>th</sup> step.

The use of PCM solutions with different melting points resulted in an improvement in the thermal comfort during the summer season. A reduction of 57% of the discomfort rate was achieved compared to the model with the lowest discomfort rate (0.82% of discomfort rate) from the optimization with PCM solutions with the model that uses a mixed PCM solution (0.35% of discomfort rate).

The optimized solution attained combines the bypass air flow rate of  $2.44 \text{ h}^{-1}$  with a temperature activation of  $20 \text{ } ^{\circ}\text{C}$  using windows with  $U_{\text{value}} = 0.70 \text{ (W}/(\text{m}^2 \text{ } ^{\circ}\text{C}))$  and  $\text{SHGC} = 0.53$  north orientated and  $U_{\text{value}} = 0.65 \text{ (W}/(\text{m}^2 \text{ } ^{\circ}\text{C}))$  and  $\text{SHGC} = 0.61$  south orientated. This solution was combined with 62% of BioPCM type M91 with a melting point of  $23 \text{ } ^{\circ}\text{C}$  and 38% of BioPCM type M91 with a melting point of  $21 \text{ } ^{\circ}\text{C}$ .

## 6 FINAL REMARKS AND CONCLUSIONS

This study has tackled the overheating reduction issue in low thermal inertia buildings. Different PCM solutions were applied and optimized in the internal partitions and ceiling in the compartments with south orientation.

The main conclusions that can be taken are:

- (i) From the work developed, PCM provides a favourable thermal regulation effect with a high reduction in the thermal indoor discomfort rate;

- (ii) The selection of the melting point of the PCM is crucial to fully take advantage of the PCM (charging and discharging process on a daily cycle);
- (iii) Combining different solutions of PCM with different melting points is advisable since it increases the potential for overheating reduction. The annual overall thermal comfort is improved and cooling energy demand is reduced;
- (iv) The ventilation rate is essential to assure the discharging process of the PCM. The charging and discharging processes are only possible due to an effective combination of the PCM melting temperature selection and optimized ventilation rate.

## 7 REFERENCES

1. Eurostat, *Energy statistics – residential consumption*. Eurostat. European commission. Available at: <http://epp.eurostat.ec.europa.eu/> (2011).
2. Balaras, C.A., et al., *Solar air conditioning in Europe—an overview*. Renewable and Sustainable Energy Reviews, 2007. **11**(2): p. 299-314.
3. Pacheco-Torgal, F., *Eco-efficient construction and building materials research under the EU Framework Programme Horizon 2020*. Construction and Building Materials, 2014. **51**(0): p. 151-162.
4. Santamouris, M. and D. Kolokotsa, *Passive cooling dissipation techniques for buildings and other structures: The state of the art*. Energy and Buildings, 2013. **57**(0): p. 74-94.
5. Hughes, B.R., H.N. Chaudhry, and S.A. Ghani, *A review of sustainable cooling technologies in buildings*. Renewable and Sustainable Energy Reviews, 2011. **15**(6): p. 3112-3120.

6. Florides, G.A., et al., *Review of solar and low energy cooling technologies for buildings*. Renewable and Sustainable Energy Reviews, 2002. **6**(6): p. 557-572.
7. Pomianowski, M., P. Heiselberg, and Y. Zhang, *Review of thermal energy storage technologies based on PCM application in buildings*. Energy and Buildings, 2013. **67**(0): p. 56-69.
8. 15251:2007-08, C.-C.E.D.N.E., *Indoor environmental input parameters for design and assessment of energy performance of buildings addressing indoor air quality, thermal environment, lighting and acoustics*. CEN, Brussels, Belgium. August 2007.
9. *Product Overview. Polymer Dispersions, Powders and Additives for Sealants, Flooring Adhesives and New Building Materials*. Available from: <http://product-finder.basf.com/group/corporate/product-finder/en/literature-document:/Brand+Micronal+PCM-Brochure--Product+Overview+Polymer+Dispersions+Powders+and+Additives+for+Sealants+Flooring+Adhesives+and+New+Building+Materials-English.pdf>.
10. BioPCmat. [ Consulted at November 2015; Available from: <http://www.phasechange.com/biopcmat/>.

Zurich, June 15-17 2016

Sustainable Built Environment (SBE) Regional Conference

## Expanding Boundaries: Systems Thinking for the Built Environment



### MODEL PREDICTIVE CONTROL FOR GEOTHERMAL BOREHOLE DEPTH DETERMINATION

Hongshan Guo<sup>1</sup>, Forrest Meggers<sup>1</sup><sup>1</sup> School of Architecture, Princeton University, Princeton, USA 08544

\*Corresponding author; e-mail: hongshan@princeton.edu

#### Abstract

Ground-source heat pumps provide stable and reliable heating and cooling when designed properly. The confounding effect of the borehole depth for a GSHP system, however, is rarely taken into account for any optimization: the determination of the borehole depth usually comes prior to the selection of corresponding system components and thereafter any optimization of the GSHP system. The depth of the borehole is important to any GSHP system because the shallower the borehole, the larger the fluctuation of temperature of the near-borehole soil temperature. This could lead to fluctuations of the coefficient of performance (COP) for the GSHP system in the long term when the heating/cooling demand is large. Yet the deeper the boreholes are drilled, the more the drilling cost and the operational expenses for the circulation. A controller that reads different building load profiles, optimizing for the smallest costs and temperature fluctuation at the borehole wall, eventually providing borehole depth as the output is developed. Aside from a few scenarios of different weighting factors, the resulting system costs from a MPC for optimizing the borehole depth was verified to maintain the temperature fluctuation at the borehole wall within acceptable ranges also for lengthened scale of time, indicating that the MPC is adequate to optimize for the investment as well as the system performance for various outputs.

#### Keywords:

Model Predictive Control; GSHP; borehole drilling

### 1 INTRODUCTION

The depths a geothermal well has to reach to achieve relatively steady temperature is considered to be roughly 3 to 5 feet [1]. It is also understood by expert drillers and designers that heat stored in the ground is depleted if the borehole is too shallow [2]. Yet drilling deeper costs money, which mounts up to a significant number for many considering home improvement [3]. Therefore, designers for geothermal boreholes often need to estimate the best depth for a borehole for a given building [4]. Despite Eskilson's analysis that the axial effect of boreholes becomes significant after a given time period, there is very little optimization that can be done for this process [5]. The existing studies focused either on optimizing an existing system of its heat transfer within boreholes [6], optimizing an arrangement of boreholes [7], or doing the entire optimization process in TRNSYS with

predefined system components [8]. This lack of optimization of design for GSHP could be attributed to the complexity of the nonlinear nature of GSHP and the multiple components in, and can be added to them. Some simulation and optimization of GSHP was founding the work of Alavy et al. [9] and Spitler et al. [10], where the seasonal effect of the boreholes are assessed for a borehole design of the components involved in the system, yet again, the depth of the boreholes was not considered as an optimizable component.

Encouraged by such caveat, this paper sets out to investigate the optimization of borehole depths respect to building load and costs involved. The constructed model is inspired mainly a modelling method review by Monzo [11], as well as a few other studies where the seasonal effect of boreholes is abstracted and computed to obtain maximum performance [12]. In this paper, the

constructing a control problem using a conventional optimized control approach and a model predictive control approach. The outputs from both models are analysed and evaluated to be determine their feasibility and used to assess their potential of being used to assist GSHP design.

## 2 SYSTEM BASICS

### 2.1 Axial effects for borehole design

The change in temperature at a given location and time due to the effect of a point source releasing  $q'$  units of heat per second was defined as:

$$\Delta T(r, t) = \frac{q'}{4\pi k_s r} \operatorname{erfc}\left(\frac{r}{2\sqrt{\alpha t}}\right) \quad (1)$$

where  $q'=q/H$  and  $q$  is the rate of heat transfer into or away from the ground(W),  $k_s$  is the borehole thermal conductivity (W/mK), and  $\alpha$  is the thermal diffusivity of the ground. Another equation used to assess the impact of the injection with respect to the different depths of the system is

$$\Delta T(r, t, z, H) = \frac{q'}{4\pi k_s H} \left( \frac{\operatorname{erfc}\left(\frac{d(u)}{2\sqrt{\alpha t}}\right)}{d(u)} - \frac{\operatorname{erfc}\left(\frac{d'(u)}{2\sqrt{\alpha t}}\right)}{d'(u)} \right) \quad (2)$$

in which  $d(u) = \sqrt{r^2 + (z - u)^2}$  and  $d'(u) = \sqrt{r^2 + (z + u)^2}$ , with  $z$  being the elevation of the point where the computation is completed. To perform the OCP construction for dynamic optimization, an alternative form of Equation (1) is identified where the exponential integral is simplified for computational purposes:

$$\Delta T(r, t) = \frac{q'}{4\pi k_s H} \left( \ln \frac{4\alpha t}{r^2} - \lambda \right) \quad (3)$$

where  $\lambda$  is Euler's constant = 0.5772. For the benefit of computing, the outputted average temperature difference along the borehole wall from Equation (3) is selected to be the appropriate component to be included in the optimized control problem design.

### 2.2 Building load

To better assess the preferred borehole depths throughout an entire year, a synthetic building load profile is selected as in Equation (4):

$$Q(t) = A - B \cos\left(\frac{t}{8760} 2\pi\right) - C \cos\left(\frac{t}{24} 2\pi\right) - D \cos\left(\frac{t}{24} 2\pi\right) \cos\left(\frac{2t}{8760} 2\pi\right) \quad (4)$$

As was described by Marcotte et al. [9], a scenario with  $A = -30$ ,  $B=100$ ,  $C= 50$ ,  $D = 24$  is selected in accordance with the heating-dominated climate profile of Princeton where this study is conducted.

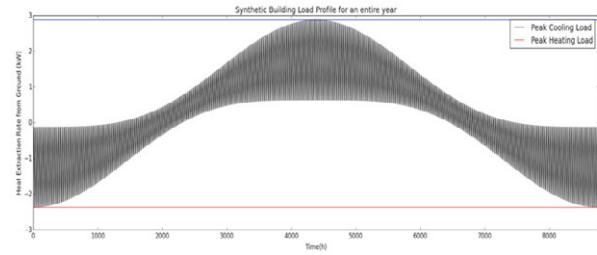

Fig. 1: Synthetic Building Load Profile.

Evaluating the load profile on a yearly basis for the different depths was used with the  $\Delta T$  function, the trade-off between the different borehole depths and the fluctuation of temperature in the boreholes.

Pronounced fluctuations in the range between 0 and 50 meters of depth should be avoided for houses that are interested in geothermal systems since this could indicate inadequate system performance. But other factors, including the drilling and electricity cost has to be taken into account to optimize for a desirable design.

### 2.3 First and Electricity Cost

More than 80% of the first cost of geothermal system went to drilling costs [13], many companies even gave quotes of systems based only on the depths of the boreholes. A simplification is therefore necessary as described by Rafferty [14], that the cost of wells that aren't deeper than 500ft has a hard drill cost of 5\$ per feet borehole per inch diameter. For a borehole with 0.075 m radius (common according to Monteyne et al., that is 48.425 dollar per meter for the drilling [15].

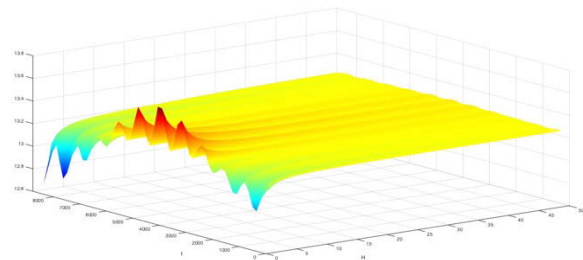

Fig. 2: Synthetic load profile for the building for 8760 hours applied with a depths profile from 0 to 50 meters.

The electricity cost of the system is split into the power consumption of the heat pump, which is related with the building load as  $P_{hp} = \frac{Q_{building}}{COP}$ , in which COP is a variable that with respect to the inlet water temperature of the heat pump and have heating and cooling modes. Also included is the pumping costs that is a variable of the depth of borehole, as can be obtained from the pumping power equation as  $P_{electricity} = \frac{\dot{m} \rho g h}{3.6 \times 10^6}$ , in which  $\dot{m}$  is the flow capacity is in  $m^3/h$  while  $\rho$  is the density of

$P_{electricity} = \frac{\dot{m}\rho gh}{3.6 \times 10^6}$ , in which  $\dot{m}$  is the flow capacity is in  $m^3/h$  while  $\rho$  is the density of circulating fluid and  $g$  is the gravitational constant at  $9.81 m/s$ .

### 3 CONTROL PROBLEM FORMULATION

#### 3.1 Modified Cost function

The aim is to optimize the borehole depth such that both the monetary cost and ground temperature stabilization can be achieved at the same time. As those two are conflicting objectives, a multi-objective approach is put forward. The cost function, presented by Equation (5) is a weighted sum of the drilling cost  $J_d$ , electricity cost  $J_c$  and the thermal fluctuation cost  $J_T$ , evaluated over a time period of  $[0, t_{eval}]$ , which is take as an entire year for this control problem formulation.

$$J_{tot} = (1 - K) \left( \int_0^{t_{eval}} J_c dt + J_d \right) + K \int_0^{t_{eval}} J_T dt \quad (5)$$

For  $K = 1$ , the optimal control profile minimizes the temperature fluctuation and assumed no consideration for the cost is needed, while for  $K = 0$ , the optimal control profile maximizes the economic investment required for the system while ignoring the possible decrease of geothermal potential.  $J_T = \Delta T^2$  represents the squared temperature penalty, while similarly  $J_e = c_{el}(P_{hp}(t) + P_{cl})$ , and the expression  $J_d$  represents the cost resulting from the drilling.

Model Predictive Control is known as a class of computer algorithms that predicts future system behaviour while computing the correct control actions required to drive the predicted output towards the desired output. Therefore, to modify the existing controller to form an MPC problem the cost function will first have to be modified into a multivariable control algorithm. This requires an internal dynamic model of the process, a history of past control moves, and an optimization cost function over the receding prediction horizon in order to calculate the optimum control move [13]. This, combined with the aim of this study, provide us the following modified cost function:

$$J_T = \Delta T(t, H, r, Q_b) + \sum_{i=1}^{t-1} \Delta T(i, H, r, Q_b(i-1)) \quad (6)$$

#### 3.2 Controller Model

The system dynamics are defined by a set of ordinary differential equations. They correspond to a simplified setup of a geothermal water-to-water system of a varied depth profile:

$$\dot{Q}_b = \frac{25}{6} \pi \sin\left(\frac{\pi t}{12}\right) + \frac{5}{219} \pi \sin\left(\frac{\pi t}{4380}\right) + \frac{25}{12} \pi \sin\left(\frac{\pi t}{12}\right) \cos\left(\frac{\pi t}{2190}\right) + \frac{5}{438} \pi \sin\left(\frac{\pi t}{2190}\right) \cos\left(\frac{\pi t}{12}\right) \quad (7)$$

$$P_{hp} = \frac{\dot{Q}_b}{COP} \quad (8)$$

$$\Delta T(r, t) = \frac{\dot{Q}_b}{4\pi k_s H} \left( \ln \frac{4\alpha t}{r^2} - \lambda \right) - \frac{\dot{Q}_b}{4\pi k_s H} \left( \frac{r^2}{4\alpha t} \right) \quad (9)$$

$$C_i \dot{T}_i = \dot{m}(T_r - T_i) + \dot{Q}_b \quad (10)$$

In the dynamic equations, the terms are correspondingly representing  $Q_b$  building load(kW),  $P_{hp}$  as the power consumption of the heat pump,  $COP$  as the coefficient of performance,  $T_i$  as the incoming water temperature for the GSHP in  $^\circ C$ , and  $C_i$  represented the thermal capacity of the water (J/K). In this formulation the control variable is the depth of the borehole  $H$ . Modulating  $H$  with respect to the cost function will allow for the minimum amount of economic input and the least depletion of the geothermal resources, or more specifically in the form of the following equations:

$$J_d = 48.425H \quad (11)$$

$$P_{cl} = 0.266 \frac{kg}{s} \times 3600 \frac{kg}{h} \times 1000 \frac{kg}{m^3} \times 9.81 \frac{m^2}{s} \times H = 2.609H \quad (12)$$

$$COP_{heating} = \frac{T_i}{T_i - T_r} \quad (13)$$

$$COP_{cooling} = \frac{T_r}{T_r - T_i}$$

#### 3.3 Solving with Initial, Boundary Condition and temperature constraints

Corresponding to the dynamic ODEs, the model states are respectively  $S = [Q_b, P_{hp}, COP, T_i]$ . While the other three parameters are all bounded to  $T_i$  with it being the water supplied by the ground, it is determined that it should be a bounded value between  $t_0$  and  $t_{eval}$  since the optimization process was for an entire year, such that  $T_i(t_0) = T_i(t_{end})$ . The upper and lower bounds of the inlet temperature are determined according to empirical values as  $37^\circ C$  and  $7.2^\circ C$  as according to [2]. The continuous optimal control problem has to be discretized for a direct numerical solver. The control variable is discretized using a piece-wise constant function, such that during one discretization time step  $H$  is constant. The smaller the discretization time step, the smaller the difference between the continuous and discretized optimal control profiles, the longer the computation time.

The formulations discussed adopted a discretization time step of one hour, yielding a total 8670 control variables to be optimized. The Automatic Control and Dynamic Optimization toolkit ACADO is used for this study to discretize the OCP with multiple shooting methods developed by Bock and Plitt: state variables are discretized at a different time step than the control variables to minimize the discretization error, for which a standard Runge-Kutta 45 integrator was used. The resulting discrete-time optimization problem is solved with the following trajectory:

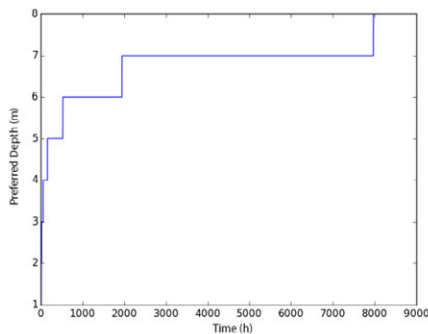

Fig. 3: Trajectory of obtaining preferred depth for heating-dominated season.

### 3.4 Solving with Initial, Boundary Condition and temperature constraints

In lack of a better solver, the MPC problem was constructed in Python where the search of minimized cost function was dealt with nested for loops. The initial condition for each time step is initialized for every one of the 8760 iterations. The for loops also made it possible for the temperature penalty to be carried on for the next time step - that is, an increment of  $t = 1$  in the Python function. The resulting temperature fluctuation at the borehole can be found in Fig.4 as the followings: The output is a borehole depth of 1 meters of an equal weighting between the cost and the temperature penalty for this simulation. Correspondingly, the overall system cost for a year was found to be \$8397.96 with a temperature penalty of  $-0.41$  °C, this is consistent with the findings from Garber et al. where the operational costs were at the same order of magnitude [16].

### 3.5 Performance Evaluation

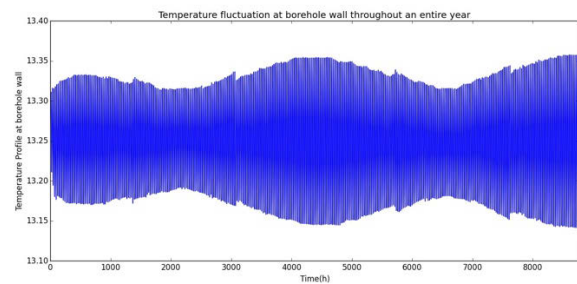

Fig. 4: Trajectory of the temperature profile at borehole wall during year-long simulation.

Various weighting factors  $K$  (0.1-0.9) were used to assess the relationship between the objectives shown in the following Fig. 5. The two plateaus that can be observed in Fig. 5 are in fact compensated by the increased fluctuation at borehole wall level.

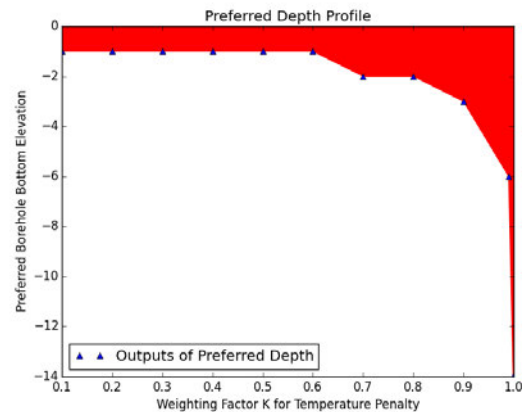

Fig. 5: Preferred variation of depths with respect to different weighting factor.

The average temperature drop at borehole walls can also be obtained in the following Fig. 6 as well as the resulted cost in Fig. 7.

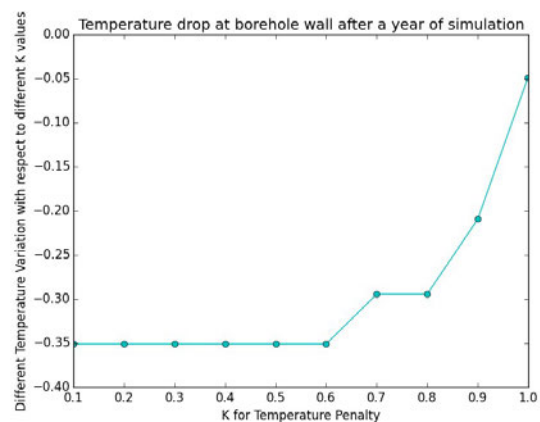

Fig. 6: Mean temperature variation at borehole walls at end of each simulation year for different weighting factor  $K$ .



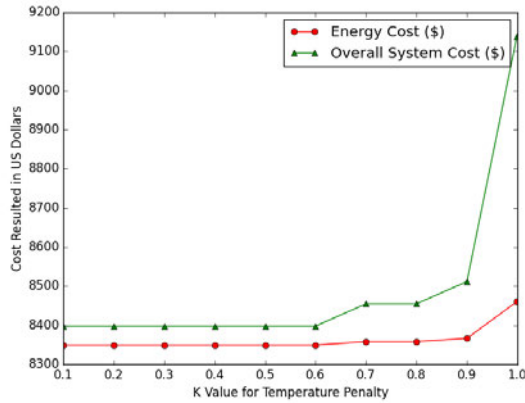

Fig. 7: Resulting costs (in US\$) variation resulting from different weighting factors.

### 3.6 Expanding the time frame

The performance of the controller is further tested by expanding the time frame of simulation where the resulting temperature fluctuation throughout simulation can be seen in the following plots:

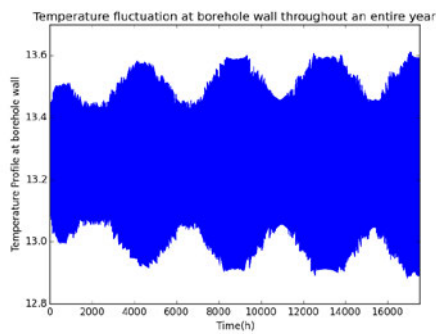

Fig. 8: Temperature fluctuations at borehole walls from a 2-year simulation.

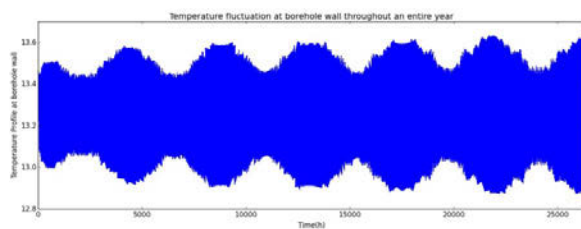

Fig. 9: Temperature fluctuations at borehole walls from a 3-year simulation.

## 4 CONCLUSION AND DISCUSSIONS

The possibility to develop an easily accessible optimization tool for a given building profile was investigated in this paper. Both the dynamic optimal system control problem and the model predictive control methods were used to seek the optimal borehole depth. Model predictive control was determined to be more adequate in that it allows the temperature penalty to be carried from one-time step to another.

It is believed that this MPC-based optimal design estimator should be able to help geothermal system designers to make quick and efficient decisions for different kinds of climate and load profile. Since the MPC controller was built in Python, it is easily convertible to a weather-file based borehole depth design optimizer. It can include variables such as the electricity and weighting factors that are easily adjustable. Although from the results of this paper it is advised that any subjective weighting aim for deeper for the benefit of long-term system performance.

Further research could be focused on introducing more drastically different load profiles, and include increased control logic to introduce further components - solar-hybrid system or thermal storage system, to be optimized for preferred borehole depth, etc. Lengthening the simulated time period could also be feasible to more appropriately examine the costs since the resulting effect of temperature variation will further lead to further changes in the heat pump performance.

## 5 REFERENCES

1. Sanchez, J. A. (2014, January 4). ENHANCING THE QUALITY OF GROUND COUPLED HEAT PUMPS.
2. Self, S. J., Reddy, B. V., & Rosen, M. A. (2013). Geothermal heat pump systems: Status review and comparison with other heating options. *Applied Energy*, 101(C), 341–348.
3. KIPSANG, C. (2014). Cost Model for Geothermal Wells, 1–12.
4. Philippe, M., bernier, M., & Marchio, D. (2010). Sizing Calculation Spreadsheet for VerticalGeothermalBorefields, 1–10.
5. Eskilson, P. (1989). Thermal Analysis of Heat Extraction Boreholes, 1–222.
6. Monteyne, G., Javed, S., & Vandersteen, G. (2014a). Heat transfer in a borehole heat exchanger: Frequency domain modeling. *Heat and Mass Transfer*, 69(C), 129–139.
7. Bayer, P., de Paly, M., & Beck, M. (2014). Strategic optimization of borehole heat exchanger field for seasonal geothermal heating and cooling. *Applied Energy*, 136(C), 445–453.
8. Pärtsch, P., Mercker, O., Oberdorfer, P., Bertram, E., Tepe, R., & Rockendorf, G. (2015). Short-term experiments with borehole heat exchangers and model validation in TRNSYS. *Renewable Energy*, 74(C), 471–477.
9. Alavy, M., Nguyen, H. V., Leong, W. H., & Dworkin, S. B. (2013). A methodology and computerized approach for optimizing hybrid

ground source heat pump system design. *Renewable Energy*, 57(C), 404–412.

10. Spitler, J. D., Liu, X., Rees, S. J., & Yavuzturk, C. (2005, April). SIMULATION AND OPTIMIZATION OF GROUND SOURCE HEAT PUMP SYSTEMS.

11. Monzo, P. (2015). Comparison of different Line Source Model approaches for analysis of Thermal Response Test in a U-pipe Borehole Heat Exchanger.

12. Marcotte, D., Pasquier, P., Sheriff, F., & Bernier, M. (2010). The importance of axial effects for borehole design of geothermal heat-pump systems. *Renewable Energy*, 35(4), 763–770.

13. Miyora, T. O. (2014). MODELLING AND OPTIMIZATION OF GEOTHERMAL DRILLING PARAMETERS - A CASE STUDY OF WELL MW-17IN MENENGAI, KENYA, 1–75.

14. Rafferty, K. (2002). A Spreadsheet for Geothermal Direct Use Cost Evaluation, 1–14.

15. VERHELST, C. (2015). Model Predictive Control of Ground Coupled Heat Pump Systems for Office Buildings, 1–316.

16. Garber, D., Choudhary, R., & Soga, K. (2013). Risk based lifetime costs assessment of a ground source heat pump (GSHP) system design: Methodology and case study. *Building and Environment*, 60(C), 66–80.



## Expanding Boundaries: Systems Thinking for the Built Environment

### INTEGRATING PERSUASIVE TECHNOLOGY IN PROTOTYPES OF INTERIOR WALLS TO STIMULATE BEHAVIOURAL CHANGE

M. Mohammadi<sup>1,2</sup>, C. Hammink<sup>2\*</sup>, M. Dominicus<sup>1</sup>, K. Hermans<sup>1,2</sup>

<sup>1</sup>Faculty of the Built Environment, Eindhoven University of Technology, De Wielen 1, 5612 AZ Eindhoven, The Netherlands.

<sup>2</sup>Research Group Architecture in Health, HAN University of Applied Sciences, Ruitenberglaan 26, 6826 CC Arnhem, The Netherlands

\*Corresponding author; e-mail: coosje.hammink@han.nl

#### Abstract

Sustainability has gained influence and importance in the building industry since the 1960s. Originally, sustainable materials and energy reduction have been in the spotlight, but recently other aspects have become more influential as well, such as trying to influence people's behaviour. This paper explores the possibility of influencing behaviour through the use of the Built Environment. Due to the fact that people spend 87% of their time indoors, the adaptation of buildings presents an opportunity to contribute to decreasing energy and resource consumption through behaviour change. One way of accomplishing this is persuasive technology, since its definition contains any interactive system designed to change people's attitudes or behaviours. However, at present, most of the applications of this technology can be found in the fields of industrial design and computer sciences. Hardly any literature specifically deals with the incorporation of technology aimed to persuade humans through the use of buildings or building elements. Nonetheless, the technology identified in literature can be applied to the built environment. To integrate this persuading technology in the built environment, we have chosen to develop a prototype of an interior wall meant to stimulate behaviour change. In this research paper we will explain this prototype in further detail. In the discussion, this article will evaluate feedback and suggest areas for future investigation. Furthermore, implications of these prototypes of interior walls to stimulate behaviour change in the design process will be elaborated upon. Lastly, due to the limited knowledge on this subject, this article serves as a foundation for future development of other persuasive (prefab) building elements.

**Keywords:** persuasive technology; prototypes; product development; built environment; behaviour change

#### 1 INTRODUCTION

Ever since the influential Brundtland [1] report, the attention for sustainability has risen tremendously. At first, research focused mainly on ecological and economic sustainability. However, lately the behavioural aspect of sustainability has received more attention as well [2]. To balance the ecological, economic and social side of sustainability, a new paradigm within sustainability has arisen, in which smart technology is used to stimulate people to display

pro-environmental behaviour. This persuasive technology differs from 'regular' technology in that it not only supports people's daily activities, but also seeks to influence human behaviour and/or attitudes [3][4].

The majority of applications is found in the fields of Health and Medicine, Engineering, Industrial Design and Computer science [5]. Surprisingly, principles and concepts used in persuasive technology have not yet found their way into the construction and design of buildings, even though

we spend most of our time indoors (87%) [6]. Within literature and research on the built environment and sustainability, the focus is still primarily on the technical improvements for sustainability [7]. In order to promote sustainability in the living environment, not only technical solutions should be sought after, but behaviour change should also be pursued and building occupants should be included. To achieve this a balance between personal characteristics and environmental characteristics should be found [8]. Current research states that behaviour is the outcome of the person-environment relationship [8] [9]. Technology can be used to bridge the gap between the occupants and their environment and can be used to facilitate (behavioural) changes in social, ecological and economical areas. This paper serves to give an insight into the overlap between people, the environment and technology (see Fig. 1).

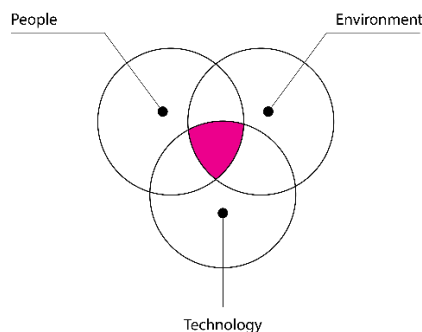

Fig. 1: PET Model.

First, this paper will discuss the (built) environment, (behaviour change in) people and (smart) technology. Secondly, literature and references projects on where these fields (partially) overlap are discussed. In the third step, one experimental prototype that fit into the overlapping area is presented. Lastly, implications for the design process in the built environment are discussed.

### 1.1 (Built) Environment

Einstein once remarked, "the environment is everything that is not me" [9]. The environment is a complex, multi-dimensional and multi layered system [10] [11]. Social ecological models are used to unravel the multidimensional structure of human environments and will be used as a framework within this research [12]. Human behaviour within a specific environment has been studied from a social, psychological and cultural context [12]. The outcome of the relations between these three different environments can be seen as behaviour (see image 2). The WHO defines environment as all the physical, chemical and biological factors external to a person, and all the related behaviours [11]. In this paper we will examine the use of the environment as an instrument for behaviour change. Moffatt & Kohler [12] divide the environment into a natural

environment and a cultural environment (Fig 2). The overlapping area between these two environments can be described as the man-made environment or, as we use it in this paper, the built environment. The built environment consists of 5 layers, of which the layer 'building-level' can be subdivided into six layers [13].

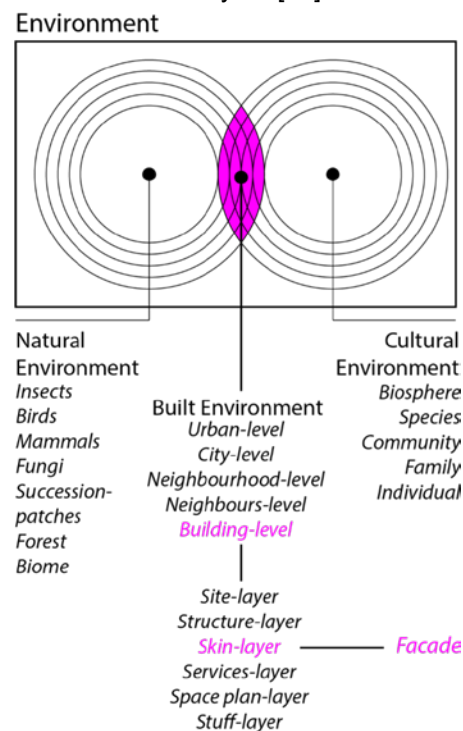

Fig. 2: Research Focus [13] [14].

### 1.2 Behaviour change (People)

Behavioural change is a field of research that has received ample attention in a number of fields, whether it is in criminology, psychology or, more recently, design research, people seek to influence their own, or other people's behaviour. People may seek to change their own behaviour, such as eating healthier or saving money, but there is also a need for behavioural change from a societal point of view. Many of the challenges today's society faces, can be mitigated by behaviour change [15] [16] [17] [18].

### 1.3 Ambient Technology

Incorporation of a certain degree of intelligence in the built environment has been introduced in the previous century. Domestic technology was the first trend in which digital tools were applied in order to achieve comfort and security for the user [19]. This technology has seen an expansion into the domain of ambient technology, in which the degree of comfort and security can be (automatically) adjusted to the current demands and wishes of the user. For example, ambient technology is capable of analysing the residence, and based on this information can adjust the climate accordingly. Ambient or smart technology is different from persuasive technology in that the goal of the latter is to change behaviour, whereas in ambient technology, this is not necessarily the

case. However, ambient technology does offer an insight in how technology can be implemented in the built environment.

## 2 USING (BUILDING) DESIGN TO CHANGE BEHAVIOUR

Little to no research is available on integration of products that can modify behaviour into buildings. However, literature on persuasive and ambient technology can be used to gain insights into the technological possibilities and underlying frameworks to stimulate pro-environmental behaviour change using the built environment, or more specifically building interior walls. In paragraph 2.1 and 2.2 we examine the literature on respectively persuasive ambient technology and operant conditioning in order to derive conditions for our own persuasive building (element) design. In 2.3 we will examine the application of these conditions in interior walls.

### 2.1 Ambient Technology

Ambient technology creates an electronic environment that is sensitive and can react to the presence of people [20]. This aspect of ambient technology can be employed to stimulate behavioural change. Ambient technology is embedded in the environment and would ideally be adaptive to a person's specific wants and needs [21]. These environments provide the possibility to stimulate occupant to display more sustainable behaviour. The literature on ambient technology uses an amalgamation of different behavioural theories and knowledge on source credibility, multiple sources, attitude and behaviour formation, information processing, mental shortcuts and sustaining behaviour [21]. For each of these clusters, persuasion principles have been identified, which can be used in designing ambient technology for behavioural change [20].

### 2.2 Operant Conditioning

One of the persuasion principles used in literature on ambient technology is the use of feedback (to sustain behaviour) [20]. For the development of this building product, we have used a classical form of feedback: operant conditioning. When using operant conditioning, feedback can be given in four ways: (i) positive reinforcement (ii) negative reinforcement (iii) presentation punishment and (iv) removal punishment [22]. For this product we chose to explore the possibilities for negative feedback, or '(presentation) punishment'. Research shows that there are many examples of the effectiveness of enforcing rather than encouraging behaviour. However, most persuasive technology at this time is based on the latter, whereas with this product we explore the possibilities for 'punishment' as feedback. In this case we use presentation punishment as we are approaching energy (over-)consumption as a behaviour we

want to decrease or suppress. Research found that when trying to diminish certain behaviour, people are more likely to do so if they believe they are going to be punished rather than being offered rewards [23].

After selecting the type of feedback, the reinforcement schedule can be examined. This product uses a continuous scheme; allowing for rapid learning, but not as effective in creating long-term habits [22]. In order for the appropriate response to take place, 'cueing' is used, in terms of using lighting and colours to indicate the type of response needed (e.g. reduce energy use) [22].

### 2.3 Application of Ambient Technology in Interior walls

Several elements of the behaviour changing process are discussed in literature on ambient technology [21] and different types of feedback and feedback schemes have been derived from literature on operant conditioning [22]. The next chapter will go into the details of the product design and will explain how the conditions identified in literature on operant conditioning and ambient technology can be used in the design process for persuasive building interior walls.

## 3 TRANSLATING THEORY INTO PRODUCTS

Innovation can be described as the creation of a new or improved product, service, or process [24]. The OECD defines innovation from a broader perspective; "Innovation is an iterative process initiated by the perception of a new market and/or new service opportunity for a technology-based invention which leads to development, production and marketing tasks, striving for the commercial success of the invention". This iterative process is capable of influencing human behaviour [25] [26]. Therefore, we can describe (building) product development as a driver for behaviour change. In line with the OECD, we can define product development ('New Product Development') as a process of developing a design for a new product, including all the relevant plans for production, distribution, and sales [27]. The foundation of successful product development is using participatory and empirical research. In this model the user is a part of the total design process, by engaging these users in the design process, the behaviour change indicators can be determined [27]. In literature we can distinguish several product development models [28]. Most of the models subdivide the design process into multiple phases, which lead to a more controlled end product and controlled behaviour change [28] [29]. It concerns developing a normative model consisting of 7 stages, in which every stage includes a number of activities; (i) idea, (ii) preliminary assessment, (iii) concept, (iv) development, (v) testing, (vi) trial and (vii)

launching. These seven stages of Cooper are corresponding with the six stages of Ulrich and Eppinger [30], and Roozenburg [27]. These authors distinguish the following stages; (i) concept development, (ii) system level design, (iii) detail design, (iv) testing and refinement and (v) production (ramp up). In this research we combined the models of Cooper, Ulrich and Roozenburg, to get a new model, in which the cycles of empirical scientific inquiry are used to influence the level of persuasion (see Fig.3).

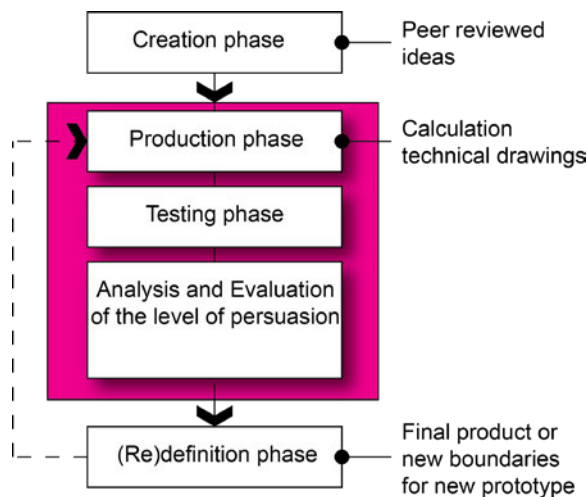

Fig. 3: Product Development Model.

#### 4 PRODUCT DEVELOPMENT OF PERSUASIVE WALL SYSTEM

In this paragraph we will go into our design in which we will experiment with the level of persuasion by developing a persuasive building wall system. Several ideas are generated by a team of experts in the field of architecture and design and are peer reviewed by another team of experts. The developed product, the 'white box', is a combination of three interactive interior walls. The white box aims to persuade occupants to exhibit more green behaviour. It aims to make occupants aware of energy use, by using operant conditioning (feedback). If the energy use in the white box is too high, the white box interacts with the occupant by using presentation punishment [22]. This interaction is manifested by changing the amount of cubic meters of the space in the white box, by decreasing the height of the ceiling and by using round objects, which are pulled and pushed through the walls with a certain frequency. This is made possible by using flexible double membranes made of high elastic fabric and by allowing space between two membranes with a wooden scissor structure (figure 4 and 5).

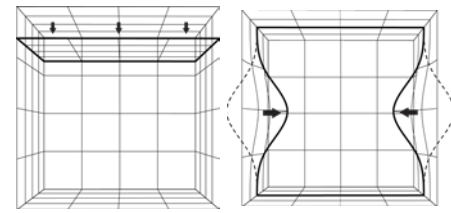

Fig. 4: Actions of the White Box.

The expansion of the scissor structure is possible through a solid wooden construction. This wooden construction is a framework, which is necessary for the internal and external stability (see fig 5, 6).

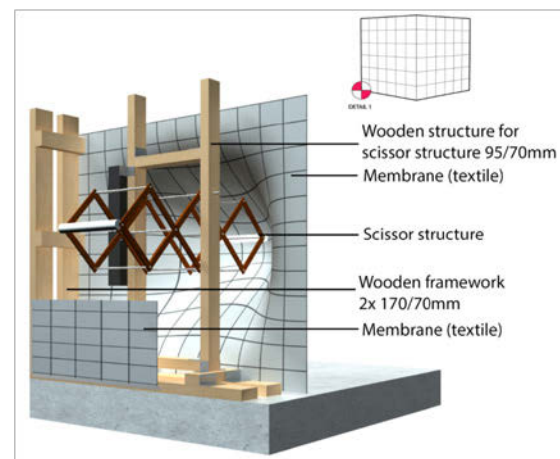

Fig 5: Technical detail White box.

The objects, which are pulsating and pushing on the membrane, react to the level of energy use. If the energy use is too high, the round objects will begin to pulsate. The pulsating objects are built based on scissor structures, which are able to expand and to fold back. A round polystyrene shape is fixed at the end of the scissor structure, which is causing a smooth, curved membrane when the scissor structure is expanded.

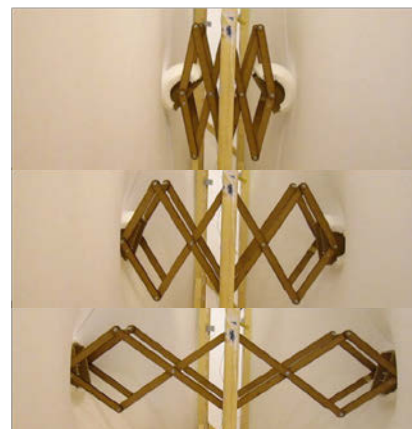

Fig. 6: Expansion of the scissor structure.

The movement of the scissor structure is possible through the use of an Arduino controlled motor, which allows the white box to increase or decrease the speed of expansion (fig. 6 and 7).



Fig. 7: Pulsating objects in the walls of the white box.

To examine the potential of this product, a variant of the white box has been implemented in an existing building. This variant, the so-called 'breathing wall', has been placed into a room of a hotel (Motel Spatie, Arnhem). A fully covered space with a flexible membrane such as PVC or Lycra, is not suitable everywhere. Therefore, the walls of the white box were further developed into single wall elements. The single wall element has the same characteristics as the wall of the white box, except it has more feedback options such as led lights. These led lights can be red or green depending on the energy use; furthermore, the wall will pulsate using the scissor structure (see fig. 8). The user has to take action in order to return the wall to a 'silent mode'. The hope is that these actions will stimulate the user to be more aware of the use of energy.

The feedback system of the breathing wall and the white box can be interpreted as a form of presentation punishment, where the occurrence of the feedback is supposed to diminish or suppress the behaviour [22].

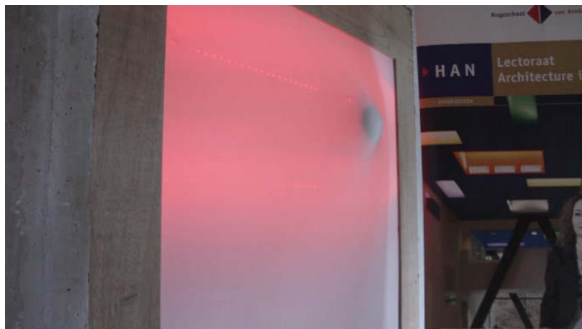

Fig. 8: Breathing wall.

The breathing wall operates using continuous feedback, which means that every response is reinforced. In order to achieve the iterations and input of users, the white box was displayed at the Dutch Design Week 2014. Visitors could use the white box and gave information on how to improve this prototype. The reaction of these visitors was divers, some felt uncomfortable, others felt surprised or found it interesting. Visitors that gave positive responses to the persuasive wall indicated that they felt it was the right interface for this type of information and was unambiguous in its message. Visitors that

felt less comfortable with the product doubted the effectiveness of the product for changing long-term behaviour (habit forming). Both groups raised the matter of ethics in the further development of the product.

## 5 CONCLUSION & DISCUSSION

At the moment hardly any literature on the use of persuasive technology in buildings or building elements exists. The current literature on behaviour change products is focused primarily on stand-alone products, which are not part of a larger, embedded system (like a building). This research attempts to start with the creation of a framework for integrating persuasive technology in the built environment. This has led to the development of two products: the white box and the breathing wall. In the development of these building interior walls technological and social challenges were encountered. The first challenge lies in the use of persuasive technology in prefab building elements. New building methods should create an integrative system, as all building elements are intertwined. Furthermore, the technical elements, such as the wiring, the controlling system and more, have to be implemented in an earlier building phase than is presently done. Current methods for using technology in the home environment, are built in afterwards and do not allow for this full integration to take place.

Besides the changes in the production, at this point in time, we don't know if the pulsating elements are indeed triggering the users to change their behaviour. Moreover, the implementation of the white box and the breathing wall can be seen as affecting the autonomy of the occupant. The research on the level persuasion can give indicators as to the effectiveness, but will also be employed in order to identify the user boundaries. Lastly, we realize that the white box and the breathing wall will in this state not be suitable for direct introduction into the market, but combining the reactions of users and the gathered data from the hotel will allow for an evaluation of the level of persuasiveness of the principles employed in these products. This will enable us to conclude if integration of these persuasive products in the built environment is a development that can contribute to behaviour change.

## 6 ACKNOWLEDGMENTS

Special thanks to R. Bakx, P. Beurskens, J. v Asten, M. Lambriex, E. Groen, N. Schuijers, M. Meijer, R. Versteeg, T. Lusing, N. Sijbers and R. v Bezooijen for their contribution to the design and development of the prototypes.

## 7 REFERENCES

1. Schubert, A., & Lang, I., The literature aftermath of the brundtland report: 'our common future': A scientometric study based on citations in science and social science journals. *Environment, Development and Sustainability*, 2005. 7(1) : p. 1-8.
2. Barr, S. *Environment and society: Sustainability, policy and the citizen*. 2008, Ashgate, Aldershot.
3. Verbeek P., Ambient intelligence and persuasive technology: The blurring boundaries between human and technology. *NanoEthics* 2009. 3(3): p. 231-242
4. Fogg B.J., *Persuasive Technology: Using Computers to Change What We Think and Do*. 2003, San Fransisco: Morgan Kaufmann Publishers.
5. IJsselsteijn, W., De Kort, Y., Midden, G., Eggen, B., & Van Den Hoven, E., Persuasive technology for human well-being: Setting the scene in *Lecture Notes in Computer Science (Including Subseries Lecture Notes in Artificial Intelligence and Lecture Notes in Bioinformatics)*. 2006 : 3962 LNCS. pp. 1-5.
6. Klepeis, N., Nelson, W.C., Ott, W.R., Robinson J.P., Tsang, A.M., Switzer, P. The National Human Activity Pattern Survey (NHAPS) A Resource for Assessing Exposure to Environmental Pollutants. 2001.
7. Psarikidou K. & Szerszynski B., Growing the social: alternative agrofood networks and social sustainability in the urban ethical foodscape. *Sustainability: Science, Practice, & Policy*, 2012. 8(1): p. 30-39.
8. Lawton, M.P. *Clinical Psychology in The psychology of adult development and aging*. Eds. Eisdorfer, C. & Lawton M.P. 1973. Washington DC: American Psychological Association.
9. Kahana, E. A. congruence model of personenvironment interaction in Aging and the environment, theoretical approaches. Eds. Lawton, P.M., Windley, P.G. & Byerts, T.O.. 1982. New York: Springer Publishing Company.
10. Singh, G. *Environmental law: international and national perspective*, 1995. New Dehli, Lawman publishers.
11. Pruss-ustin, A. & Corvalan, C. *Preventing disease through healthy environments*, 2006. Geneva: WHO.
12. Stokols, D., Lejano, R.P. & Hipp, J. *Enhancing the Resilience of HumanEnvironment Systems: a Social Ecological Perspective*. *Ecology and Society*, 2013, 18.
13. Moffatt, S. & Kohler, N. *Conceptualizing the built environment as a social-ecological system*. *Building Research & Information*, 2008, 36, p. 248-268
14. Brand, S. *How buildings learn. What happens after they're built*, 1994. Orion books ltd.
15. IPCC. *Summary for policymakers*. In C. B. Field, et al. (Eds.), *Climate change 2014: Impacts, adaptation, and vulnerability. part A: Global and sectoral aspects. contribution of working group II to the fifth assessment report of the intergovernmental panel on climate change*, 2014. Cambridge, United Kingdom and New York, NY, USA: Cambridge University Press, p. 1-32.
16. Berghöfer, A., Pischon, T., Reinhold, T., Apovian, C.M., Sharma, A.M., Willich, S.N., *Obesity prevalence from a European perspective: a systematic review* . *BMC Public Health*, 2008. 8(200).
17. World Health Organization, *World health Statistics 2010*. World Health Organization.
18. Armstrong, B., Lim, C.S., Janicke, D.M., *Park Density Impacts Weight Change in a Behavioural Intervention for Overweight Rural Youth*. *Behavioural Medicine*, 2015, 41:3, p 123-130.
19. Aldrich, F., *Smart Homes: Past, Present and Future*. In: Harper, R. (ed.) *Inside the Smart Home*, 2003, Springer-Verlag, p 17-39.
20. Kaptein, M.C., Markopoulos, P., de Ruyter, B., Aarts, E., *Persuasion in ambient intelligence*. *Journal of Ambient Intelligence and Humanized Computing*, 2010. 1(1): p. 43-56.
21. Aarts, E.H.L., Markopoulos, P., de Ruyter, B.E.R. *The persuasiveness of ambient intelligence. Security, Privacy and Trust in Modern Data Management*, 2007. In : Petkovic, M. ; Jonker, W. ed.: Springer.
22. Mazur, J.E., *Learning and behaviour (5<sup>th</sup> ed)*, 2002, Upper Saddle River, NJ, US: Prentice Hall/Pearson Education Learning and behaviour.
23. Kubanek, J., Snyder, L.H., Abrams, R.A. *Reward and punishment act as distinct factors in guiding behaviour*. *Cognition*, published online March 29, 2015
24. Veryzer, R.W. *Discontinuous Innovation and the New Product Development Process*. *Journal of Product Innovation Management*, 1998. 15,p. 304-321
25. Garcia, R., *A critical look at technological innovation typology and innovativeness terminology: a literature review*. *Journal of Product Innovation Management*, 2002. 19, p. 110-132.
26. OECD, *The nature of innovation and the evolution of the productive system*. . *Technology and productivity*, 1991. Paris: OECD



27. Roozenburg, N.F.M. & Eekels, J. Productontwerpen, structuur en methoden, 1998. Den Haag, LEMMABV.

28. Lichtenberg, J.J.N., Ontwikkelen van projectongebonden bouwproducten, in Building technology. 2002, TU Delft: Maastricht. p. 282.

29. Cooper, R.G. The strategy-performance link in product innovation. R&D management, 1984, 14, 247-259.

30. Ulrich, K. T. & Eppinger, S. D. Product Design and Development, 1995, New York, McGraw-hill





## Expanding Boundaries: Systems Thinking for the Built Environment

### TOWARD AN INTEGRATED PLATFORM FOR ENERGY EFFICIENT LIGHTING CONTROL OF NON-RESIDENTIAL BUILDINGS

A. Motamed<sup>1\*</sup>, L. Deschamps<sup>1</sup>, J.-L. Scartezzini<sup>1</sup>

<sup>1</sup>Solar Energy and Building Physics Laboratory (LESO-PB), Ecole Polytechnique  
Fédérale de Lausanne (EPFL), CH-1015 Lausanne, Switzerland

\*Corresponding author; e-mail: ali.motamed@epfl.ch

#### Abstract

Net energy import of Switzerland corresponds to about 13 BCHF (petroleum, uranium, etc.) each year. According to the energy perspective 2035 defined by Swiss Federal Office Energy, the energy import should be reduced to 7.3 BCHF. Meeting the goals defined by this perspective can be envisaged by mitigating the energy demand of buildings since the built environment consumes 40% of the total primary energy. In Switzerland; 20 % of the buildings' energy consumption is moreover related to electric lighting. Therein, integrated building automation technologies, such as automatic regulation of sun shadings and electric lighting can play an important role in reducing lighting energy demand while maintaining user comfort. For this purpose, a rapid, reliable, accurate evaluation of the lighting conditions in a building is essential. In this paper, a control platform installed in two offices of the LESO experimental building on the EPFL campus in Lausanne, Switzerland is presented. This data acquisition and actuation platform hosts two motorized sun shadings per office, a dimmable lighting system, a presence detector, energy meters, ceiling mounted luminance-meters and two novel High Dynamic Range (HDR) vision sensors. A sample controller is implemented in the platform to evaluate its robustness and performance. This platform is currently ready for integrating novel controllers for testing several energy efficient control scenarios/algorithms.

#### Keywords:

Integrated lighting control platform; visual comfort; HDR vision sensor; user centric approach; daylighting and electric lighting, energy savings

## 1 INTRODUCTION

Although a lot of building automation equipment and technologies are developed with the aim of reducing the consumption of energy, and although the application of *sustainability rating systems* (e.g. Green Star in Australia or BREEAM in UK and LEED in US) is encouraged, in practice, the contribution to the mitigation of energy demand in the residential and non-residential buildings has remained marginal [1], [2]. A couple of reasons lead to these adverse outcomes. Firstly, the designers and manufacturers of these technologies consider mostly the energy consumption in a building from an individual "component-level" viewpoint in spite of the "system-level" complexity. In other words, the integration of sensors and actuators as a part of the whole building automation system is

overlooked. Moreover, the dynamic of the building modifications, once the building is commissioned, is often underestimated; the occupants starting to interact with the building. This new dynamic does not necessarily correspond to the one on which the building and its automation systems were once conceived. On the other hand, the acceptance of new technologies, and their coherence with the existing one for the users are not sufficiently taken into account due to the market pressure for rapid commercialization. Finally, and more specifically, the existing commercialized technologies do not allow for fast, an accurate on-the-fly reliable evaluation of the visual discomfort sensations of the users.

It is an emerging trend for providing facilities and test-benches for pre-validating building

automation technologies and addressing these issues before commissioning them to the market. Several research communities have opted for alike approaches allowing for human-building interact monitoring, reconfigurable lighting and envelope (Living Lab [3]), rotating test-beds (FLEXLAB [4]), green Star rated commercial buildings[5]. In the LESO solar experimental building located on the EPFL Campus (Lausanne, Switzerland), a *system level, user centric* approach is adopted thanks to a new integrated platform for testing the global performance of a High Dynamic Range (HDR) vision sensor. This platform was developed as an ad-hoc platform to the existing building communication system (established on 2000), a comprehensive system that can monitor and log the data of more than 700 sensors and actuators of 14 offices rooms

In this article, the physical layout, communication topology as well as sensors calibration procedure of the proposed ad-hoc platform are exposed. The performance results of an integrated daylighting and electric lighting controller are presented and discussed.

## 2 EXPERIMENTAL SETUP

Two identical south-facing office rooms (Fig. 1) of the LESO solar experimental building were set-up in order to carry-out field-test experimentations. Both were equipped with a conventional window on the lower part and an *Anidolic Daylighting System* (ADS) on the upper part. This system collects direct and diffuse daylight issued from the sun and the sky vault through a zenithal collector, composed of an anidolic element protected by a double glazing [6]. The floor area of each test room is identical and equal to  $15.7 \text{ m}^2$ ; the room height is  $2.8 \text{ m}$ . The two office rooms are equipped with the sensors and actuators described here.

### 2.1 HDR vision sensor

The introduction of an HDR vision sensor to the building automation is the principal innovation of this research work. The reader is encouraged to refer to [7] for ample information regarding the robustness and accuracy of the sensors. They were used to measure two variables: the Daylight Glare Probability (*DGP*), and the workplane horizontal illuminance ( $E_h$ ). The first variable, measured by the first HDR vision sensor, quantifies the probability of experiencing discomfort glare for the scene captured by the vision sensor and is used for sake of protecting the occupants against glare sensations. The second one was used for assuring the required illumination on the work plane for specific work based on lighting norms ([8]). The second sensor was mounted on the ceiling (Fig. 1) and by predefined zone from its luminance mapping, an estimation of  $E_h$  is obtained (section 4.1). The

sensor was attached to a metallic plate mounted on a roller so that its position can be modified if needed. On the other hand, since the HDR vision sensor is equipped with a fisheye lens, the horizontal illuminance on one or several work station(s) located in the office can be monitored at each snapshot.

The other vision sensor is located as close as possible to the user's view point and mounted on a tripod to monitor the main photometric variables (e.g. pupilar illuminance, average luminance, etc.) as well as all well known glare indices, such as the Daylight Glare Index (*DGI*) and the Daylight Glare Probability (*DGP*). Nevertheless, only *DGP* was the one used for the control platform. The exact sensor location and orientation will be explained in Section 4.1 Both sensors have their own fixed sampling frequency and as soon as the required data are obtained, they are available for the telemetry (LAN line). The data remains there till the next sampling iteration is done; the calculated data are not registered on the sensors' embedded platforms.

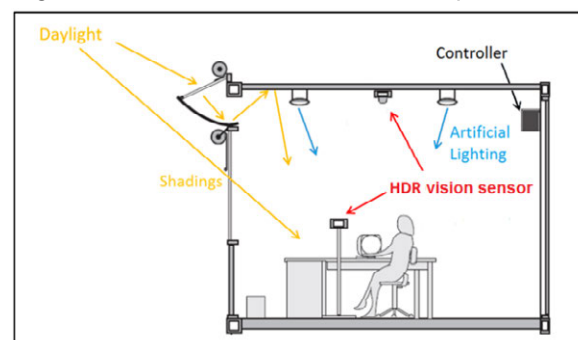

Fig. 1: Physical layout of an office room used as a test bench for the novel controller.

### 2.2 Illuminance sensor and presence detector

A conventional illuminance sensor is permanently mounted on the ceiling and looking downward in the second office room; it measures an average luminance in a given cone which can be translated in work plane illuminance, assuming a constant desk reflection factor. The data is captured and stored in a 4 bytes format to the KNX system. The calibration process is explained in section 4.2. The data is generally saved when a data variation equal or larger than a certain threshold (currently 15 lux) is observed. Thus the illuminance records in the database do not have fixed sampling rate.

### 2.3 Energy metering

A 3-phase energy meter (*hager TE360*) was installed in each office room to monitor the following energy consumptions per phase: (i) electric lighting; (ii) electric heating and motorized shading and (iii) plug loads. The latter measures instant power consumptions (W) as well as partial and total active energy consumption (KWh) on each phase.

## 2.4 Motorized external shading

Each office is equipped with two external motorized fabric blinds. Each blind can be driven by two manual switches inside the office room. The upper blinds cover the ADS window and are occasionally used to reduce the rooms' workplane illuminance when the users feel that the daylight flux is too large in the office; they are also used for glare control (i.e. to prevent direct sunlight from falling on the VDT). The lower one, however, are used less frequently by most users and serve mainly for thermal reasons. The sun shadings can also be controlled through a KNX communication network: the shadings do not have position sensors, thus, they are fully retracted for initialization at the beginning of each experimentation. During the latter, a command is sent to the shadings by defining the "duration" of their raising or lowering at a constant speed. The total time required for lowering/raising each sun shading was previously measured. The final position after each movement was recorded and used as initial position for the next movement.

## 2.5 Lighting

The LED lighting installation (Regents Lighting SA 78H14L1224JA) consumes 23W with a 2400 lm luminous flux, a 4000K correlated color temperature (CCT), a color rendering index (CRI) of more than 80 and Unified Glare Rating (UGR) lower than 22. The lighting system is dimmable and controllable either through a DALI protocol or manual switchers. The dimming functionality is possible through 4-bit large data. The status of the lighting system (consumed electric power and on/off status) is accessible through the KNX communication network.

## 3 CONTROL PLATFORM

### 3.1 Communication platform layout

An ad-hoc control platform was set-up to guarantee the proper data acquisition and logging, flawless initialization as well as actuators commanding. The topology of this system is shown in Fig. 2; It is installed on a PC labeled "control platform" (#1 in Fig. 2). This PC performs the on-the-fly data acquisition, hosts the controller, sends the commands to the actuators and finally, logs the corresponding data. In other words, the whole procedure described in Fig. 3 is hosted in this *control platform*. The data transfer between relay units and the control platform is carried out through the "mapped drive" technique provided by MS Windows; it is the most robust method for data synchronization between different platforms which are all connected to the internet.

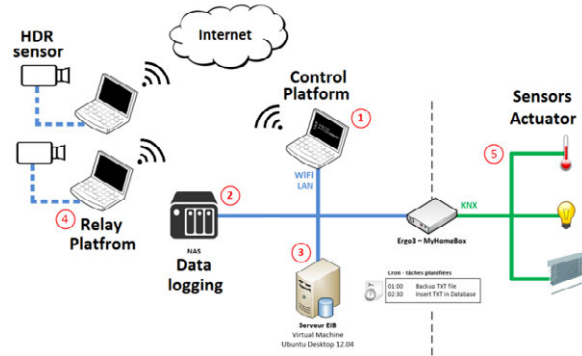

Fig. 2: Communication platform layout.

### 3.2 Control Platform execution block diagram

The control platform was established based on the following principal strategies:

- Data should be registered as received by the master platform in order to avoid a loss of information if any unforeseen problem occurs. They should be stored in a folder with an easily recognizable label.
- The controller's commands (output values) are applied to the actuators if the "actuation conditions" are met. As an example, the shading positions are amended if the new position differs from more than 15/30% (lowering/raising) from the current position. Similarly, the actions are applied only if 15 minutes and more are elapsed from the previous actuation (inspired by [9]).
- The platform should be designed flexible enough to allow for the introduction of any type of new control strategy. In other words, the platform should manage the input data to the controller and retrieve the output data from the controller in a structured standard format. This flexibility allows the platform user to introduce his controller in a time efficient manner by including only one file (the controller) in the predefined location and to readily evaluate its functionality. On the other hand, masking the physical and logical addresses of the actuators and the sensors with "user-friendly labels" would ease the utilization and reduce ambiguity.
- The platform should be flexible enough to accommodate a timely efficient introduction or elimination of a sensor or an actuator.
- The control platform should have a "control board" with an accessible code location (evidently at the beginning) so that the user has the possibility to modify the key parameters of the platform in a straightforward way without exploring the whole platform.
- Finally, proper structure and classification for the files managing sensors and actuators would lead to a faster debugging and tuning of the control platform.

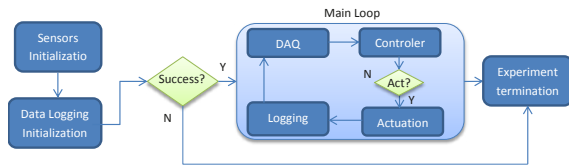

Fig. 3: Control Platform execution block diagram.

The *sensor initialization* block illustrated in Fig. 3, allows the platform verifying if all the sensors are functional and if there is an access to the sensor readings. Control platform requests for a sample from the relay platforms and by examining it determines whether the HDR vision sensors are properly functional. On the other hand, the shading system is initialized and fully raised to mark the initial state. The status of the electrical lighting is also recorded.

The *main loop* block contains four action blocks and a conditional one. The DAQ block prepares the input data for the control block. This block verifies the data correctness by comparing them with the expected ranges. In the next step, the control block generates the appropriate command for the building actuators based on the algorithm loaded in the initialization section.

In the next step, a decision-making procedure is carried out to find out if the generated command should be actually executed or not. This process is based on several principles, such as:

- (i) The actuation should be carried out more than a certain number of times per day, since too many amendments of the lighting and sun shading would annoy the office occupant.
- (ii) The control actions are applied to the controllers provided that the amendment of the shadings' position is larger than a given threshold. For instance, if the newly proposed sun-shading position differs from the current one by more than 30%, the new command is passed to the shading actuators.
- (iii) In the actuation phase, the commands are sent through the KNX network insuring that they are properly executed.
- (iv) In any case, the whole acquisition data and the input and output variables of the controller are stored into a local hard disk.
- (v) As soon as the conditions for ending the experiment are met, the main loop ends and the whole data registered on the local hard disk are copied into a database located on an EPFL server so that the risk of data loss is minimized.

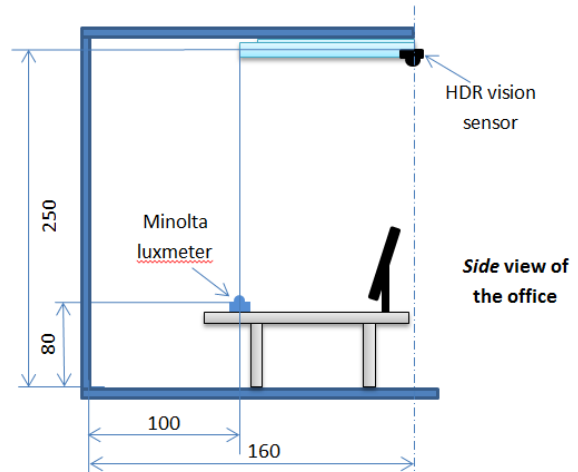

Fig. 4: HDR vision sensor mounted on the ceiling with a work plane illuminance meter calibration setup.

## 4 CALIBRATION

### 4.1 Ceiling mounted HDR vision sensor

An HDR vision sensor, mounted on the ceiling and facing downward, was used for estimating the work plane illuminance (Fig. 4). This technique is based on the assumption that all surfaces in the office room are Lambertian meaning that their apparent brightness is constant whatever the observer's angle of view. This means that the surface's luminance is isotropic and that the luminous intensity obeys to a cosine law. In other words, the surface illuminance is linearly proportional to the observed luminance. On the other hand, since it is equipped with fisheye lens, the illuminance of one or several work spaces located anywhere in the office can be monitored at each sampling (Fig. 5).

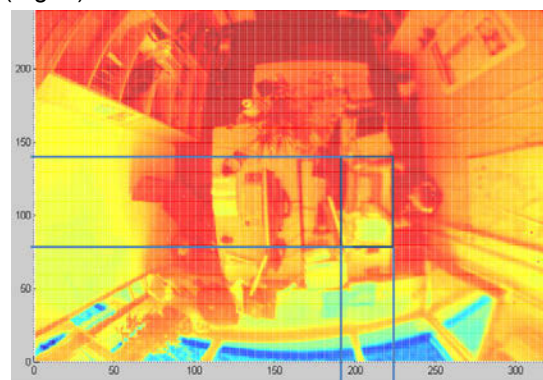

Fig. 5: View from the ceiling mounted HDR vision sensor with a defined zone corresponding to the work plane.

### 4.2 Illuminance meter

The ceiling mounted luminance meter has been calibrated using a conventional illuminance meter. A Minolta illuminance meter was placed for that purpose directly underneath the ceiling

mounted HDR vision sensor to measure the horizontal illuminance on that table; 160 samples were recorded leading to the calibration illustrated on Figure 6.

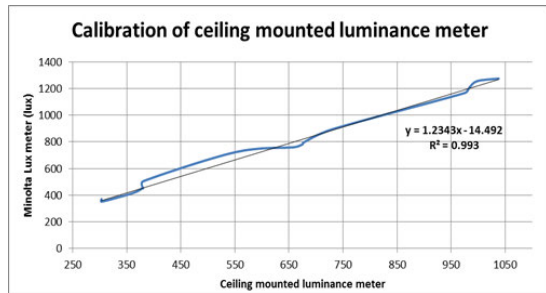

Fig. 6: Calibration of the ceiling mounted luminance meter by means of Minolta CL-200A illuminance meter.

A linear correlation between the ceiling mounted luminance meter readings ( $L_{sensor}$ ) and the workplane illuminance ( $E_h$ ) was obtained; the average mean square error is  $\pm 27$  lux. Thus:

$$E_h = 1.2343 \times L_{sensor} - 14.492 \pm 27 \text{ [lux]} \quad (1)$$

## 5 RESULTS

In order to verify the robustness and the performance of the platform, a controller based on fuzzy logic was set-up and tested during the afternoon of October 9 2015 (partially cloudy). The input data to the controller are:  $DGP$ ,  $E_h$ , height and azimuth of the sun. The outputs are: relative coverage positions of the two sun shadings (for ADS and normal windows) as well as electric lighting status (0/100). The reference for defining comfort zone for horizontal work plane illuminance and  $DGP$  are 200/1500 lux and 30%. The set point value for  $DGP$  is derived from [7].

Fig. 7 shows the  $E_h$  and  $DGP$  ranges during the almost 5 hours duration of the 'in situ' experimentation in the afternoon. Sun shadings positions as well as the electric lighting status are illustrated in Fig. 8.

One can observe that the workplane illuminance exceeded the comfort range boundaries at 13:50 and that the bottom and top shadings are moved respectively, to 17% and 52% window coverage positions. Consequently,  $E_h$  is brought back to the visual comfort range. Since  $DGP$  was in the comfort range ( $DGP$  lower than 30%), the controller was still not activated based on this variable. At 14:16, as the  $E_h$  dropped below the comfortable range (200 lux) the sun shadings were retracted to increase the daylight flux into the office through the windows. It is worth noticing that since this action was sufficient for providing enough illumination on the work plane, the electric lighting system was not activated.

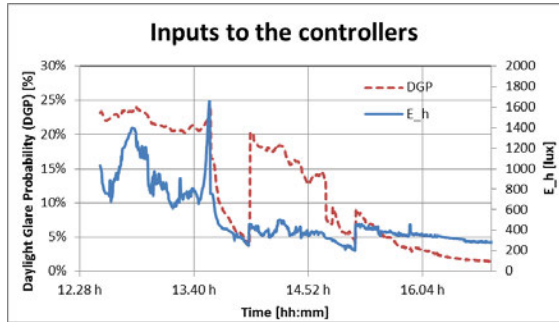

Fig. 7: Input variables to the controller during a test-field on 9<sup>th</sup> October 2015.

Finally, at 15:22, the interior illuminance reached the lower boundary of the comfort range for  $E_h$ , (i.e. 200 lux): the electric lighting was activated in order to compensate for the shortage of daylight. The lightings remained turned on till the end of the duration of the experiment.

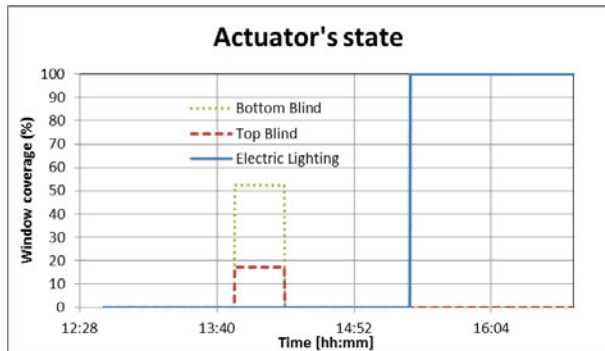

Fig. 8: State of the actuators during a test run on 9<sup>th</sup> October 2015.

During the test-field, the platform remained functional; the monitored data as well as the input and output variables of the controller are stored on the local disk of the control platform.

## 6 CONCLUSION

The setting-up of an ad-hoc control platform for the field-testing of a controller based on novel HDR vision sensors was presented. This platform was installed in two office rooms of the LESO solar experimental building on the EPFL campus in Lausanne, Switzerland. A data acquisition and actuation platform driving two motorized sun shadings per office, a dimmable electric lighting system, a presence detector, energy meters, a ceiling mounted luminance meter as well as two High Dynamic Range (HDR) vision sensors were set-up for that purpose. A controller based on HDR vision sensor was successfully implemented in an LESO office room in order to evaluate its robustness and performance. This platform is currently ready to operate with advanced controllers in order to test several energy efficient control scenarios/algorithms.

## 7 ACKNOWLEDGMENTS

This work was supported by the Commission for Innovation and Technology (CTI) of the Swiss Confederation through the Swiss Competence Center for Energy Research on Future Energy Efficient Buildings and Districts (SCCER FEED&B).

## 8 REFERENCES

1. P. H. Shaikh, N. B. M. Nor, P. Nallagownden, I. Elamvazuthi, and T. Ibrahim, "A review on optimized control systems for building energy and comfort management of smart sustainable buildings," *Renew. Sustain. Energy Rev.*, vol. 34, pp. 409–429, Jun. 2014.
2. W. L. Paul and P. A. Taylor, "A comparison of occupant comfort and satisfaction between a green building and a conventional building," *Build. Environ.*, vol. 43, no. 11, pp. 1858–1870, Nov. 2008.
3. J. Kim, J. E. Braun, A. Tzempelikos, S. M. Jischke, and W. Lafayette, "Energy Savings Potential of Passive Chilled Beam System as a Retrofit Option for Commercial Buildings in Different Climates Ray W. Herrick Laboratories, School of Mechanical Engineering, Purdue University, School of Civil Engineering, Purdue University," in *International High Performance Buildings Conference*, 2014, p. 107.
4. Berkeley Lab — Lawrence Berkeley National Laboratory, "Flexlab," 2016. [Online]. Available: <https://flexlab.lbl.gov/>. [Accessed: 12-Jan-2015].
5. M. B. Hirning, G. L. Isoardi, S. Coyne, V. R. Garcia Hansen, and I. Cowling, "Post occupancy evaluations relating to discomfort glare: A study of green buildings in Brisbane," *Build. Environ.*, vol. 59, pp. 349–357, Jan. 2013.
6. F. Linhart, "Energetic, Visual and Non-Visual Aspects of Office Lighting," Swiss Federal Institute of Technology (EPFL), 2010.
7. A. Motamed, L. Deschamps, and J. Scartezzini, "Validation and Preliminary Experiments of Embedded Discomfort Glare Assessment through a Novel HDR Vision Sensor," in *CISBAT*, 2015.
8. "Guide to DIN EN 12464-1 Indoor Workplace Lighting." [www.all-about-light.org](http://www.all-about-light.org), pp. 1–44.
9. A. Guillemin, "USING GENETIC ALGORITHMS TO TAKE INTO ACCOUNT USER WISHES IN AN ADVANCED BUILDING CONTROL SYSTEM," 2003.





## Expanding Boundaries: Systems Thinking for the Built Environment

### DYNAMIC ENERGY WEIGHTING FACTORS TO PROMOTE THE INTEGRATION OF RENEWABLES INTO BUILDINGS

L. Baldini<sup>1\*</sup>

<sup>1</sup> Swiss Federal Laboratories for Materials Science and Technology,  
Duebendorf, Switzerland

\*Corresponding author; e-mail: luca.baldini@empa.ch

#### Abstract

One of the major challenges for the future of our energy systems is the integration of renewables and the continuous replacement of fossil and nuclear fuels in energy generation. Buildings play a very important role in this respect because of their large share in global energy usage and GHG emissions but as well because of their potential for integrating energy harvesting devices such as PV, wind turbines or solar thermal collectors.

On EU-level (Energy Performance of Buildings Directive 2010/31/EU) the target for nearly zero energy buildings (NZEB) was formulated without giving a clear definition for its implementation. The net zero energy requirement does make a statement regarding energy efficiency and the usage of renewable energy in buildings but it does not address the requirement of a proper integration of renewables into buildings to avoid peak loads on the grid. Typical performance evaluation of buildings as suggested by European Standards (e.g. EN 15603:2008) is based on the use of static weighting factors such as annually averaged primary energy factors or CO<sub>2</sub> intensities per energy carrier.

This paper suggests using dynamic weighting factors instead to judge the building performance and to set incentives for a better integration of renewables into buildings. A specific weighting scheme is suggested and has been applied to the research and innovation platform NEST on the Campus of Empa - Swiss Federal Laboratories for Materials Science and Technology. First results indicate that for the cases considered, static weighting of energy use is overestimating the energy performance of the building by 10 to 15%.

#### Keywords:

energy weighting; dynamic weighting factors; energy performance; net zero energy building

## 1 INTRODUCTION

An increase of efficiency and integration of renewables at a building or district level is a key issue of the energy transition aimed at by the Swiss energy strategy 2050. Similar goals are envisaged at a European and international scale. According to the Energy Performance of Buildings Directive (EPBD 2010/31/EU), all buildings realized after 2020 within Europe shall be implemented as so called nearly zero energy buildings (NZEB) showing a net zero energy balance over the year. European countries are requested to define their building codes accordingly in order to achieve the formulated

goal across Europe. Although there is a binding goal being formulated, a clear definition of the NZEB is lacking. There are many different attempts for consistent yet different definitions of NZEB as presented e.g. by [1], [2], [3] as well as several critical reviews [4], [5]. Coming out of a task force of the Federation of European Heating, Ventilation and Air Conditioning Associations (RHEVA), [2] presents a technical definition of NZEB closest possible to the EPB Directive. This definition shall serve as a basis for European countries to establish their proper definition framework within national building codes. The definition of NZEB suggests the application of an

export/import energy balance leading to the net delivered energy. Weighting of the energy flows per energy carrier happens with national primary energy factors to achieve a net zero yearly balance. While there is no discussion on the shortcomings of a static energy balance discussed in [2] other authors like [3], [6] address the importance of dynamic effects for grid loading and suggest additional metrics to be used along with the basic static NZEB definition. One major critique using dynamic measures for load matching between the source and the sink is the increased complexity during the design phase and the need for more advanced and dynamic simulation methods with high temporal resolution.

The method presented in this paper replaces the static definition as typically found for NZEB by introducing dynamic weighting factors. With this dynamic nature it encourages the implementation of building's energy systems such that peak loads in wintertime are minimized and partly shifted to the summertime when more electricity from renewable sources is available.

The dynamic weighting scheme leading to a weighted net energy performance figure for a building has been developed in the context of the research and innovation platform NEST on the Campus of Empa - Swiss Federal Laboratories for Materials Science and Technology. This platform is hosting a large number of experimental buildings (called units) that are hooked up to a central energy network that allows for studying the energy performance of individual units or of a compound as found within districts. The NEST-specific performance figure was created with the idea in mind to set a standard which is more advanced compared to existing ones as well as providing the possibility to control the implementation of renewables on the level of the individual units. NEST is hence the first example where this energy performance metric has been applied and it is the place where it will be further developed to hopefully be applied to buildings outside of the research domain in the near future.

## 2 METHODS

A dynamic weighting scheme has been defined for the energy use in buildings. Key in this weighting scheme is the consideration of differences between seasons and weekdays/weekends. The differences between weekdays and weekends are reflected in the energy prices of the electricity spot market which again reflects the demand pattern (see figure 1a and 1b).

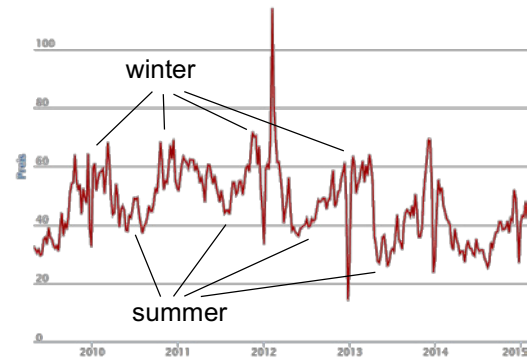

Fig. 1a: Spot market prices for electricity reflecting seasonal fluctuations.

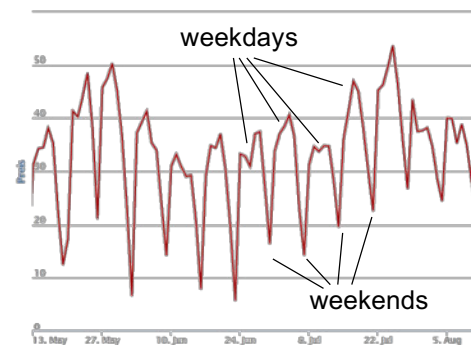

Fig. 1b: Spot market prices for electricity reflecting weekly fluctuations.

Electricity prices are highest in wintertime and on weekdays when demand is highest. This price signals are used for weighting of electricity use in NEST after a normalization and smoothing procedure has been applied. Six different prices or weights result for the three seasons (winter, summer, spring/autumn) and the weekdays or weekends.

### 2.1 Exergy-based weighting of energy use

Thermal energy prices depend on the temperature of a respective heat source as well as on a reference temperature and can be quantified applying the concept of exergy. The exergy of a heat stream can be calculated by multiplying it with the Carnot factor as shown in equation (1)

$$\dot{E}_x = \left(1 - \frac{T_0}{T}\right) \dot{Q} \quad (1)$$

If the temperature of the heat stream is below the reference temperature the exergy supplied can be considered "cold exergy" as supplied by an ideal cooling machine. In this case the exergy calculation of a heat stream needs to follow the definition given in equation (2).

$$\dot{E}_x = \left(\frac{T_0}{T} - 1\right) \dot{Q} \quad (2)$$

Relevant for the judgement of the thermal energy price for a unit is the net exergy demand which is defined by the exergy supplied minus the exergy returned. The exergy demand of a system can be seen as the electricity equivalent of the thermal energy demand and again be weighted using



### 3.3 Comparison for simulated office case within NEST

The NEST-specific net energy performance figure was also evaluated for an office unit implemented within NEST using simulation results provided by the unit's research partner (Lucerne University of Applied Sciences and Arts). A comparison of the net energy performance figure using dynamic NEST-specific weighting and the static weighting respectively identifies 12.7% lower values for the latter case. In case of dynamic and static weighting energy performance take values of 171.2 MJ/(m<sup>2</sup>\*a) corresponding to 47.5 kWh/(m<sup>2</sup>\*a) and 149.5 MJ/(m<sup>2</sup>\*a) corresponding to 41.5 kWh/(m<sup>2</sup>\*a) respectively.

## 4 DISCUSSION

An important strength of the energy weighting method presented is the flexibility it offers to the designers. Because of the performance requirement being formulated as a weighted sum the designer is free to make choices regarding individual summands. The designer could for example tune his energy concept towards a maximization of solar electricity generation while making moderate efforts on the level of the building envelope or vice versa.

A major goal of the energy weighting method discussed is to facilitate and incentivize the integration of renewables on a building level while accounting for the limitations given by the electrical grid. Assuming a high market penetration of NZEBs the load on the electrical grid and the need for regulating power capacity will increase unless there is any local storage installed. Using a dynamic weighting scheme and a performance goal based upon, it is possible to incentivize the implementation of energy concepts with low electricity peaks in wintertime and/or the installation of local energy storage.

The NEST-specific weighting method was applied along with a comparison to static weighting for two cases. Both cases revealed the significance of the dynamic weighting as the static weighting consistently led to lower values of the specific energy use of the building. The reason for the more optimistic judgment of the energy performance taking a static perspective is mostly due to the fact that high energy demands stemming from heating and domestic hot water applications in wintertime are not penalized.

The method presented essentially captures dynamic effects on different time-scales (seasonal and weekly). Fluctuations due to seasonal variations can be easily captured even when an analysis with low temporal resolution such as a month is applied. As such it can also be applied in an early design phase to guide systems design accordingly. Higher resolution of

the method of course requires again higher temporal resolution on the simulation side typically in the range of an hour.

An important benefit of the presented method to be mentioned is its flexibility. While the method can remain unchanged the pricing scheme can be easily adapted to actual goals formulated by environmental policies.

The NEST-specific performance criterion is formulated as a net energy balance accounting for various energy supplies and demands. The deduction of the design limit was based on the demand side. As a consequence, the actual formulation allows units within NEST to fulfil the energy performance requirement without any energy harvesting implemented. For units on the roof-top of the NEST platform being highly exposed to the sun an additional requirement for the solar fraction of the energy demand is formulated. With a view on the definition of NZEB it is now straight-forward to change the design limit of the NEST-specific net performance figure to zero asking the roof-top units for a substantial amount of renewables to be integrated by design.

## 5 CONCLUSIONS AND OUTLOOK

This paper presented a dynamic weighting method to assess energy performance of buildings. For its application in the innovation and research platform NEST a design limit for a weighted net energy performance figure has been defined. The method presented is guiding the design of building's energy systems towards a better integration of renewables in terms of grid compatibility. Two cases studied, delivered first indications that a static method is overestimating the energy performance, leaving out the aspect of grid compatibility. The lack of accounting for this requirement in many today's methods such as NZEB is seen as one of the major shortcomings that need to be addressed in the implementation of tomorrow's building codes.

In future, more experience with the application of the dynamic method in the design phase as well as more results from simulation and actual operation need to be collected for upcoming NEST units. A major goal is also to find out about how strongly technology choices can be influenced by different pricing schemes and how those schemes need to be adapted to further instigate integration of renewables and installation of local energy storage. Finally, a link of the energy use to CO<sub>2</sub> emissions and eventual embodied emissions of building materials used shall be studied.

## 6 ACKNOWLEDGMENTS

Thanks to the NEST team for providing useful support in developing a dynamic energy weighting method.

## 7 REFERENCES

1. Torcellini, P. and Pless, S. and Deru, M., Zero Energy Buildings: A Critical Look at the Definition. August 14–18, 2006: ACEEE Summer Study Pacific Grove, California.
2. Kurnitski, J., et al., How to define nearly net zero energy buildings nZEB – REHVA proposal for uniformed national implementation of EPBD recast. May 2011: REHVA Journal.
3. Sartori, I. and Napolitano, A. and Voss, K., Net zero energy buildings: A consistent definition framework. *Energy and Buildings* 48 (2012): p. 220–232.
4. Marszal, A.J., et al., Zero Energy Building – A review of definitions and calculation methodologies. *Energy and Buildings* 43 (2011): p. 971–979.
5. Deng, S. and Wang, R.Z. and Dai, Y.J., How to evaluate performance of net zero energy building e A literature research. *Energy* 71 (2014): p. 1-16.
6. Cao, S. and Hasan, A. and Siren, K., On-site energy matching indices for buildings with energy conversion, storage and hybrid grid connections. *Energy and Buildings* 64 (2013): p. 423–438.





## Expanding Boundaries: Systems Thinking for the Built Environment

### SOLAR ENERGY AVAILABILITY IN URBAN DENSIFICATION PROCESS IMPACT ON EXISTING BUILDINGS IN A SWISS CASE STUDY

C.S. Polo López<sup>1\*</sup>, M. Sala<sup>2</sup>, F. Frontini<sup>1</sup>, L. Tagliabue<sup>3</sup>, E. De Angelis<sup>2</sup>, G. Pansa<sup>2</sup>

<sup>1</sup> University of applied sciences and arts of southern Switzerland SUPSI, Trevano, CP 105, CH-6952 Canobbio, Switzerland

<sup>2</sup> Politecnico di Milano, Architecture, Built environment and Construction Engineering Department, Via Ponzio 31, 20133 Milano, Italy

<sup>3</sup> University of Brescia, Department DICATAM, Via Branze 43, 25123 Brescia, Italy

\*Corresponding author; e-mail: cristina.polo@supsi.ch

#### Abstract

Urban densification is a growing phenomenon that is strongly changing the interaction between existing buildings and the surrounding environment. As example, in Switzerland, the Cantonal Director Plan, expected for the next years, will change the urban density allowing to raise the three to four floor high buildings now separated by not too wide streets, to get over up to eight floors, without modifying the width of street layout. The paper deals with a case study located in Paradiso municipality, part of Lugano's settlement (CH) where the impact of the future buildings on pre-existing buildings, especially on the historical heritage has been quantified to understand the energy fallout by different points of view (i.e. solar energy availability, daylighting, energy saving, comfort and energy production through active solar systems, etc.). The paper focuses on a phase of a wider project aiming to evaluate the complexity of energy performance change in buildings and provide guidelines of intervention to assess the suitability of urban development solutions in dense urban context.

#### Keywords:

Architecture; building and planning; Energy technologies; Heritage buildings

### 1 INTRODUCTION

The rational use of energy towards greater efficiency and the reduction of climate altering gas emissions, the transition towards autonomy and self-sufficiency through renewable energy together with the energy supply issue are aspects that need to be considered when designing buildings and urban centres. Urban policies, local authorities and many communities recognize the economic and environmental benefits of dense urban environments and at the same time global energy stated goals for the near future are pushing for a greater improvement in energy efficiency in the building sector considering also the benefits of local renewable energy, generally, and solar energy, specifically [1]. The process of land planning and urban development requires long timeframes that are sometimes in opposition to the rapidity of these changes favoured by energy policies at the national and global level. In

particular, urban densification policies can influence the energy demand and the solar availability of pre-existing buildings but especially on the protected heritage. Urban planning strategies determine the possibility to exploit solar irradiation as solar passive/active, daylighting, human comfort, etc. In the same way, urban densification can influence the building energy demand and building thermal performance, the level of conservation of existing buildings (in particular historical buildings) with also implications in the urban microclimate [2].

The opportunity to use the solar radiation, the natural lighting and ventilation in order to reduce energy dependency (for heating, cooling and lighting purposes) and to assure comfort, could be compromised in an urban environment with a fast, dense and excessive growth. The urban pattern and the building configuration can modify key aspects that are related to the rational use of

natural and environmental resources. The need to accurately quantify these effects is a strategic factor for predicting decreases in solar availability to understand the actual impacts to drive the corrective measures, if possible, and to pursue a methodology of analysis that defines recommendations and theoretical principles. Researchers investigating these aspects can strongly support planners to achieve this objective to enact standards related to solar exploitation assessing the better way to integrate solar energy aspects, overtaking barriers towards solar rights definition [3].

## 2 DATA AND METHODS

At urban level in the Ticino Canton, urban densification strategies are underlined among the objectives of the Cantonal Director Plan (Flächennutzungsplan) [4]. Lugano Paradiso district is currently undergoing a profound change towards densification of the urban environment with the new master plan now in act. With the intent to revitalize the city centre, the new Plan already underway drives major changes on existing urban development patterns. The detailed plan of the common centre (PPCC, last update of the plan was published in May 2011, endorsed by the State Council in June 5, 2012) defines maximum volumes footprint to nine floors and contiguity mandatory with closed and compact urban fabrics, instead of the traditional division of land parcels. This research project, related on a real case-study, investigates how urban modifications, in particular urban densification policies, can influence the energy behaviour, the solar availability and comfort of pre-existing buildings, in particular on the protected heritage. Four protected heritage buildings were identified in the area: B.1 Palace Riva Paradiso (A4905); B.2 Hotel Victoria (A4906); B.3 Palace G. Guisan Street (A4907); B.4 Posthotel Simplon (A4908).

The paper focuses on a phase of a wider project, aiming to evaluate the complexity of energy performance change in buildings and provide guidelines of intervention to assess the suitability of urban development solutions in dense urban tissue [5]. Three aspects that will be addressed are described in the following sections.

### 2.1 Solar irradiation availability

Evaluation of the impact of the new buildings height on existing and historical buildings through the analysis of solar irradiation availability and the assessment of the human comfort in urban environment.

### 2.2 Human comfort assessment in urban environment

Identification of the differences between the current scenario and the future aspect of the city referred to the capacity of the buildings to use

solar energy for thermal passive conditioning and daylighting purposes.

### 2.3 Energy efficiency of pre-existing buildings affected by urban modifications

The aim is to highlight strategies for harmonizing the energy needs of the buildings considered as a part of an urban context (new and existing buildings and historical buildings as part of this second category) to which the plan will be applied. The analysis has been carried out on multiple levels comparing the new scenario with the existing scenario and considering the effects of the loss of sky factor and the energy consumption in winter and summer due to thermal and lighting needs. To better assess the real impacts of the new dense urban plan, a structured analysis with dynamic simulation tools in combination with analytical studies have been regarded as crucial.

## 3 RESULTS

A comprehensive study of the urban area of the City Centre of Paradiso has been made. The results of this site survey allows to have a first estimation on solar urban transformation for each area. In particular, an exhaustive analysis is being carried out for each historical building in the area to define the solar obstructions in the current situation (Old Master Plan, Old MP) and future situation (New Master Plan, New MP).

### 3.1 Solar irradiation studies

To assess solar irradiation and shadow changes and the real impact of new and existing buildings quantifying the energy impacts in an urban context, solar simulation tools have been used to evaluate the different scenarios. Furthermore, simpler methods, as Sun-path diagrams can be used in combination with the simulation analysis completed using 3D Ecotect software. Solar obstructions can be read out directly on the diagrams, as the position of the sun in the sky at any time of the day on any day of the year can be read directly from the Sun-Path Diagrams. A more accurate analysis could be performed by using the HORlcatcher instrument developed by Meteotest. With a digital camera and a horizon mirror (spherical convex mirror) it is possible to register the horizon in the field quickly and efficiently in order to calculate limitations of the sunshine duration and irradiation due to obstacles and serves to obtain three-dimensional projections of the space projected in the mirror dome. Specific software calculates the sun's orbit, which is put in relation with the horizon and specific processing image software have been used to analyse the current urban status [6]. The analyses have been completed near the protected buildings under study, at ground level (bottom) where major impacts will be expected and at roof level (top) to assess the differences. Changes in solar irradiation at roof level will have an impact on



potential solar active installations, while at ground level, studying the effects on each façade will show the possibility to exploit passive solar strategies. Polar Sun-Paths, using the Stereographic Projection, have been used to pursue the differences from the old and the new scenarios as seen in the next figures (Fig. 1 and Fig. 2).

**Building 3:**

Palace G. Guisan Street (A4907)

- Stereographic diagram -

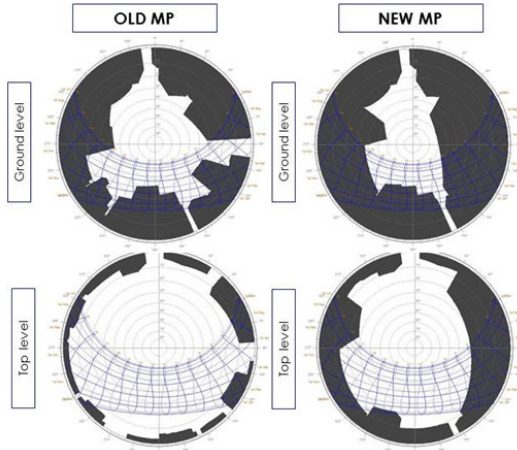

Fig. 1: Example of Ecotect sun-path diagrams (Building 3) calculated for the current master plan scenario (Old MP) and the new master plan scenario (New MP).

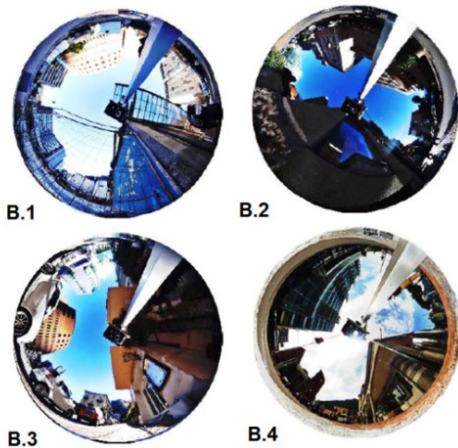

Fig. 2: Photo recorded by HORIcatcher device and modification in HDR format for each location studied near protected buildings.

By comparing the situation before and after, when the urban transformation will be definitely performed and the new master plan completed, it has been possible to calculate the percentage of solar obstruction (sunshine/shading) in each building studied, caused by the other buildings in the area (Fig. 3).

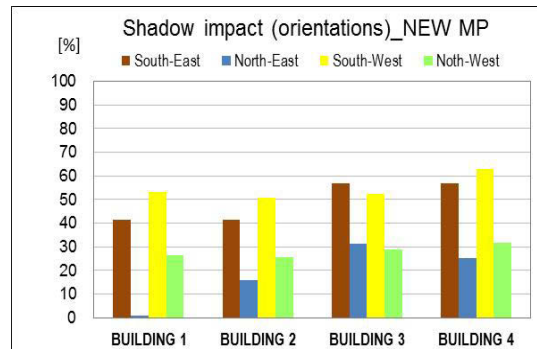
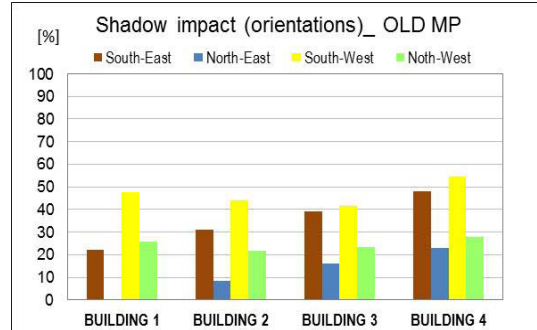
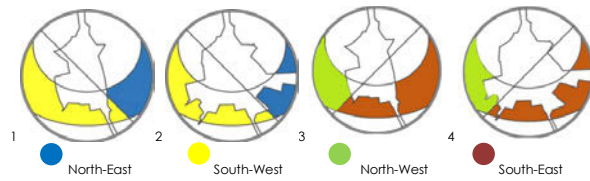

Fig. 3: Images and graphs show the results for different orientations (north-east, south-west and north-west, south-east): according to Fig. 1, image 1 and 3 represent the current situation (Old Master Plan) and images 2 and 4 future situation (New Master Plan).

According to this analysis, the results show that for Building 1 there are slight differences by façades mainly because the surrounding urban area is already modified, while in contrast, the South-Est façade is highly affected. On the contrary, the greatest impacts are observed in Buildings 2, 3 and 4, as more changes are detected in their surrounding area in the future scenario. In these cases, at ground level and mainly in winter time, the situation becomes dramatic with very few hours of sunshine all year round. Particularly in the case of Building 3, for almost all façades (north-east, south-west, north-west or south-east) the situation worsens with the new master plan, increasing the percentage of shade from 6%, in the best case (North-West façade) to 17.5% in the worst case (South-Est façade).

**3.2 Human comfort assessment**

For the assessment of the human comfort differences in the area and bioclimatic techniques have been considered for calculating the ideal "comfort zone" for the specific location of Lugano to establish the aspects that compromise the fully exploitation of the environmental conditions and the possibility to use passive strategies for thermal conditioning. The meteorological climate data of

Lugano was used to perform this study, using average statistical data from the Federal Office of Meteorology and Climatology – MeteoSchweiz. With this data, bioclimatic diagrams have been developed using the CBA diagram (wellness adapted chart) settled on the basis of the Olgyay diagram, incorporating the main strategies of the Givoni diagram [7]. The results can be simplified and represented in an Isoleth map (Fig. 4a), hour by hour and month by month, where it is also possible to associate the areas representing the necessary passive strategies to reach comfort, identified in the CBA chart (1 to 6 zones, Fig. 4a). This graphic has been compared with the same type of diagram (month by month, hour by hour) showing the dynamic analysis results of solar irradiation simulations made with the Ecotect software for the old MP and the new MP (Fig. 4b).

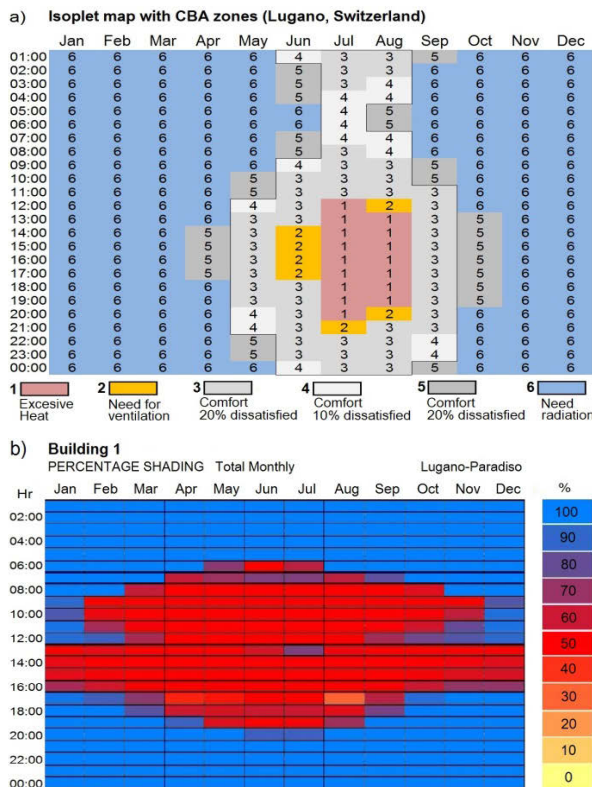

Fig. 4: a) Isoleth map with CBA zones (1-6) represented. The black line identified the period of time where shadow is necessary to prevent overheating; b) Shading graphic example calculated for Building 1.

The software allows evaluating and calculating, for each protected building, the total average percentage of shading generated by the lack of solar radiation due to the surrounding buildings. Areas plotted as number 6 and 5 in the first diagram (6: need of radiation and 5: comfort but, Predicted Percentage Dissatisfied, PPD-Index equal to 20%, based on the Fanger Comfort Model [8]) in order to take advantage of solar gains to maintain comfort should not be shaded (0% shade). By contrast, in the areas identified in Fig. 4, as 4, 3, 2 and 1 (4: comfort, PPD 10%; 3: PPD

20%; 2: need for ventilation and 1: excessive heat) should avoid excessive overheating due to solar radiation (100% shade are required if possible) to maintain comfort.

In the same way, the ideal comfort zone for the site can be also represented in the solar polar sun-path diagram (Fig. 5, where 5.a) represent the comfort zone in summer for Lugano Paradiso; 5.b) represent the comfort zone for winter time; 5.c) represent the solar obstructions assessment by photographic or analytical methods and the 5.d) represent the matching results between solar obstruction and comfort needs (in green are shown the positive effects, while in red the negative effects to the comfort zone). In this way, for example, the impacts could be easily visualized and measured by extrapolating conclusions of the diagrams when this area will be affected by obstructions of the surrounding environment.

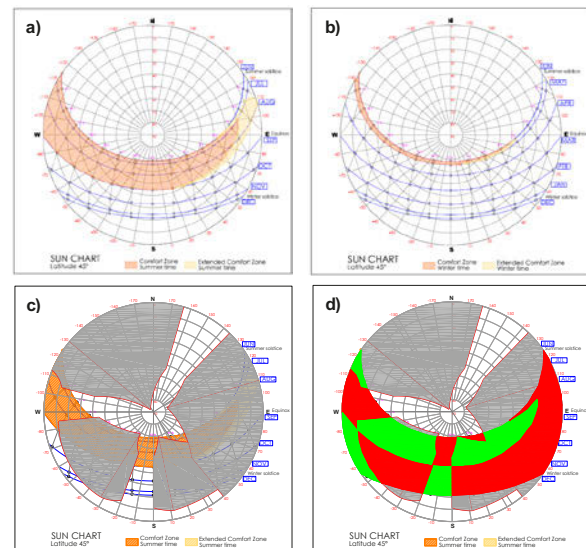

Fig. 5: Comfort zone calculated and represented in the solar polar sun-path diagram (stereographic projection) for Lugano area.

The results summarized in Fig. 6 and expressed in percentage, show that in the summer period although the discomfort predominates, in some cases (Building 3 and 4) the comfort increases slightly for the New MP scenario while only in Building 1 the percentage of thermal comfort time exceeds the discomfort. In winter time, however, for all buildings, the thermal comfort decreases while discomfort increases.

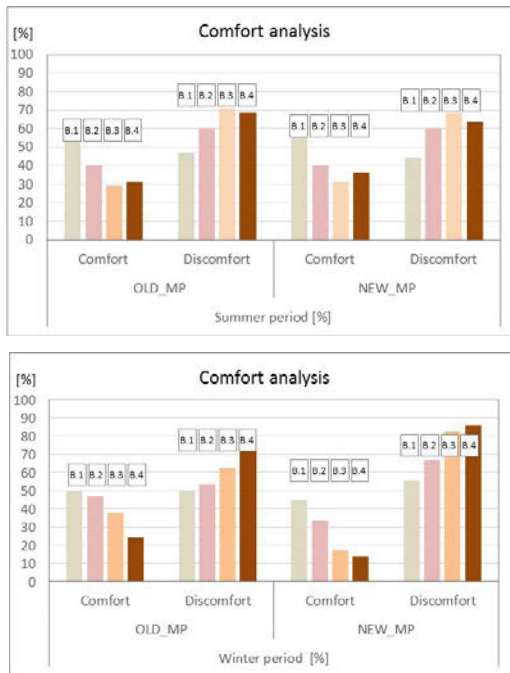

Fig. 6: Comfort zone impacts results for summer time and winter time calculated and represented in the solar polar sun-path diagram (stereographic projection) for Lugano area.

### 3.3 Energy efficiency assessment

In Switzerland, as in other EU states, the problem of energy saving is being supported and emphasized through strategies and regulations at a national and federal level [9, 10]. The cultural monuments, protected by the regulatory plan and immutable during the time, will suffer particular urban densification [11,12] and the need to quantify these effects is a key factor for predicting reductions in solar availability and energy demand of the building.

The analysis focused on Building 3 (Palace G. Guisan Street, A4907), the most influenced by the New MP. This residential building (total gross floor area 1.515 m<sup>2</sup>) was built between the end of sec. 19<sup>th</sup> and early 20<sup>th</sup> centuries. The building has three floors with an unheated basement and stairs. It has several openings (30% of the gross area of the façades) on all fronts and the main entrances are located across the main street (east), Guisan Street. The analysis has been performed with a plugin for SketchUp to perform detailed dynamic energy simulation with EnergyPlus [13] developed by Politecnico di Milano. The building has been simulated in the current context and in the hypothetical future context to quantify the damage in terms of energy demand due to the new context configuration [14] (Fig. 7).

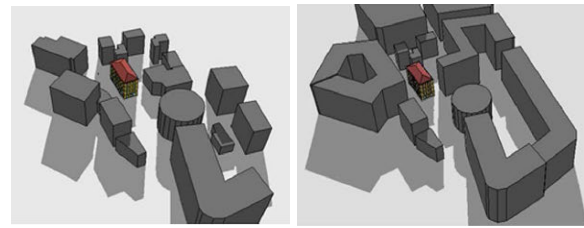

Fig. 7: Comparison between the models with the existing situation (left) and New MP (right).

The analysis considers different construction typologies referred to buildings' age to evidence how technological definition of the envelope affects the energy demand variation. The first construction detail (A) is a '50s wall made by 40 cm of stone with plaster. The second option (B) is a '70s wall with 20 cm of concrete with plaster and the third case (C) is a '80s wall adding to the second a 7 cm cork insulation layer (Fig. 8).

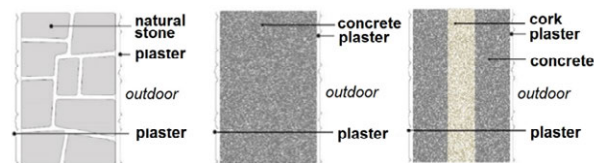

Fig. 8: Construction details of the stratigraphy: building age A (1950), B (1970), C (1980).

The energy demand outcomes with the different envelope definitions are compared in Fig 9. The New MP scenario results consider the Building 3 in the future urban development with the actual envelope (A). The heating demand is well prevailing in comparison with the cooling need. In the new scenario, with a denser urban context, the heating demand increases by about 8.5% in comparison with case A and 20% referred to case C (in case B is almost the same).

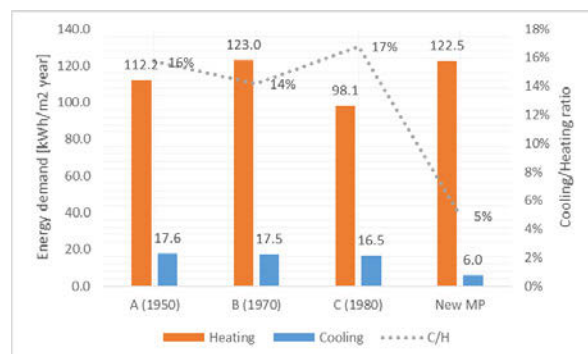

Fig. 9: Energy demand [kWh/m<sup>2</sup> year] for different envelope options and the New MP and cooling/heating demand ratio [%].

The cooling demand shows stronger variations decreasing by 65% with the urban densification. Nevertheless, the energy need in summer with the New MP is 5% of the winter energy need whereas in the existing scenario the average ratio between cooling and heating demand is 16%. Therefore, the urban densification reducing the solar energy incoming in the building can be favourable in

reducing cooling needs, however, the main item in energy consumption of old and historical buildings is evidently the heating demand due to the poor when existing insulation and high thermal mass of the envelope. Furthermore, the window to wall ratio in these buildings is rather limited (30%) however the incidence of solar energy in summer is relevant.

#### 4 DISCUSSION

As stated in this research project, urban planning strategies determine the possibility to exploit solar irradiation as solar passive/active, daylighting, human comfort, etc., factors that could be compromised during urban transformation. As outcome of this analysis, it has been found that street profiles significantly change in the new configuration of the Master Plan affecting solar radiation availability, human comfort and energy performances in pre-existing buildings (focusing this study in protected buildings in the area).

#### 5 CONCLUSIONS

The proposed methodology reached the project such as to properly assess how urban densification policies influence the energy performance, the conservation level and the solar availability of pre-existing buildings focusing mainly on the major impacts over the protected cultural heritage, undergoing transformations of the surrounding environment. This project put a special emphasis on important issues at the time of redefinition of an urban area have implications on historical but also on new buildings to be developed in the future considering the solar active installations that should be integrated to provide energy. Urban environments can significantly vary from site to site, depending on latitude, distances between buildings and height. Therefore, detailed studies based on the shown methodology, are crucial to be adopted from site to site.

#### 6 ACKNOWLEDGMENTS

This project was funded by the Stiftung zur Förderung der Denkmalpflege (Foundation for the Promotion of the Conservation of Historical Monuments).

#### 7 REFERENCES

1. Skovbro, A. Urban Densification – A Sustainable Urban Policy? 2002, The Sustainable City II. Urban Regeneration and Sustainability.

Edited By: Wessex Institute of Technology (UK), Universidad Complutense (ES) and James Cook University (AUS)

2. Compagnon, R., Solar and daylight availability in the urban fabric, *Energy and Buildings* 36, 2004: p. 321–328.

3. Dillemath A., Roos B. White D. Integrating Solar Energy into Local Development Regulations. Solar briefing papers. <[www.planing.org/research/solar](http://www.planing.org/research/solar)>

4. Dipartimento del territorio - Repubblica e Cantone Ticino, 2007, Piano direttore: obiettivi pianificatori. Switzerland

5. C. S. Polo López, et al. Urban densification and energy performance of existing buildings: a case study, in CISBAT Conference: Future Buildings and Districts. 2015: Lausanne, Switzerland. p. 943-948.

6. D.G. Steyn. The calculation of view factors from fisheye-lens photographs, *Research note, Atmosphere-Ocean*, 1980:3, 1990: p. 254-258.

7. Neila González J.. *Arquitectura bioclimática en un entorno sostenible*. Ed. Munillalera, 2004, p. 440

8. Poul O. Fanger: *Thermal Comfort. Analysis and Applications in Environmental Engineering*. Krieger, Malabar, Fla. 1982,

9. EPBD recast, Directive 2010/31/EU of the European Parliament and of the Council of 19 May 2010 on the Energy Performance of Buildings. *Official Journal of the European Union*

10. IEA SHC Task 40, Net Zero Energy Solar Buildings, Project duration: October 2008—September 2013.

11. Lobaccaro G., Frontini F. Solar Energy in urban environment: how urban densification effect existing building. *Energy Procedia*, V. 48; 2014: p.1559 – 1569

12. Bonomo P., De Bernardis P., PV integration in minor historical centers: proposal of guide criteria in post-earthquake reconstruction planning. *Energy Procedia* V.48; 2014: p 1549–1558

13. Aste, N., Compostella, J., Mazzon, M., “Comparative energy and economic performance analysis of an electrochromic window and automated external venetian blind”, *Energy Procedia* V.30; 2012, 404 – 413

14. De Lieto Vollaro R., et al. Building energy performance analysis: A case study, *Energy and Buildings*, V.87, 2015, p 87–94



## Expanding Boundaries: Systems Thinking for the Built Environment

### TOWARDS INTEGRATED DESIGN STRATEGIES FOR IMPLEMENTING BIPV SYSTEMS INTO URBAN RENEWAL PROCESSES: FIRST CASE STUDY IN NEUCHÂTEL (SWITZERLAND)

S. Aguacil<sup>1\*</sup>, S. Lufkin<sup>1</sup>, E. Rey<sup>1</sup>

<sup>1</sup> Laboratory of Architecture and Sustainable Technologies (LAST), School of Architecture, Civil and Environmental Engineering (ENAC), Ecole Polytechnique Fédérale de Lausanne (EPFL), Switzerland

\*Corresponding author; e-mail: sergi.aguacil@epfl.ch

#### Abstract

In view of the importance of urban renewal processes, building-integrated photovoltaic (BIPV) systems can potentially provide a crucial response to the challenges of the energy turnaround. Functioning both as envelope material and electricity generator, they can simultaneously reduce the use of fossil fuels and greenhouse gases (GHG) emissions while providing savings in materials and electricity costs. These are precisely the objectives of most European energy directives, from zero- to positive-energy buildings. In Switzerland for instance, one way to achieve the objectives of the “Energy strategy 2050” is to install PV systems to cover 1/3 of the annual electricity demand. However, despite continuous technological and economic progress, the significant assets of BIPV remain broadly undervalued in the current practice. Various obstacles (technology choice, small volumes, lack of information and good examples, etc.) tend to increase the costs and reduce the acceptance of BIPV solutions. The present paper is an integral part of an interdisciplinary research project. Focusing on the architectural design issues, it presents the first results of a representative case study carried out in the city of Neuchâtel (Switzerland). The approach involves four main phases (Fig.1): (i) archetypes identification, (ii) building detailed analysis, (iii) development of architectural renewal design scenarios, and (iv) multi-criteria assessment of each scenario (energy consumption, electricity production, cost-effectiveness, and Life-Cycle Analysis). The application of the proposed approach on a case study allows us to initiate the first step towards a holistic and reliable multi-criteria comparison methodology for BIPV-adapted solutions in urban renewal design processes in the Swiss context.

#### Keywords:

Building-integrated photovoltaics; energy efficiency; renewable energy; sustainable architectural design; urban renewal; renovation strategy; multi-criteria assessment

## 1 INTRODUCTION

One of the top priorities of European countries is to reduce energy consumption and the GHG emissions in the built environment. Towards this aim, since the city of tomorrow is largely already built, many strategies stress the importance of urban renewal processes towards more sustainability in terms of economic, social and environmental impacts. Indeed, there are still huge potential energy savings to be made in European countries in general, and in Switzerland in particular. Most residential buildings were built

before 1985 and require large amounts of energy to ensure the minimum indoor thermal comfort [1]. In response, recent research works have started considering the large existing building stock, bringing to light the considerable importance of urban renewal strategies for the sustainability of the built environment in the next decades [2].

In parallel, one of the objectives of the “Energy strategy 2050” is to increase the use of renewable energy, and according to the International Energy Agency (IEA) it is possible to cover 1/3 of the annual Swiss demand for electricity using

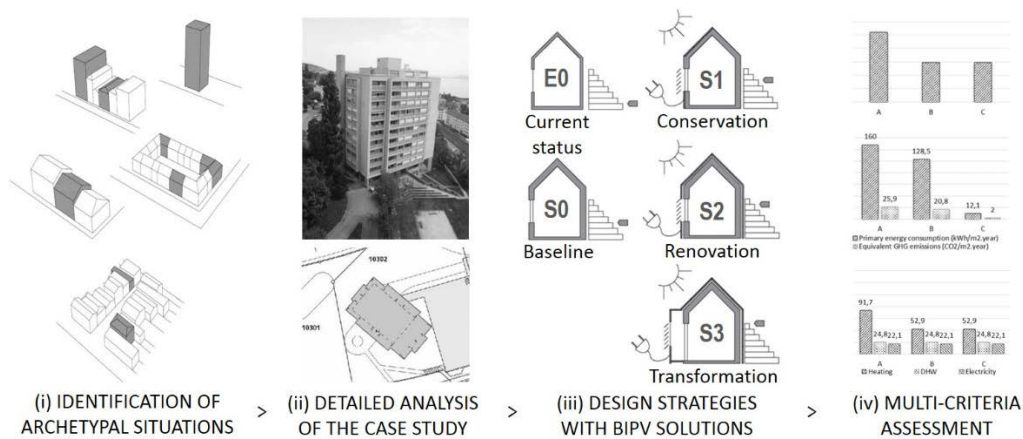

Fig. 1: Diagram of the proposed research methodology.

photovoltaic (PV) panels [3]. Such systems therefore provide a crucial response to the challenges of the energy turnaround [4].

BIPV is a growing and diverse area of research. In particular, it includes research on new products development, modelling, simulation, and assessment of their integration on buildings [5].

## 2 RESEARCH OBJECTIVES

Despite all this technological progress, only a small part of the available local potential for BIPV is valorised in urban areas (integration into roof and façades elements). Diverse types of obstacles limit a large-scale advanced PV integration into urban renewal processes. Most barriers are related to the limited motivation of architectural designers, a restricted knowledge of the BIPV potential and an insufficiency of aesthetically-convincing exemplary buildings [6].

To address this challenge, urban and architectural design towards increased integration – and therefore increased acceptance – could potentially provide a decisive solution. Although it remains largely disconnected from solar renewable energy issues, it represents a key element towards establishing a systematic link between BIPV and the necessary renewal of the considerable existing building stock.

Therefore, instead of considering BIPV as a technical constraint for designers, we propose a new approach based on the integration of BIPV solutions as a new “raw material” for architectural renewal projects [7,8]. By prioritizing architectural quality and dialogue with the built environment, it aims at identifying which construction elements can be substituted by the most appropriate PV components. The latter will not only fulfil the same requirements as other parts of the building envelope (water and air tightness, mechanical resistance, etc.), but also generate electricity on site from a renewable energy source.

Our work fall within an ambitious research project entitled ACTIVE INTERFACES [9] which is

currently being conducted in order to study in a structured and in-depth manner the technological, spatial, legal and socio-economic parameters related to the development of new adapted solutions, taking into account diverse criteria (energy consumption, electricity production, cost-effectiveness, and Life-Cycle Analysis). Crossing over the limits of current practices, this ongoing project aims at designing and assessing BIPV-adapted scenarios embodying different urban renewal strategies in the Swiss context through a multi-criteria assessment methodology.

The present paper is the first milestone on the road towards these integrated design strategies for implementing BIPV systems into urban renewal design processes. It presents the results from a first case study in Neuchâtel, based on the analysis and comparison of different architectural renewal design scenarios. The intermediary objective is to test, validate and find ways to improve the proposed methodology.

## 3 PROPOSED METHODOLOGY

The methodology involves four main phases (Fig.1): (i) identification of archetypes (residential buildings); (ii) analysis of the building (study of the current status and the thermal envelope’s construction details); (iii) development of three architectural renewal scenarios embodying different levels of intervention; (iv) multi-criteria assessment of each design scenario.

### 3.1 Identification of archetypes

We are focusing on Neuchâtel considering that it is representative of the typical middle-size city of the Swiss Plateau. Based on an urban analysis of its building stock, five residential archetypes were identified. The purpose is to select a representative building for each archetype to carry out a series of real case studies. These five archetypes were defined based on the following selection criteria (Fig.2), which are related to the opportunity to implement BIPV elements: i) construction period, ii) urban context (adjacent or

isolated building), iii) solar access potential on roof (sloped or flat), iv) façade (floors), v) heritage level of protection (protected, common or unattractive).

A - Construction period	before 1919	1919-1945	1946-1970	1971-1985	1986-2005
B - Urban context	Adj. / isolate	Isolated	Isolated	Isolated	Isolated
C - Roof potential	Sloped	Sloped	Sloped / Flat	Flat	Flat
D - Façade potential	1-4 floors	1-4 floors	1-4 floors	>7 floors	5-7 floors
E - Architectural quality (heritage)	Common II	Common II	Common II	Common II	Unattractive III
	Arch. 1	Arch. 2	Arch. 3	Arch. 4	Arch. 5

Fig. 2: Definition of five archetypes.

### 3.2 Detailed analysis of the case study

The building presented in this paper corresponds to the archetype 4 (Fig. 2). It is a typical residential building of the 70's, constructed at the beginning of the oil crisis (1972-1976) (Fig.3). Consequently, thermal considerations have had a rather small influence on the design of the envelope. It presents eleven-stories, consisting of 52 apartments and 5,263 m<sup>2</sup> of living floor area [10].



Fig. 3: Building image (current status).

A study of the construction details is crucial to detect all BIPV integration opportunities in the building envelope (roof and facades). In this case, façades are made with concrete prefabricated elements consisting of: 12cm of reinforced concrete, 4cm of expanded polystyrene (EPS) insulation, and an exterior facing concrete of varying thickness coated with a crushed stone agglomerate. Openings present double glazing and wood-metal frame. The flat roof is composed by 22cm of reinforced concrete, 6cm of EPS insulation, and 5cm of gravel. In terms of active systems, the building is connected to a central heating covering heating and domestic hot water (DHW) needs.

### 3.3 Design renewal scenarios description

Following the methodology (Fig.1), we defined five renewal scenarios from an architectural point of view. We started with the analysis of the **E0-Current status** scenario, which provides all the information about the building and reflects its

actual situation. The **S0-Baseline** scenario - without BIPV strategies- aims at achieving at least the current legal requirements defined by SIA 380/1 [11], in accordance with current practices. The last three design scenarios incorporate BIPV strategies and are defined as follows. **S1-Conservation**: aims to maintain the expression of the building while improving its energy performance (at least current legal requirements). **S2-Renovation**: has as purpose to maintain the general expressive lines of the building while reaching high energy performance (at least *Minergie* standard); **S3-Transformation**: best energy performance and maximum electricity production possible with aesthetic and formal coherence over the whole building (at least "2000WattsSociety" targets [12]).

### 3.4 Renovation strategies for each scenario

Following the architectural criteria defined in section 3.3, for **S0**, we propose to add an internal insulation and substitute the existing windows. For **S1**, in addition to the interventions of S0, we propose to cover the roof (250m<sup>2</sup>) and the railing of the windows (431m<sup>2</sup>) using BIPV elements, respecting the building's expression. For **S2**, we propose an external insulation façade system including the replacement of existing windows, and placing BIPV elements in the entire roof, the railing of windows and window surroundings (254m<sup>2</sup>), while maintaining the main lines of the building's expression. Finally, for **S3**, we propose a prefabricated façade element to plug-in directly on the existing façade, including insulation (ventilated facade), new windows and BIPV elements covering all opaque surfaces (514m<sup>2</sup>). The detailed visualization of the different scenarios for this first case study are detailed in [13].

### 3.5 Definition of assessment indicators

To carry out a multi-criteria evaluation of the design scenarios, four groups of indicators are defined. They assess and compare the scenarios' performances in terms of energy, economic and environmental aspects (Table.1). This preliminary definition will provide the basis for the more in-depth assessment in the future steps of the research project.

1-Energy consumption	
- Primary energy consumption	kWh/m <sup>2</sup> .y
- Equivalent GHG emissions	kgCO <sub>2</sub> /m <sup>2</sup> .y
2-Photovoltaic installation	
- Electricity production	MWh/year
- Self-consumption potential	%
3-Cost-effectiveness	
- Annual rent increase	%
- Accumulated global cost	CHF
4-LCA - Life Cycle Analysis	
- Embodied energy balance	MJ/ m <sup>2</sup> .y
- Global Warming Potential	kgCO <sub>2</sub> / m <sup>2</sup> .y

Table. 1: Assessment indicators.

## 4 SIMULATION

The tool used to estimate the assessment criteria related to energy consumption, emissions and photovoltaic production is *DesignBuilder*, based on the *EnergyPlus* simulation engine [14]. For the cost estimation we used the EPIQR tool [15], developed for testing different renewal scenarios and identifying the best performing one(s).

### 4.1 Input data for energy consumption

The U-values for the current status -scenario E0- are defined through a detailed analysis of the existing envelope [16]. For scenarios S0 and S1, U-values target corresponds to SIA 380/1 requirements, and for scenarios S2 and S3 they are the result of the construction detail proposition (Table.2).

Scenario	E0	S0	S1	S2	S3
Façade	0.9	0.2	0.2	0.1	0.1
Roof	1.3	0.2	0.2	0.2	0.2
Glazing	2.6	1.3	1.3	1.1	0.8
Vent. r/h	2.0	2.0	1.0	0.5	0.5

Table. 2: U-value ( $W/m^2K$ ) and ventilation ratio.

### 4.2 Input data for photovoltaic installation

The choice of the BIPV components to be used in scenarios S1, S2 and S3 responds to the will of carrying out a rehabilitation which preserves the architectural quality of the building, while compromising as little as possible the level of electricity produced. We have chosen standard panels for the roof [17] and BIPV customized elements with frameless panels for the façade [18]. Based on the monocrystalline (sc-Si) technology of cells, an efficiency of 14% is estimated [19]. The cost is estimated between 245 and 445 CHF/m<sup>2</sup>, including inverters, wiring and accessories [20].

### 4.3 Input data for global cost-effectiveness

One of the main concerns about BIPV installations is related to the economic and financial aspects. Therefore, the precise evaluation of the costs is an essential aspect of the proposed methodology. The estimation of the accumulated cost due to energy consumption is calculated obtaining the cost-effectiveness for each scenario, using energy cost savings and extra revenues from the sale of PV electricity produced (Fig.7). This method is recommended by the cost-optimal methodology applied to renewal processes [21], considering medium- or long-term investment scenarios. For this case, we have considered a horizon of 50 years (lifespan), 3% of interest rate and 1% increasing energy price per year [1].

## 5 RESULTS

### 5.1 Energy consumption

The heating need target set by the SIA 380/1 for housing, considering an envelope area ( $A_{th}$ ) of 3,922 m<sup>2</sup> and a floor area ( $A_E$ ) of 5,263m<sup>2</sup> is 38 kWh/m<sup>2</sup>-year. The target is achieved for the four

scenarios, corresponding to a 53% saving on the heating demand. In terms of non-renewable primary energy consumption, scenarios achieve, with respect to E0; -31%(S0), -61%(S1), -78%(S2) and -89%(S3) (Fig.4). To convert the results from final to primary energy and CO<sub>2</sub> equivalent emissions, we have used coefficients from SIA 380/1 [12]. For electricity: 2.970 kWh<sub>PE</sub>/kWh<sub>FE</sub> and 0.154 kgCO<sub>2eq</sub>/kWh<sub>FP</sub> electricity); for oil heating 1.690 kWh<sub>PE</sub>/kWh<sub>FE</sub> and 0.403 kgCO<sub>2eq</sub>/kWh<sub>FP</sub>.

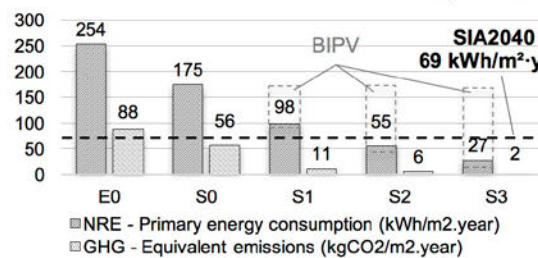

Fig. 4 Net energy consumption and emissions.

The values obtained for the current situation far exceed the Swiss target value set by SIA2040 based on the "2000WattsSociety" [13], which in this case sets the limit of consumption to 69 kWh/m<sup>2</sup> per year (for electricity, heating and DHW) (Fig.4). These results show the changes needed to achieve the goals set by the "EnergyStrategy2050" and highlight the importance of strategies to promote urban renewal processes. To achieve this targets, it is crucial to propose mixed strategies composed by passive and active measures to take into account the origin of each energy source. For this reason, we have proposed, in addition to the envelope renovation, a modification of HVAC systems for the scenarios S1, S2 and S3, replacing the existing oil boiler by an air-water heat-pump to increase the self-consumption potential and reduce energy consumption of heating and DHW.

### 5.2 Photovoltaic installation

Concerning the BIPV strategy implemented in scenarios S1, S2 and S3, the estimated production of the installation is 75 (S1), 128 (S2) and 174 (S3) MWh/year. In terms of electricity annual coverage ratio, it represents 16% (S1), 33% (S2) and 48% (S3) of the domestic electricity consumption, taking into account the implementation of a new heat-pump to cover all heating needs. The results have been obtained through hourly simulations during a representative year (Fig.5).

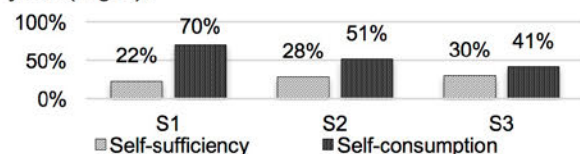

Fig. 5: Self-consumption potential.

### 5.3 Global cost-effectiveness

The global costs of renewal scenarios correspond to 1,004,400 (S0), 1,403,992 (S1), 1,995,252 (S2)



and 2,763,750 (S3) CHF. The difference lies in the different passive strategies and the BIPV elements. We have estimated the repercussion of the renovation cost on the price of annual rent, as compared with the average value of the rent in the region of Neuchâtel, estimated at 220 CHF/m<sup>2</sup>·year [1]. In this case three different thresholds are analysed: 3% for minimum profitability, 4.5% for average profitability and 6% for significant profitability (Fig.6).

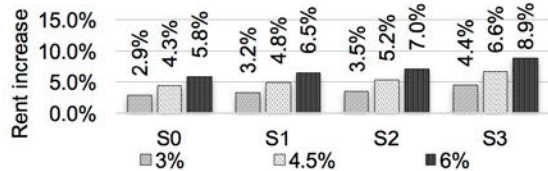

Fig. 6: Annual rent increase.

To estimate the global cost-effectiveness, we used energy savings and electricity production (including 0.8% of decreasing production per year according to the guaranteed performance of PV elements [17]), taking into account the sale and purchase price of electricity 0.2 CHF/kWh and 0.1 CHF/kWh for heating oil, tax included.

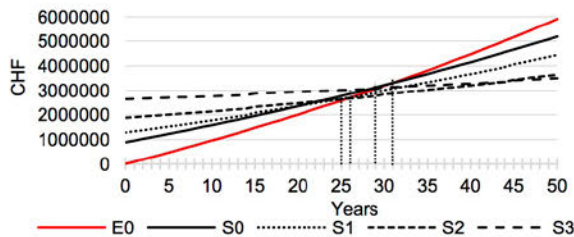

Fig. 7: Accumulated cost.

Through the accumulated cost due to energy consumption (Fig.7) we represent graphically the performance of each scenario. Financial aid to tackle the investment corresponds to 30% of the PV installation cost [22]. Using these data, and taking into account maintenance and repair-replacements costs [23] for the BIPV installation, the payback time of each scenario has been calculated using the DCF (discounted cash-flow) methodology by net present value (NPV), leading to 31 (S0), 26 (S1), 25 (S2) and 29 (S3) years, taking into account the real self-consumption with no-battery systems (electricity production consumed on-site by the building). The BIPV strategy thus presents a shorter payback time thanks to the extra revenue generated by the produced electricity.

#### 5.4 Life-Cycle Assessment (LCA)

The results of the Life-Cycle Assessment of each renovation scenario shows that scenarios S2 and S3 respect the Swiss targets, both in terms of embodied energy (Fig.8) and GHG emission (Fig.9) thanks to the change in the type of energy source and the low-emissions renovation materials proposed (for S2 and S3). Calculations have been done with the ECO-BAT application taking into account a service life of 30 years (PV),

20 years (HVAC systems) and 40 years (construction materials) [24].

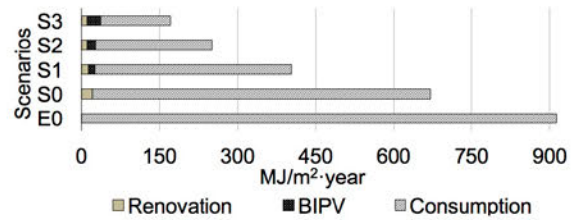

Fig. 8: Embodied energy balance (MJ/m<sup>2</sup>·y).

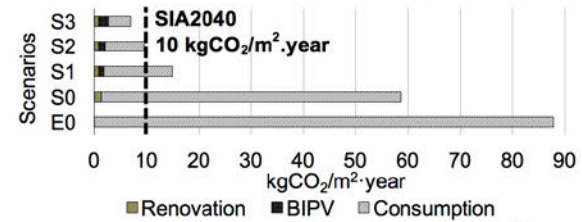

Fig. 9: Global Warming Potential (kgCO<sub>2</sub>/m<sup>2</sup>·y).

## 6 CONCLUSION

Based on the results of the evaluation, it seems clear that energy renovation projects without the integration of renewable energy in general and BIPV in particular are no longer an option if we want to achieve the objectives of the “Energy strategy 2050”. Today, renovation projects improving the building envelope with a very high level of thermal energy performance are necessary, but not sufficient. Compensating buildings’ energy consumption by producing electricity on site has become the number one priority. In this sense, by proposing new adapted BIPV solutions for urban renewal processes, the research contributes to advancing architectural and construction design practices in this direction. At an early stage of the research, the results of this preliminary application case study highlight several interesting elements, such as the best cost-effectiveness of the BIPV scenario. By taking into account a simple passive strategy, 31% (interior insulation) and 61% (exterior insulation) savings of heating are achieved. As we can see in this first case study, we can achieve more than 89% of total savings by introducing mixed strategies (passive, active and renewable energy systems) (Fig.4). Economic aspects, in particular, appear as key elements to understand obstacles and find ways for getting around them. As such, the type of financing is an essential issue and will require specific attention in the future development of the project.

This study also allows a first validation of the proposed methodology and opens up new perspectives for the upcoming process of finalization and refinement. Finally, after these various refinements will have been carried out, further phases of the research will consist in applying the methodology to other archetypal buildings. These upcoming case studies will ensure the validation of the finalized methodology

and enable the extrapolation of the most performing BIPV renovation strategies at the urban scale. Moreover, these case studies will provide architects, installers and public authorities with a catalogue of innovative and adapted “best practice” solutions for a large-scale advanced BIPV integration into urban renewal processes.

## 7 ACKNOWLEDGMENTS

The Active Interfaces research project is part of the National Research Program "Energy Turnaround" (NRP 70) of the Swiss National Science Foundation (SNSF). Further information on the National Research Program can be found at [www.nrp70.ch](http://www.nrp70.ch). The authors also thank the Ecole Polytechnique Fédérale de Lausanne (EPFL) for their support.

## 8 REFERENCES

- Office fédéral de la statistique. (2015). Neuchâtel.
- Riera Pérez M., Rey E. (2013). A multi-criteria approach to compare urban renewal scenarios for an existing neighbourhood. Case study in Lausanne (Switzerland). *Building and Environment*, 65(2013), 58-70.
- IEA (International energy agency). (2002). Potential for Building Integrated Photovoltaics, Report PVPS T7-4. Switzerland.
- SFOE. (2014) Energy Strategy 2050. Zurich.
- Frontini, F. et al. (2012). A case study of solar technologies adoption: criteria for BIPV integration in sensitive built environment. *Energy Procedia*, 30(2000), 1006-1015.
- Heinstein P., Ballif C., Perret-Aebi L.E. (2013). Building Integrated Photovoltaics (BIPV): Review, Potentials, Barriers and Myths. *Green*, 3(2), 125-156.
- Aiulfi D., Rey E. (2010). Les technologies vertes, matières premières pour la créativité des architectes. Neuchâtel: MICRO 10, specialized lectures.
- Rey E. (2014) From Spatial Development to Detail. Collection Notatio. Lucerne: Quart Publishers
- Rey E. et al. (2015), Building integrated photovoltaics. ACTIVE INTERFACES, NRP 70(Energy Turnaround) and NRP 71 (Managing Energy Consumption), Kick-off Meeting Luzern, 24 April
- Bauer F., Oswald D., Trachsel C., Rey E. (2013) HOLISTIC: Retour d'expériences. Public Final Report. Neuchâtel: CONCERTO Program.
- SIA (2009). SIA 380/1:2009 L'énergie thermique dans le bâtiment. Zurich.
- SIA (2011). SIA 2040: La voie SIA vers l'efficacité énergétique. Zurich.
- Aguacil S., Lufkin S., Rey E. (2016). Architectural design scenarios with building-integrated photovoltaic solutions in renovation processes: Case study in Neuchâtel (Switzerland) (Switzerland). PLEA 2016, Los Angeles, USA.
- DesignBuilder (2015), Retrieved April 23, 2015, [www.designbuilder.co.uk](http://www.designbuilder.co.uk).
- Flourentzou F., Droutsas K., Wittchen K.B. (2000), EPIQR software. *Energy and Buildings*, 31(2000), 129-136.
- Bauart (2015). Stratégie d'intervention sur les Immeubles Troncs 12-14. Neuchâtel.
- Meyer Burguer (2016). MegaSlate PV panels, Retrieved April 25, 2016, from <http://energysystems.meyerburger.com/>.
- CSEM (2015). Selective filter technology to coloured solar modules, from [www.csem.ch](http://www.csem.ch).
- Cerón I., Caamaño-Martín E., Neila F.J. (2013) 'State-of-the-art' of building integrated photovoltaic products. *Renewable Energy*, 58(0)127-133.
- Solar-toolbox. (2015). Retrieved January 10, 2016, from [www.solar-toolbox.ch](http://www.solar-toolbox.ch).
- BPIE (2013). Implementing the cost-optimal methodology in EU Countries. Brussels.
- Swissgrid. (2015). Retrieved April 23, 2015, from [www.swissgrid.ch](http://www.swissgrid.ch).
- NREL (2003). Guidelines for the Economic Evaluation of Building Integrated Photovoltaics Power Systems. Colorado.
- ECO-BAT (2016), Retrieved January 13, 2016, from [www.eco-bat.ch](http://www.eco-bat.ch)



## Expanding Boundaries: Systems Thinking for the Built Environment

### FROM DESIGN TO OPERATION – LESSONS LEARNED FROM THE WORLD'S FIRST PASSIVE-HOUSE OFFICE TOWER

C. Steininger<sup>1</sup>, R. Toth<sup>1\*</sup>

<sup>1</sup> Vasko + Partner Ingenieure, Grinzinger Allee 3, 1190 Wien, Austria

\*Corresponding author; e-mail: r.toth@vasko-partner.at

#### Abstract

The RHW.2-tower in Vienna is the world's first office tower certified to the Passive-House-Standard. In operation since the end of 2012, the building was designed to fulfil the highest standards in terms of energy-efficiency and user satisfaction.

The building's design was based on two principles. The first was the consequent reduction of energy demand. This was reached through the use of energy-efficient equipment, a focus on reduction of standby-losses, a strictly demand-driven approach for the operation of all installations and a special attention in creating a superior building envelope with a low air-leakage rate. The second was to integrate several energy sources with a special attention to those given on-site. The system includes a biogas-fuelled CHP, geothermal probes within the buildings slurry trench walls, the use of the waste heat of a neighbouring data-centre and cooling with the water of the nearby Danube Canal. To be able to optimize the energy performance of the building during operation and to build a data foundation for further research and development, a comprehensive energy monitoring system was installed. The collected energy performance data of the first two years of operation prove the outstanding energy performance of the building. Nevertheless, the energy monitoring systems also enables the user and operator to identify areas for further optimization.

The paper shows the challenges and difficulties from the first steps of design to the actual operation of a highly energy efficient building like the RHW.2. In addition, the results of the first phase of the energy monitoring as well as the challenges faced in the first two years of operation shall be discussed.

#### Keywords:

large-scale Passive House; energy efficiency; energy monitoring

## 1 INTRODUCTION

In December 2012 construction of the world's first office high riser certified to the Passive-House-Standard was finished in Vienna, Austria. Located alongside the Danube Canal in the centre of the city, the goal of this building was from the very beginning to realize an energy-efficient model-building which fulfils the highest standards in terms of energy consumption as well as user satisfaction.

To meet these goals, it was necessary from the first steps of the design phase to include all disciplines in an integrated approach to find an energy optimized solution for the buildings construction and its installations. The building was designed to use the resources of the given

location as efficiently as possible. An elaborate mix of different energy supply systems was also crucial within this concept, as the use of only one main energy source or technology to satisfy the special demands within buildings of this size is leading nowhere.

After overcoming all the challenges faced in the design and construction phase of complex large-scale buildings, the operational phase poses a huge amount of new difficulties on the way to energy efficient operation. In the end the energy consumption of the construction depends in large parts on the use of the building and the behaviour of the people working in there every day. Besides the user, it is especially the facility service provider (FSP) whose task it is, to keep an eye on the

energy efficient operational mode of the building and fill the ideas of the design engineers with life.

In this paper in a first part, the building technological concept of the world's first high rise office building, which is certified to the passive-house standard, will be explained. A special focus lies on the discussion of the special challenges within the different stages of planning and construction an edifice with sharply increased standards in terms of energy demand and comfort. In a second part, the findings of the analysis of the energy consumption data of the building within the first two years of operation will be discussed against the background of high user demands with the need for energy efficiency at the same time. The energy consumption data is taken from the comprehensive energy monitoring system which was installed in the RHW.2 in order to be able to optimize the buildings installations during the operational phase.

## 2 DESIGN AND CONSTRUCTION

### 2.1 The technological concept

As already mentioned in the beginning, the design and construction phase of this building was characterised by an integrated approach in which all disciplines were involved and mutual interdependencies were taken into account in finding the ideal solution for the building's design. As an example, a design process, where architecture works independently from building technology and vice versa building technology works independently from architecture, leads inevitably to shortcomings in fulfilling the goal of designing an energy efficient model building. The construction has to be seen as one aggregate functional unit, which consists of several sub-units. The goals which are defined at the start of the planning process can only be achieved, when these sub-units are coordinated with each other

and are able to form a functioning system in the end.

One major outcome of this process was the special double-façade system which was designed and built for this building. In order to reduce cooling and heating load and therefore reduce the towers energy demand, the façade consists of two layers. The outer hull is made up of laminated safety glass-elements which define the contour of the building. The inner façade is being made up of massive concrete parapets with upgraded insulation and window strips with passive-house qualified window elements. The ventilation of the space between the two façade-layers is ensured by ventilation-fins located per floor around the whole length of the cladding. This fact is insofar important as it prevents the overheating of the interspace between the two layers in hot summer days. One benefit of this system is that it allows the use of outside shading devices, which are installed in the interspace between inner and outer layer. The outer layer works here as a wind shield and allows the screens to be used even in extremely windy conditions without any problems. Another benefit is the improvement in comfort for the office-workers, as the wind protection given through the outside layer, opening of the windows and thus natural ventilation of the rooms behind is possible.

Another cornerstone of the buildings technological concept is the integration of several energy sources in a complex system of energy generation and distribution (Fig. 1). The heart of this system is a biogas fuelled combined heating and power plant (CHP), which provides – based on the principle of trigeneration – heating energy for warming the building on cold winter days. When outside temperatures are rising and heating demand decreases, the excess heating energy is used – via an absorption cooling machine – to cover the cooling demand of the construction. The thermal output of the CHP is 450kW, while the

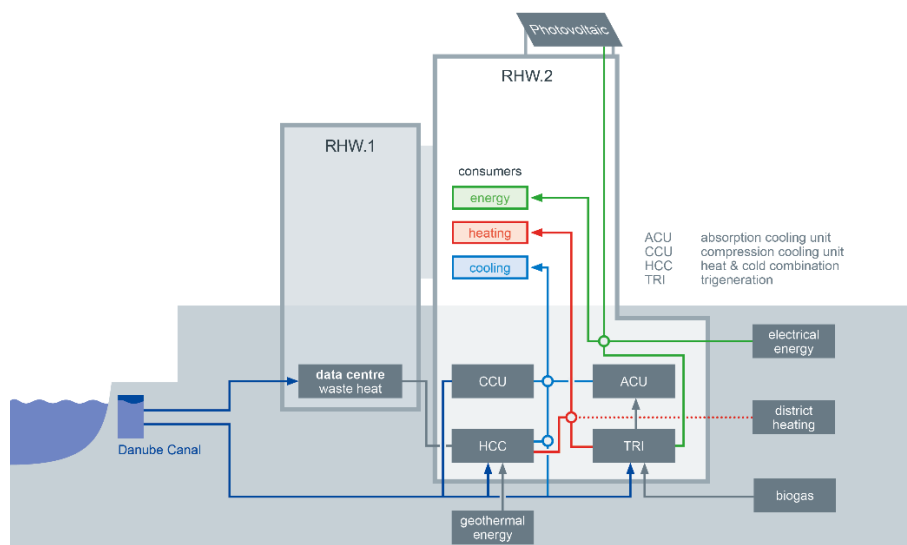

Fig. 1: Design concept of RHW.2.

electrical output is 400kW. While the output of thermal energy is used to provide the necessary cooling and heating energy for the office tower, the generated electrical energy is – certified as green electricity – fed directly into the public power grid.

Another energy source used is geothermal energy. For that geothermal probes have been included in the buildings deep reaching slurry trench walls. With a highly efficient compression chiller, which operates – in line with actual demand – as a cooling machine or a heat pump, additional thermal energy for the supply of the office building can be provided. To cover the peak demand on very hot summer days, a second energetic optimized compression chiller has been installed, which is re-cooled by the water of the nearby Danube-Canal. In times, when the water of the river is cold enough, it can be used for direct cooling too.

Another heat source incorporated in the supply system of the building is a data-centre, which is located in a nearby building. Normally the waste heat of the IT-equipment is lost. In this case it is ecologically worthwhile used for providing heat energy to the office building.

The whole system of energy generation and distribution is controlled through an integrated control system, which links all the different installations at a common point and processes all the data from the various appliances at a central location. Only with the existence of such a comprehensive and integrated system it is possible to operate complex buildings like the RHW.2 in an efficient way.

To decrease the energy demand of the building significantly – which was required to fulfil the Passive-House requirements – it was necessary to optimise all the installations and processes already in the design phase. Due to the limit of space in this paper only two examples shall be discussed here.

The first is the ventilation system, which are in general among the main energy consumers in large-scale buildings [1]. To optimize working hours, the ventilation was divided in an outer (office spaces) and an inner zone (sanitary facilities, secondary rooms, corridors). On days with moderate temperatures building occupants can use their operable windows for natural ventilation, while the mechanical ventilation system is reduced as much as possible. The amount of inlet air is adjusted as a function of indoor air quality. Beyond office hours (night, weekend) the ventilation plant is put out of operation or the air flow limited as far as possible. Besides the optimization of large-scale installations like the ventilation system a lot of effort in the design phase was put into the reduction of the standby-power-consumption of the construction. Standby-consumption is the

amount of energy which is consumed outside the operating hours of the construction and in most buildings makes up for a large part of the overall energy consumption [2].

To reduce this amount of ‘grey energy’ in RHW.2 a special focus was put into small scale consumers which can be found in huge numbers in large buildings (like electronic ballasts, thermoelectric drives, bus modules etc.). Although – seen individually – this small-scale equipment’s power consumption is very low (normally several Watts), in sum they compose a large amount of the buildings standby-power-losses, solely because of their amount. The electronic ballast of standard office luminaire for example, consumes 1W even when switched off. In the example of the passive office building in Vienna, about 6.000 light fixtures have been installed, which means that only the ballasts add up to a standby-loss of 6kW. To reduce the energy consumption of these devices simple switching mechanisms have been included in the electrical design, which automatically shut off power supply for these devices outside office hours.

To sum it up, in RHW.2 a technological concept which was based on the conditions on the given site, the consequent use of highly energy efficient technologies, a focus on demand driven design of the installations and an integrated control system led to a building design which should lead to significant reduction in energy consumption compared to conventional office buildings.

## 2.2 The construction phase

The construction of a highly energy efficient large-scale building raises several special challenges, which may be not that important in raising conventional buildings, but are crucial for the success of complex, energy-efficient projects.

One of these challenges is to raise awareness for the special character of the building and to link all the different disciplines and companies engaged in the construction process, so they take care of interdependencies and understand that the goals of the project can only be met when all subsystems work together seamless. Just as it was necessary in the design phase for architects, building physics and building engineers to work together and take into account interdependencies between the different fields, this mutual approach is an essential prerequisite too, when it comes to building an energy efficient model office tower. Furthermore, the comprehension to use new technologies and designs instead of old and maybe well-tried concepts is normally not very distinct among the people and companies involved in the construction process. In the case discussed in this article, increasing this understanding was a main and often troublesome task at the very beginning of construction.

Another challenge is the supervision of a high-quality execution of construction work. Large-

scale buildings, which are intended to fulfil the passive-house standard, e.g. the impermeableness of the building hull is a crucial factor. Therefore it is necessary to monitor the diligent execution of previously specified implementation details in every phase of the construction process (e.g. leakproof building of façade junctions) very thoroughly. Besides quality control of the construction work, it is moreover necessary to check the selection of the installed products. Energy efficient devices are usually more expensive than conventional devices, what provides economically oriented construction companies an incentive to use conventional instead of efficient technology.

### 3 RESULTS

#### 3.1 Key figures from the energy monitoring system

The RHW.2 was equipped with a comprehensive energy monitoring system, which allows a detailed analysis of the buildings energy flows and provides a rich database for the analysis of the function of the different energy efficiency measures included in this construction. For that over 650 meters for electrical energy, heating/cooling energy and water have been installed on the basis of a detailed metering concept. All in all, over 1,000 data points were defined and are being processed within this system.

After more than two years of full operation the first findings from the performance analysis of the building can be presented. The data is taken from the first full year of operation in 2014. To make comparisons with other buildings possible, the performance figures were referenced to the gross floor area (GFA) of the building.

Macro data, which means gross energy efficiency figures, confirm that the design concept is working and led to a significant lower energy consumption. The electrical energy consumption in 2014 was 69.2 kWh/m<sup>2</sup>, the heating demand 30.1 kWh/m<sup>2</sup> and the cooling consumption 39.5 kWh/m<sup>2</sup> (see Fig. 2). In this figures all energy consumers in the building (office, kitchen, restaurant, conference, general areas) are included. In relation with the figures of other office towers which were analysed in different reports, these numbers are significantly lower. [3] (see Fig. 3)

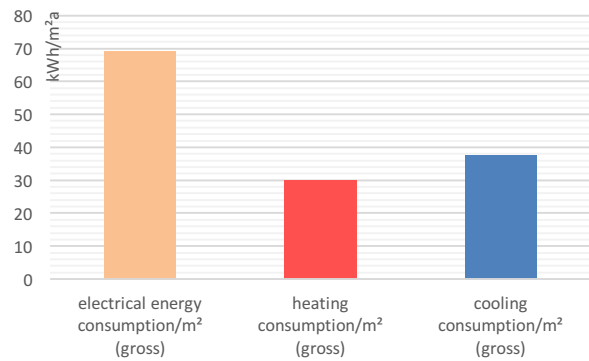

Fig. 2: Overall energy consumption RHW.2.

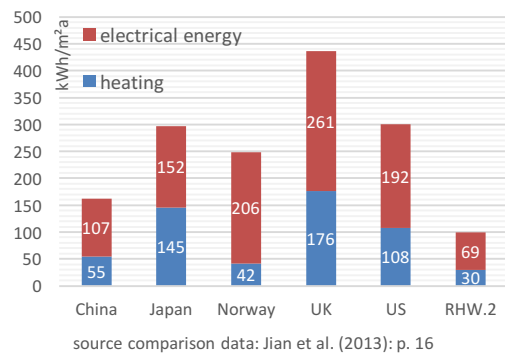

Fig. 3: Comparison energy demand office buildings.

When analysing the energy consumption figures of the RHW.2 building it has to be taken into account, that the building is used as the headquarter of a bank and therefore the user has very high standards and expectations for indoor air temperatures and humidity, which means that the air-condition and ventilation plants have to be operated within very narrow setpoint value windows. Lesser strict standards for indoor air quality would lead to a significant reduction in energy consumption.

Though the RHW.2 building was designed and constructed as a Passive House, the air-conditioning system was able to provide comfortable indoor climate conditions for the user on extremely hot summer days as well as on cold winter days. That shows that energy efficient buildings can be as comfortable as other buildings and the fear of a lot of people that energy efficiency means less occupant comfort can be disproved. On the contrary the example of the RHW.2 shows, that the user highly appreciates the benefits of the energy efficient design like operable windows or the fanless cooling system via concrete core activation.

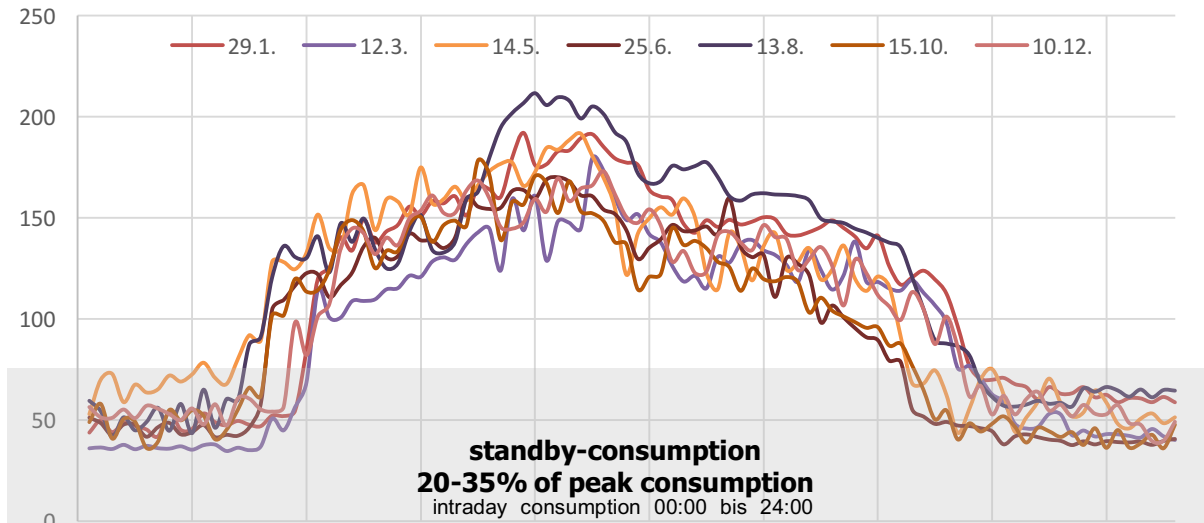

Fig. 4: Power consumption on selected days.

### 3.2 Potentials for optimisation

Although the gross energy efficiency figures of the given building are very good compared to average buildings, an in-depth analysis of the energy data reveals that there is still a lot of potential for further optimisation and reduction of energy consumption.

Especially in the area of standby-consumption further optimisations are needed to reduce the share of 'grey-energy'. As Fig. 4 shows, although several measures have been taken to reduce the loads outside office hours, the share of standby-power was still 20-35% of the peak-power of the building.

A closer look on the data from the energy monitoring shows, that standby-consumption was mainly caused by an inefficient operational mode of the cooling system in the first phase of operation. Due to the complexity of the system in this initial period the integration of the different energy generators and the demand driven operational mode were still not working as efficient as they could do.

This analysis does not only show the potential for further optimisation, it also shows the importance of comprehensive energy monitoring systems for energetic optimization of large-scale buildings. An in-depth examination of energy flows can only be done if there is enough detailed data available to analyse all systems and their sub-systems separately. Gross figures are definitely not enough for this task.

The example of the RHW.2 also shows that the investment needed for energy monitoring systems can pay back in a very short time, because of the value of this system for optimisation of energy consumption and reducing energy bills for the owner. Especially in the first months of operation the meter data was a valuable source for finding

problems in the buildings installations, which probably would have never been found without these data available.

### 4 SUMMARY

With this brief presentation of the main challenges and findings of designing and operation a highly energy efficient building like the RHW.2, it was shown that the consequent implementation of an energy efficient design can reduce the energy demand of office building significantly.

The given example also shows that the complexity of the realisation of new concepts for energy efficient building design shouldn't be underestimated. Complex buildings call for a higher degree of supervision not only in the conception- and construction-phase but also during the first years of operation.

For a successful transition from construction to operation it is necessary, that the persons involved in the building's design are also included in the first operational period. The facility service providers often lack the detailed technical knowledge needed for dealing with the challenges that arise in the first operational months and years in complex buildings. An involvement of the building engineers, responsible for the idea of the buildings concept, can lead to better results and a smoother transition from construction to operation.

For building owners it is very important to understand that the energy consumption of the building largely depends on the way how the building is used. The best building design can lead to disproportional energy consumption figures if installations are operated in modes they are not designed for or failures in the systems (e.g. because of wrong setpoints) are not noticed or neglected.

## 5 REFERENCES

1. Bundesamt für Energie BFE, Energieverbrauch von Bürogebäuden und Großverteilern, Erhebung des Strom- und Wärmeverbrauchs, der Verbrauchsanteile, der Entwicklung in den letzten 10 Jahren und Identifizierung der Optimierungspotentiale. 2010, Bern.
2. Hong, Tianzhen et al. (2013): Building Energy Monitoring and Analysis. Lawrence Berkeley National Laboratory. June 2013.
3. Jiang, Yi et al. (2013): Volume III – Case Study Buildings. In: Institute for Building Environment and Energy Conservation (Hg.): Total Energy Use in Buildings. Analysis and Evaluation Methods. Tokyo. 2013





## Expanding Boundaries: Systems Thinking for the Built Environment

### AN INTEGRATED AND INTELLIGENT WAY TOWARDS ENERGY MANAGEMENT- THE COCKPIT

S. Lee<sup>1</sup>, K. Shah<sup>1</sup>, J. Yang<sup>1\*</sup>, C. Deb<sup>1</sup>

<sup>1</sup> National University of Singapore, 4 Architecture Drive, Singapore

\*Corresponding author; e-mail: bdgyj@nus.edu.sg

#### Abstract

In an increasingly competitive environment, a highly efficient energy management system is of utmost importance. However, despite the research on energy saving methodology and retrofitting analysis, these results and data do not allow different users to focus on what lies inside the management and strategy level. The Cockpit concept emerges as a strategic management system, in near real time, as an attempt to explain and communicate the institutes' energy performance at different levels. With respect to the detailed energy data analysis, it helps in the understanding and visualization of the institutional building energy performance. In addition, the Energy cockpit display interface presented in this study is an essential feature for the integrated energy study. Energy consumption and comparison as well as the different security levels provided, are able to give relevant and critical information for the building developers, owners, occupants, as well as visitors.

#### Keywords:

Energy management; Cockpit; Energy efficiency; Data analysis

### 1 INTRODUCTION

Energy is nowadays one of the most challenging sectors because of the rise in prices and the diminution of the energy sources. The impact of the building sector on the energy consumption is even enormous: 40% of the overall energy consumption in Europe [1] and around 30–40% of the world primary energy consumption [2]. Studies have shown that there is a significant potential to reduce energy consumption of 20% [3] and in GHG emissions of 30% [4]. However, to achieve these potential reductions some strategies in energy management are needed [5,6]. Hence, a lot of research studies have been recently focused on energy optimisation [7,8] through different energy management systems [9].

The Cockpit concept emerges as a strategic energy management system in recent time, with the advantages of being able to explain and communicate the energy performance at different levels within an organization or a specified scope. While it can be considered almost absolutely eco-friendly during the operational phase, it is important to evaluate the energy in a visualization

way to give relevant and critical information for the building developers, owners, occupants, as well as visitors. In a thorough literature review, it is found that a comprehensive energy cockpit development involving the energy consumed from the data collecting, data cleaning, until usage by the systems of the buildings and the energy data analysis is very limited.

On the other hand, with the rapid development of sensor/meter technology and the installation in building sectors, network and transmission technology and cloud computing, large amounts of energy consumption data is being generated and has been accumulated in several subsystems of a building [10]. To better make use of this data and also better deal with these data challenges, real time cockpit energy data analytics provide new opportunities by achieving integrated and intelligent energy management.

The following paper presents a smart development of energy monitoring cockpit, which is able to perform automated data cleaning to reduce labour cost, and describes smart automation tools which are able to identify energy saving opportunities, hence meeting the

requirements and dealing with the challenges as described above.

## 2 COCKPIT DEVELOPMENT

### 2.1 Energy Information Network (EIN) Infrastructure

The EIN takes National University of Singapore (NUS) campus as a living lab, with the first phase to include 10 buildings to be instrumented an integrated with an energy and environment monitoring and management system so that each building can be communicated with a centralized and monitored Energy Cockpit.

The “Energy Cockpit” is located in the Department of Building. Energy analytics will be used to monitor and manage the performance of these buildings with a goal of reducing energy consumption. This will help determine any discrepancies between benchmarked performance and actual energy usage thereby unlocking energy savings opportunities and identifying areas for improvement or energy efficient upgrades.

### 2.2 Data Cleaning

Figure 1 shows the potential errors in data, such as outliers, missing values and time stamp issues, which can happen with any data collection system any time randomly, sometimes for no reason. In the energy consumption data collecting system in NUS, more than 5000 errors occurred in one month only for one random building. Although it is possible to spot and correct them by those people with an intimate understanding of the building’s functions and usage on a daily basis. The required resources, time and financing, are the main challenges the energy management system faces.

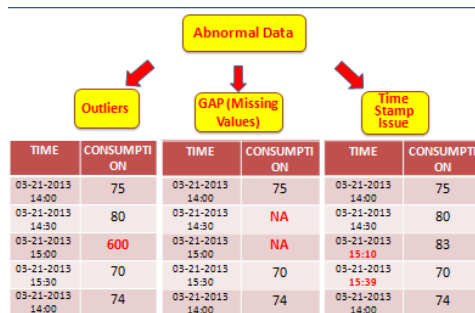

Fig 1: Potential errors in data.

Since the energy consumption data collected is the basis for any data analysis and monitoring, the Cockpit runs a data cleaning methodology in the background to provide the clean data. The methodology involves a K-means clustering approach and data imputation using linear regression with a past five hour input to detect the outliers. The size of the resulting clusters is further analysed into key factors to identify groups of energy consumption so as to observe the outlier that are distinct from the majority of the

data. The whole process is applied automatically to provide a clean data set for future research purposes.

Figure 2 is the dashboard of the Cockpit data collection and cleaning status. The green light in the last column shows the smooth data collection with no error currently. The total number of missing data imputed, timestamp issue data and the outliers identified through the automatic data cleaning process are shown in column 4,5 and 6 respectively.

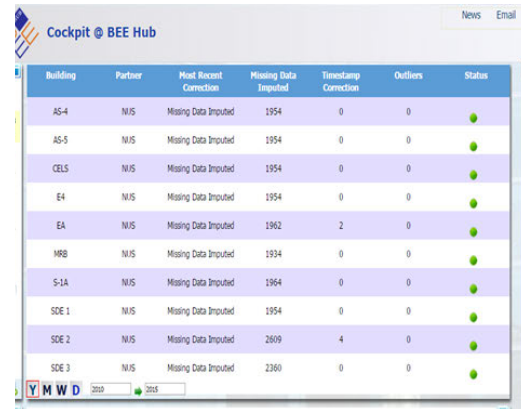

Fig 2: Data collection and data cleaning tool.

### 2.3 Energy Monitoring

The cockpit consists of three main parts for an integrated and intelligent energy management.

The first part is the energy monitoring. The key data for each building is shown, including gross floor area, building category, age of building, operating hours, occupancy per square meter as well as the EUI for the past 12 months and the chiller plant efficiency. Then energy consumption of the Air-conditioning part, electrical part and the total energy consumption part are monitored simultaneously. It is also possible for the users to choose the shown time period at the bottom left so that the data can be shown on a yearly basis (y), monthly basis (m), weekly basis (w) or daily basis (d) as shown in figure 3.

A comparison of energy consumption is also possible for up to 4 buildings as showing in figure 4. This comparison is a way of indicating the different pattern of energy consumption, and also bring opportunities to look into operational efficiency and cost control [11], system stability and reliability [12], as well as energy efficiency and environmental issues [13].

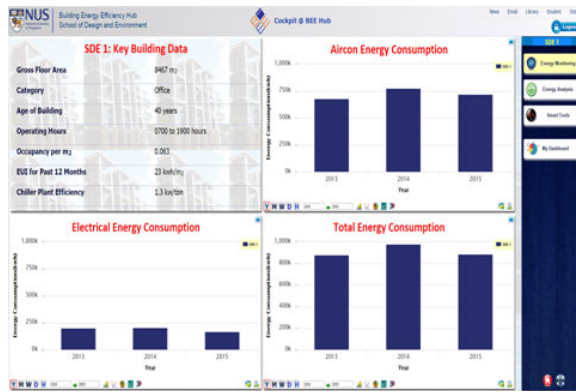

Fig 3: Energy monitoring interface with single building.



Fig 4: Energy monitoring and comparison between buildings.

## 2.4 Energy Analysis

The second part of the cockpit presents a simple but clear user-friendly energy data analysis by using the cleaned real time data to monitor energy while linking consumption with real time period events.

As shown in figure 5, the energy consumption data was compared between day and night (day is the working hour of the corresponding building); weekday and weekends. The facility budget can be keyed in by the facility manager to see how the energy consumption meets the budget line. The aim of this energy analysis part is to formulate a link between energy usage and the actual physical activities consuming that energy. This is because the campus buildings energy consumption is highly related to semester schedules and vacation time [14] so this kind of energy data analysis can be used to generate a rough image of a physical activity profile of the building in a specified time period. The energy profile for weekends during semester time, vacation time, and exam period time, can be identified as an occupancy independent part, so that the energy profile of the occupancy dependent part during working days can be illustrated while highlighting the levels of occupancy influence on the energy consumption.



Fig 5: Energy analysis interface.

## 2.5 Smart Tool

In the third stage, smart tools with novel methodologies are implemented to provide an intelligent profile for the building facility manager and the users.

Figure 6 shows the first smart tool: Energy Forecasting. The methodology can be easily applied to different buildings because it reduces the degree of variation by dividing the energy consumption data into classes [15]. These class numbers are then taken as inputs for the forecasting model using Artificial Neural Networks (ANN). The model development along with the ANN architecture are run in the cockpit background with the high accuracy of  $R^2$  of more than 0.94 when forecasting the energy consumption for the next twenty days.

In the cockpit, the Forecasting tool predicts the electrical energy consumption and the air-con thermal energy prediction consumption of a building for the next two weeks. With the development of a forecasting model based on machine learning techniques and historical energy consumption data only, a set of boundary conditions can be provided and targets for the building facility managers and owners within which the building's energy consumption should ideally fall (daily, weekly, monthly, and annual targets). In addition, the forecasting algorithm can also be clubbed with smart sensors and control systems and equip them for future scenarios. It can also be combined with other simulation models like EnergyPlus and can be used to derive other operational factors like occupancy etc. Meanwhile, as the forecasting tool learns from previous energy consumption usage patterns, a gradual increase in the forecasted energy consumption values over a period of time may also notify the facility managers on the maintenance aspects of the building.

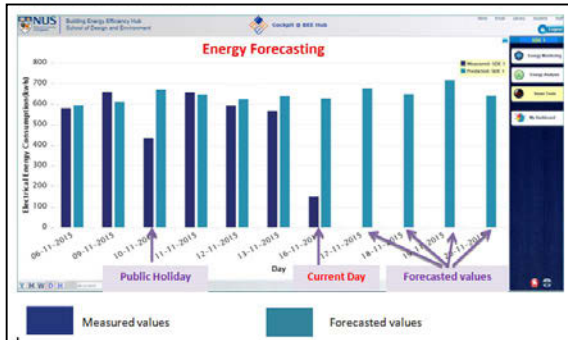

Fig 6: The forecasting tool updates itself every Saturday (12:00 am) and forecasts the energy consumption values for the next two weeks.

The second smart tool implemented in the cockpit is called Identification Tool. It is developed in order to learn the building energy consumption characteristics as well as get the knowledge of dynamic energy budget interrelationships by using the available data [16].

As shown in figure 7, the Identification tool identified three factors influencing the cooling load consumption. In the user interface, there are Four lines: the dark blue is the measured data; the light blue is the simulated cooling load based on function 1, Where function 1 is the daily variable based on the interrelationship between PLUG LOAD and HVAC LOAD (Basic occupancy in a building which will influence both), the red line is the simulated cooling load based on function 1 plus function 2, Where function 2 is the daily variable taking into account the difference between PLUG LOAD and HVAC LOAD (Occupancy variation which will influence the cooling load much more than the way it will influence the plug load), and finally the orange line, which is the simulated cooling load based on function 1 + function 2 + function 3, where function 3 is the daily variable, taking into account the daily outdoor air temperature variation.

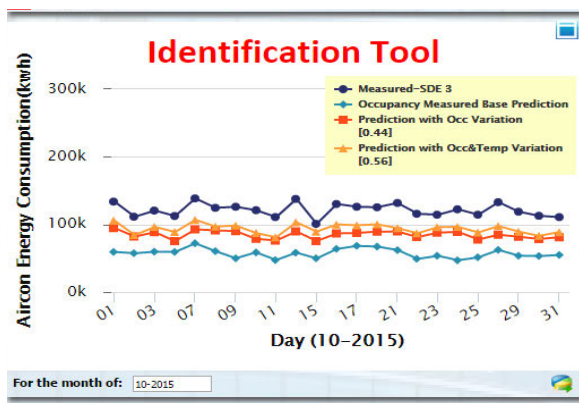

Fig 7: The Identification tool substitutes different parameters to identify energy consumption characteristics.

The identification tool's results are able to provide information to the facility management on how the three factors' results in the cooling load consumption vary daily. Meanwhile, the identification tool can be further used as an input into OCCUPANCY SCHEDULE of the ENERGY PLUS simulation software to achieve a higher simulation accuracy [14], which is the next phase of smart tool development.

The third smart tool is Clustering, which is the bottom level analysis of energy usage among a large group of buildings, in some cases done purely at the building type or at ground floor area, only identifying the one aspect of building characteristics. The cockpit clusters the campus buildings (60 at the first phase) into three groups based on the EUI as shown in figure 8. The clustering tool gives an overview of the energy consumption in a district campus level so that the next step zoom in analysis with the previous two smart tools can be applied.

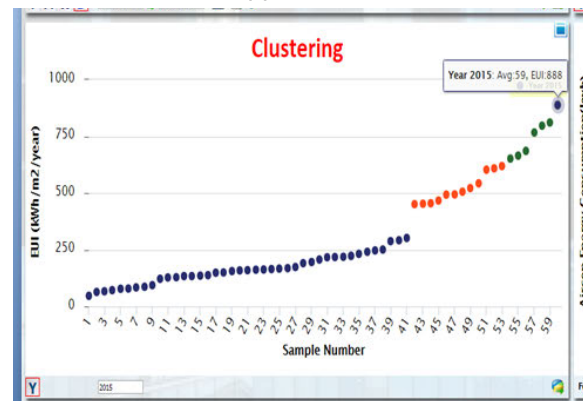

Fig 8: Clustering tool.

### 3 SUMMARY

An integrated and intelligent Energy cockpit not only includes the massive smart meter reading data, but also the huge story hidden behind the amount of data, such as building characteristics, occupancy activity pattern and the knowledge of dynamic energy budget interrelationships. It assists building energy management with data cleaning, data monitoring, data analysis and smart tool analysis with 4 horizontal dimensions (comparison up to four buildings) and 4 longitudinal dimensions (yearly, monthly, weekly and daily).

With the development of the Energy Cockpit prototype, a log in page with different levels of access is designed which meets the identified data security for data controlling. Hence, it provides different end users different levels of energy related figures with a more straightforward way. Discussions on the smart tool energy data management model development indicates, that the Cockpit strikes a new path when it comes to energy simulation and prediction on a research level.

In the end, in most organizations, facility managers are designated as main users of the Cockpit. However, some managers might not be able to work in a complicated web software interface. This Energy Cockpit, with its simple and clear user interface, provides a quick but comprehensive, accurate and whole energy consumption picture to the user.

#### 4 ACKNOWLEDGMENTS

The project is funded by National University of Singapore under CiBEST (BEE Hub).

#### 5 REFERENCES

1. Molle D. and Party P.M., RT 2012 et RT existant: Reglementation thermique et efficacite energetique – Construction et renovation. Editions Eyrolles, 2013
2. Waqas A, Ud Din Z. Phase change material (PCM) storage for free cooling of buildings—a review. *Renew Sustain Energy Rev* 2013;18: 607–25
3. Costello, G. J., Lohan, J. and Donnellan, B., 2010, Mobilising IS to support the diffusion of Energy Management Practices outside of Ireland's LIEN (Large Industry Energy Network), Proceeding of The 15th Annual Conference of the Association Information et Management (AIM 2010), IDDS, May 2010, La Rochelle, France.
4. The UK Carbon Trust - Industrial Energy Efficiency Accelerator (IEEA) Programme, 2014, <http://www.carbontrust.com/client>
5. IEA and IIP 2012; IEA (International Energy Agency) and IIP (Institute for Industrial Productivity). 2012. Energy Management Programmes for Industry: Gaining through saving. Paris, France: IEA Publications.
6. Duarte, C., Acker, B., Grosshans, R., Manic, M., Van Den Wymelenberg, K., and C. Rieger. 2011. Prioritizing and Visualizing Energy Management and Control System Data to Provide Actionable Information for Building Operators. Western Energy Policy Research Conference, Boise, ID, U.S.: August 25–26
7. Shaikh PH, Nor NBM, Nallagownden P, Elamvazuthi I, Ibrahim T. A review on optimized control systems for building energy and comfort management of smart sustainable buildings. *Renew Sustain Energy Rev* 2014;34:409–29
8. J. Yang, M. Santamouris, S.E. Lee, Review of occupancy sensing systems and occupancy modelling methodologies for the application in institutional buildings, *Energy and Buildings* (2015), <http://dx.doi.org/10.1016/j.enbuild.2015.12.019>
9. Lonescu C, Baracu T, Vlad G, Necula H, Badea A. The historical evolution of the energy efficient buildings. *Renew Sustain Energy Rev* 2015;49:243–53.
10. Zhou K, Yang S. A framework of service-oriented operation model of China's power system. *Renew Sustain Energy Rev* 2015;50:719–25.
11. Momoh JA. Smart grid design for efficient and flexible power networks operation and control. In: Proceedings of the power systems conference and exposition, 2009 PSCE'09 IEEE/PES. IEEE; 2009. p. 1–8.
12. Amin M. Challenges in reliability, security, efficiency, and resilience of energy infrastructure: Toward smart self-healing electric power grid. In: Proceedings of the power and energy society general meeting-conversion and delivery of electrical energy in the 21st century, 2008 IEEE. IEEE; 2008. p. 1-5
13. Zhou K, Yang S, Shen C, Ding S, Sun C. Energy conservation and emission reduction of China's electric power industry. *Renew Sustain Energy Rev* 2015;45:10–9.
14. Yang J., Santamouris M., Lee S., Deb C., Energy performance model development and occupancy number identification of institutional buildings, *Energy Buildings* (2015), <http://dx.doi.org/10.1016/j.enbuild.2015.12.018>
15. Deb C., LEE S.E., Yang J., M. Santamouris, Forecasting diurnal cooling energy load for institutional buildings using Artificial Neural Networks, *Energy and Buildings*(2015), <http://dx.doi.org/10.1016/j.enbuild.2015.12.050>
16. Yang J., M. Santamouris, L.S. Eang, C. Deb, Model Development and Comparison for the Evaluation of the Energy Performance of Three Tertiary Institutional Buildings in Singapore, *Procedia Eng.* 121 (2015) 1133–1143, <http://dx.doi.org/10.1016/j.proeng.2015.09.119>.





## Expanding Boundaries: Systems Thinking for the Built Environment

### CAMPUS SUSTAINABILITY RETROFITS: A MULTI-CRITERIA SITE SELECTION MODEL FOR LOW IMPACT DEVELOPMENT (LID)

A. Kamal<sup>1</sup>

<sup>1</sup> The University of Texas at San Antonio, 501 W. Cesar E. Chavez Blvd., San Antonio,  
Texas, USA

e-mail: [azza.kamal@utsa.edu](mailto:azza.kamal@utsa.edu)

#### Abstract

The Edwards Aquifer ecosystem is the only source of drinking water for millions of people in the US Central Texas Region. Approximately 15% of the Stormwater Pollution Prevention Engineering Structures, known as Best Management Practices (BMP), are not functioning sufficiently to prevent non-point source pollution from stormwater infiltration in these highly urbanized areas (GEAA, 2010 [3]). Because our University's main campus is located in the Edwards Aquifer Recharge Zone (EARZ), constructing new facilities or site enhancements on this campus is critical for this sole source of water supply. Funded by two regional agencies, this paper proposes systematic site selection tools using Geographic Information systems (GIS) to develop a geospatial analysis model for assessing the suitability of on-campus structured BMPs for improvement using Low Impact Development (LID) techniques. LID includes bioswale, rain garden, water harvesting, and green roofs as well as sustainable place-making edifices, which were proposed in the redesign phase. Site selection method encompassed: (i) identifying key issues pertaining to LID projects; (ii) analysing secondary data and site audits; (iii) create a GIS site capability model; (iv) analyse site suitability using a geospatial model. Programming and design priorities for a sustainable urbanism and ecological landscape were conducted. Design proposals were developed by an interdisciplinary team of architecture and civil engineering students. The toolkit developed in this paper will be adopted by the funding agencies to educate the general public and community groups on the benefits of adopting LID practices, and will also inform the state agency governing the EARZ regulations.

#### Keywords:

Low Impact Development; Stormwater Runoff; GIS; Multi-criteria Assessment; Sustainable Campus

## 1 INTRODUCTION

### 1.1 Edwards Aquifer Ecosystem

In the US Central Texas Region, the Edwards Aquifer (EA) ecosystem is the only source of drinking water for millions of Texans in different municipal, industrial, and agricultural uses, and at the same time sustains rare and endangered species. Human activities in that region, particularly in urbanized areas could, however face a degrading water quality, and therefore, different agencies have developed the EA rules and guidelines for development activities near the aquifer in order to protect it (Barret, 2005 [1]). One of the eight counties governed by these rules is

Bexar County, Texas. The County has slightly over 3,000 engineered stormwater filtration structures located on the Recharge Zone, a sensitive region of the aquifer that feed the entire reservoir (TCEQ, 2015 [2]). Approximately 15% of these structures are not functioning sufficiently to achieve the desired result of preventing pollution from infiltration in the highly urbanized sites (GEAA, 2010 [3]). While some of these inefficient structures are found in residential areas designated for maintenance by neighbourhood and home owner associations' residents, others are located in mixed-use and institutional areas. Our University's main campus and its surrounding neighbourhoods are among these urbanized

areas that are also located on the Edwards Aquifer Recharge Zone (EARZ) (See Figure 1). Developments for the campus expansion plans are crucial for the groundwater protection, and therefore, all plans must be approved by the TCEQ prior to any construction activities due to its potential contribution to water contamination. Like most of the engineered stormwater structures throughout Bexar County, campus Best Management Practices (BMPs) structures require regular maintenance and inspection in order to enhance their performance in water treatment and reducing runoff volume.

This paper is part of a broader study to select one of the dysfunctional engineered BMP structures, known as sand filter. Five sand filters are located in the University of Texas at San Antonio's (UTSA) main campus (see Figure 2). Sand filters are stormwater treatment structures that are constructed using engineered concrete systems that lack ecological response, aesthetics, and public open spaces. The broad funded study proposes a redesign of two structures that this paper identifies using the site selection tools. The paper represents a discourse of ecological landscape, urbanization, and stormwater management, and geospatial technology.

### 1.2 Impact Development and project goals

The United States Environmental Protection Agency (USEPA) divides water pollution sources into two categories: point and nonpoint. Point sources are those causing pollution at specific points or sites that discharge pollution (i.e. pipe, ditch, ship or factory smokestack). Nonpoint sources are surfaces that accumulate different types of chemical pollutants. According to Gaffield et al. (2003 [4]), when these chemicals are transmitted to groundwater during rain events it can cause different types of chronic and acute illnesses to people who drink the water. Pollution from these sources increases with urbanization and urban sprawl due to the increase of the amount of land covered with impervious surfaces such as roofs, roads, and parking lots (USEPA, 2015 [5]). In order to mitigate the impact of urbanization on groundwater contamination, site design techniques using Green infrastructure (GI) and Low Impact Development (LID) practices are proposed. The approach for integrating LID and GI in stormwater management intertwines ecological landscape and site design techniques. They are commonly used to reduce urban runoff and pollutants loading through on-site filtration of pollutants accumulated on nonpoint sources of contaminations such as parking lots. LID techniques perform through capturing water on site, filtering it through vegetation, and then penetrating it into the soil layers, where it can recharge groundwater reservoirs such as the Edwards Aquifer in Texas.

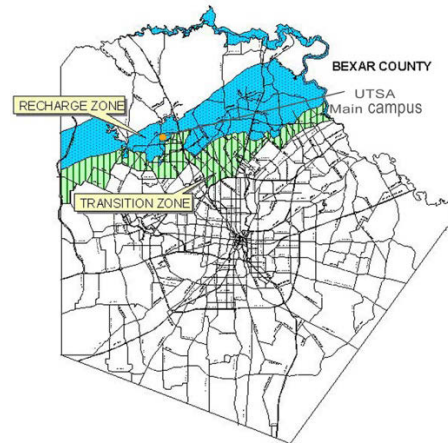

Fig. 1: Edward Aquifer region including Bexar County and the UTSA Campus.



Fig. 2: One of the Five UTSA Campus BMPs.

### 1.3 Ecology and Campus Sustainability

Ecology is known to be used to portray the mutual relationship between humans and their various environments (i.e. socio-cultural, political, and economic). Ecologies are depicted by multi-complex and insurgent layers that collectively inform the design of our urbanizing landscapes. These landscapes, in turn, continue to shape the ecologies that define us. Waldheim (2006 [6]) has observed that landscape is a synthetic phenomenon that has a lot to offer more than just a two-dimensional surface; and that it is "more than just the lens of representation; it is a medium of construction [and interaction]". If dealing with sites and their context is not limited to the physical components of the ground plane, and extends to embrace socio-cultural, political, and economic dynamics of landscape, new infrastructure typologies will emerge. As such, landscape in contemporary urbanism is defined through a multilayered process that requires a multifocal perspective of an intertwined culture and nature.

Policy makers endeavour to utilize innovative resources and programs to integrate landscape and ecological urbanism throughout North American universities campuses to enhance environmental performance (Mascarelli 2009 [7]). The growing recognition of financial and environmental benefits of adopting water conservation policies appeal to those administrators (Jackson-Smith et al. 2009 [8]).



Given that traditional landscape strategies are no longer practical or sustainable, campus sustainability endeavours raise student awareness of sustainability while maintaining school credits, as well as advance the leadership role of the university while benefiting society (Creighton 1999; Leal Filho 2009 [9] [10]). In Canada, the increase of cost and social demand for environmental stewardship make this challenge a recurring issue on the university agendas (Brandes and Ferguson 2004 [11]). In a move to institutionalize a campus-tailored program, in 2006, the Higher Education Associations Sustainability Consortium (HEASC) conceived a plan to improve campus sustainability. The plan, known as Sustainability Tracking, Assessment & Rating System (STARS), aims to increase awareness and knowledge of sustainability in higher education through establishing benchmark comparisons provided – via self-reporting and collaborative efforts – by all participating departments and offices. STARS guidelines cover various aspects of sustainability including health, social, economic, and ecological issues; it extends to all functions of a campus (i.e. curriculum, facilities, operations, and community engagement) (HEASC, 2006 [12]). STARS premise encompasses both long-term sustainability goals for already high-achieving institutions, and entry points of recognition for institutions that are taking first steps toward sustainability. Like most campuses wishing to apply STARS, UTSA LID design proposals encompass a number of possible credits that could be tracked, measured, and reported to HEASC.

## 2 DATA AND METHODS

Site selection model is a process for identifying one of the five existing water treatment sand filters in the UTSA main campus. Selected site is identified as a candidate site that is suitable for implementation of one – or more – type of Low Impact Development (LID) practices. Current sites assessed for this selection process are engineered stormwater infiltration BMPs that could benefit from a redevelopment using LID and could contribute to an improvement of campus life. The process was conducted by creating a geospatial site selection model that was developed using Geographic Information System (GIS). A review of LID-scholarly literature was used to develop two research parameters: (i) site characteristics, and (ii) pollutants loading from the areas around each engineered BMPs. Secondary data obtained from different sources (i.e. campus facilities planning office, and site audit), were compiled and used to create a univariate analysis for different attributes. A multivariate model using two-step analyses (capability, and suitability) was then created using the univariate analysis

according to the weight of each attribute. Weights were assigned to the attributes using feedback solicited from funding agencies and partners.

### 2.1 Key Issues Pertaining to LID Design

To embark on identifying the attributes for the site selection model, LID design goals were conferred using a method similar to Austin's working group task committee (City of Austin, 2015 [13]). In consultation with the funding agencies, and incorporating their vision of LID projects, we identified the following goals that are centred on the site characteristics and design strategies:

- Maximum exposure to raise awareness
- Re-naturalizing spaces to enhance liveability
- Ease of access
- Feasibility of plugging in sustainable edifices to enhance wayfinding
- Integrate xeriscaping practices
- Designs that improve and regulate efficient maintenance schedule

Building on the studies by (LaGro, 2001; Henderson et al., 2007; and Oiamo et al., 2015 [14] [15] [16]), the following attributes were used to measure the two research parameters: (i) land use, density, sensory, circulation, and high-traffic areas for measuring site characteristics. (ii) Street network, vehicle density, and distances associated with pollutants loading including nitrogen monoxide (NO), nitrogen dioxide (NO<sub>2</sub>), volatile organic compounds (VOC), and particulate matter (PM). A univariate GIS map for each attribute was created using the appropriate metrics listed in the literature (see Figure 3). Additional maps were added using on-site observation and documentation, known as site audit.

### 2.2 Site Audit using Systematic Observations

Audit forms are largely used in direct observation and assessment of public spaces and streets. System for Observing Play and Recreation in Communities (SOPARC) protocol (McKenzie, et al. 2006, and Whiting, J. W, et. al., 2012 [17] [18]), was utilized in active living research to document activity types and magnitudes. For this paper, audit form was used to document four site characteristics: (i) site visibility; (ii) access to site; (iii) activity areas by location and type; and (iv) primary nodes, and high traffic areas. Using the four types of activities categories by Gehl (2011 [19]), activities were classified based on type (walking, standing, sitting, and sporting), and time (morning and afternoon). The cumulative count of persons by each type and time of activity was estimated, and digitized using GIS point layer. A final GIS map was created for each activity. Accessibility by location and means (vehicle, pedestrian, bikes, and buses) as well as site visibility and nodes were observed, documented, digitized, and analysed using similar methods.

### 2.3 Geospatial Model for Site Selection

GIS provides flexibility, accuracy, and efficiency as a platform for its aptitude in visual and quantitative analysis (Collins et al., 2001; Malczewski, 2004; and Saleh and Sadoun, 2006 [20] [21] [22]). It is capable of linking location data with multiple attributes that are quantitatively coded. Its ability to perform spatial analyses on large amounts of data, makes it an effective visual and analytical tool for site suitability and geodesign approaches (McElvaney, 2012 [23]). Using GIS, a multivariate analysis model, comprised of two steps (capability, and suitability) of the five existing BMP sites on the university campus was conducted. The model follows the Massner (2012 [24]) geodesign approach, and was applied on the existing five BMP sites to eliminate those BMP structures that do not support the project goals.

### 2.4 Sites Capability Model

The first step of the geospatial analysis, a capability model, incorporated the univariate analysis to assess BMP sites potential to support design and site requirements for each typology (rain garden, swale, and bioretention basin). The following attributes were identified using six case studies of policy reports that discussed LID design and site requirements:

- Slope, including site with a maximum slope of 15%.
- Floodplain, including distance from the projected 100-year floodplain.
- Maximum exposure of site, including visibility.

### 2.5 Sites Suitability Model

The suitability model also integrated various variables, each represented through a series of univariate GIS maps (see Figure 4). The analysis encompassed the following parameters and attributes:

- Circulation: pedestrians, and buses
- High-traffic areas: main passages
- Activity areas: walking, sitting, standing and sporting
- Proximity to primary zones, academic buildings, and main passage
- Pollutants loading: including NO, NO<sub>2</sub>, VOC, and PM.

The two-step model compares the five campus BMP sites according to the attributes' metrics used in the scholarly literature, and assigns a ranking system based on a scale of 1-5 (worst to best) to each site. A cumulative score was calculated for each site.

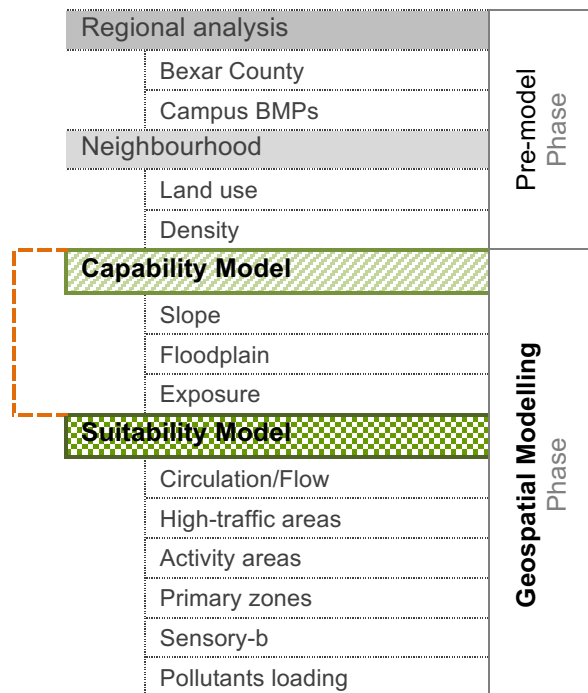

Fig. 3: Site Selection Process.

## 3 RESULTS AND DISCUSSION

The Geospatial site selection Model developed in this study was supported by scholarly literature as well as best practices of LID design criteria. The model aims to improve the dysfunctional stormwater treatment BMPs in the main campus of the University of Texas at San Antonio and, at the same time, to increase campus' STARS sustainability score. The five BMP sites examined in this study were analysed using quantitative and spatial analyses of secondary data and site audits. The five BMP sites were compared using reliable metrics associated with two parameters: site characteristics and pollutants loading. Out of the five sites, structures C & D met most of the capability and suitability criteria, and therefore were advanced to programming and development using LID design techniques.

C and D sites and their adjacent open spaces were redesigned by three multidisciplinary teams of senior and graduate students in architecture department as well as civil and environmental engineering department. Design concepts, program, and a GIS hydrology model for each water treatment site was developed, assessed, and fine-tuned. Proposed designs adopted the ecological landscape using xeriscaping for water conservation, in addition to incorporating local and affordable materials; and integrating a multi-treatment LID structures (rain gardens, bio swale) and water harvesting system.

#### 4 CONCLUSIONS

This paper presents a case study of water treatment design using Low Impact Development (LID) design techniques. The case study also explores the use of geospatial analysis model using GIS as well as site audit in site selection for mitigating water pollution and reduced runoff volume. LID design tools were strategized to replace existing engineered, and dysfunctional, BMP water treatment sites located in the UTSA campus. The improvement of two structures (C and D) will also promote sustainability through increasing the existing STARS score, and raise awareness through the exposure of the –yet to be-LID structures. The broader research that is inclusive of this paper will integrate the site selection model as a prototype for further implementation across the neighbourhoods and home owner association located on the Edwards Aquifer Recharge Zone. Criteria for the project goals and attributes in the two-step model (capability and suitability) could be replicated in other university campuses, neighbourhoods, and mixed-use areas.

The results of this paper raise awareness of the future professionals and ecologists who will be engaged in designing efficient stormwater pollution prevention structures, and mitigating stormwater runoff. It helps policy makers who are developing data-driven selection tools for allocating the resources for retrofitting engineered dysfunctional stormwater structures and sites through LID design techniques.

It also serves as a learning tool for future multidisciplinary courses on sustainability and



Fig. 4: Attribute used in the Univariate Analysis and One of the Two Proposed Designs.

#### 6 REFERENCES

1. Barret, M. E., *Complying with the Edwards Aquifer Rules Technical Guidance on Best Management Practices*, 2005, Texas Commission on Environmental Quality: Austin, Texas.
2. Texas Commission on environmental Quality (TCEQ), *Central Registry Query Regulated Entity*, 2015. Accessed 1/5/2015  
<http://www15.tceq.texas.gov/crpub/index.cfm?fuseaction=regent.RNSearch>

water conservation that university campuses could implement to raise awareness of the benefits of using native and drought-tolerant plants, conserving water, and enhances water quality through infiltration. Upon implementation of the proposed designs (see Figure 4), the site's visual quality and aesthetics will be improved, and the campus STARS score will be increased. Other benefits include the ease of maintenance, re-use of harvested water for irrigation, and the creation of spaces for outdoor social and educational activities around LID sites. The paper also informs future research and practices on the importance of integrating scientific metrics and geospatial models as data-driven tools that would inform design decisions. This paper highlights the significance of multidisciplinary collaboration in the study of urban sustainability, ecological landscape, and LID practices. Funding agencies of this study will adopt the site selection model in their pursuit to facilitate LID strategies and an incentive program across hundreds of communities, neighbourhood associations, and businesses in Bexar County, Texas.

#### 5 ACKNOWLEDGEMENTS

The author would like to thank the research sponsors: Edwards Aquifer Authority (EAA), San Antonio River Authority (SARA), and Greater Edwards Aquifer Alliance (GEAA). The author would also like to thank her research team: Fernando Morales, Jingqi Li, Dawne Butler, and Laura Bustillos.

3. Greater Edwards Aquifer Alliance (GEAA), *Permanent Stormwater Pollution Prevention Systems within the Edwards Aquifer Recharge Zone in Bexar County, Texas*, 2010, GEAA: San Antonio, Texas.
4. Gaffield, S. J., Robert L. G., Lynn, A. R., and Richard, J. J., *Public Health Effects of Inadequately Managed Stormwater Runoff*, *American Journal of Public Health*, 2003. 93(9): p. 1527-1533.

5. US Environmental Protection Agency (EPA), What is Nonpoint Source?, 2015. Accessed on 12/12/2015 <http://www.epa.gov/polluted-runoff-nonpoint-source-pollution/what-nonpoint-source>
6. Waldheim, C., *The Landscape Urbanism Reader*, 2006. New York, NY: Princeton Architectural Press
7. Mascarelli, A. L., How Green is your Capus?, *Nature*, 2009. Accessed 12/12/2015 <http://www.bioedonline.org/news/nature-news/how-green-your-campus/>
8. Jackson-Smith, D.B., M. Halling, E. de la Hoz, J.P. McEvoy, and J.S. Horsburgh, Measuring Conservation Program Best Management Practice Implementation and Maintenance at the Watershed Scale, *Journal of Soil and Water Conservation*, 2009. 65(6), p. 413-423.
9. Creighton, S. H. *Greening the Ivory Tower: Improving the Environmental Track Record of Universities, Colleges, and Other Institutions*, 1998, Cambridge, MA: MIT Press
10. Leal Filho, W., *Sustainability at Universities: Opportunities, Challenges and Trends*, 2009. New York, NY: Peter Lang Publishing, Inc.
11. Brandes, O., and K. Ferguson, *The Future in Every Drop: The Benefits, Barriers and Practice of Urban Water Demand Management in Canada*, 2004. Victoria: POLIS Project on Ecological Governance, University of Victoria, May.
12. Higher Education Associations Sustainability Consortium (HEASC). *The Sustainability Tracking, Assessment & Rating System*, 2006, accessed on 12/12/2015 <http://heasc.aashe.org/>
13. City of Austin: Watershed Protection Department, *Green Infrastructure Working Group summary*, 2015. Accessed on 1/6/2015 <file:///C:/Users/mom508/AppData/Local/Microsoft/Windows/INetCache/IE/LK6RIKIT/GIWG-Stakeholder-Feedback-and-Recommendations.pdf>
14. LaGro, J., *Site analysis: Linking Program and Concept in Land Planning and Design*, 2001. New York, NY: Wiley.
15. Henderson, S. B., Beckerman, B., Jerrett, M., & Brauer, M., Application of land use regression to estimate long-term concentrations of traffic-related nitrogen oxides and fine particulate matter. *Environmental Science & Technology*, 2007. 41, pp. 2422–2428.
16. Oiamo, T. H., Johnson, M., Tang, K., and Luqinaah, I. N., Assessing traffic and industrial contributions to ambient nitrogen dioxide and volatile organic compounds in a low pollution urban environment, *Science of the Total Environment*, 2015. October, p. 1;529:149-57
17. McKenzie, T., Cohen, D.A., Sehgal, A., Williamson, S. & Golinelli, D., System for Observing Play and Recreation in Communities (SOPARC): Reliability and Feasibility Measures, *Journal of Physical Activity and Health*, 2006. 3, p. S208-S222.
18. Whiting, J. W., Larson, L. R., and Green, G. T., Monitoring Visitation in Georgia State Parks Using the System for Observing Play and Recreation in Communities (SOPARC). *Journal of Park and Recreation Administration*, 2012. 30 (4), pp. 21-37.
19. Gehl, J., *Life Between Buildings: Using Public Space*, 2011. Washington, DC: Island Press.
20. Collins, M.G., Steiner, F.R., Rushman, M.J., *Land Use Suitability Analysis in the United States: Historical Development and Promising Technological Achievements*. *Environ. Manage.* 2001. 28 (5), 611–621.
21. Malczewuski, J., *GIS based Land Use Suitability Analysis: A Critical Overview*. *Progress in Planning*, 2004. 62, pp. 3–65.
22. Saleh, B. and Sadoun, B., Design and Implementation of A GIS System for Planning. *International Journal on Digital Libraries*, 2006. 6(2), 210–218. *symposium on LCA and construction*. 2012: Nantes, France. p. 65-72.
23. McElvaney, S., *Geodesign: Case Studies in regional and Urban Planning*, 2012. ESRI: Redlands, California.
24. Messner, M., *Red Fields into Green Fields*. In S. McElvaney, *Geodesign: Case Studies in Regional and Urban Planning*, 2012. Redlands, CA: ESRI, pp.102-116.

Zurich, June 15-17 2016

Sustainable Built Environment (SBE) Regional Conference

## Expanding Boundaries: Systems Thinking for the Built Environment



### LCA ENHANCEMENT PERSPECTIVES TO FACILITATE SCALING UP FROM BUILDING TO TERRITORY

G. Sibiude<sup>1,2\*</sup>, A. Mailhac<sup>1,2</sup>, G. Herfray<sup>1</sup>, N. Schioppa<sup>1,2</sup>, A. Lebert<sup>1,2</sup>, G. Togo<sup>1</sup>,  
P. Villien<sup>1,3</sup>, B. Peuportier<sup>1,4</sup>, C. Vaele<sup>1,5</sup>

<sup>1</sup> Efficacy - R&D Institute Energy Efficiency for a Sustainable City, Champs-sur-Marne, France

<sup>2</sup> University Paris-East, Scientific and Technical Centre for Buildings (CSTB), Saint Martin d'Hères, France

<sup>3</sup> TH1 Villien – Architecture Agency, Lagny-sur-Marne, France

<sup>4</sup> Center for Energy efficiency of Systems MINES ParisTech, Paris, France

<sup>5</sup> TPF-I, Marseille, France

\* Corresponding author; e-mail: [galdric.sibiude@cstb.fr](mailto:galdric.sibiude@cstb.fr)

#### Abstract

Environmental performance considerations in the construction sector extend from buildings to neighbourhoods, cities and territory. This transition implies a Life Cycle Assessment (LCA) adaptation to efficiently treat such complex systems. Indeed, performing environmental performance evaluations has already been done over the past few years but the existing LCA tools have to be improved regarding their user-friendliness to allow everyday urban planning stakeholders to use them. Providing keys to help the practice is a main subject to spread the large scale LCA evaluation and ensure a better urban planning trending to sustainable solutions. This objective is also motivated by local, national and European policies, particularly within the context of Paris COP21.

The aim of this study is to explore enhancement perspectives to facilitate LCA scaling up from building to territory. This work is based on observations from case studies underlining operational issues due to the evaluation time consumption. The urban planning process is analysed to focus, at different stages, on operational responses that could be proposed considering objectives, stakeholders' needs and potential drivers. In particular, for early stage decision making, an approach introducing urban typo-morphologies has been adopted to facilitate the comparison of large scale evaluations and scenarios. Such typo-morphologies, representing elemental bricks at building or block scale to build neighbourhoods or larger, have been widely described in the past. However, this work concentrates on the applicability of the approach to integrate this sort of description for environmental evaluation based on a multi-component (buildings, energy, water, public spaces, transportation) description of the systems. Particularly, a focus has to be given to scaling up mechanism. Expert systems sets on heuristic rules could help exploiting a typo-morphologies database. This solution should ease the practice of urban environmental assessments.

#### Keywords:

Urban morphologies, Systemic approach, LCA

## 1 INTRODUCTION

The world's population is continuously increasing and expected to reach 9.3 billion people by 2050 [1]. In addition to the fact that cities accommodated more than 50% of the world's population in 2009 [2], most of the increase is likely to be absorbed by urban areas. This implies expanding energy, water and resources demands, increasing waste production and greenhouse gas emission. In this context, the evaluation and characterization of urban areas become of first interest to ensure a sustainable development.

Environmental performance considerations in the construction sector extend from buildings to neighbourhoods, cities and territory. This transition implies a Life Cycle Assessment (LCA) adaptation to efficiently treat such complex systems. Indeed, performing environmental performance evaluations has already been done over the past few years but the existing LCA tools have to be improved regarding their user-friendliness to allow everyday urban planning stakeholders to use them. Providing keys to help the practice is a main subject to spread the large scale LCA evaluation and ensure a better urban planning trending to sustainable solutions. This objective is also motivated by local, national and European policies, particularly within the context of Paris COP21.

In this context, Efficacy [1] (research & development institute specializing in the field of urban energy efficiency) aims to equip decision-makers, communities and all other urban stakeholders with operational tools to evaluate the environmental performance of districts and cities. This is not only a matter of methodological development but also to find convenient solutions to adapt the description process, the project data collection and the granularity of environmental data to user needs. Such an adaptation shall lead to an appropriate practice considering user's constraints and furnish intelligible results.

To ease the practice of LCA from the well-known building scale to upper scale, the creation of knowledge on urban typo-morphologies will be highlighted as a possible answer. An urban typo-morphology is a qualitative and quantitative description of a representative sized part of a city. It can widely describe this system including all the different components or focus on some interesting elements considering the purpose. Many works have already been performed on building [4] or urban typo-morphologies. These works are often focused on a particular thematic, such as thermal comfort [5] or urban heat islands [6], solar access [7] and energy [4], [8]. Few of them are related to environmental performance subjects [9] or giving a multi-thematic vision [10], [11] and even fewer are proposed to be used for an environmental aLCA evaluation [12], [13].

We propose to expose reflections and perspectives to build an urban typo-morphologies library which would be a data support for urban LCA tools. Urban LCA tools are understood as software to quantify environmental performance taking into account the different components (building, public space [parks, sidewalks, street lighting], transportation infrastructure, energy and water utilities and associated mobility, energy, water and waste flows). The components need a simulation or simplified calculation system to be evaluated. The tool's flexibility shall allow the input of variable data granularity.

This paper will present interests and drawbacks of getting such a library by positioning our objectives and the problem to be solved, the in-test methodology and discussions about it. Even if this work is at its beginning, the discussions will give some foreseen enhancement perspectives.

## 2 CONTEXT, GOALS AND UNDERSTANDINGS

This section gives insight into the context motivating this work, the goals aimed by the future results. It should finally provide understandings of the interest of having a middle scale granularity to describe cities and urban projects.

### 2.1 Modelling urban system - Limitations

Our approach to assess an urban system's environmental performance is based on systemic LCA in order to get a global overview without neglecting parts of the system or interactions between them. LCA is a solid scientific-based methodology allowing the identification of hot spots in an environmental performance. Its life cycle vision and multicriteria aspect make it a decision support tool which enables to avoid pollution shifts. However, urban systems are highly complex to both describe and understand. So, despite, the strong capabilities, the method remains time-consuming and difficult, particularly for complex systems [14] such as urban projects and cities. This is due to:

- System description (high input number and information collection)
- Choice of appropriated environmental data

In fact, the description of each components of a district can consist in listing all constitutive parts. For example, a building needs to be described considering all construction products and equipment, and also, the different flows (energy, water, waste, etc.).

One way to go through this difficulty is to capitalize and create knowledge, translated in environmental data, to describe buildings, urban blocks or districts at a convenient granularity. Then, the description of the system will be reduced to fewer inputs representing the system

(square floor area for each building typology, transport solution, energy systems, etc.) directly associated with this high-granularity data.

## 2.2 Objectives – An adaptation to user needs through a multi-scale database

As previously exposed, a possible way to overpass the presented limitations is to facilitate the description by adapting input data to the interesting question and the available system information.

In fact, conducting an urban project is a long and in constant evolution process in which the information to describe and the questions are changing.

As said previously, design district with high environmental performances is crucial. To achieve this, different studies point out that early decisions in the design process have the most influence. Despite this fact, current assessments of environmental or energy performances is mainly run quite lately in the project's design process.

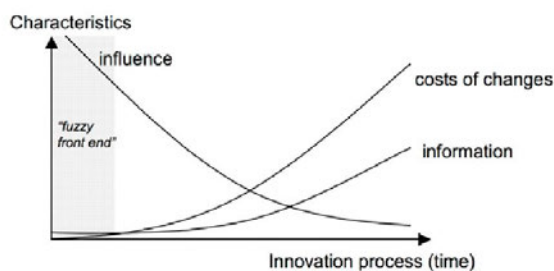

Fig. 1: Evolution of influence, costs of changes, and information during the innovation process (von Hippel [15], modified by Herstatt & Verworn [17]).

Then, it is of key interest to produce an environmental database at a different scale. In this way, the stakeholder can adapt the LCA granularity to his knowledge, question and available time. This database can be seen as a "Russian doll" system in which zoom in and out can be performed.

Potential applications of this library are multiple:

- Facilitate territorial diagnostic and community evaluation at larger scales without being too time consuming
- Give a first environmental performances estimation of specific urban projects in early stage through simplified LCA

We believed that it could also facilitate interactions between stakeholders and simplify the inputs.

## 3 METHODOLOGICAL PROPOSITIONS

Here is a proposition to construct the aimed database presented. This methodological process is currently being tested.

### 3.1 Global approach

The approach consists of defining types of urban morphologies classified by considering parameters that have to be linked to levers for decision-making (for example, footprint or constructive system depending on project, location, etc.). Those types have to offer, as much as possible, a systemic vision by taking into account not only building (as often done) but also public space (parks, sidewalks, streets lighting), transportation infrastructure, energy and water utilities and associated mobility, energy, water and waste flows.

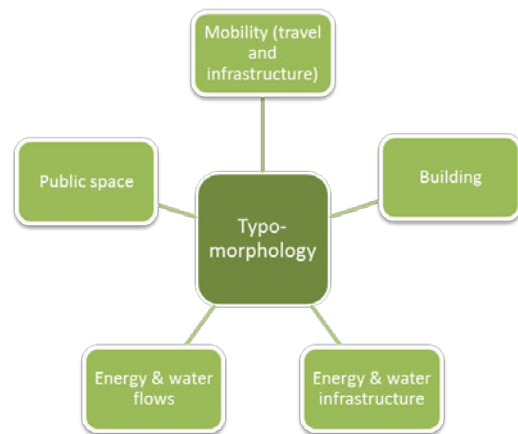

Fig. 2: Schematic representation of urban typomorphology components.

Fig. 2 gives an illustration of the different components to consider. However, this schematic view is simplified and the systemic approach implies interactions and links between each component. As an example, energy flows need building thermal evaluation to be quantified.

To build a dataset including all these different aspects, detailed modelling of each one (building, public space, etc.) must be performed [15]. It is only the statistical analyses of large samples that can make the approach consistent. Representativeness and relevance of the obtained data are directly connected to the robustness of the samples and input data to evaluate each element. To overcome this time-consuming process, extrapolations can also be done to obtain values when statistical analyses are not achievable in the short-term. These values could further be consolidated/updated when more robust ones are obtained.

### 3.2 Data construction

To lead to an urban typomorphologies library, several data, survey and information sources can be used:

- National survey
- Geographical Information System (GIS)
- Community and territory local survey and database
- Local stakeholders' knowledge and expertise

The use of upstream data and information accessible on a large territory would make the methodology contextualization easier. For this reason, the above list is given in order of preference. It is then of major interest to prioritize the exploitation of national data in the model of input data to be used to evaluate the urban typomorphology performance. In that way, it will make the applicability of the method much easier in every city.

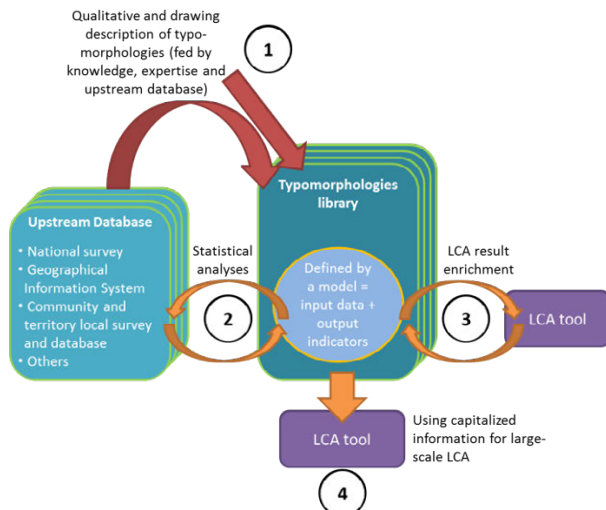

Fig. 3: Methodology scheme for urban typomorphologies library elaboration and application.

Fig. 3 exposes the methodology to obtain the urban typomorphologies library. The different steps are:

- (i) Defining the urban typomorphologies
- (ii) Create input data for each typomorphology which will be used in the next step
- (iii) Evaluate the typomorphology environmental performance
- (iv) Use typomorphology in LCA tool for large-scale (neighbourhood, city) evaluation

Step (i) can be completed by using statistical information from the different databases but also including knowledge and expertise from local stakeholders. In fact, people involved in territories often have much more information and a more operational view to describe urban typomorphologies. The objective will be to characterize qualitatively and quantitatively representative cells of the city. As an example, a 200x200 m cell could be determined as:

- Representative of the city centre;
- With 90000 m<sup>2</sup> of multiple-dwelling built in 1975;
- With 10400 m<sup>2</sup> of commercial area built in 1975;
- With a mid-size roadway and access to tramway

- And 5000 m<sup>2</sup> of public spaces (parks, sidewalks)

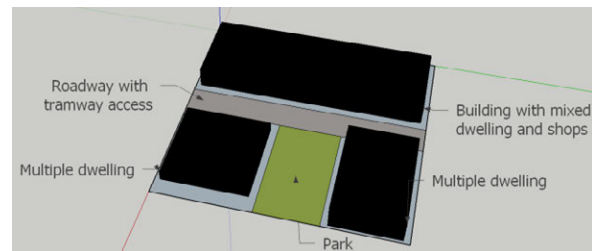

Fig. 4: Typo-morphology example in a 200x200m cell

Fig. 4 illustrates the previous description. This example is given as an illustration and could be less or more detailed, depending on the purpose. This description is closely linked to typologies for each component (building, public space, etc.). Examples for building typologies [18], [20] can be found to illustrate the purpose.

Step (ii) consists of collecting appropriate data to feed the simulation of the described system from Step (i). Then, Step (iii) is consecrated to the environmental performance evaluation throughout a LCA tool. It leads to a quantitative description for the considered typomorphology including all sub-components (flows and materials). This performance is then considered as data which can feed an urban LCA calculation in Step (iv). Step (iv) can be performed with the same tool as Step (iii) but fed with this constructed database (then, allowing a different input granularity).

Among the different descriptions collected in Step (i), some could lead to a similar environmental performance. Consequently, identifying sensitive parameters will be a crucial part to adapt the library. Also, within this set of parameters, it will be necessary to recognize those related to the system location or not. In fact, if a parameter is location-related, it would be essential to run Step (iii) considering it to get an urban data adjusted to the location that could further be used for urban calculations. The modification of the location can be done between cities/communities or within a city to differentiate the centre and the suburbs for example.

The application of the presented method leads to a mixed-methodology of reference-families [19] (consisting in defining representative types in a location; for example, considering the period of urbanization) and statistical methods to build urban typomorphology data.

### 3.3 Cell dimension

The cell dimension remains an unsolved intricate question at this point since this dimension adjustment is directly correlated to user needs, the system size and the aimed accuracy. For this reason, and as previously mentioned, an adapting scale system (similarly to "Russian



dolls”) could constitute the best answer. In this way, one can adjust the description to its needs. This adaptation is also necessary to fit with different contexts. In fact, from a city to another, the relevant size can differ. Commonly, the side dimension of the cell would be of a few ten or hundred meters depending on the distance between intersections (according to the country and city) and the expected representativeness. It is important to note that the methodology will remain the same whatever the cell dimension and that continuum between scales is necessary. This means that data at a higher scale (for example 500x500m if 250x250m is chosen in a first time [20]) can be obtained by aggregation of smaller ones.

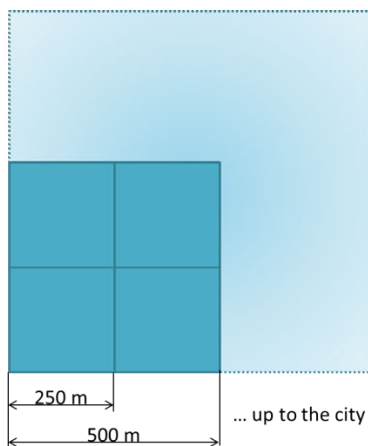

Fig. 4: Example of data granularity for houses.

Fig. 4 presents the aggregation concept to create higher scale data from smaller one. A key point will be to correctly consider interactions between the cells. In fact, some components can easily be aggregated by a simple additive principle when others are influenced by a near or more distant environment (in the meaning of context). For example, buildings can be approximated as additive and not much influence by surrounding cells (excepting some pooling of resources or modification [such as shading]) when mobility in a cell is highly influenced by its context (traffic or accessibility in a cell greatly influences its surroundings).

The interest in getting small cells is to increase the sensitivity and reach a more convenient scale to consider simplified evaluation of specific projects. In fact, the specific urban project's size (from a few hundreds of square meters to a few square kilometres) leads to the need of small cells to get the most representative as possible simplified results before switching to the most detailed simulation.

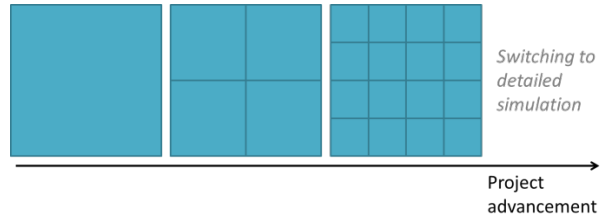

Fig. 5: Example of data granularity for houses.

Fig. 5 explains the need of reducing the cell dimension when typo-morphologies are used in specific project evaluations until the switch to detailed simulation. In early phases of the project, a large and quick assessment could be sufficient to get an order of magnitude of the likely-aimed performance. Then, the project evolution brings new information and description data which enable a thinner description making smaller cell dimension of interest.

### 3.4 Sensitive parameters

To define “types” (methodology Step 1), sensitive parameters have to be determined. For example, some key programming parameters could be listed:

- Building typology and morphology (volume and materials)
- Construction density (building, public space and mobility infrastructure)
- Constructive systems
- Mobility (network quality and accessibility)
- Energy performance

Many other parameters could be considered but this example set has been limited to ensure the applicability. In particular, the location should modulate the data as mentioned previously. It is necessary to focus in a first time on parameters:

- Of great influence on environmental performance
- Comfortably appreciable for stakeholders (designers, decision makers, etc.)
- Easily taken into LCA tools

All other parameters could further be implemented when knowledge and tools are constantly getting updated.

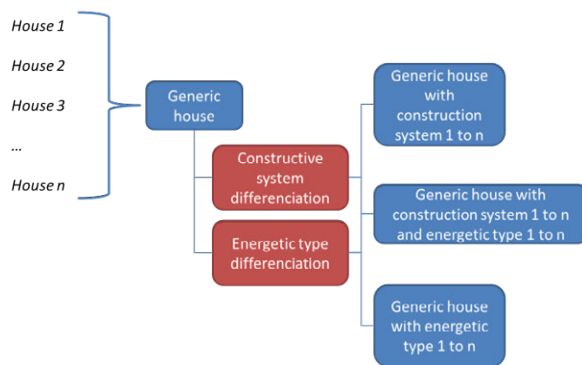

Fig. 6: Example of data granularity for houses.

Fig. 6 points out the room of manoeuvre existing to define types for the system components through the example for houses. The granularity choice has to be adapted to needs and considered according to its influence on the results.

To solve this question, sensitivity studies must be performed on the considered parameters. Since the number of parameters could be very high, it is necessary to define priorities depending on the aspects of interest for stakeholders and applicability in LCA tools in the short and medium term.

According to the analyses that will be made by the sensitivity studies, the types will be defined by splitting or merging

#### 4 DISCUSSION

The above propositions will lead to the definition of a contextualized typo-morphologies library. It will be a database to support LCA tools for territorial diagnostic and early-phase specific project evaluations. Beyond the contextualization aspect, the most convenient path to structure this library will be to aim a multi-scale system.

A first case study is being performed to validate the feasibility (some should be soon communicated). In particular, sensitive studies will give highlights about cell dimension and system's component data granularity questions. As presented, there is likely no best and unique answer since different relevant levels could exist according to user needs. For this reason, the case study is done in collaboration with a community to involve stakeholders in the methodology improvement and submit them alternatives. This process must lead to an operational solution responding to field considerations and helping the transfer to numerous current means objectives to a performance approach.

A key point mentioned in this paper is to take into account the interactions between cells. In fact, for some components, the performance within a typo-morphology can be greatly influenced by surrounding bricks. To evaluate the results' uncertainty due to this interaction when

considered or not, it may be necessary to compare the aggregation of two cells and one bigger cell equivalent to the re-constitute one.

A lot of hypotheses or statistical data will have to be considered to evaluate each typo-morphology. Ideally, the results should illustrate scattering due to these different hypotheses and statistical distribution. In that way, it would give precious information to make a decision with a risk assessment.

#### 5 CONCLUSION

This 1st version methodology describes the founding of the work being done and pursued objectives. The result should bring an innovative solution directly operational to run with LCA tools in order to facilitate territorial diagnostic and an early-phase specific project evaluation. Thanks to the flexibility to make it adaptable to the location and the scale of description, the library should readily be compatible with different purposes, questions and needs.

The different elements and recommendations exposed are still in experiment but based on bibliographical reviews to focus on the relevant conditions to link it with our needs in LCA tools.

Some discussed points may also greatly enhance its operability and consolidate its suitability for field stakeholders as a support for decision making.

We believe this approach to be of prime interest to help introduce environmental performance evaluation tools in the conception process. The solution will increase the user-friendliness of a still complex and time-consuming method and associated tools.

Further perspectives should finally consist in turning the approach to a global sustainability one. In fact, this paper only considers the environmental pillar of sustainability. The extension to economical and sociological matters may be the future step of this work.

#### 6 ACKNOWLEDGMENTS

This work is being performed in the frame of the research institute Efficacy. First examples and tests are done in collaboration with the Cergy-Pontoise community.

#### 7 REFERENCES

1. U.N. world urbanization prospects: the 2011 revision. Department of economic and social affairs, United Nations, New York (2012), p. 318.
2. United Nations Human Settlements Programme. *Planning sustainable cities: global report on human settlements 2009*. Earthscan, London; Sterling, VA (2009).

3. Efficacy. <http://www.efficacy.com/home>.
4. Salat S. *Energy loads and CO2 emissions of 96000 buildings in Paris: morphologies, typologies, energy systems and behavior*. BRI, 2009.
5. Ali-Toudert F., Mayer H. *Numerical study on the effects of aspect ratio and orientation of an urban street canyon on outdoor thermal comfort in hot and dry climate*. Building and Environment, 2006.
6. Bouyer J., Musy M., Huang Y., Athamena K. *Mitigating urban heat island effect by urban design: forms and materials*. Fifth Urban Research Symposium, 2009.
7. Arnfield A J. *Street design and urban canyon solar access*. Energy and Buildings, 1990.
8. Ratti C, Baker N, Streemers K. *Energy Consumption and Urban Texture*. Energy and Buildings, 2005.
9. Adolphe L. *A simplified model of urban morphology: application to an analysis of the environmental performance of cities*. Environment and Planning B: Planning and Design, 2001.
10. Bonhomme M., Masson V., Adolphe L. *GENIUS: A tool for classifying and modelling evolution of urban typologies – Part 1 Synchronic Modelling*. Environment and Planning B: Planning and Design, 2014.
11. Bonhomme M., Masson V., Adolphe L. *GENIUS: A tool for classifying and modelling evolution of urban typologies – Part 2 Diachronic Modelling*. Environment and Planning B: Planning and Design, 2014.
12. Nichols B.G., Kockelman K.M. *Life-cycle energy implications of different residential settings: recognizing buildings, travel, and public infrastructure*. Energy Policy, 2014.
13. Norman, J., H. Mac Lean, and C. Kennedy. 2006. *Comparing high and low residential density: Lifecycle analysis of energy use and greenhouse gas emissions*. Journal of Urban Planning and Development 132(1): 10–21, 2006.
14. Cluzel F., Yannou B., Leroy Y., Millet D. *Proposition for an adapted management process to evolve from an unsupervised Life Cycle Assessment of complex industrial systems towards an eco-designing organization*. Concurrent Engineering: Research and Applications, 2012.
15. Popovici E., Contribution to the life cycle assessment of settlements, PhD thesis, Ecole des Mines de Paris, 204 p, 2006
16. von Hippel E. *Wettbewerbsfactor Zeit. Moderne Industrie*; 1993; in The Fuzzy Front End of Innovation, working paper by Herstatt C. and Verworn, B., 2001.
17. Herstatt C, Verworn B. *The fuzzy front end of innovation*. Working Papers / Technologie- und Innovationsmanagement, Technische Universität Hamburg-Harburg, No. 4, 2001.
18. Steemers K., Baker N., Crowther D., Nikolopoulou M., Stankovic S., Kaplicky J., Leveté A., Pond A., Adolphe L., Schwenke J. *Towards Zero-Emission Urban Development*. in: Zervos, A. and Sala, M., Renewable Energy Development, EDIFIR, Florence, 1996.
19. APUR. *Consommations d'énergie et émissions de gaz à effet de serre liées au chauffage des résidences principales parisiennes*. 2007
20. Masson V., Marchadier C., Adolphe L., Aguejdad R., Avner P., Bonhomme M., Bretagne G., Briottet X., Bueno B., de Munck C., Doukari O., Hallegatte S., Hidalgo J., Houet T., Le Bras J., Lemonsu A., Long N., Moine M.-P., T. Morel, Nolorgues L., Pigeon G., Salagnac J.-L., Vigié V., Zibouche K. *Adapting cities to climate change: A systemic modelling approach*. Urban Climate, ICUC8, 2014.





## Expanding Boundaries: Systems Thinking for the Built Environment

### LCA APPLICABILITY AT DISTRICT SCALE DEMONSTRATED THROUGHOUT A CASE STUDY: SHORTCOMINGS AND PERSPECTIVES FOR FUTURE IMPROVEMENTS

A. Mailhac<sup>1,2</sup>, G. Herfray<sup>1</sup>, N. Schioppa<sup>1,2\*</sup>, N. Kotelnikova-Weiler<sup>1,3</sup>, A. Poulhes<sup>1,3</sup>,  
S. Mainguy<sup>1,4</sup>, J. Grimaud<sup>1,5</sup>, J. Serre<sup>1,6</sup>, G. Sibiude<sup>1,2</sup>, A. Lebert<sup>1,2</sup>, B. Peuportier<sup>1,7</sup>,  
C. Valean<sup>1,8</sup>

- <sup>1</sup> Efficacy - R&D Institute Energy Efficiency for a Sustainable City, Champs-sur-Marne, France  
<sup>2</sup> University Paris-East, Scientific and Technical Centre for Buildings (CSTB), Saint Martin d'Hères, France  
<sup>3</sup> Mobility, Urban planning, Transport Laboratory (LVMT), University Paris-East, Champs-sur-Marne, France  
<sup>4</sup> Arcadis, Villeurbanne, France  
<sup>5</sup> Veolia / 2EI - Eco Environnement Ingénierie, Paris, France  
<sup>6</sup> Veolia Research and Innovation, Paris, France  
<sup>7</sup> Center for Energy efficiency of Systems MINES ParisTech, Paris, France  
<sup>8</sup> TPF Ingénierie, Bourg-la-Reine, France  
 \* Corresponding author; e-mail: nicoleta.schioppa@cstb.fr

#### Abstract

To meet the current challenges of sustainable development, the environmental assessment of urban projects is essential to developing substantial arguments regarding their performances. To do so, the Life Cycle Assessment (LCA) starts to be applied to large systems such as neighbourhoods. The advantages of this methodology (e.g. evaluating pollution transfers, considering a wide range of local or global impacts, etc.) make it a good candidate for an efficient performance assessment. Nevertheless, districts are highly complex systems, their scope includes various sectors such as construction, transport, energy, water and waste management. Existing tools have to be adapted in order to simulate all these sectors in a systemic way. To achieve such an ambitious goal, the first step is to harmonize the analytic simulation of district components.

The aim of this work is to identify key elements that may improve the systemic simulation of districts and thus ensure a better assessment of their environmental performances. The work is based on the study of a four-hectare project located in the Paris region. Simulations of project's associated mobility, buildings and district energy consumptions and waste and water management have been combined to provide global environmental evaluation based on the LCA methodology. This study shows the relevance of adopting multi-domain simulations in order to evaluate relative contributions of the system's different components. However, to enhance the coherence of holistic evaluation, further work is needed to harmonize methodological choices such as allocation criteria and definition of functional units. Also this study underlines the need to use consistent and harmonized assumptions (e.g. for usage scenarios) and to work at different scales for network-based activities (e.g. mobility) in order to take global and local interactions into account. To overcome these challenges potential solutions are put forward and their feasibility and perspectives are presented in the context of urban planning projects.

#### Keywords:

Systemic approach; LCA; multi-domain evaluation; mobility; building; energy; waste and water management

## 1 INTRODUCTION

Environmental performances assessment of urban projects is essential to meet the current challenges of urban sustainable development.

In recent years, LCA has been applied to large and complex systems such as district [1]–[3], urban facilities [4], [5] and territory [6]. However, prevalent challenges remain for LCA application at district scale [3]. This work aims to identify key elements that may improve and ease the systemic simulation of districts and thus ensure a better assessment of their environmental performances.

Firstly, we will introduce our approach to urban system modelling and simulation. We will then present its application through a case study and finally discuss the limits and perspectives of district systemic simulation.

## 2 URBAN SYSTEM SIMULATION

### 2.1 District model

Districts are complex systems, to describe them we use a hybrid model (figure 1) based on district object-oriented description [7] and building contributors-oriented model [8].

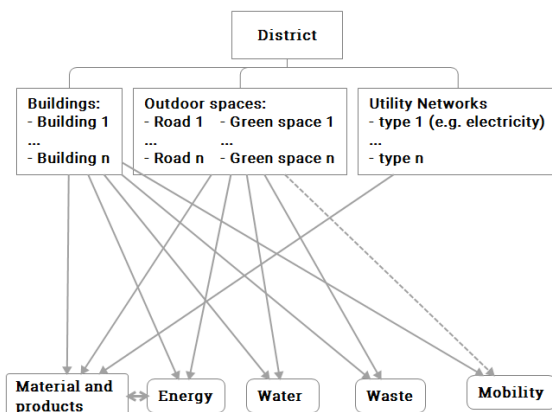

Fig. 1: District modelling.

We distinguish a) **3 types of objects:**

- **Buildings:** all use types and morphologies of buildings can be considered here
- **Outdoor spaces** of any kind: public space, green space, road network
- **Utility networks:** network for water furniture, sewage, electricity, gas, telecom and urban heating network

And b) **5 types of contributors:**

- **Material and Products** necessary for construction, rehabilitation and disposal of buildings, outdoor spaces and utility networks
- **Energy** necessary in the use phase of buildings (e.g. heating) and outdoor spaces (e.g. street lighting)

- **Water** (tap water, rainwater and wastewater) flow in the use phase of buildings and outdoor spaces
- **Waste** generated in the use phase of buildings and outdoor spaces
- **Mobility** of people living or working in the buildings

This model is structured to emphasize the interactions between district components: between buildings (e.g. shadowing), between buildings and mobility (e.g. influence of urban density on public transportation viability), between buildings and waste production...

In the remaining part of this section, we will present how each contributor is modelled and assessed.

### 2.2 Material and energy simulation

In buildings, energy consumptions related to heating, air conditioning, ventilation and lighting are closely linked to the buildings' material energy performances and buildings form. Thus, we jointly evaluate material and energy contributors through buildings dynamic energy simulation combined with LCA (see figure 2).

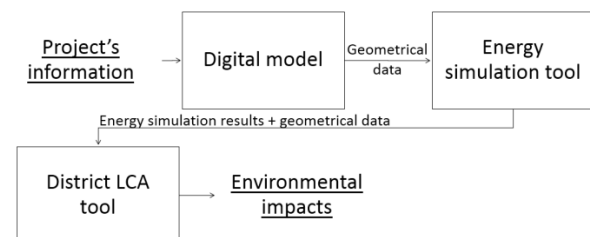

Fig. 2: Toolchain for simulation of energy and material contributors.

Firstly, a digital model of the urban project is created from available information (construction program, master plan...). Then, data is transmitted to the energy simulation tool: DIMOSIM [9] and COMFIE [10] have been used. And finally geometrical data, energy simulation results and data about outdoor spaces and utility networks (geometry, types) are compiled in the LCA tools which evaluate project environmental impacts: novaEQUER ([www.izuba.fr](http://www.izuba.fr)) and ELODIE ([www.elodie-cstb.fr](http://www.elodie-cstb.fr)).

For environmental assessment many Life Cycle Impact Assessment (LCIA) methods can be used leading therefore to different indicators [11].

### 2.3 Waste management simulation

Figure 3 presents the toolchain used to simulate the waste management system. Waste generated in the use phase in the district by residential, commercial and municipal activities is an input to the waste model. The system's function is to treat 1kg of waste generated by the district. Different treatment options (traditional or innovative) can be simulated.

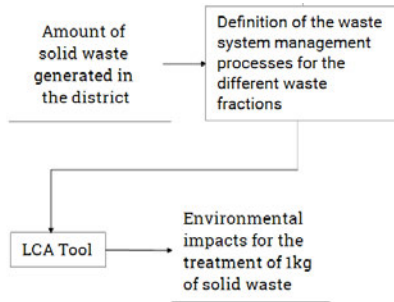

Fig. 3: Toolchain for waste LCA.

The waste system management is modelled from available information on the district regarding waste quantities, and existing processes in the territory. Sinoe database ([www.sinoe.org/](http://www.sinoe.org/)) was used to define the system. Data regarding inputs (materials, energy) and outputs (emissions of substances) for each waste process were project specific or generic (from Ecoinvent database, [www.ecoinvent.org/](http://www.ecoinvent.org/)).

As stated before, different impact methodologies can be used. The case study presented here relies on the Impact 2002+ [12] methodology.

## 2.4 Water management simulation

The approach is similar to waste management. The functional unit is the production of  $1\text{m}^3$  of drinking water, and the treatment of  $1\text{m}^3$  of wastewater during the use phase of the district. An urban water life cycle is presented in figure 4.

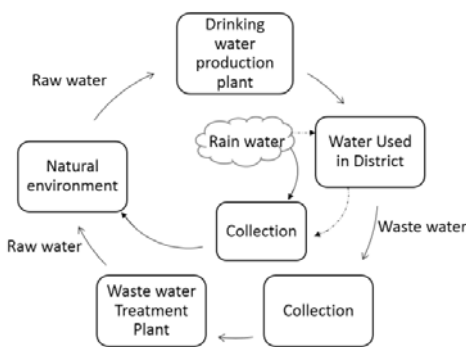

Fig. 4: Urban water life cycle.

The toolchain used for water management system LCA is presented in figure 5.

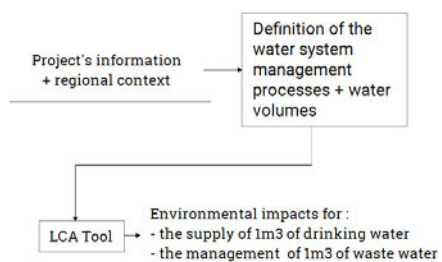

Fig. 5: Toolchain for water LCA.

Firstly, volumes of drinking water and associated wastewater generated in the district and the processes are defined thanks to the available

information about the project and its territory. Secondly, the life cycle inventory of every type of water production or treatment process is carried out using either specific available data or generic Ecoinvent data. Finally, impacts are assessed, for the work presented here we used the Impact 2002+ methodology, but other methodologies can be used [11].

## 2.5 Mobility simulation

Mobility associated with an urban project closely depends on its location at the regional level, both in terms of spatial organization of activities and configuration of transportation networks. Mobility simulation was therefore performed using a regional transportation model, MODUS, adapted for this study. It is based on the four-step formalism which is illustrated in figure 6.

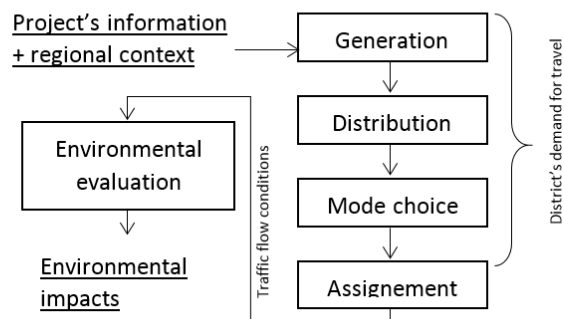

Fig. 6: Mobility simulation chain.

It is a classical transport model usually applied at the regional level for the peak-hour simulation. "Generation" allows the simulation of total in and out flows for a project given in terms of its program. "Distribution" allows for origin and destination matching at the regional level. "Mode choice" splits mobility demand among available transportation modes. "Assignment" corresponds to the route choice and determines congestion levels, mean speed and travel times. An additional step was added to the model to estimate energy consumption and pollutant emissions concerning individual trips associated with the project.

Adjustments were brought to the model to deal with mobility at the project's level (spatial refinement) and to estimate fuel consumption and pollutant emissions over a one-year period (scaling down for the off peak-hour periods and scaling up for the week and year ranges).

The environmental impact of mobility during the use phase was thus determined for energy, greenhouse gas and pollutant emissions indicators.

## 3 APPLICATION TO A CASE STUDY

The presented models have been applied to a case study of a 4 ha project including 25 buildings of different types (residential, offices...) located in the suburb of Paris (see figure 7).



Fig. 7: Project location in the Region of Paris.

While the project is in its early phase, the project managers' aim is to design and build a district following high environmental standards. To provide them with information about the project's performances, we ran simulations of the project's associated mobility, buildings and district energy consumptions and waste and water management on the entire life cycle of the district, as presented above. The main hypotheses, results and analyses of these studies are presented below.

### 3.1 Material and energy simulation results

In line with the project managers' objectives regarding sustainable development, we explored 4 construction scenarios:

- (i) Low energy buildings (LEB) [reference]
- (ii) Passive buildings (PB)
- (iii) LEB and 8000m<sup>2</sup> of photovoltaic (PV) panels to produce local electricity (LEB+PV)
- (iv) PB and 8000m<sup>2</sup> of PV panels (PB+PV)

To offer a comparison of these scenarios we used the toolchain presented in section 2.2. Main simulation hypotheses are summarized in table 1.

Occupation rate for each building type (occupants/m <sup>2</sup> floor area)	Collective housing = 0,032 ; Office Building = 0,083 ; Commerce = 0,138
Energy type for heating and hot water production	Natural gas
Length of time considered for the analysis (LCA)	100 years

Table 1: Main simulation hypotheses.

As indicated in section 2.2, many environmental aspects can be considered. In figure 9 we have presented as an example, simulation results for this specific case study regarding 7 environmental aspects.

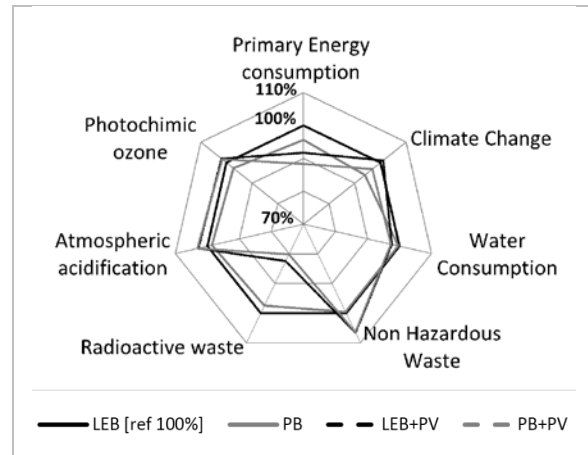

Fig. 9: Buildings LCA results.

As expected, no variant is optimal on all indicators. Nevertheless, if the project managers' main objective is to focus on the reduction of radioactive waste production or energy consumption, the results show that the 4<sup>th</sup> scenario (PB+PV) presents lower impacts than other studied options. At the same time, regarding climate change more progress could be achieved with 2<sup>nd</sup> (PB) option.

To help the interpretation further analysis could be provided through normalization of LCA results. Normalization makes it possible to translate impact scores for every impact indicator into relative contributions of the district to a reference situation [13].

### 3.2 Waste management simulation results

Two waste management scenarios were explored:

- (i) Collection and treatment within the territory's existing waste management system (including an industrial composting platform) [reference]
- (ii) Implementation of a local collective composting facility for organic waste

The different fractions of Municipal Solid Waste (MSW) and waste from activities are collected (1407 t/yr. in total) and sent to the following processes, similarly to the existing processes in the territory: incineration, landfill, composting, sort-in, drop-off centre. With exception to the drop-off centre and sorting centre modules that were created according to the data available in the SIETREM [14] activity report, data from Ecolnvent database was used. The LCA allocation method by system expansion is chosen, for secondary materials (i.e. paper, glass, wood, steel, compost etc.), leading to avoided burdens, or "credits". Impact 2002+ as chosen as the Impact Assessment method.

For this case study, results show that both scenarios have approximately the same impacts. Because an industrial composting platform is already in operation on the territory, environmental avoided burdens obtained with the implementation of a local collective composting



facility are not very significant. Therefore, in this case, investment in this kind of facility is not recommended.

**3.3 Water management simulation**

Table 2 presents explored scenarios for drinking water production and wastewater management.

	Reference scenario	Alternative
<b>Drinking water production</b>	Drinking water production from Annet sur Marne plant	Collection and reuse of rainwater for watering the gardens
<b>WW treatment</b>	Treatment in the existing WWTP (Saint Thibault des Vignes)	Treatment in a micro-WWTP (OrganicaTM)[14]

Table 2: Water management scenarios.

In the reference scenario, 352 m<sup>3</sup>/day are produced in the drinking water production plant to meet the district's needs. After its use 90% is sent to the WWTP, the last 10% being consumed or evaporated in the district. In the alternative scenario, the potential rainwater volume that can be collected in specific equipment implemented on the roofs of buildings is estimated to be 23 m<sup>3</sup>/day (then, only 329 m<sup>3</sup>/day of drinking water is produced).

Concerning drinking water production, results show that the reuse of rainwater for watering gardens is significantly beneficial if the rainwater tanks are reused or recycled in their end-of-life phase. Concerning wastewater treatment, both scenarios generate different impacts but neither appears to be the best solution. As described in section 3.1, further analysis could be provided through normalization of LCA results.

**3.4 Mobility simulation**

The project site is currently well connected to Paris with an existing RER line and is easily accessible by car, benefiting from a close highway. It is also located at one of the Grand Paris Express development sites related to the extension of the transit network. Several new metro lines will connect at the existing RER station, increasing its accessibility.

Land use at the project's level	Population 0.032hab/m <sup>2</sup> and split between active (72%) and non-active (28%); Jobs 0.041/m <sup>2</sup> for offices and 0.024/m <sup>2</sup> for retail
Land use at the regional level	IAU projections for 2030 at the Paris Regional level
Transportation network	Road – unchanged between 2010 and 2030; Transit – Grand Paris Express project, 2030

Table 3: Main mobility simulation hypotheses.

The main simulation hypothesis, summarized in table 3, pertain to land use (local and regional) and the transportation network. Although the

ontology differs between building and transport simulations concerning the buildings' occupation rate, we attempted to harmonize hypotheses related to buildings' occupation scenarios.

Simulations were performed during E. Vanhille's master's degree project [15]. Figure 10 shows results in terms of modal split (daily distance per mode associated with the project) and CO<sub>2</sub> emissions.

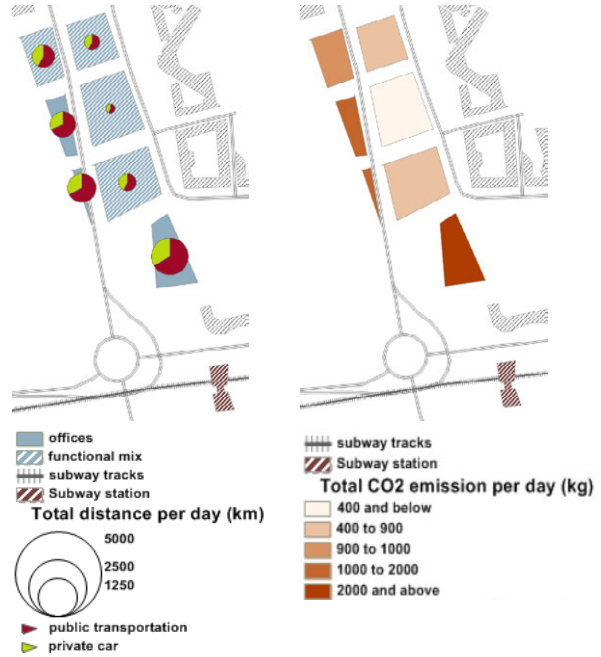

Fig. 10: Mobility simulation results: modal split and daily CO<sub>2</sub> emissions.

The main results can be summarised as follows:

- spatial refinement of the model allows to obtain results at the building's level;
- results are sensitive to the project's program: offices vs. mixed-use buildings;
- and to the local context: modal split and therefore CO<sub>2</sub> emissions vary with distance to the main RER station;
- and also to the regional context: modelling at the regional level allows to take into account transit ridership (the higher it is the lower per-passenger impacts are), road congestion (reduced speed therefore increased emissions) and fleet composition.

**4 DISCUSSION**

In order to bring substantial and objective arguments regarding their performances, the environmental assessment of districts should rely on systemic simulation combined with LCA of its main components (see figure 1). Models and tools presented here, already make it possible to simulate and evaluate individual or group of contributors of a district with a good precision level. However, these detailed simulations performed by field experts are partitioned and it is not yet possible to perform a systemic simulation of the district. Based on the observations emerging from the case study results, we

identified two major steps needed to achieve district systemic simulation:

- Harmonizing simulation hypotheses
- Harmonizing methodological choices

#### 4.1 Harmonizing simulation hypotheses

The different studies presented in section 3 reveal some inconsistencies in hypotheses between simulations:

##### (i) Foreground data harmonization

The occupation rates of buildings vary between simulations resulting from different practices between energy and transport simulation. To overcome this issue, we recommend creating a master model of usage scenarios concerning mobility, water, waste, energy and occupation in buildings.

##### (ii) Background data harmonization

For instance, simulations of water and energy both use weather data, focusing on rainwater in the first case and on thermal aspects (e.g. temperature...) in the second. In this case the use of consistent weather data is recommended to enhance the consistency of the study.

To harmonize simulation hypotheses, we recommend using a shared data dictionary containing all data that can be mutualized.

#### 4.2 Harmonizing methodological choices

Methodological harmonization aims to enhance interoperability of sectorial simulations in order to provide a comprehensive picture of a project performances. This work raised 3 main methodological harmonization issues:

##### (i) The local and global environmental impact simulations

For example, in this work the mobility simulation was not combined with LCA. Indeed, focus was on greenhouse gases and some other emitted pollutants and their integration in the LCA is essential in further work. For this study, first adjustments were brought to the mobility model to deal with mobility at the project's level (spatial refinement) and to estimate fuel consumption and pollutant emissions over a one year period (scaling down for the off peak-hour periods and scaling up for the week- and year- ranges). Work is in progress in order to use these mobility simulation outputs in an LCA based simulation.

##### (ii) LCIA method to be used

LCIA methods normally assign a factor to each elementary flow in an inventory table to provide LCA results through impact categories. Based on methodological debates, different LCIA methods and thus different impact categories can be implemented.

##### (iii) The methods for environmental impact allocation in the case of multifunctional systems

Two examples of multifunctional systems possibly encountered in districts are:

- A building's main function is to host human activities (residential, business or commercial) but buildings can also generate energy sent to the electric network.
- Waste treatment processes are often multifunctional as energy or secondary raw materials can be generated.

This consideration raises two questions: How should the environmental impacts of these processes be allocated to the different products (or functions) involved? Which processes belong to the product system studied and which do not? Different views disagree on the way to model multifunctional systems, we can mention cut-off and substitution approaches [16], [17].

Today, no final decision has been taken regarding these methodological choices. Further research and discussion of these questions are necessary to harmonize methodological choices.

## 5 CONCLUSION

The work and simulations conducted here bring substantial arguments regarding the performances of the project under study. The main simulation findings are listed below:

Concerning energy and material contributors in buildings, simulation results bring a lot of information. To help their interpretation further analysis could be provided through the normalization of LCA results.

Regarding drinking water management: simulation results show that harvesting rain water rather than using drinking water for watering gardens is environmentally beneficial if rainwater tanks are reused or recycled at their end-of-life.

Regarding waste management, simulation results demonstrate, in this particular case, that investing in local composting systems is not relevant from an environmental point of view.

Finally, the environmental impact of mobility during the use phase was thus determined for energy, greenhouse gas and pollutant emissions indicators.

Based on observations emerging from the case study, we present prevailing issues that should be addressed in priority in order to improve systemic simulation and environmental evaluation of districts:

- (i) Harmonize simulation hypotheses, pertaining to the project (e.g. occupancy scenarios) or to background data needed in simulations (e.g. weather data)
- (ii) Harmonize methodological choices to be able to combine simulation results in order to measure the relative contribution of each district contributor (energy, water, waste...) to the total impacts of the district

In addition to these priorities, further enhancements could also improve assessment of district performances, we especially identify:

- Articulate LCA with local impact studies for instance concerning sanitary impacts related to air pollution from vehicles and buildings, local studies on air pollution transfer are essential
- Evaluate economic and social indicators to perform district global assessments
- Question the representation and associated interpretation of results. To answer this problem, the use of 3D digital model is worth considering

## 6 ACKNOWLEDGMENTS

The authors would like to thank EPA - Marne-la-Vallée for providing us with information and data about their project and allowing us to study it. For land use and transport simulations, we adapted the DRIEA's MODUS model: we thank this organization for providing us with regional data and initial model parameters. Finally, results presented here were initiated under the Efficacity (www.efficacity.com). We thank the French National Agency for Research (ANR) for partially supporting Efficacity's programs.

## 7 REFERENCES

1. Herfray, G. and B. Peuportier, "Life Cycle Assessment applied to urban settlements," in *Sustainable Building Conference*, 2010.
2. N. Schioppa N., et al., "A hybrid methodology for the environmental assessment of anthropic systems in urban areas," presented at the Sustainable Building, 2014.
3. Lotteau, M., et al., "Critical review of life cycle assessment (LCA) for the built environment at the neighborhood scale," *Build. Environ.*, vol. 93, Part 2, pp. 165–178, Nov. 2015.
4. Loubet P., et al., "WaLA, a versatile model for the life cycle assessment of urban water systems: Formalism and framework for a modular approach," *Water Res.*, vol. 88, pp. 69–82, Jan. 2016.
5. Clavreul, J., et al., "An environmental assessment system for environmental technologies," *Environ. Model. Softw.* vol. 60, pp. 18–30, Oct. 2014.
6. Loiseau, E., et al., "Implementation of an adapted LCA framework to environmental assessment of a territory: important learning points from a French Mediterranean case study," *J. Clean. Prod.*, vol. 80, pp. 17–29, Oct. 2014.
7. Popovici, E. and B. Peuportier, "Using life cycle assessment as decision support in the design of settlements," in *Proceedings of the 21st Conference on Passive and Low Energy Architecture*, 2004, pp. 19–22.
8. Association pour la Haute Qualité Environnementale, "HQE Performance Règles d'application pour l'évaluation environnementale des bâtiments, version du 22/06/2012 pour le test HQE Performance 2012." 2012.
9. Riederer, P., et al., "Development of a simulation platform for the evaluation of district energy system performances," presented at the Fourteenth IBPSA Conference, Hyderabad, 2015.
10. Peuportier, B. and I. B. Sommereux, "Simulation Tool with its expert interface for the thermal design of multizone buildings", *Int. J. Sol. Energy*, vol. 8, no. 2, pp. 109–120, Jan. 1990.
11. Hauschild, M., et al., "Recommendations for Life Cycle Impact Assessment in the European context - based on existing environmental impact assessment models and factors (International Reference Life Cycle Data System - ILCD handbook)," Publications Office of the European Union, EUR - Scientific and Technical Research Reports, 2011.
12. Jolliet, O., et al., "IMPACT 2002+: A new life cycle impact assessment methodology," *Int. J. Life Cycle Assess.*, vol. 8, no. 6, pp. 324–330, Nov. 2003.
13. Sleeswijk, A. W., et al., "Normalisation in product life cycle assessment: An LCA of the global and European economic systems in the year 2000," *Sci. Total Environ.*, vol. 390, no. 1, pp. 227–240, Feb. 2008.
14. Syndicat mlxte pour l'Enlèvement et le Traitement des REsidus Ménagers, "Rapport annuel d'activités 2013 - Sietrem," 2013.
15. Vanhille, E., "Modélisation et évaluation environnementale de la mobilité. Application à un projet d'aménagement de la Cité Descartes Elargie", PFE ENPC, 2015.
16. Frischknecht, R., "LCI modelling approaches applied on recycling of materials in view of environmental sustainability, risk perception and eco-efficiency," *Int. J. Life Cycle Assess.*, vol. 15, no. 7, pp. 666–671, Jun. 2010.
17. European Union, "Commission Recommendation of 9 April 2013 on the use of common methods to measure and communicate the life cycle environmental performance of products and organisations", Official Journal of the European Union, vol. 56, 4 May 2013.





## Expanding Boundaries: Systems Thinking for the Built Environment

### COMBINING GIS DATA SETS AND MATERIAL INTENSITIES TO ESTIMATE VIENNA'S BUILDING STOCK

F. Kleemann<sup>1\*</sup>, J. Lederer<sup>1</sup>, H. Rechberger<sup>2</sup>, J. Fellner<sup>1</sup>

<sup>1</sup> Christian Doppler Laboratory for Anthropogenic, Technische Universität Wien,  
Karlsplatz 13/226.2, 1040 Wien, Austria

<sup>2</sup> Institute for Water Quality, Resource and Waste Management, Technische Universität  
Wien, Karlsplatz 13/226.2, 1040 Wien, Austria

\*Corresponding author; e-mail: fritz.kleemann@tuwien.ac.at

#### Abstract

The work presented describes a method to analyse the current material stock in buildings in the city of Vienna as a basis for estimating current and future demolition waste available as potential secondary raw material. The assessment of the material stock in buildings is carried out through combining data about the material composition of different building categories and information about the building structure. Data about the material composition of buildings is generated by investigating single buildings (case studies), analysing construction files of demolished buildings, evaluating available documents of newer buildings (tender and billing documents, LCA data), and through literature review. As a result, specific material intensities for different building categories (construction period/ utilization) are merged in a database which is continuously enhanced with ongoing research. In order to characterize the building structure of Vienna, GIS data from different municipal departments are used. A data set providing information about gross volume, construction period, and utilization is generated. By combining information about the building structure and the specific material intensities of different building categories, the overall material stock embedded in buildings in Vienna was calculated to be 380 million tons, which equals 210 tons per citizen. Combining the data about the embedded materials with information about demolition activities will allow estimating current and future amounts of demolition waste and thus materials potentially available for recycling. Knowledge about the material stock and flows of buildings is an important step towards closing material cycles in demolition waste management.

#### Keywords:

building material; building stock; geographic information systems (GIS); industrial ecology; urban metabolism; urban mining

#### 1 INTRODUCTION

Recent years have shown an increasing interest in the building stock as a research object (Kohler and Hassler, 2002). Different studies have determined the gross volume, the built-in materials, and the age as well as renovation intervals of buildings in order to estimate the demand for heating and cooling of buildings or renovation requirements of old structures. Within the life-cycle of a building, all these examples can be allocated to the use phase. A different perspective on the building stock is to focus on the end-of-life phase, particularly the projection of

the quantity and quality of construction and demolition wastes (CDW). This approach considers the building stock as a future anthropogenic resource deposit for secondary raw materials (Bergsdal et al., 2007; Hashimoto et al., 2009).

The built environment in Austria has only been estimated on a national level so far using statistical data (Stark et al., 2003). The chosen top down approach combines different data on the use of construction materials (mineral, organic, metallic). Even though the use of statistical data sets, as utilized in most

international studies, allows determining the overall stock size as well as the gross-generation of CDW, localizing material stocks and sources of CDW is not possible. The latter however is of major importance for the management of these wastes, as their recycling (except for metals) or disposal has to take place within the region of generation (distance of 20 to 40 km), as otherwise transportation costs would be too high. In this work the spatial information of the built environment has been added by employing GIS (geographical information system) data.

The study at hand was carried out in Vienna, the capital city and cultural and economic centre of Austria with about 1.8 million residents (representing almost one quarter of the national population). It presents an approach for analysing both the building structure and the material stock in buildings in Vienna. The building structure is analysed by combining different GIS data sets, which allows localizing different building categories. Data on the material intensity of different building categories, including bulk materials (e.g. minerals) and relevant materials in lower concentration (e.g. wood, plastics, metals, asbestos) is generated through various sources and approaches, ranging from the analysis of documents and on-site investigations to the review of relevant literature. The study aims at mapping information about the material stock in buildings in the city of Vienna as a basis for efficient resource management such as projecting the flow of wastes and secondary raw materials from demolition activities in the building sector.

## 2 METHOD

The present study combines different approaches to analyse the building structure in Vienna with regard to size (gross volume – GV), construction period, and utilization, as well as to generate a database about the material intensities (kg/m<sup>3</sup> GV) of different building categories (differentiated by construction period and utilization). Subsequently, data on the building structure and material intensities of different building categories are combined to assess and localize the material stock in all buildings in Vienna.

### 2.1 Building structure

The aim here is to generate a city-wide GIS data set which comprises information about gross volume (GV), construction period, and utilization for each building. To achieve that the following steps are conducted:

1. A map of the municipal department for surveying includes information about area and relative height\* of each building/building part in Vienna. The data is based on terrestrial measurements.

2. To assign information about construction period and utilization a map of the municipal department for city planning and land use is spatially joined with the above mentioned map.
3. Existing data gaps with regard to construction period and utilization for some areas of the city are filled using information of the municipal department for city development and planning (for construction period) as well as the general zoning plan (for utilization).
4. Data about new buildings (built after 2008) is added through data administrated by the municipal building and inspection department.

*\*The relative height is the distance between ground level and eaves. Therefore, the average height of roofs and basement floors was added based on expert judgements. Depending on the building categories different additional heights were assessed.*

Altogether 15 categories, differentiating between construction period and utilization of buildings, are distinguished: 5 different construction periods (before 1918, 1919-1945, 1946-1976, 1977-1996, after 1997), which correspond to the available GIS data, and 3 strongly aggregated categories for utilization (residential, commercial, industrial).

### 2.2 Material intensities

As the material composition of buildings varies depending on utilization and construction period, specific material intensities per GV can be determined and assigned to different building categories.

As described in Kleemann et al. (2014) demolition projects in Vienna are investigated and built-in materials are quantified prior to the demolition of the building, based on the analysis of available documents (construction plans, expert's reports) and on-site investigation, including selective sampling. During the on-site investigation, data on built-in materials are collected through labour intensive measurements and selective sampling (weighting, and measuring of components such as windows, doors, partitions, ceiling suspensions, floor and roof constructions, wires, pipes, etc.). Based on the data collected, information about the different built-in materials is aggregated and the mass is calculated based on volume, area or number of the particular material as well as on data on its specific density or weight.

In order to increase the sample size of buildings investigated, construction files of buildings reported to be demolished in the city of Vienna are analysed. Depending on the quality of the documents, building materials used for wall, ceiling and sometimes also for roof or floor construction can be determined. Data gaps,

mostly regarding low volume materials (installations, fittings, windows) are filled by using specific material intensities obtained from the case studies analysed in detail.

In order to complete the data set on the specific material intensities with regard to newer buildings, which are rarely demolished, existing data on the material composition of these buildings is utilized. This material data is derived from life cycle assessments (LCA), tendering documents, construction plans and accounting documents of recent building projects. To put the material intensities generated in context with other studies carried out, literature data on the material composition of buildings are utilized.

### 3 RESULTS AND DISCUSSION

#### 3.1 Building structure

The overall GV of buildings in Vienna is about 860 million m<sup>3</sup>, with a large share being used for residential purposes (540 million m<sup>3</sup> GV). With regard to the age of the building stock, it is noticeable that the largest share of buildings was constructed before 1918 (290 million m<sup>3</sup> GV). Figure 1 illustrates the distribution of the GV among the different building categories.

#### 3.2 Material intensities of different building categories

The combination of all data collected and analysed resulted in specific material intensities for different building categories. The general structure of the data and aggregated results are shown in Table 1. The material categories (mineral, organic, metal) are further divided in specific materials such as concrete, bricks, glass, asbestos, wood, plastics, bitumen, iron, aluminium or copper.

Not surprisingly Table 1 indicates a dominant share of mineral materials within buildings. In contrast organic materials and metals occur in

rather low concentrations. Newer buildings tend to have higher metal contents (mainly because of reinforcement steel) and a lower content of organic material (mainly due to a decreasing usage of wood). No information could be gathered for industrial buildings built after 1997 using the described approach. For the calculation of the material stock in buildings, values from the previous time period were used.

#### 3.3 Overall material stock and its spatial distribution

By combining information about the building structure and the specific material intensities of different building categories, the overall stock in buildings in Vienna (380 million t) was calculated. Around 96% of the material is mineral, mainly represented by concrete (150 million t), and bricks (130 million t) and mortar (50 million t). Organic materials and metals hold a small share (4%) of the overall material stock in buildings, of which wood and steel are the dominant materials (Figure 2)

The material stock in buildings per capita is about 210 t. As Vienna is an economic centre in Austria with around 250,000 commuters, a part of the building stock also services people residing outside Vienna. From a resource and waste management perspective, the spatial distribution of materials is of interest. This information allows predicting CDW arising through the demolition of buildings as well as projections of secondary raw materials arising from C&D activity on a municipal level. Combining GIS data with specific material intensities further allows the establishment of a resource cadastre, which illustrates the spatial distribution of materials throughout the city. Figure 3 shows the material intensity of buildings in Vienna expressed as mass of wood per built-up area of the buildings.

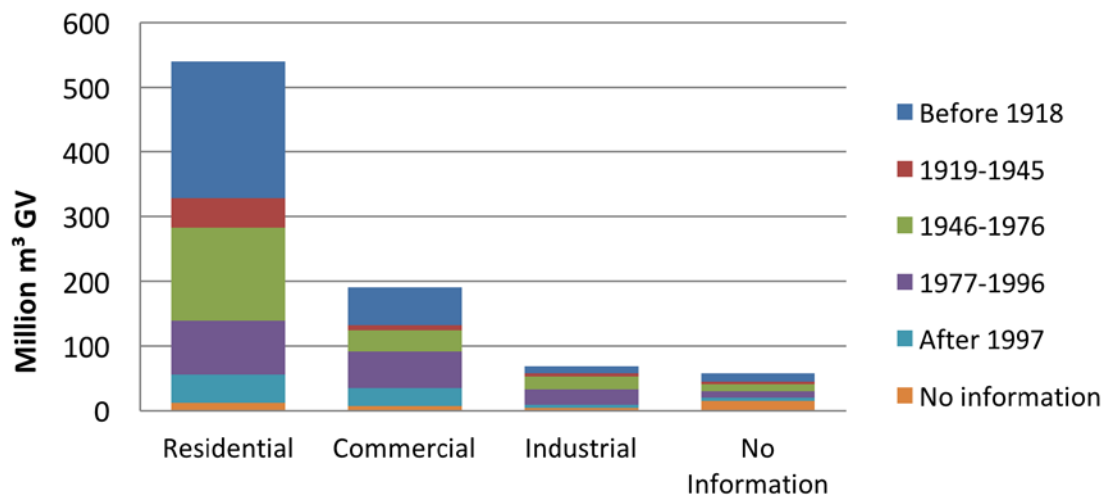

Figure 1: Distribution of GV in Vienna among the different building categories (kg/m<sup>3</sup> GV)

Period of construction	Utilization	Mineral materials	Organic materials	Metals	Total
Before 1918	residential	390	19	3,1	410
	commercial	430	3,7	4,4	440
	industrial	280	5,8	8,8	300
1919-1945	residential	410	13	4,8	430
	commercial	340	7,1	6	360
	industrial	320	28	5,8	350
1946-1976	residential	430	6,5	7,3	450
	commercial	350	7,6	5,7	360
	industrial	340	7,6	13	350
1977-1996	residential	430	6,7	7,1	460
	commercial	380	1	13	400
	industrial	170	1	15	180
After 1997	residential	380	10	15	410
	commercial	320	5,7	10	340
	industrial	290	5,6	13	310

Table 1: Specific material intensities of different building categories (Kleemann et al., 2016).

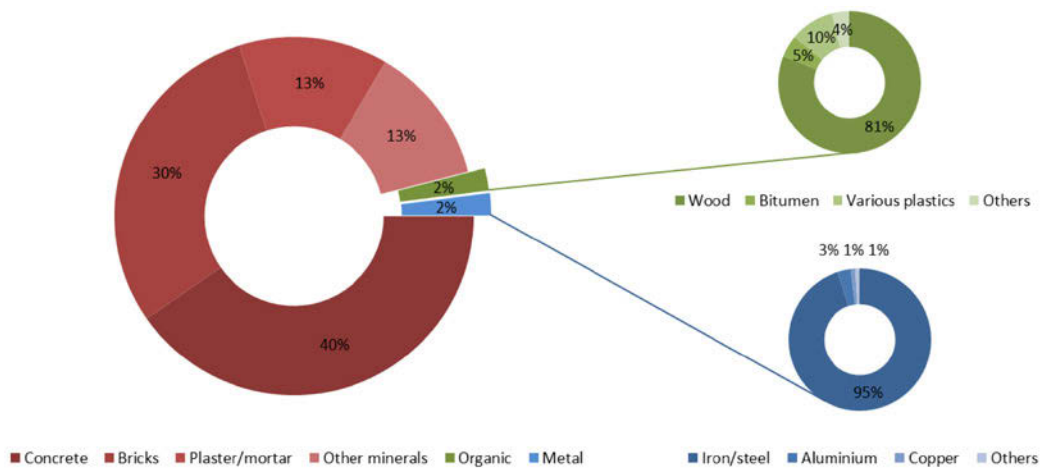

Figure 2: Material composition of Vienna's building stock (Kleemann et al., 2016).



Figure 3 Spatial distribution of wood in the city of Vienna ( $\text{kg}/\text{m}^2$  built-up area).



#### 4 CONCLUSIONS AND OUTLOOK

The results demonstrate that it is possible to characterize the material composition of the building stock by combining available GIS data sets with collected data on the material intensity of different buildings categories. Combining the generated data about the material stock with information about the demolition activity in Vienna will further allow assessing the amount and composition of CDW and thus also the materials potentially available for recycling. The data basis on specific material intensities of different building types will be improved with ongoing research in this field.

#### 5 REFERENCES

1. Bergsdal, H., Bohne, R.A., Brattebø, H., 2007. Projection of Construction and Demolition Waste in Norway. *Journal of Industrial Ecology* 11, 27-39.
2. Hashimoto, S., Tanikawa, H., Moriguchi, Y., 2009. Framework for estimating potential wastes and secondary resources accumulated within an economy—A case study of construction minerals in Japan. *Waste management* 29, 2859-2866.
3. Kleemann, F., Lederer, J., Aschenbrenner, P., Rechberger, H., Fellner, J., 2014. A method for determining buildings' material composition prior to demolition. *Building Research & Information*, 1-12.
4. Kleemann, F., Lederer, J., Rechberger, H., Fellner, J., 2016. GIS-based analysis of Vienna's material stock in buildings. *Journal of Industrial Ecology* (in press).
5. Kohler, N., Hassler, U., 2002. The building stock as a research object. *Building Research & Information* 30, 226-236.
6. Stark, W., Vogel-Lahner, T., Frühwirth, W., 2003. *Bauwerk Österreich—Endbericht*. GUA - Gesellschaft für umfassende Analysen GmbH, Wien.



## Expanding Boundaries: Systems Thinking for the Built Environment



### A GIS-BASED APPROACH FOR THE ENERGY ANALYSIS AND LIFE CYCLE ASSESSMENT OF URBAN HOUSING STOCKS

A. Mastrucci<sup>1\*</sup>, A. Marvuglia<sup>1</sup>, E. Benetto<sup>1</sup>, U. Leopold<sup>1</sup>

<sup>1</sup> Luxembourg Institute of Science and Technology (LIST), 41 rue du Brill,  
L-4422 Belvaux, Luxembourg

\*Corresponding author; e-mail: [alessio.mastrucci@list.lu](mailto:alessio.mastrucci@list.lu)

#### Abstract

Buildings are responsible for 40% of the final energy use and one third of greenhouse gas emissions in Europe. At the city scale, a quantitative assessment of the environmental impact of buildings is essential to support sustainable energy policies. Life Cycle Assessment (LCA) has been widely used to assess building related environmental impacts; however, its extension to the urban scale is still hampered by several operational challenges. Coupling LCA and Geographic Information Systems (GIS) has been identified as a promising solution but developments are still needed.

This paper presents an automated approach for the energy modelling and LCA of urban housing stocks based on GIS. The main steps of the approach are the following: (i) GIS-based building stock characterization; (ii) automated building-by-building energy analysis; (iii) Environmental impact calculation via LCA. The approach was applied to the test case city Esch-sur-Alzette (Luxembourg) to assess the potential environmental impact reduction driven by housing retrofitting.

Results were provided building-by-building and displayed as maps for improved communication. An energy savings potential of 35.3% and a Global Warming Potential (GWP) reduction of 30.8% were calculated as results of retrofitting. The average contribution of the retrofitting stage on the residual life of the building stock is 4 to 10% of the GWP, depending on the building type.

The study provided one of the first models able to perform a fully-fledged LCA of buildings at the urban scale in a bottom-up fashion. The results are meant to support local authorities in setting priority strategies for environmental impact reduction.

#### Keywords:

Building stocks; Retrofitting; Urban scale; Life Cycle Assessment; Geographical Information Systems

## 1 INTRODUCTION

Buildings are responsible for more than 40% of the global energy use and one third of greenhouse gas emissions in Europe [1]. The environmental impact of buildings has been identified as mainly due to space heating, domestic hot water and construction works [2].

Many studies focused on the assessment of the building energy demand and energy savings potential at the city scale [3,4], to support energy efficiency and carbon mitigation actions planning. However, most of them lacked a life cycle perspective that could lead to an overestimation

of environmental gains for refurbishment options [5] due to the omission of other life cycle stages (e.g. production of building materials).

Life Cycle Assessment (LCA) is a largely used methodology to account for building related environmental impacts [6,7]. In recent times, interest started to arise around the LCA of buildings at the urban scale [8,9]. Integrating Geographic Information Systems (GIS) with building stock modelling has been identified as an effective way to provide a link between building statistics and spatial location of different building types [5]. Nevertheless, coupling LCA and GIS is still challenging due to several

operational development needs [10], including software interoperability, data storage and processing, computation time reduction.

This paper presents an automated approach for the energy modelling and LCA of urban housing stocks based on GIS. The operational objectives are the following:

- (i) Characterization of the housing stock of one entire city by GIS and statistical data collection, processing and storage in a spatio-temporal database
- (ii) Energy analysis of the building stock running an automated building-by-building model
- (iii) Environmental assessment of residential buildings retrofitting using LCA

The city of Esch-sur-Alzette (Luxembourg), counting about 13'000 housing units, was used as a case study to test the methodology.

## 2 DATA AND METHODS

### 2.1 Dataset

The main geospatial dataset was provided by the Municipality and includes laser scanner data (LiDAR) and building footprints data. A Digital Surface Model (DSM) and Digital Terrain Model (DTM) were generated from the LiDAR data to obtain information on the height of buildings. The building footprint vector file contains attributes such as the period of construction and the type of building (e.g. single-family or multi-family house).

In addition, complementary information is needed for the characterisation of materials and building components. Thermal properties of materials were obtained from the standard DIN 4108-4:2013 [11]. Lacking building libraries specific for Luxembourg, building envelope components and technical systems were characterised based on statistics, technical standards, regulations [12], building libraries for neighbouring countries [13] and previous studies [14,15] and interviews with local experts. A set of reference building elements and components and their share in the stock were consequently identified for every housing type and period of construction. U-values were maintained consistent with national reference values for existing buildings [16]. The current refurbishment state of the buildings was also taken into account by defining a share of refurbished buildings per period of construction according to the building permits register of the city complemented with national statistics information.

### 2.2 Building stock characterization

The characterisation of the residential building stock was carried out in two steps [14]. First, geometric characteristics (outer walls area, roof area, floor surface) were computed building-by-building across the city by automated geo-processing of the previously described spatial dataset in GRASS GIS [17]. Second, the

reference building elements and components were distributed among real buildings based on their identified share in the stock and depending on housing type and period of construction. Retrofit operations were defined in accordance with the current national regulation requirements for the U-value of building envelope elements [12] and included: window replacement and insulation of outer walls, roof, and ground floor.

A spatial database was developed in PostgreSQL - PostGIS [18,19] to stock and process the collected data. Building elements and components, as well as retrofit operations, were associated to single buildings using specific queries in the database (see [14] for detailed description).

### 2.3 Energy analysis

The model for the energy analysis of the building stock is based on the national Luxembourg regulation for the energy performance of buildings [12]. The space heat demand is calculated on a monthly basis using equation (1):

$$Q_{h,M} = Q_{tl,M} + \eta_M \cdot (Q_{s,M} + Q_{i,M}) \quad (1)$$

where  $Q_{h,M}$  is the monthly heat demand for space heating in  $kWh$ ,  $Q_{tl,M}$  is the monthly heat losses for ventilation and transmission in  $kWh$ ,  $\eta_M$  is dimensionless heat gain utilisation factor,  $Q_{s,M}$  and  $Q_{i,M}$  are the monthly solar and internal heat gains in  $kWh$ . Simplifications for existing buildings were applied in accordance with the national methodology regarding thermal bridges, shading calculation, efficiency of heating and domestic hot water systems.

The model was implemented in a script in *R* [20] connected to the building database to automate the calculation for buildings across the city for the current state and after the implementation of retrofitting measures.

### 2.4 Life cycle assessment

A LCA of buildings retrofitting at the urban scale was carried out according to the standards EN 15643-2:2011 [21] and EN 15978:2011 [22] to quantify the environmental impact reduction potential. The software SimaPro 7.3.3 [23] was used at this aim.

The effect of retrofitting was assessed by simulating the implementation of measures consistent with every period of construction and type of building, as described above. The environmental impact of buildings was calculated for their residual life cycle respectively with and without the implementation of retrofitting measures. The analysis included the following life cycle stages:

- Retrofitting stage: production and transport of building material to be employed
- Operational stage: energy consumption for space heating and domestic hot water

The functional unit selected is the entire housing stock in the city; the results calculated are then rescaled to 1 m<sup>2</sup> of floor surface. Residual service life of buildings was identified according to previous studies [15]. The foreground inventory data were obtained from the building stock characterization and the energy analysis, the background inventory data from the database Ecoinvent 2.2 [24].

The method CML 2 baseline 2000 [25] and a range of impact categories were selected for the evaluation of the lifecycle impacts according to EN 15643-2:2011 [21]: Abiotic Depletion Potential (ADP), Acidification Potential (AP), Eutrophication Potential (EP), Global Warming Potential (GWP), Ozone Depletion Potential (OPD) and Photochemical Ozone Creation Potential (POCP). The indicator GWP was selected to show results in this paper because: 1) it is relevant for the construction sector [9]; 2) it makes results comparable with other studies at large scale, which mostly use GWP as impact category.

The normalization step translates all the impacts belonging to different categories into the same metrics, i.e. the number of equivalent inhabitants that would generate those impacts. Normalization according to the method CML Europe West 1995 was carried out for direct comparison among impacts of different categories and identification of categories with the highest impacts. Some of the results are shown here in terms of GWP due to the importance of this impact category and for comparability with similar studies.

Results were produced for the expected residual service life and then expressed on a yearly basis and per floor area unit. An extrapolation to the entire building stock was finally performed by matching impacts with buildings across the city.

### 3 RESULTS

#### 3.1 Energy analysis

Results of the energy need calculation for the residential buildings of Esch-sur-Alzette are shown in Fig. 1 per type of housing (Single-family detached houses SFH, Row-houses RH, Multi-family houses MFH) and period of construction (<1970, 1970-95, >1995). The energy intensity

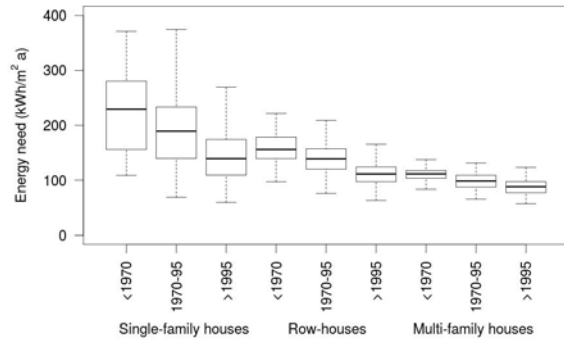

Fig. 1: Distribution of energy intensity for space heating and domestic hot water of residential buildings in Esch-sur-Alzette per type of building and period of construction.

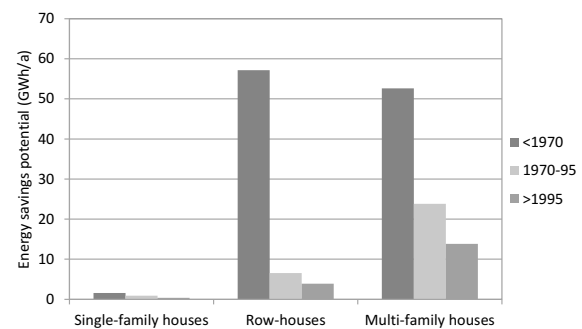

Fig. 2: Total energy savings potential after retrofitting residential buildings in Esch-sur-Alzette per type of building and period of construction.

per unit of floor area (kWh/m<sup>2</sup>a) highly depends on both period of construction and type of buildings, being higher for older buildings and for single family houses. The variability of energy needs within the same category of buildings is also highly dependent on the type of buildings. SFH have higher variability, due to a range of geometrical shapes resulting in different compactness of the building and different amount of heat losses.

The total energy need for space heating and domestic hot water of the housing stock calculated at the city scale in the current state amounts to 248.4 GWh/y. Results were validated against aggregated measured consumption data for natural gas provided by the local energy supply company. The comparison showed a good agreement, resulting in a difference within 10% between the calculated and measured consumption.

Results of the energy savings potential calculation at the city scale are shown in Fig.2 per housing type and period of construction. The highest energy savings potential is attributable to RH and MFH built before 1970, amounting to respectively 35.6% and 32.8% of the total. SFHs potential for retrofitting is the lowest due to their limited number. The energy savings potential for retrofitting the entire residential stock is 87.7

GWh/y, corresponding to 35.3% of the current energy consumption.

### 3.2 Life cycle assessment

This section presents the results of the LCA of residential building retrofitting across the city of Esch-sur-Alzette.

The average yearly GWP per floor surface unit was estimated for different types of housing and periods of construction without and with the implementation of retrofitting measures, taking into account the entire residual service life (Fig.3). A substantial GWP reduction is achievable by retrofitting buildings constructed before 1995. The GWP reduction potential is higher for older buildings (from 33% to 45% for buildings before 1970), due to the effect of building envelope insulation. For buildings after 1995 benefits are minor or even null after including the impact of the retrofitting stage. Looking at retrofitted buildings, the operational stage largely prevails over the retrofitting stage in a life cycle perspective. Nevertheless, the retrofitting stage accounts for 4% up to 10% of the GWP depending on the housing type.

Fig. 4 shows the results of the normalization step. Among the selected impact categories, ADP and GWP emerged as the ones with higher environmental impact while the others appeared as less important. The environmental impact reduction potential determined by retrofitting significantly differs among the considered impact categories. The average reduction potential is similar for ADP, GWP, and ODP (from 30.8% to 32.6%). The impact reduction potential is lower for AP and POCP, while an increase is observed for EP. At the same time, the impact categories with higher impact reduction potential are characterized by a lower contribution of the retrofitting stage to the total environmental impact, ranging from 6.5% for ADP to 8.6% for GWP. In contrast, the average contribution of the retrofitting stage to the total environmental impact is the highest for AP (35.1%) and EP (47.1%).

Results were finally aggregated at the city scale and displayed as maps for decision support. Fig.4 shows, as an example, the GWP reduction potential by retrofitting buildings at the district level. Greater GWP reduction potential was found for districts next to the city centre as a result of the interaction between urban density, housing type and geometry, age and refurbishment state of buildings. At the city scale, the total estimated yearly reduction potential is 18.3 kt CO<sub>2</sub> eq., corresponding to 30.8%.

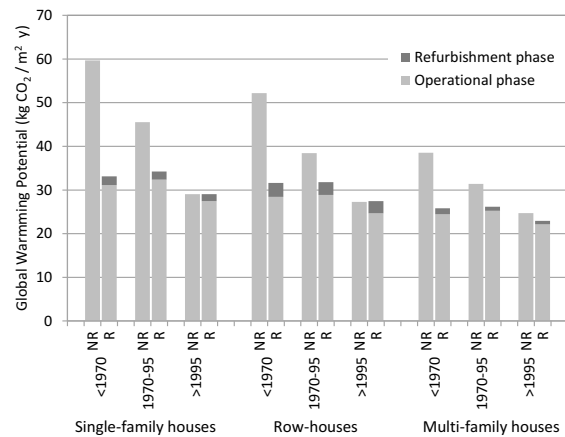

Fig. 3: Average GWP of residential buildings per floor area unit per type and period of construction without (NR) and with (R) implementing retrofitting measures in Esch-sur-Alzette.

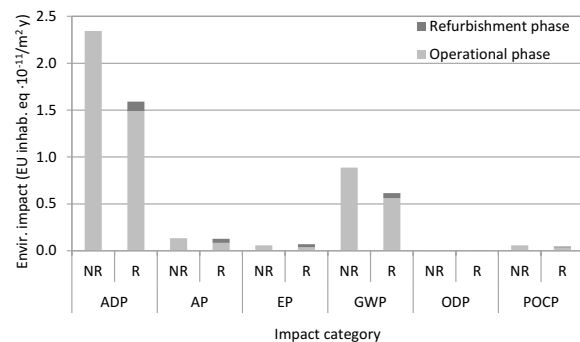

Fig. 4: Average normalized environmental impact of residential buildings per floor area unit without (NR) and with (R) implementing retrofitting measures in Esch-sur-Alzette.

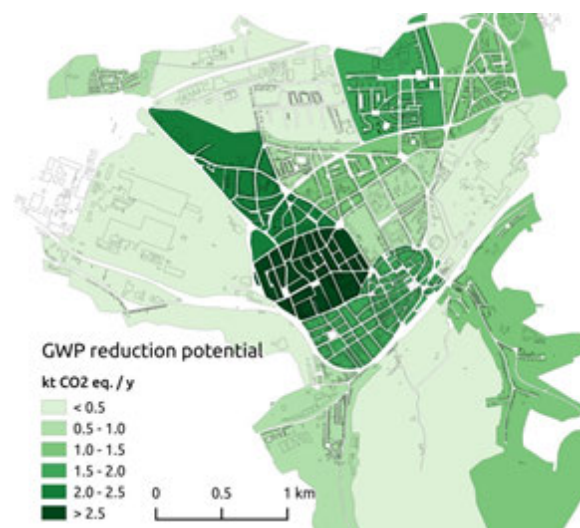

Fig. 5: Map of the GWP reduction potential of residential buildings in Esch-sur-Alzette after implementing retrofitting measures.

#### 4 DISCUSSION

This study provided one of the first efforts towards a fully-fledged LCA of buildings at the urban scale in a bottom-up fashion. The results are meant to support local authorities and city planners in setting priority strategies for energy savings and environmental impact reduction.

The approach is innovative compared to other commonly used approaches, e.g. *archetypes* [3,15], for the integration of GIS, energy modelling and LCA. GIS made it possible to take the geometry into account building-by-building with far higher precision and in a completely automated way. In particular, GIS processing provided an estimation of the area of outer building envelope elements such as walls and roof and to further distinguish walls in common between adjacent buildings from outer walls. The development of a spatio-temporal database allowed for the automatic delivery of input data for the energy and LCA models and their aggregation at the targeted level (building element/component, building, and city). In addition, the spatial dimension is explicitly taken into account and the framework is flexible for data update and application to other contexts.

However, the approach is affected by some limitations and assumptions. Developing a building stock LCA model at the urban scale is challenging for the number of buildings involved and the limited information available, especially regarding building materials, state of renovation, building usage and residual service life. As a consequence, several assumptions were made based on statistical data, national standards, regulations and previous studies. Uncertainty and sensitivity analysis will be addressed in a future step to study error propagation.

The study provided an estimation of the environmental impact reduction potential achievable by retrofitting the outer envelope of residential buildings across one city. This is to be considered as a theoretical figure as it does not include the actual rate of retrofitting implementation, nor cost-effectiveness aspects. The use of a simplified energy model in semi-steady state is justified as the study is limited to residential buildings and space heating demand evaluation. More complex dynamic models should be applied for the assessment of buildings with function other than residential and cooling demand estimation. Concerning the retrofitting stage, the disposal and waste treatment of existing building materials and components removed during the operations were currently neglected. Other stages of the buildings' life cycle, including the end-of-life stage, will be further included in a future step.

Another crucial point is results validation. Whilst we compared results of the energy consumption modelling in the current state against measured

data, it is not completely possible validating results concerning energy savings potential and environmental impact of material production and retrofitting operations.

In spite of the additional work needed to provide more robust results, this study proved the effectiveness of the developed framework for the LCA of urban building stock and the evaluation of the effect of retrofitting.

#### 5 CONCLUSIONS

A GIS-based LCA approach was developed to evaluate the environmental impact of urban building stocks and the reduction potential driven by retrofitting. The methodology was implemented and tested for an entire city in Luxembourg and provided promising results for the set up and development of building retrofitting scenarios.

Further developments will extend the evaluation to all the stages of building life cycle and to other cities in Luxembourg and other European countries. The models will be implemented in the web-based open-source platform iGUESS [26] to support decision in sustainable urban planning.

#### 6 ACKNOWLEDGMENTS

This study is part of the postdoctoral research project DAEDALUS supported by the National Research Fund, Luxembourg (FNR), grant agreement AFR-7579115, and by the Luxembourg Institute of Science and Technology (LIST). The authors would like to thank the City Council of Esch-sur-Alzette for supporting this project and collaborating with relevant discussion and data provision. Mr. Christian Braun, Luis Duque de Sousa and Alex Bertrand from LIST are kindly acknowledged for the valuable support.

#### 7 REFERENCES

1. Directive 2010/31/EU of the European Parliament and of the Council of 19 May 2010 on the energy performance of buildings (recast).
2. Tukker, A. et al., Environmental Impact of Products (EIPRO), Analysis of the life cycle environmental impacts related to the final consumption of the EU-25, in Technical Report EUR 22284 EN, 2006, European Commission, Joint Research Centre.
3. Swan, L. and Ugursal, V., Modeling of end-use energy consumption in the residential sector: A review of modeling techniques. *Renewable and Sustainable Energy Reviews*, 2009. 13, p.1819–35.
4. Kavgić, M. et al., A review of bottom-up building stock models for energy consumption in the residential sector. *Building and Environment*, 2010. 45(7), p.1683–97.

5. Österbring, M. et al., A methodology for spatial modelling of energy and resource use of buildings in urbanized areas. World Sustainable Building Conference WSB14. 2014, Barcelona, Spain.
6. Chau, C. K. et al., A review on Life Cycle Assessment, Life Cycle Energy Assessment and Life Cycle Carbon Emissions Assessment on buildings. *Applied Energy*, 2015. 143, p. 395–413.
7. Cabeza, L. F. et al., Life cycle assessment (LCA) and life cycle energy analysis (LCEA) of buildings and the building sector: A review. *Renewable Sustainable Energy Reviews*, 2014. 29, p. 394–416.
8. Lotteau, M. et al., Critical review of life cycle assessment (LCA) for the built environment at the neighborhood scale. *Building and Environment*, 2015. 93, p.165–78.
9. Heeren, N. et al., A component based bottom-up building stock model for comprehensive environmental impact assessment and target control. *Renewable and Sustainable Energy Reviews* 2013. 20, p.45–56.
10. Geyer, R. et al., Coupling GIS and LCA for biodiversity assessments of land use. *International Journal of Life Cycle Assessment*, 2010. 15 (5) p. 454–67.
11. DIN, Wärmeschutz und Energie-Einsparung in Gebäuden - Teil 4: Wärme und feuchteschutztechnische Bemessungswerte, DIN 4108-4, 2013.
12. Règlement Grand-Ducal du 26 mai 2014. Performance énergétique des bâtiments d'habitation et fonctionnels. 2014, Luxembourg.
13. Loga, T. et al., Deutsche Gebäudetypologie. Beispielhafte Maßnahmen zur Verbesserung der Energieeffizienz von typischen Wohngebäuden. 2011, Darmstadt.
14. Mastrucci, A., et al., GIS-based Life Cycle Assessment of urban building stocks retrofitting. A bottom-up framework applied to Luxembourg, in proceedings of EnviroInfo2015. 2015: Copenhagen, Denmark. p. 47-56.
15. Nemry, F., Options to reduce the environmental impacts of residential buildings in the European Union-Potential and costs. *Energy and Buildings*, 2010. 42, p. 976–84.
16. Ministère de l'Economie et du commerce extérieur, Leitfaden zur Verwendung von U-Wert-Typologien im Rahmen der Energiepasserstellung für bestehende Gebäude, v. 1.1. 2007, Luxembourg.
17. GRASS Development Team, Geographic Resources Analysis Support System (GRASS) Software. Open Source Geospatial Foundation Project. 2012. <http://grass.osgeo.org>
18. The PostgreSQL Global Development Group, PostgreSQL 9.4.0 Documentation. 1996-2014.
19. PostGIS 2.0 Manual – SVN Revision (14477) <http://postgis.net/stuff/postgis-2.0.pdf> (consulted: December 2015)
20. R Core Team, R: A language and environment for statistical computing. R Foundation for Statistical Computing. 2015, Vienna, Austria. URL <https://www.R-project.org/>
21. CEN, Sustainability of construction works – Assessment of buildings. Part 2: framework for the assessment of environmental performance, EN 15643-2, 2011.
22. CEN, Sustainability of construction works – Assessment of environmental performance of buildings – Calculation Method, EN 15978, 2011.
23. PRé Consultants and Eftting, S., Wizard Manual. Introduction into programming of Wizards in Simapro 7. 2006. <http://www.simapro.de/uploads/media/WizardManual.pdf>
24. Ecoinvent Centre. Ecoinvent version 2.2 database.<http://www.ecoinvent.org/database/ecoinvent-version-2/ecoinvent-version-2.html> (consulted: December 2015)
25. Guinée, J.B. et al., Handbook on life cycle assessment. Operational guide to the ISO standards. I: LCA in perspective. IIa: Guide. IIb: Operational annex. III: Scientific background. 2002, Dordrecht. Netherlands: Kluwer Academic Publishers.
26. De Sousa, L. et al., iGUESS – a web based system integrating urban energy planning and assessment modelling for multi-scale spatial decision making, in Proceedings International Environmental, Modelling and Software Society (iEMSs). 2012: Leipzig, Germany.





## Expanding Boundaries: Systems Thinking for the Built Environment

### GEO-DEPENDENT HEAT DEMAND MODEL OF THE SWISS BUILDING STOCK

S. Schneider<sup>1\*</sup>, J. Khoury<sup>1</sup>, B. Lachal<sup>1</sup>, P. Hollmuller<sup>1</sup>

<sup>1</sup> University of Geneva, Energy Systems, Section of Earth and Environmental Sciences  
& Institute for Environmental Sciences, Uni Carl-Vogt, CH - 1211 Genève 4

\*Corresponding author; e-mail: stefan.schneider@unige.ch

#### Abstract

One of the strategies for decarbonizing the energy mix is to increase the use of district heat networks, for distribution of waste heat or heat produced by renewable energy sources. However, planning such networks needs a geo-dependent energy database concerning demand and supply, incorporating their dependency on space and time.

The present paper concerns the development of a bottom up statistical extrapolation model for estimating the heat demand of the Swiss building stock.

The database is constructed on top of the Swiss building register, which contains basic data on building category, age, ground area and number of floors, as well as area devoted to dwellings. The model itself concerns: (i) estimation of the heated area of each building; (ii) estimation of the heat demand of each building, with disaggregation in terms of space heating (SH) and domestic hot water (DHW).

The model is calibrated by way of recorded data concerning actual yearly energy consumption of around 27'000 buildings, with a classification by building category and age. The disaggregation in terms of SH and DHW allows for climatic correction of the observed data within a common climate basis. In a second step this calibration data is used for extrapolation of the demand on the entire Swiss building stock, for which the SH component is corrected by taking into account local climate characteristics.

Finally, statistical methods tend to quantify the uncertainty inherent to the use of average demand values by age and category, in relation to the level of spatial aggregation.

#### Keywords:

Geo-dependend energy demand; domestic hot water and space heating; bottom up model; building classification

### 1 INTRODUCTION

During the year 2013, the Swiss final energy consumption for space heating of buildings and domestic hot water production is estimated to 330 (PJ/Year) by [1]. According to the national energy statistics, this represents approximately 40% of the total final energy demand. Within the Swiss Energy Strategy 2050, it is foreseen to reduce this demand by 63%, while increasing the share of renewable energy. Local renewable resources are numerous, however characterized by specific spatial availability, as well as temporal dynamics and quality (e.g. temperature), which limit their compatibility with demand. Hence, for assessing the potential of these resources and designing adequate infrastructure like district heating systems, geo-dependent energy

databases concerning demand and supply are needed. We focus here on the development of a geo-dependent heat demand model of the Swiss building stock.

Previous work in this direction was done by [2], where hectare raster statistics on dwelling surface and number of working places serves to estimate the heat demand of the Swiss building stock. However, a later model supposes that all building categories have the same specific heat demand of 120 (kWh/m<sup>2</sup> year). At European level, [3] uses population density for estimating the heat demand on a 1x1 km raster. As an alternative to such statistical extrapolation methods, other authors try to simulate the energy demand of buildings in urban area by way of models based on building physics [4, 5].

However, such an approach requires detailed information on the building's geometries as well as on the envelope components and associated U and g values. This turns out prohibitive at national level in terms of access to such data as well as in terms of computational time.

As a response to preceding questions and state of the art, this paper outlines the development of a statistical bottom up extrapolation model, which is based on measured heat demand and heated surfaces values of a representative set of about 27'000 individual buildings. As a result, and as an improvement to previous work such as [2, 6], we estimate the heat demand of each building of the Swiss national building register (GWR) as a function of its category, age and location, and its heated surface as a function of its category, gross surface and/or dwelling surface. Furthermore, a bootstrap resampling algorithm allows to quantify the uncertainty inherent to the use of average demand values by age and category, in relation to the level of spatial aggregation. This kind of approach could be applied to other countries or communities having a GIS database containing basic information of their building stock as for example the Austrian address and building register (AGWR) [7].

## 2 GEO-DEPENDENT HEAT ESTIMATION MODEL

The general structure of the model is shown in Fig. 1. The combination of basic information for each building from the GWR with average statistic indicators from the calibration sets allows to estimate the heated surface  $A_E$  ( $m^2$ ) and the specific heat demand  $E$  ( $MJ/m^2$  year), from which we derive the final energy demand  $E_B$  ( $MJ/year$ ).

For each pixel of territory, the estimated heat demand is summed over all buildings, and a bootstrap algorithm allows to estimate the confidence interval around the average value given by the model.

### 2.1 Datasets

The model uses the following datasets:

- (i) The Swiss national building register (GWR) maintained by the Swiss Federal Statistical Office [8] contains basic building information such as: geographical coordinates, category, age, ground and dwelling surface as well as the main energy carrier for around two millions of buildings. This database is not exhaustive for buildings without residential purpose. A comparison with the Swiss building footprint data layer [9] shows that around 400'000 buildings are missing. A unique federal building identification number (EGID) identifies each building, allowing to link this data with other databases.
- (ii) The Geneva SITG database contains measured energy consumption as well as heated surface  $A_E$  defined according to norm SIA 416/1, for residential buildings and buildings used for nonresidential purposes. This declaration is mandatory and is updated each year by a network of trained agents.
- (iii) The CECB database contains energy consumption averaged over three years. This is a certification covering buildings spread over the whole Swiss territory.

### 2.2 Estimation of heated surface

For each building of the GWR database, the heated surface  $A_E$  is estimated by way of the gross surface (number of floors x ground surface) and/or the dwelling surface.

The estimation is based on a set of linear regressions, on ten different building categories, given by 8'951 observations from the SITG database. As an example, we show the linear regression for the category of residential multi-family buildings (Fig. 2).

Note that the CECB database, which is anonymised, could not be linked to the gross and dwelling surface of the GWR, which is the reason why it is not used in this part of the process.

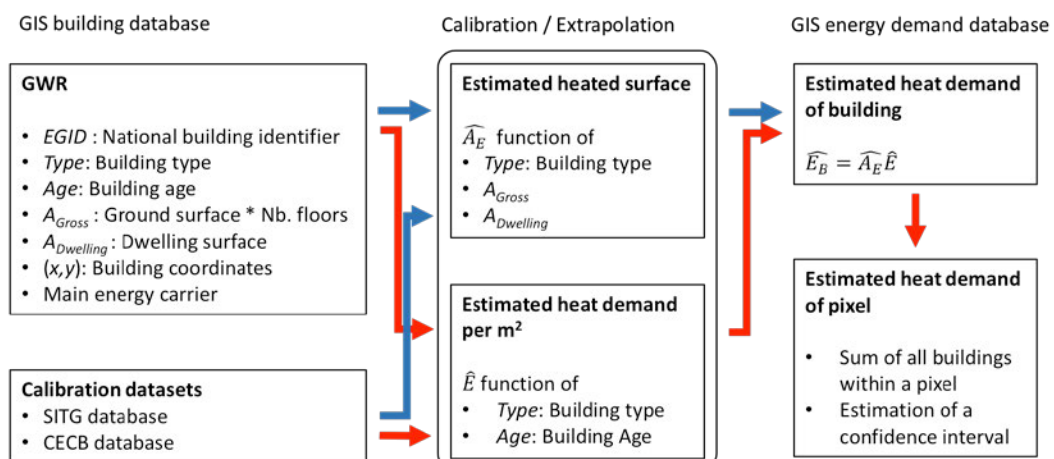

Fig. 1: Model overview.

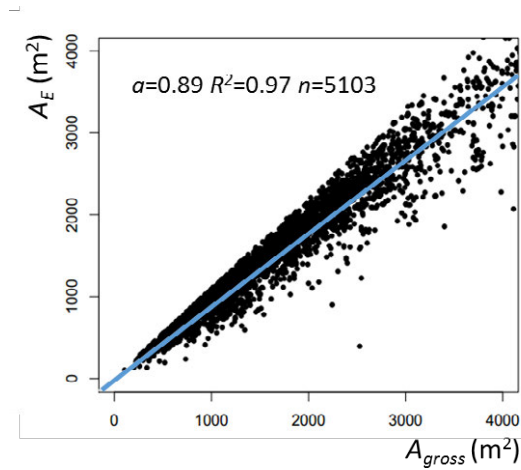

Fig. 2:  $A_E$  as a function of gross surface (multifamily buildings).

### 2.3 Estimation of specific heat demand

For each building of the GWR database, the specific final energy for heat demand  $E_B$  is estimated by way of its age and category, on hand of average values given by the SITG and CECB datasets, which are normalized to a common reference.

#### Normalization of calibration data to a common reference

Since heat demand data of CECB and SITG concern a variety of energy carriers and locations, it has first to be normalized to a common reference. Therefore, for each building of these datasets, the measured final energy demand  $E$  (MJ/m<sup>2</sup> year) is converted into useful heat demand for space heating:

$$Q_{SH} = \eta_{EC} E - Q_{DHW} \quad (1)$$

$\eta_{EC}$  is the transformation efficiency factor estimated by [10] and  $Q_{DHW}$  the useful heat demand for DHW production according to the SIA 380/1 norm. Since some very low energy buildings may have thermal solar panels, leading to very low  $Q_{SH}$  values, we further add following constraint:

$$Q_{DHW} = \min(Q_{DHW}^{SIA}, 2/3 \eta_{EC} E) \quad (2)$$

The space heating values are further normalized to a common climatic reference (arbitrarily Geneva):

$$Q_{SH}^{GE} := Q_{SH} \frac{DJ(GE)}{DJ(Origin\ of\ measure)} \quad (3)$$

$DJ$  (*Origin of measure*) stands for the norm SIA 2028 heating degree days from the climatic station associated to the building.

Finally, the SITG and CECB data sets allow computing 15'588 and 11'499  $Q_{SH}^{GE}$  values normalized to Geneva's climatic reference.

### Statistical analysis by building category and age

For the sake of statistical analysis, preceding data is grouped in four building categories (multifamily residential, individual residential, nonresidential, mixed purposes). For each of these categories, the data is further divided into 12 construction periods, and analysed in terms of statistical distribution (Fig. 3). At this stage, it is worthwhile noting that the variability within each construction period is much higher than between the periods, as previously put forward by [10].

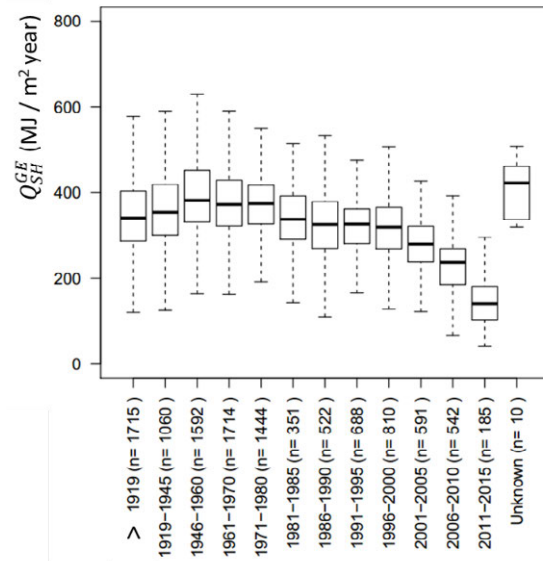

Fig. 3: Boxplot distribution of  $Q_{SH}^{GE}$  by construction period (multifamily buildings, SITG database).

Finally, for each of the building categories and construction periods, we define the average space heating demand which is used for extrapolation on the GWR database:

$$\overline{Q_{SH}^{GE}} := \frac{\sum_{i} Q_{SH}^{GE} A_E}{\sum_{i} A_E} \quad (4)$$

This analysis is done separately for the SITG and CECB datasets, the respective values being used for reconstruction of the entire GWR building stock located in Geneva, respectively in the rest of the Swiss territory.

### 2.4 Heat demand at building and pixel level

For each building of the GWR database, the specific heat demand is estimated by the average demand of its corresponding category and construction period with

$$\hat{E} = 1/\eta_{Agent} \left( \overline{Q_{SH}^{GE}} \frac{DJ(b)}{DJ(GE)} + Q_{DHW} \right) \quad (5)$$

On this basis, we compute the sum of the heat demand of all buildings contained in a pixel of territory:

$$\hat{E}_{Pixel} = \sum_{B \in Pixel} \hat{E}_B = \sum_{B \in Pixel} \hat{A}_E \hat{E} \quad (6)$$

The procedure is repeated on the entire Swiss territory, on square pixels of scalable sizes, ranging from 100 (m) to 1.6 (km).

### 2.5 Confidence intervals

For each of the above pixels, we compute a confidence interval around the estimated heat demand value. It is computed by way of a bootstrap resampling algorithm [11], which consists in generating a heat demand distribution, which replicates the dispersion of the calibration datasets.

Therefore, for each building of the pixel, a new  $\hat{E}$  value is generated by replacing the  $\overline{Q_{SH}^{GE}}$  value of (5) by a randomly picked value of the corresponding calibration dataset (same building category and construction period). Similarly, the heated surface  $\hat{A}_E$  is replaced by

$$\hat{A}_E^* := (1 + \Delta\hat{A}_E)\hat{A}_E \quad (7)$$

where  $\Delta\hat{A}_E$  is a randomly picked relative error of the corresponding linear regression model, defined as:

$$\Delta\hat{A}_E := \frac{A_E - \hat{A}_E}{\hat{A}_E} \quad (8)$$

The replicated  $\hat{E}$  and  $\hat{A}_E$  values are fed into (6), generating a replicated heat demand of the entire pixel. Repeating this procedure a 1000 times per pixel generates the heat demand distribution of each pixel. Finally, the limits of the 10% level confidence interval are the 5% and 95% percentiles of this distribution.

### 2.6 Results

#### At national level

Around 90% of the 1.93 million buildings listed in the GWR have sufficient data for applying the appropriate regression model. Summing up all  $\hat{A}_E$  values leads to a total heated surface estimation of 706.2 million m<sup>2</sup>. The total aggregated final energy demand is 340 (PJ/Year) for a reference climatic year.

#### At pixel level

The results of the model, which cover the entire Swiss territory, are made available by way of a dedicated web service [12].

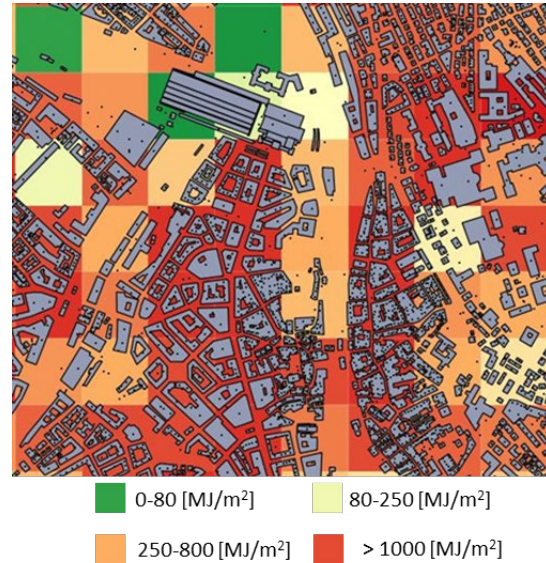

Fig. 4: Sample map of a district of Zurich.

We finally build heat demand GIS maps, with more or less aggregated information, depending on the zoom level. Fig. 4 shows an example of such a heat density map for an urban district. A colour ramp indicates the final energy consumption per square meter of territory, for each pixel of 200 (m) size.

## 3 DISCUSSION

### Model variables

In this model, the variables used for determination of the specific heat demand have been limited to building category and age. In principle, the model could be refined with the use of additional factors, like building size or floor area ratio, which could be estimated on hand of the data contained in the GWR. However: (i) a rapid analysis of the SITG calibration dataset shows that, although statistically significant, these factors remain of secondary order; (ii) further subdivision of the calibration datasets would lead to statistically small subsets and related representativeness issues.

Due to similar representativeness issues within the calibration datasets, following finer categorizations were also abandoned (but could be introduced once more calibration data is available): (i) subdivision of the buildings in a larger number of categories, in particular for the nonresidential sector; (ii) categorization of the heat demand by Canton, for tracking and taking into account the local specificities (other than the degree day issue, which is included in the model). As seen in section 2.3, and due to the high level of information of the SITG database, Geneva is the only exception to this uniform territorial categorization.

### Comparison with national statistics

The total heated surface estimation is 6% below the estimation of 754 million m<sup>2</sup> given by [1]. The fact that the GWR is not complete for industrial and services buildings can explain part of this gap. When focusing on the residential sector, the model yields 580 million m<sup>2</sup>, against 509 million m<sup>2</sup> in [1].

The total aggregated final energy is in line with national demand statistics as [1]. This good concordance speaks in favour of the quality of the model, which was not calibrated for this purpose.

### Confidence intervals

A strong added value of the model is the generation of a confidence interval around the estimated heat demand of each pixel. Due to the high dispersion of the specific heat demand within each building category and age class (Fig. 3), the confidence interval can turn out quite large for pixels containing only few buildings, and reduces when more buildings are aggregated (the averaging of the dispersion effect). A forthcoming paper will expose the relationship between aggregation level and estimation uncertainty in more details. The main outcome is that the uncertainty decreases proportionally to  $1/\sqrt{Nb. \text{ buildings}}$  as predicted by the central limit theorem.

## 4 CONCLUSION

The strength of this bottom up model is to allow the estimation of geo-dependent heat demand at any aggregation level for the Swiss territory. The estimation of consumption based on the distribution of measured consumptions bears the advantage of including the variability between buildings of the same category and age. As a result, a bootstrap resampling algorithm allows to quantify the precision of the aggregated heat demand, which is an added value compared to previous approaches. Finally, the good concordance of the total aggregated final energy demand with national demand statistics speaks in favour of the quality of the model.

## 5 ACKNOWLEDGMENTS

This research is being financed by CTI within the SCCER FEEB&D (KTI.2014.0119) project. The authors thank the Swiss Federal Statistical Office, for free access to the GWR database. We also thank Professor Martin Kumar Patel of the University of Geneva for giving us access to the CECB database (exchange of information within the scope of a collaboration with SCCER CREST).

## 6 REFERENCES

1. Kemmler, A., et al., Analyse des schweizerischen Energieverbrauchs 2000 - 2013 nach Verwendungszwecken (2014), in BFE Report. 2014, Bundesamt für Energie: Bern.
2. Eicher and Pauli AG, Ausbau von WKK in der Schweiz WKK-Standortevaluation auf Basis einer GIS-Analyse (2011), in Verband Effiziente Energie Erzeugung Final report. 2011, Dr. Eicher+Pauli AG: Liestal.
3. Connolly, D., et al., Heat Roadmap Europe: Combining district heating with heat savings to decarbonise the EU energy system. Energy Policy, 2014. 65(0): p. 475–489.
4. Perez, D., A framework to model and simulate the disaggregated energy flows supplying buildings in urban area (2014), in PhD thesis Report No 6102. 2014, EPFL: Lausanne.
5. Perez, D., et al., CitySim simulation: the case study of Alt-Wiedikon, a neighbourhood of Zürich City, in CISBAT 2011 - CleanTech for Sustainable Buildings. 2011: Lausanne, Switzerland. p. 937–940.
6. Eicher and Pauli AG, Weissbuch Fernwärme Schweiz – VFS Strategie, Langfristperspektiven für erneuerbare und energieeffiziente Nah- und Fernwärme in der Schweiz (2014), in Final report phase 2. 2014, Dr. Eicher+Pauli AG: Liestal.
7. The Austrian address and building register (AGWR). Information available online at: [http://www.statistik.at/web\\_de/services/adress\\_gwr\\_online/index.html](http://www.statistik.at/web_de/services/adress_gwr_online/index.html). Accessed: 12-April-2016.
8. OFS, Registre fédéral des bâtiments et des logements: Catalogue des caractères (2012), in user manual 2012, Office fédéral de la statistique (OFS): Bern.
9. Swisstopo, Swisstopo Topographic Landscape Model TLM (2015). Available online at: <http://www.swisstopo.admin.ch/internet/swisstopo/en/home/topics/geodata/TLM.html>. Accessed: 25-Feb-2015.
10. Khoury, J., Rénovation énergétique des bâtiments résidentiels collectifs: état des lieux, retours d'expérience et potentiels du pargenevois (2014), in PhD thesis Report No 4752. 2014, University of Geneva.
11. Efron, B. and R. Tibshirani, An introduction to the bootstrap. 1993, New York: Chapman & Hall.
12. Schneider, S., et al., SCCER FEEB&D Geo-dependent energy supply and demand web service. <http://wisescer1.unige.ch/>. Accessed: 12-April-2016.





## Expanding Boundaries: Systems Thinking for the Built Environment

### ECONOMIC AND ECOLOGICAL ASSESSMENT OF CUBAN HOUSING SOLUTIONS USING ALTERNATIVE CEMENT

Y. Cancio<sup>1\*</sup>, S. Sanchez<sup>1</sup>, F. Martirena<sup>1</sup>, I.R. Sanchez<sup>1</sup>, K. Scrivener<sup>2</sup>, G. Habert<sup>3</sup>

Universidad Central de Las Villas, Carretera a Camajuani Km. 5 ½, Santa Clara, Villa Clara, Cuba

<sup>2</sup>Laboratory of Construction Materials, Swiss Federal Institute of Technology Lausanne, EPFL, STI-IMX-LMC MXG 211 (Bâtiment MXG) Station 12 CH-1015 Lausanne, Switzerland

<sup>3</sup>Chair of Sustainable Construction, Swiss Federal Institute of Technology ETH Zürich, IBI, HIL F 27.3, Stefano-Francini Platz 5, 8093, Switzerland

\*Corresponding author; e-mail: yudieskycd@uclv.edu.cu

#### Abstract

Concrete is the most manmade material solution produced and used worldwide. Its cornerstone is the cement composite due to the high emissions level and resources consumption volume. Roughly 5-7% of global carbon dioxide emissions come from cement manufacture process. The far-reaching alternative of replacing a clinker portion in the cement material composition has gained consensus. It becomes relevant in emerging economies since in the short term there are no widely available ways for increasing the production capacity while diminish the environmental impact with no additional investment cost. Low carbon cement (LC<sup>3</sup>) is leading the contemporary path towards facing environmental challenges and resource scarcity. This article aims to assess the theoretical consideration of replacing the Cuban traditional cements with LC<sup>3</sup> according to housing case studies in Villa Clara province. On the basis of LCA background and the supply chain rationale, a procedure for discussing a sustainable contribution of LC<sup>3</sup> is designed and applied. Hollow blocks and mortars have been included in the calculations as well as the manufacturing/transportation processes for the entire supply chain of one semidetached two storey row houses built in the core of a slum-like settlement at Condado Suburb-Santa Clara city. This approach demonstrates that the LC<sup>3</sup> incorporation in the Cuban construction sector could afford considerable economic savings with the subsequent contribution in favour of the environment.

#### Keywords:

Low carbon cement; LCA; sustainability; eco-efficiency

#### 1 INTRODUCTION

One of the most acute concerns of the current century is the survival of mankind. Global carbon dioxide (CO<sub>2</sub>) emissions from fossil fuel combustion and from industrial processes (cement and metal production) increased in 2013 to a new record of 35.3 billion tonnes (Gt) CO<sub>2</sub>, which is 0.7 Gt higher than last year's record [1]. Cement production accounts for roughly 5-7% of this environmental damage. So far, cementitious materials are not replaceable when building up infrastructure since concrete is a composite that requires a binder reacting with water to further harden. Cement production and consumption is meant to be trending upward in developing countries in forthcoming decades. This is the case in Cuba, where the demand for cement has been forecasted to have a growth rate of 18% (short

term), 10% (middle term) and 5% (long term). The clinker is the active ingredient of cement and its production process is quite energy intensive. That is why cement manufacture is not only a matter of pollution, but also a matter of the economy. Ordinary Portland Cement (OPC), with at least 88% of clinker, becomes a very pricey good. Bearing these two sustainability dimensions in mind (Economy and Ecology), the use of a potential surrogate for clinker in the cement content has been deeply studied and well-documented. Funded by the Swiss Agency for Development and Cooperation, a joint project with participation of Swiss, Cuban and Indian scientists has developed a new type of cement, named Limestone Calcined Clay Cement (LC<sup>3</sup>). LC<sup>3</sup>, a low carbon cement, which is a blended cement containing 30% of metakaolin (calcined kaolinite

clay), has been produced in Cuba in an industrial trial form 2013 and 2015. This paper aims to present the economic and ecological impact of this alternative cement when used in Cuban housing projects in the province of Villa Clara.

## 2 METHODOLOGY AND DATA COLLECTION

### 2.1 Defining the assessment protocol

In order to assess the economic and environmental contribution of LC3 in housing applications in Cuba, the following 5-phase procedure is proposed and later applied.

- (i) Definition of goals and scope
- (ii) Supply chain characterization and mapping
- (iii) Creation of Data inventory
- (iv) Setting eco-efficiency indicators and calculations
- (v) Reporting eco-efficiency profile and interpretation

Phase (i) is intended to clarify the construction type and all technical features associated with the construction system to be assessed. Functional unit (F.U.) and system boundaries (S.B.) should be defined as well. Limitations or assumptions derived from F.U. and S.B. are adopted in this Phase. Alternatives, strategies or scenarios are also described if necessary (especially when comparing different technologies).

Phase (ii) characterizes all flows downstream from the target building, identifying key players over the whole supply chain and their roles on the construction system under analysis. A diagram for mapping the supply chain is recommended so that a holistic understanding could be possible by inspecting the drawing.

In Phase (iii) all required data is collected following the flow route described in Phase (ii). Background and foreground data should be clearly organized in order to further be combined into eco-indicators. All material flows generate physical quantities and monetary quantities throughout the supply chain. Building materials are needed to be traced from quarries to building (construction site), determining economic and environmental inflows and outflows (inputs and outputs).

Phase (iv) integrates all material and economic flows along the chain, yielding an overall measure for both economic and ecologic performance of the alternatives confronted. Afterwards, for interpretation purposes it is recommended to combine both dimensions by means of an eco-efficiency indicator. According to the WBCSD [2] an eco-efficiency indicator is the ratio that relates an economic performance measure to an environmental load. Damini et al. (2010) [3] proposed two basic eco-efficiency indicators in order to measure and assess the cement use, namely *binder intensity* (bi) and *CO<sub>2</sub> intensity* (ci). However, these indicators are more applicable to

concrete mix design assessment, when a large number of observations or samples is taken into account. For the case of the functional unit targeted in this paper, a conventional eco-efficiency indicator proposed by WBCSD is employed, relating revenues (at the level of 1 m<sup>2</sup> of wall) and carbon dioxide emissions.

Phase (v) is intended to draw up conclusions as from the findings achieved in Phase (iv), setting up the eco-efficiency profile of each option evaluated. This procedure takes theoretical background from Life Cycle Assessment based on ISO 14040 (2006) [4] and the Eco-efficiency procedure has been standardised by ISO 14045 (2012) [5].

### 2.2 Data collection

The primary variables included in the database (foreground data) are cement, sand, gravel, calcium hydrate, crushed stone, water and hollow blocks. Data comes from the housing project design and was contrasted with the construction company as well. The concrete blocks data was taken from Vizcaino-Andres (2014, 2015) [6], [7], based on industrial blocks manufacture (for OPC-made blocks) and LC<sup>3</sup> blocks have been produced at local level in an *eco-materials workshop* at Manicaragua (Villa Clara). Economic and environmental inputs for cement are taken from Sanchez (2015) [8], who has assessed in-depth the cement cost and the environmental effects for different types of cement produced in Cuba, especially compared to LC<sup>3</sup> production. Transportation fuel consumption was obtained from the Enterprise for Construction Materials Transportation at provincial level. Fuel consumption per kg of material for different types of aggregates was obtained from Building Materials Trading Company at regional level. Electricity consumption per unit material was also gathered from the referred enterprises. In respect to background data, environmental calculations have assumed an emission factor of 3.21 kg CO<sub>2</sub> per kg of diesel, according to the annual report of National Enterprise for Fuel Trading (CUPET), titled *Fuel Quality Specifications*. Diesel density of 0.8379 kg/L is used for needed conversions, as disclosed in the above mentioned report. Electricity emission factor is assumed to be 7.44x10<sup>-4</sup> kg CO<sub>2</sub> per kWh, according to a similar report from Cuban Electric Power Union. Standard unit material consumptions (material intensity) were found in Perez (2013) [9], and served as documented reference while comparing material consumption that originated from construction enterprises. Both data sources are coincidental.

## 3 RESULTS

### 3.1 Definition of goals and scope

After the first industrial trial of LC3 cement in Cuba, a subsequent use of this cement took place in the construction sector. The local government



supported the construction of one semidetached two storey row houses in the core of a slum-like settlement at Condado suburb-Santa Clara city. All masonry mortars consumed in the second floor employed LC3, which encompasses placing blocks, plastering, patching walls and all finishing activities.

#### Definition of scenarios

In this case study, LC3 was used in masonry activities; nevertheless, the blocks used in the whole construction were produced with cement P-35 (the Cuban equivalent of OPC). That is why three scenarios were devised in order to undertake the eco-efficiency assessment, which is described as follows:

Scenario 1: Traditional cement-Scenario, which means that blocks are made of P-35 and mortars are made of PP-25 (the Cuban equivalent of PPC), both are traditional cements in Cuba.

Scenario 2: Combined P-35/LC3 Scenario, in which blocks are made of OPC and mortars of LC3 (this is the real scenario of house built at Condado-SC).

Scenario 3: Entire LC3 Scenario, which supposes that both blocks and mortars are made of LC3.

Ecological and economic implications of LC3 use, in this case study, is assessed based on one squared meter of wall as a functional unit. As the cement sustainability assessment taken from [6], [7] and [8] starts in quarrying activities (cradle-to-gate approach), the present study covers the material cycle from quarrying up to the use phase. It ends up at the construction level and does not take into account neither the recycling of materials nor the operational emissions derived from the use phase of building.

### 3.2 Supply Chain characterization and mapping

Fig.1 shows the supply chain (S.CH.) from materials' procurement up to the construction site. As shown in this diagram, 12 enterprises were involved in the housing construction throughout the supply chain. Among them, 9 are producers and suppliers of raw materials (building materials), two are intermediary companies whose main function is merely a commercial entity and one is a construction company. Dashed lines indicate the links between nodes or enterprises along the supply chain, and the arrows' direction indicates the material flows throughout the S.CH. Conversely, the economic flows are traced back from the end to the starting point in the sense that each enterprise pays for the goods supplied by the preceding entity. The links are deeply important because through the economic relationship between firms the value added has been created from quarrying to the final building and, in the same principle, the environmental flows are considered as a cumulative amount.

### 3.3 Creation of Data inventory

Table 1 shows the unit material consumption used in one square meter of wall, which becomes the base for an economic and environmental assessment, therefore, for eco-efficiency indicators.

Materials consumed	Cement (kg)	Sand (m <sup>3</sup> )	Gravel (m <sup>3</sup> )	Crushed stone powder (m <sup>3</sup> )	Calcium hydroxide (kg)
Blocks/materials consumed	22.36	0.052	0.078	0.013	
Mortar/Blocks placement	6.25	0.018			3.6
Mortar/Finishing	5.27	0.038			2.85
<b>Total</b>	<b>33.88</b>	<b>0.108</b>	<b>0.078</b>	<b>0.013</b>	<b>6.45</b>

Table 1: Consumption material 1 m<sup>2</sup> of wall.

It is presented separately according to the kind of masonry activity; the materials involved in the production of 13 hollow concrete blocks – those required to build up one m<sup>2</sup> of wall – are reported in the first row. Economic cost and CO<sub>2</sub> emitted were calculated on the base of material consumption stated in Table 1. CO<sub>2</sub> released due to transportation was calculated based on the amounts of material specified. Table 2 presents the fuel consumption and electricity consumption scaled to the level of 1 m<sup>2</sup> of wall. Table 3 shows the fuel consumption per kilometre according to the building material shipped.

Building material (excluding cement)	Diesel (L)	Electricity (KWh)
Blocks (U)	0.312	0.481
Sand (m3)	0.0684	0.204
Ca(OH) <sub>2</sub> (kg)	0.0438	0.045
<b>Total</b>	<b>0.4242</b>	<b>0.73</b>

Table 2: Diesel and electricity consumed in material obtaining (1 m<sup>2</sup> of wall).

Building material	Consumption index (L/km)	Load capacity	Unit	Distance (km)
Cement	0.4504	20000	kg	188
Sand	0.4	10000	kg	96
Ca(OH) <sub>2</sub>	0.4	10000	kg	188
Block	0.3086	1290	U	110
Water	0.2222	6000	L	20

Table 3: Fuel consumption (shipping).

Load capacity is later used to derive an impact index due to transport activities. In this study, the environmental assessment covers the carbon dioxide emissions generated largely due to the embodied energy into all materials consumed in one square meter of wall, resulting from its previous production process in itself.

Input data is taken from two different sources. Cement emissions have been taken from previous research results shown in [6], [7] and [8], who have extensively examined the Cuban cement industry and its related cement types. The remaining building materials CO<sub>2</sub> related emissions, i.e.

sand, gravel, crushed stone powder, calcium hydroxide, have been derived as a direct result of the present study. Emissions due to transportation of all building materials have been estimated in this study.

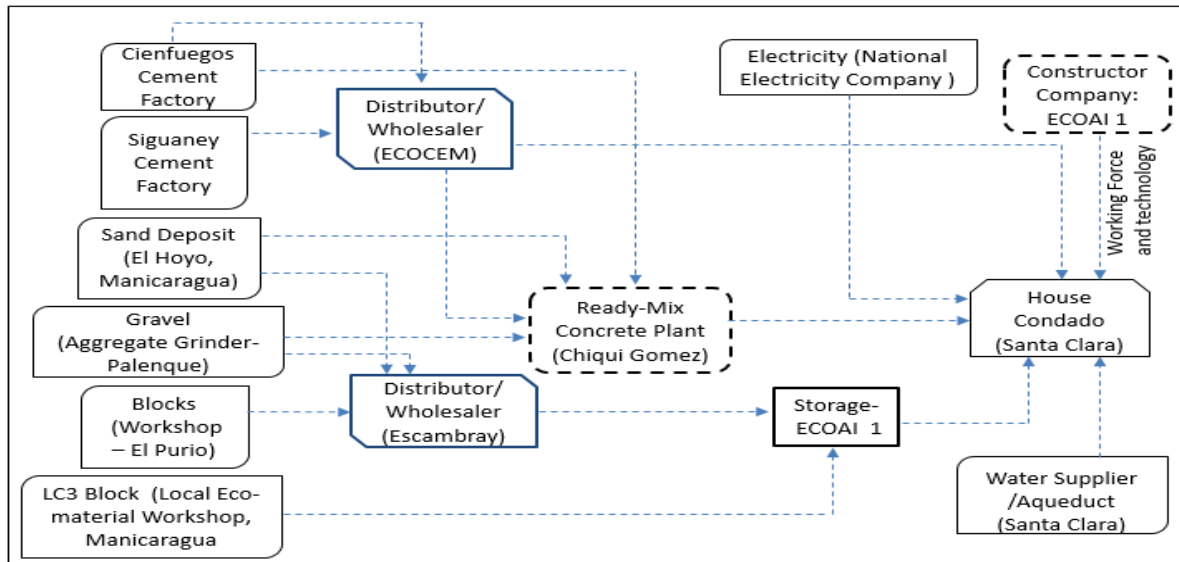

Fig. 1: Supply chain mapping for housing case study.

### 3.4 Setting eco-efficiency indicators and calculations

Table 4 summarizes the CO<sub>2</sub> emitted during obtaining the building materials involved in 1 m<sup>2</sup> of wall as well as the emissions derived from transporting all materials from suppliers to construction site. In this report, an allocation method is proposed, ensuring distribution of all CO<sub>2</sub> released during the transportation process amongst different units of material shipped. For simplification reasons, the means of transportation is not declared in table 3, although, conventional trucks, which are representative in Cuban construction sector, have been considered. The framework of table 3 lets us to apportion the fuel consumption among the truck carrying capacity (e.g. 20 000 kg of cement) by means of a conversion coefficient. Furthermore, a generic scalar value is attained when dividing consumption index (L/km) by the carrying capacity. The resulting number indicates the share of fuel consumption that corresponds to each unit quantity of material shipped (i.e., L/km/U). Afterwards, this conversion index is multiplied by the transportation distance and later by the amount of material used in real construction. This is the prior calculation needed before reckoning the CO<sub>2</sub> released due to transportation. Diesel engines release ~2.6 kg CO<sub>2</sub> per L of diesel fuel burned [10]. This reference figure was used while determining environmental loads associated with transportation.

Table 4 summarizes the environmental load of each scenario, by adding CO<sub>2</sub> emissions due to fabrication process to those released during

shipping raw materials. The cement manufacturing impact is also summed as it appears in the first row.

Pollutant Source	Sc. 1	Sc. 2	Sc. 3
Cement production	32.87	30.48	22.77
Obtaining aggregates and blocks*	1.14	1.14	1.14
Transportation	1.44	1.44	1.44
<b>Total</b>	<b>35.45</b>	<b>33.07</b>	<b>25.35</b>

\*Cement consumed in block production is counted in first row (Sc: scenario)

Table 4: CO<sub>2</sub> emissions by pollutant source.

Table 5 presents the eco-efficiency upshot, according to the ratio explained in section 2.

Item	Sc. 1	Sc. 2	Sc. 3	Δ (%)
Revenues	6.96	6.85	6.29	2 vs. 3 20
Emissions	35.45	33.07	25.35	1 vs. 2 5
Eco-indicator	0.20	0.21	0.25	1 vs. 3 26

Table 5: Eco-efficiency indicator over scenarios.

### 3.5 Reporting eco-efficiency profile and interpretation

It is clearly noticeable that ~92% of overall emissions embedded in 1 m<sup>2</sup> of wall belongs to cement, as expected (Table 4). That is why its negative impact on the environment is a global concern, therefore, it encourages this kind of research. Aggregates and blocks represent altogether the remaining 8% (roughly 4.5% each). By only switching from cement P-35 to LC3 in mortar, emission savings account for 7% (scenario 1 vs. 2). This is the real environmental

advantage of House-Condado-Santa Clara, which employed the technology depicted in scenario 2. Moving from scenario 2 to 3, which in addition means producing LC3 blocks, savings of ~30% might be achieved. This is merely the effect of introducing LC3 in block production plants. A full replacement of traditional cements currently being used in the construction sector in Cuba (P-35 for blocks and PP-25 for mortars) leads to a 40% carbon dioxide emission savings. In terms of economic cost, replacing traditional existing cements by LC3 lessens the production cost by ~11%. Looking at the joint effect (economy-environment), LC3 mortars could increase the eco-efficiency of cement use by 5%; moreover, producing LC3 blocks would raise the eco-indicator by 20%.

The combination of both (mortars and blocks made of LC3) would raise the sustainability of buildings by roughly 26%. It is difficult to mention a consideration around performance of 1 m<sup>2</sup> of wall, since all materials are combined in a structure. Structures like walls, floors roofing decks are built to last and provide comfort to dwellers. Nevertheless, once all building materials are embedded into a structure, properties like durability and comfort are difficult to foresee, to a large extent. It should be revisited and still is a challenge.

#### 4 DISCUSSION

The results emerging from eco-efficiency analysis can be read as follows: 0.20 US\$ of revenue per kg of CO<sub>2</sub> emitted is achieved in each square meter of wall when using conventional cements. When introducing LC3 in mortars, at the same level of functional unit, 0.21 US\$ of revenue per kg of CO<sub>2</sub> would be reached. The full LC3 scenario elicits 0.25 US\$ of revenue per kg of CO<sub>2</sub>, which represents a straightforward advantage in terms of economic and environmental impact. Taking into account a 28-day compressive strength of 4.47 MPa for LC3 hollow blocks and 5.3% absorption [6], the replacement of traditional cements in blocks manufacture would be feasible from a technical, economic and environmental viewpoint. Compressive strength in LC3 mortars are in the order of 8.98 MPa and absorption by capillarity 7-days is ranking like PPC mortars (1.58 g/cm<sup>2</sup>) (Alvarez, 2014) [10]. Additional goodness of LC3 mortars can be found in [10], like medium adherence, open porosity.

The social dimension of sustainability is understood as from the odds to use less costly building materials like LC3, which in turn allows to produce a wide range of related construction materials using the same low clinker binder. This implies a better purchase power for end consumers at existing markets.

#### 5 CONCLUSIONS

The methodology proposed and applied in this case study is proven to be feasible and easy to handle if the purpose lies in the sustainability concept, which encompasses economic, environmental and social dimensions. The scenarios evaluated show the marginal effect of replacing traditional cements in mortars and blocks while building one square meter of wall. LC3 performs in a very costeffective way and environmentally friendly, it is ~26% more sustainable than conventional cements. Potential costefficiency and CO<sub>2</sub> savings would be induced if the analysis is scaled to the level of entire houses. The supply chain approach is deeply aligned with LCA methodology. Combining both provides researchers with a comprehensive framework in understanding the links between economic and environmental flows when tracing the route of building materials. The findings presented in this paper shed light on policymakers in the Cuban cement industry and governmental key players on the potential core decisions concerning construction sector investments.

#### 6 ACKNOWLEDGEMENTS

Authors want to thank the valuable support by the Construction Enterprise committed with the social housing Condado-Santa Clara (ECOAI 1), the Cement Factory Siguany for the successful industrial trial of LC3 and the Local Building Materials Workshop at Manicaragua, where LC3 blocks were produced.

#### 7 REFERENCES

- Olivier, J., et al., Trends in global CO<sub>2</sub> emissions: 2014 Report, in PBL Netherlands Environmental Assessment Agency. Joint Research Center European Commission, [http://edgar.jrc.ec.europa.eu/news\\_docs/jrc-2014-trends-in-global-co2-emissions-2014-report-93171.pdf](http://edgar.jrc.ec.europa.eu/news_docs/jrc-2014-trends-in-global-co2-emissions-2014-report-93171.pdf)
- Verfaillie, H. and R. Bidwell, Measuring Eco-efficiency. A guide to reporting company performance, in World Business Council For Sustainable Development Report. [http://www.wbcsd.org/web/publications/measuring\\_eco\\_efficiency.pdf](http://www.wbcsd.org/web/publications/measuring_eco_efficiency.pdf)
- Damineli, B., et al., Measuring the eco-efficiency of cement use. Cement & Concrete Composites, 32 (2010): p. 555-562
- ISO 14040 (2006): Environmental Management, Life Cycle Assessment, Principles and framework. [http://www.iso.org/iso/home/store/catalogue\\_ics/catalogue\\_detail\\_ics.htm?csnumber=37456](http://www.iso.org/iso/home/store/catalogue_ics/catalogue_detail_ics.htm?csnumber=37456)
- ISO 14045 (2012): Environmental Management, Eco-efficiency Assessment of product systems, Principles, requirements and guidelines. [http://www.iso.org/iso/catalogue\\_detail?csnumber=43262](http://www.iso.org/iso/catalogue_detail?csnumber=43262)
- Vizcaino-Andres, L., Cemento de bajo carbono a partir del sistema cementicio ternario clinquer-arcilla

calcinada-caliza. 2014, Doctoral Dissertation Report. UCLV-Library.

7. Vizcaino-Andres., et al., Industrial trial to produce a low clinker, low carbon cement, in *Materiales de Construcción*, Vol. 65, Issue 31, January-March 2015.

<http://materconstrucc.revistas.csic.es/index.php/materconstrucc/article/viewFile/1681/2044>

8. Sanchez, S., Economic and environmental impacts of LC3. Specific case of Cuba. PPT Presentation in LC3 International Meeting. Zürich, Switzerland. May, 2015.

9. Perez, Y. Evaluación de la eco-eficiencia en la cadena productiva de una vivienda construida con cemento de bajo carbono, 2013, Tesis de Licenciatura en Economía. UCLV-Library.

10. Valsecchi, C., et al., Environmentally harmful subsidies: identification and assessment, Final Report, 2009, Institute for European Environmental Policy (IEEP).

11. Alvarez, C., Evaluación de las propiedades de los morteros de albañilería elaborados con cemento de bajo carbono, 2014, Tesis de Ingeniería Civil, UCLV-Library.



## Expanding Boundaries: Systems Thinking for the Built Environment

### A SUSTAINABLE DEVELOPMENT APPROACH FOR AFFORDABLE HOUSING IN EGYPT

A. Mokhtar<sup>1\*</sup>

<sup>1</sup> American University of Sharjah, PO Box 26666, Sharjah, United Arab Emirates

\*Corresponding author; e-mail: mokhtar@aus.edu

#### Abstract

Egypt suffers from a severe shortage in affordable housing. The government's main approach to the problem is to subsidize the affordable housing developments. As the available financial resources are very limited, this approach cannot cope with the size of a growing problem. Recently, the government announced that hundreds of thousands of units are planned. Yet, these – when built - will hardly cover the new demands leaving untouched the accumulated deficits of past decades. This paper propagates a new approach to address the problem. The approach aims to provide sustained developments of affordable housing units without the need for government subsidies. This is to be achieved by making the development of these units a profitable investment for the private sector. The approach is based on viewing the developments of affordable housing units as a development of a community with a variety of needs. These needs create values that allow businesses to make profit. The approach is supported by two supplementary ideas. The first is a decentralized green infrastructure for the development. The second is to make use of the Egyptian culture in term of social responsibility. The paper explains the approach and its supplementary ideas. It also shows the results of a financial study that proves the feasibility of this approach.

#### Keywords:

Affordable housing; Low-income housing; Real estate finance, Real estate development

## 1 INTRODUCTION

In its last official consensus, data shows that Egypt had about 953,140 official marriage contracts [1]. In a country where getting married signals the time to live in a separate housing unit, this figure can be a guide to the number of new housing units needed in the country. Considering that some couples use existing housing stock, government officials estimate that the demand for new housing is between 300,000 to 400,000 units annually<sup>1</sup>. However, both the public and the private sectors together officially build about 160,000 units annually on average between 2004 and 2014 [1]. These numbers clearly demonstrate the annual and accumulated deficit

in new housing units and hence the severe shortage in housing units in Egypt. With about 6 million couples who are in the marriage age but not married and a population structure where more than 50% of the population are less than 20 years old [1], the demand for new housing units will continue to increase significantly in Egypt. This is particularly the case for the affordable housing sector of the market where it is much more difficult to accommodate its need due to the cost versus affordability factor.

While the housing shortage problem has many contributing factors (e.g. low-cost design and availability of land), the financial factor - represented in the approach to develop the housing project - is the core of the problem. The traditional approach for developing affordable housing projects requires financial contribution by the government in the form of subsidies. With

<sup>1</sup> Data provided through an interview with Eng. Galal Sayed Al-Ahl, Chair of the Executive Council for the National Housing Project, Ministry of Housing and Development, Egypt, July 2010.

Egypt's very tight budget, this approach hardly addresses the problem.

The government recovers part of these subsidies from selling primary land to luxury developments. This approach leaves the affordable housing units in locations that are far away from the residents' income generation locations that are typically in - or close to -populated urban areas. It also results in raising land prices for middle class buyers as the government auctions the primary land for the luxury developments. This leads to an increase in the portion of people who cannot afford a housing unit.

The aim of this paper is to report on the viability of using another approach suggested by the author to address the problem. The approach aims to ensure sustainable development of affordable housing units without government subsidies. The approach is supported by two supplementary ideas. The paper starts by an explanation of the approach and the ideas. It then reports on the results of a financial study - for an assumed development - that is based on the proposed approach. The paper then shows an analysis of these results to determine the feasibility of using the new approach.

## 2 NEW APPROACH

The large demand for affordable housing in Egypt represents a sizable market that is barely tapped at the moment by the large private sector developers. If those developers can make a reasonable profit in this sizable market without being restricted to the availability of government subsidies, they would use their financial capabilities and their technical expertise to continuously develop affordable housing projects. Such sustained effort will ultimately solve the problem as more and more developers will tap into this market to make profit.

Clearly, the challenge is how to make it profitable to develop affordable housing projects. The fact remains that - in Egypt - the cost of developing these housing units is much higher than the possible return from renting or selling these units at an affordable price. Therefore, a different approach is proposed by the author. This approach is based on a redefinition of the nature of this business. To explain this approach, one can look at a business example like computer printers. Selling these printers is not the main source to generate profit, rather selling the cartridges used in the printers is. Selling the printers is merely a way to create the market for the cartridges.

Similarly, we can redefine the business of affordable housing development. The existing standard business approach is:

*"We are in the **business of providing housing units** with minimum cost and*

*services. We will make profit by receiving the difference between the cost and the required revenue through some form of government subsidy"*

The author proposes to redefine the approach to be:

*"We are in the **business of creating a community** with a variety of needs. The created community should attract commercial activities. We sell these commercial activities and make a profit out of this"*

This fundamental change in approach impacts how a developer identifies the contents of a development program. While the standard approach focuses solely on the affordable housing units, the proposed approach creates interrelated activities that satisfy the different needs of a community of working residences in terms of workspaces, shopping areas, utilities and services, in addition to the required housing units. The developer's profit comes from selling or renting the commercial spaces and services that are now required to satisfy the needs of the created affordable housing community.

As such, a typical development using the proposed approach will have a number of profit-making components, outlined below, in addition to the affordable housing units. Clearly, having more of such components gives the impression of more revenue for the developer. Yet, there is always a maximum capacity for any community to have such profit-making components. Therefore, the key term in making such an approach successful is "interrelated activities" where the size of the profit-making components is associated with the size of the community created by the affordable housing units. These relationships are also shown below and are used to verify that the approach makes sense financially. The development components are:

- *Affordable housing units*: these are defined as units that are leased for a maximum of 33% of the minimum wage in Egypt. No down payment is required and the ownership of the units is transferred to the tenants after 30 years.
- *Retail spaces*: these are rented to those who provide the goods and services for the residents of the development. Its rentable area is calculated so that one housing unit requires one meter square of commercial space [2].
- *Office spaces*: these are assumed to be the main working space type for the residents of the development. Other working spaces such as industrial warehouses or hospitality facilities or others may be used. This depends on the location of the development and its surrounding economic prospects. The office

spaces are rented to businesses that employ the residents of the affordable housing units. It is assumed that each affordable housing unit has only one person employed by those renting the office spaces. A standard nine square meters of office spaces is assigned per person.

- *Luxury housing*: these are sold to people who own or manage the businesses operated in the development (retails and offices). It is assumed that every 20 affordable housing units (20 employees) require one luxury housing unit (one business owner or manager).
- *Transportation and utilities*: these are sold for the residents of the development.

The approach as explained above is supported by two supplementary ideas. The first is a technical one that propagates the use of green building technologies. The second is a social one that builds on the Egyptian culture and its prevailing religious drives.

From the perspective of the proposed approach, the use of **green building technologies** supports the approach in two ways:

- It creates a shift from a central infrastructure system to a local infrastructure system. Current green technologies allow the generation of energy on site from the abundance of solar energy available in Egypt. Also, underground water is available in almost all parts of Egypt with enough quantities for domestic water use. The waste water can be treated locally and reused. Such a shift removes the dependency on government-provided utilities from any proposed development (only external roads will be needed from the government). Hence, it reduces the cost of providing land by the government. Although this shift results in increasing the initial cost of the development, it enables the developer to sell these utilities (water and electricity) to the development users and to generate profit.
- It enables the selling of carbon credits in the world market. This can be a source of generating revenue for the developer.

**Egyptian culture** continues to be shaped by religion-based concepts that promote the care for the vulnerable portion of the society. This is evident in the existence of both historical and modern large endowments and numerous charity funds that address a variety of needs. It is also typical - for many in Egypt - to pay the religiously mandated 2.5% of their savings for charitable purposes. This cultural aspect supports the proposed approach in two ways:

- It avails funds that support the affordable housing development. For example, the paving of roads can be easily viewed as a "running charity" (the religious argument is outside the scope of this paper). This can reduce the initial cost of the development.
- It encourages the existence of profit-making developers that have charitable purposes. Those will reinvest their profit to develop more affordable housing projects. Their bottom line is achieving their social objective rather than just maximizing their profit.

### 3 FINANCIAL STUDY

The approach components along with the two supplementary ideas are translated to a workbook structure in Excel. This enables the testing of the approach using real financial data. The workbook structure is composed of six modules that are interrelated through a calculation engine as shown in Figure 1. These modules are:

#### 3.1 Development characteristics

This module identifies data such as the number of developed affordable housing units, luxury units, and the area of commercial activities. The module reflects the relationship among the different components of the development as discussed above.

#### 3.2 Financial data

This module identifies data such as the inflation rate, and the rate of increase in affordable housing rent. It is important to note here that the module assumes the following: 1) The increase in affordable housing rent is significantly lower than the inflation rate (to keep the housing units affordable). 2) The increase in commercial rent follows the inflation rate.

While these numbers can be modified in the module, the financial study used a 10% inflation rate, and a 3% increase in affordable housing rent. The used inflation rate is roughly the average in Egypt in the last 20 years [3].

This module also identifies - per unit - the cost data and the initial prices to rent and to sell the different units, spaces, and services in the development.

#### 3.3 Utilities and green technologies

This module calculates the energy and water consumption for housing and commercial spaces based on the characteristics of the development as decided in module one. It also estimates the quantity of carbon credits that can be sold. Various technical references are used for these calculations.

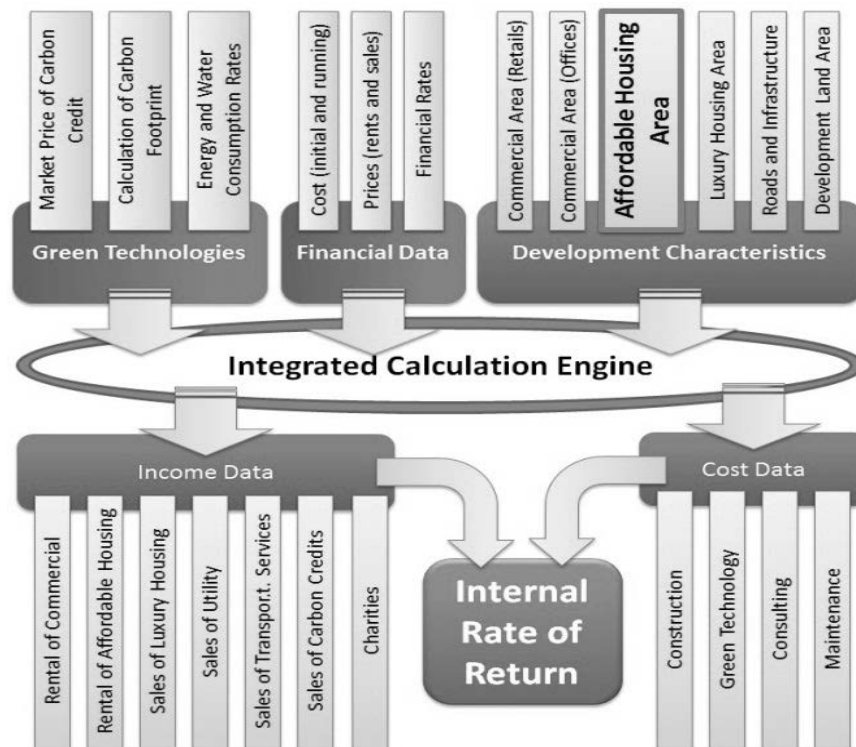

Fig. 1: Structure of the workbook used for the financial study.

### 3.4 Costs

This module uses the calculation engine to determine - for the whole development - the cost of construction, the cost of using green technology, the consulting cost, and the initial annual maintenance cost. The maintenance cost is a percentage of the development cost. This is essential to keep the development in a functional condition and to regularly replace and update equipment.

### 3.5 Incomes

This module uses the calculation engine to determine income from renting affordable housing and commercial spaces. It also calculates income from selling the luxury houses, utilities, transportation services, and carbon credits. In addition, it accounts for charitable financial contribution based on the Egyptian culture as mentioned above.

### 3.6 Internal rate of return (IRR)

Using the costs and incomes data calculated in the above two modules, this module generates the cash flow through a period of 30 years. This is the assigned default period for a feasibility study and it can be changed as needed. The first three years are assigned as the default period for construction and they mainly have a negative cash flow. Yet, some positive cash flow exists in this period as a result of selling the luxury housing units (over a period of five years – which is typical in Egypt). Starting from the fourth year, income is generated from the rent of commercial spaces, the rent of affordable housing, the sales

of utilities and transportation services. These values increase annually following the assigned inflation rate and other rates as mentioned above. Maintenance cost also kicks in as a negative cash flow and increases annually using the inflation rate. After 30 years, the affordable housing units are owned by their users. The office and retail spaces are sold for 10 times their annual rental value at the time. Water, electricity, and transportation facilities are also sold for 10 times their annual income. Using the described cash flow, this module calculates the Internal Rate of Return (IRR) for the development project.

## 4 RESULTS, AND ANALYSIS

The author assumed a development land area of one million square meters. The built area is the typical 20% of the land. Area calculations for the different components of the development follow the relationships mentioned above. The author collected the data for construction costs and the prices for renting and selling of real estate from several developers. Prices for electricity, water, and sewage treatment are those used in Egypt at the time of the study. The price of carbon credits is that which exists at the time of the study. A conservative assumption is made that only 1.0% of the rental value of the commercial spaces in the development will be donated for charitable purposes.

With the above data, the author used the workbook structure to generate a cash flow for 30



years and to calculate the IRR. The result is an IRR value of 18.19%.

However, the calculated IRR is based on some assumed input data. Therefore, the author performed several sensitivity analyses for the critical input data to check the resiliency of the calculated IRR. Figure 2 to Figure 5 show the impact of changing the inflation rate, the rental value for office spaces, the rental value of retail spaces, and the maintenance cost on the calculated IRR. Figure 2 indicates clearly the significant impact of the inflation rate on the IRR. This is understandable considering that this rate affects almost all income sources. Figure 3 shows the important impact of the rental value for office spaces. However, it is reasonable to state that the model is resilient to changes in these critical inputs as the value of IRR continues to be relatively good.

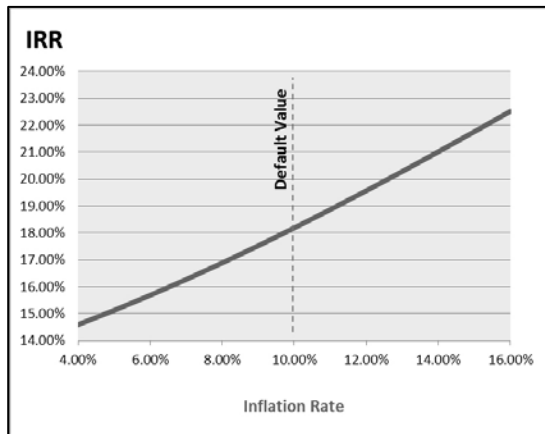

Fig. 2: Impact of the change in the inflation rate on the IRR.

Another important analysis is the breakdown of the calculated IRR to identify the importance of each income component. Figure 6 provides such a breakdown and it clearly shows that a significant portion of the return comes from the renting of commercial offices. Such a result is expected as it reflects the proposed approach. However, it also reflects the importance of having economic activities in the country. Such activities make the demand for the commercial offices (or other types of working spaces).

The results also show that selling carbon credits has a minor impact on the IRR. Meanwhile, the selling of utilities and particularly electricity has reasonable share in the IRR. However, the analysis of the cost and the income shows that the selling of utilities hardly covers the cost of the used green technologies needed to provide them. Nevertheless, the positive impact on the

environment as well as the independence from the government's supply of utilities are good incentives to use these technologies.

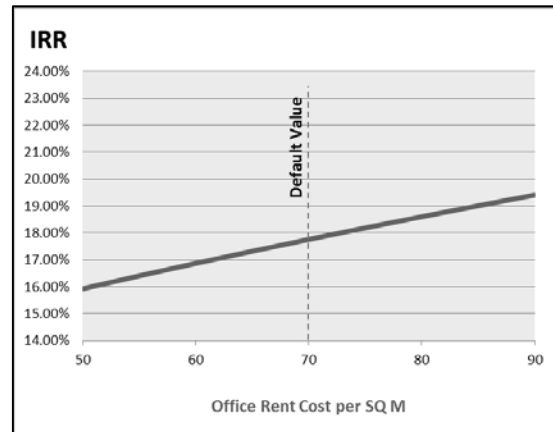

Fig. 3: Impact of the change in the office space rental value on the IRR.

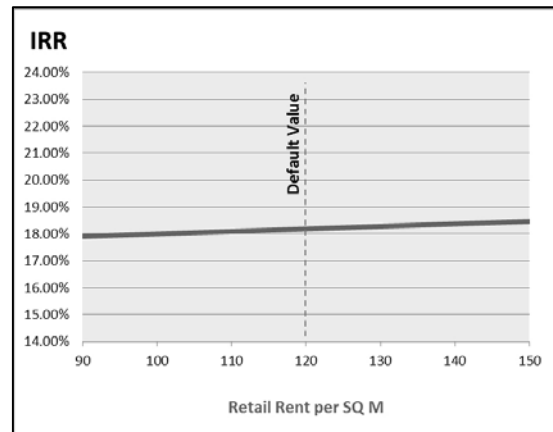

Fig. 4: Impact of the change in the retail space rental value on the IRR.

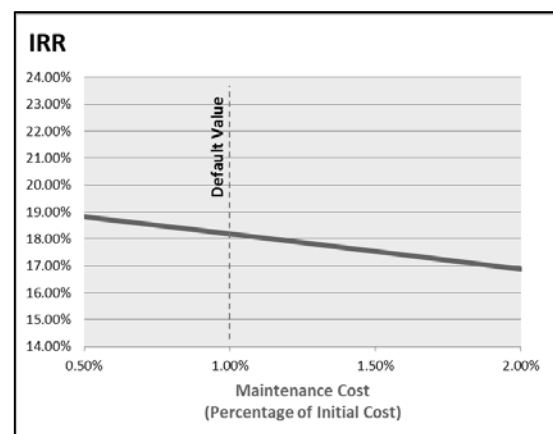

Fig. 5: Impact of the change in the maintenance cost on the IRR.

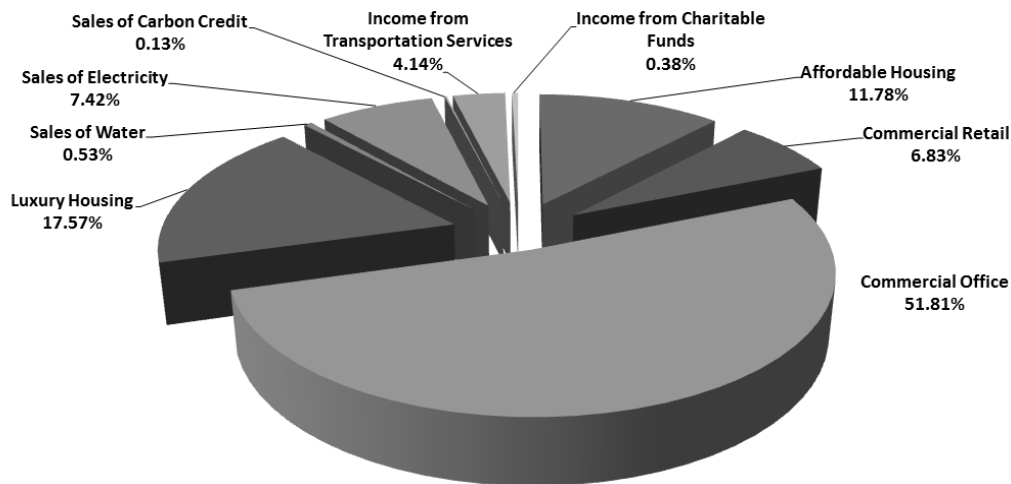

Fig. 6: Breakdown of the Internal Rate of Return.

## 5 CONCLUSION

To put the value of the calculated IRR in perspective, one needs to consider that banks in Egypt typically provide an interest rate of about 10% to 12% for three to five years fixed deposits. Therefore, it is reasonable to consider an IRR of about 18% as a profitable investment.

Nevertheless, an investor would consider associated risks to decide if such an IRR is worth the investment risk. Here comes the important role of two players to help support investments in developments that aim to solve the affordable housing problem:

- The first player is the government. With the proposed approach, the role of the government is no longer to provide subsidies to build affordable housing units; rather it is to minimize the risk for investors in such projects. This is done through reducing bureaucracy, providing accurate data, establishing a suitable legal framework, etc.
- The second player is the Egyptian culture. As explained above, this would encourage taking the risk in projects that are reasonably profitable but have a clear social agenda. Maximizing the profit and minimizing the risk is not necessarily the ultimate investment objective of investors who are also driven by a social agenda that promotes the care for the vulnerable portion of the society.

Following the proposed approach, developers will create clusters of communities in regions in the country with a promising economic growth. The development program of these clusters will integrate affordable housing, retail and work spaces, and luxury housing. These clusters will also be independent of government provided infrastructure and free from government

subsidies. As profit can be made from these developments, more of such clusters will be built to satisfy the demand and gradually solve the affordable housing problem in Egypt.

## 6 SUMMARY

This paper presents an approach for developing profitable affordable housing projects without the need for government subsidies. A financial study that used real data to implement the approach shows that a good Internal Rate of Return can be achieved and hence the continuous development of such projects can be sustained. The main reason for the success of the approach is viewing the project development as an activity to create a community rather than an activity to construct a number of affordable housing units. Unlike the current government approach that segregates the land assigned to affordable housing, luxury housing, and commercial activities, the proposed approach promotes the integration of these activities.

## 7 REFERENCES

1. CAPMAS, Central Agency for Public Mobilization and Statistics, Retrieved November 29, 2015, from <http://www.capmas.gov.eg/default.aspx>
2. Khoi, A., Successful Shopping center Development (2007), Retrieved September 24, 2013, from <http://www.gyoder.org.tr/zirve7/Z7sunum/Anthony.Khoi.Successful.Shopping.pdf>
3. Trading Economics (2014), Retrieved February 11, 2014, from <http://www.tradingeconomics.com/egypt/inflation-cpi>

Zurich, June 15-17 2016  
Sustainable Built Environment (SBE) Regional Conference



## Expanding Boundaries: Systems Thinking for the Built Environment

### ENVIRONMENTAL IMPLICATIONS AND OPPORTUNITIES OF DIGITAL FABRICATION

I. Agustí-Juan<sup>1\*</sup>, G. Habert<sup>1</sup>

<sup>1</sup> ETH Zürich, Zürich, Switzerland

\*Corresponding author; e-mail: agusti@ibi.baug.ethz.ch

#### Abstract

Society's increasing concern for sustainability aspects is inducing the emergence of digital technologies to overcome the inefficiency and reduce environmental impacts in product manufacturing. As the use of digital processes such as 3D printing grows, innovative applications into large scale processes are emerging. The combined methods of computational design and robotic fabrication are demonstrating a large potential to expand architectural design and transform conventional construction processes. But, the most impressive impact may be their contribution to the improvement of sustainability in construction. The challenge of digital fabrication at building scale is to achieve efficiency in parameters such as material use, energy demands, durability, GHG emissions and waste production over the entire life cycle of a building. The goal of this paper is to investigate the environmental implications and opportunities of digital fabrication in construction. The research focuses specifically on measuring the flow of materials, embodied energy and potential environmental impacts associated with digital fabrication processes. With this objective, the case study of a wooden roof digitally fabricated is presented. The project was assessed according to the Life Cycle Assessment (LCA) framework and compared with a conventional wooden roof with similar function and structural capacity. The analysis highlighted the importance of material-efficient design to achieve high environmental benefits in digitally fabricated architecture. This research is the initial step towards the establishment of a knowledge base and the elaboration of guidelines that help designers to make more sustainable choices in the implementation of digital fabrication in construction.

#### Keywords:

Digital fabrication; LCA; Sustainability; Environment; Material efficiency

### 1 INTRODUCTION

The construction sector is the responsible of high environmental impacts, such as high energy consumption, solid waste generation, GHG emissions and resource depletion [1]. Responding to the society requirements, a new type of construction practice is needed to overcome the inefficiency and lack of interoperability and promote sustainable design practices.

The potential to fabricate elements directly from design information has transformed many design and production disciplines [2]. Specifically, 3D printing processes are becoming an integral part of modern product development [3]. As interest in additive manufacturing grows, research is

beginning to reveal potential large-scale applications in architecture and construction [4]. But their potential contribution to the improvement of sustainability in construction should be argued. The challenge of architectural scale additive fabrication is more than simply "scale up" 3D printing. The issues of size, material use, energy demands, durability, CO<sub>2</sub> emissions and waste production over the life cycle of a building, must be recognized as the priorities of any architectural project.

The goal of this study is to investigate the impacts and opportunities of digital fabrication to advance achievements in sustainable construction. The research focuses specifically on measuring the

flow of materials, embodied energy and potential environmental impacts associated with digital fabrication processes. The methodology of assessment focuses on the LCA comparison of digital fabrication with conventional construction, with specific priority placed on methods of additive fabrication and robotic construction processes at architectural scale. Comparative assessments with conventional construction are performed, with priority placed on new methods of additive fabrication and full-scale robotic construction in architectural processes.

## 2 METHODOLOGY

The methodology selected for environmental assessment was the Life Cycle Assessment (LCA) framework present in the standards ISO 14040-44: 2006 [5, 6]. LCA method has a well-established use in different sectors and its application is increasing in the construction sector as it represents an appropriate approach for environmental evaluation and optimization of construction processes [7]. The LCA was implemented in the software SimaPro 8 using the Ecoinvent v2.2 database [8] and the method Recipe Midpoint (H) [9]. The selected impact categories considered were climate change (kg CO<sub>2</sub> eq.), ozone depletion (kg CFC-11 eq.), human toxicity (kg 1.4-DB eq.), water depletion (m<sup>3</sup>), metal depletion (kg Fe eq.) and fossil depletion (kg oil eq.).

The method was focused on the comparison of digital fabrication with conventional construction with the same function. From the different projects classified, we selected for this study a case study of a building element where digital fabrication enables additional functions embedded in the structure. The integration of these functions adds an evident arduousness on the environmental evaluation due to the difficulty on the performance of a LCA comparison with conventional construction. Specifically, the definition of the functional unit is critical due to the difficulty on finding a conventional system that concentrates the functions integrated in the digitally fabricated structure. Therefore, for each particular case study, a detailed study to tailor the functional unit is needed.

## 3 CASE STUDY

The project selected for the assessment was “The Sequential Roof” (Gramazio Kohler Research, ETH Zürich, 2010-2015). This wooden structure consists of 168 single trusses that compose a 2,308 square meter freeform roof design. The structure composed by 100-150 cm timber slats have been robotically assembled to create large-scale load bearing structures. The project demonstrates the potential of combining digital fabrication technology applied at full architectural

scale with a local and natural building material. The mechanized assembly of the wood structures makes possible a reduction on the construction time from manual assembly and it has a potential interest with regard to the use of recycled waste wood [10].

### 3.1 System boundaries and functional unit

The life cycle of the case study was focused on the production phase in accordance to a cradle-to-gate analysis, from the extraction of raw material up to the construction site. “The Sequential Roof” integrates additional finishing and acoustic functions in its wooden structure, allowing the elimination of additional elements such as hanging ceilings, which typically perform these functions in conventional roofs. Considering these characteristics, the two functional units compared were 1 m<sup>2</sup> of this computationally designed and robotically assembled wooden roof and 1 m<sup>2</sup> of conventional wooden roof structure with hanging ceiling. Both elements shared the same structural capacity (15 meter of span), wooden aesthetics for interior finishing and similar acoustic properties.

### 3.2 Data collection

The Sequential Roof is composed by 384 m<sup>3</sup> of C24 fir/spruce wood robotically assembled using in total 815,984 nails (Fig. 1). The prefabrication process of the 168 trusses was carried out by a special robot in factory. Due the lack of data from this robot, the impact of the technologies production was calculated considering two robotic arms and a desktop computer [11]. Finally, we included the energy consumed during construction, considering 12 hours/truss.

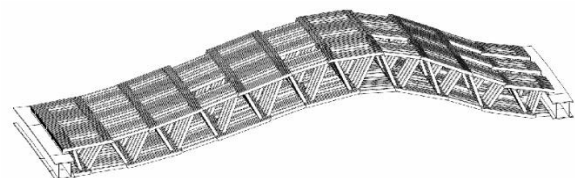

Fig. 1: Section of “The Sequential Roof” (Gramazio Kohler Research, ETH Zurich, ETH Zürich).

The conventional roof structure was formed by conventional Glulam spruce beams and joists. The joists were connected to the beams with galvanized steel hangers. The wood structure was covered by 19 mm of water-proof particle board attached with steel nails. In addition, a hanging ceiling finished the structure and protected acoustically. The ceiling was composed by laminated wood boards, 5 cm of rock wool acoustic insulation and a hanging structure of galvanized steel. Additional roof layers such as waterproofing or thermal insulation were not included in the evaluation, as they were considered equal in both structures.

### 3.3 Results

#### *Environmental impact of digital fabrication process*

The results from the environmental assessment were broken down into four processes: timber production, steel production, digital technologies production and electricity used for construction. Fig. 2 indicates that more than 95% of environmental impacts associated with the robotically fabricated roof are caused by materials production. Simultaneously, the graph shows that the impact of construction energy is lower than 10% in all the indicators. This fact is attributed to the production process in Switzerland, where the primary energy supply has small shares of natural gas and coal and a 22% of renewable sources [12]. Similarly, the relative impact of the production of digital technologies is less than 2%.

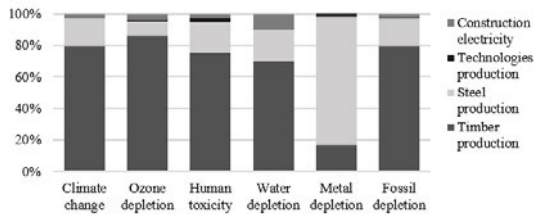

Fig. 2: Relative contributions to the environmental impacts of The Sequential Roof production.

#### *Comparative LCA with conventional construction*

Subsequently, we compared the life cycle of the digitally fabricated roof structure with the conventional system. Fig. 3 graphically depicts the environmental benefits of The Sequential Roof production process. Specifically, the difference between the environmental impacts of both construction systems is between 30-40% in all categories. For example, in climate change the CO<sub>2</sub> emissions of The Sequential Roof are more than 40% lower than the conventional roof compared.

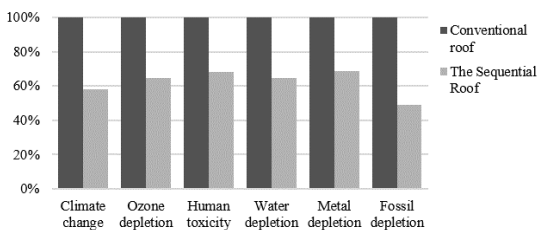

Fig. 3: Comparison of the environmental impacts of The Sequential Roof and the conventional roof structure.

### 3.4 Sensitivity analysis

In order to evaluate the variability of the results depending on the constructive solution, the projects were compared adapting different hanging ceiling solutions in the conventional roof. Originally the ceiling typology was composed by steel structure, rock wool insulation and laminated wood. We introduced a variation on the materiality and thickness of the last two. For the indoor layer

two solutions were assessed: 16 mm laminated wood and 12 mm plywood. And the materiality of the insulation layer varied between rock wool, glass wool and cellulose fibre in 4 different thickness between 40-100 mm. In total 24 additional solutions were considered for the conventional roof and compared with the environmental impact of The Sequential Roof. Fig. 4 shows the results of the sensitivity analysis performed.

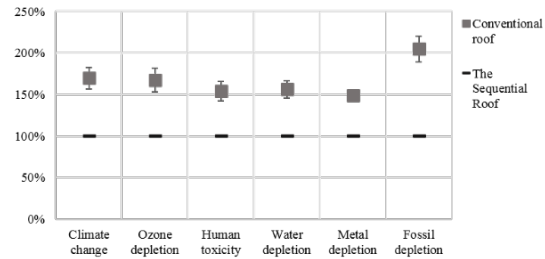

Fig. 4: Comparison of The Sequential Roof and conventional roof. Error bars represent standard deviation of the impacts depending on the hanging ceiling solution considered.

The graph locates most of the impacts of the conventional roof approximately 50% higher than The Sequential Roof. In fossil depletion the impact of the conventional roof duplicates the digitally fabricated roof due to a larger use of resources during materials production. In conclusion, the variability of the impacts depending on the hanging ceiling solution considered had a low influence on the results.

## 4 DISCUSSION

### 4.1 Materials production vs construction

Digital fabrication has fostered social and economic changes in manufacturing, but it still must mature to bring significant environmental benefits to the life cycle of buildings. The project evaluated in this paper is a clear example of the potential benefits that the implementation of computational design and robotic fabrication may bring to the construction sector. The results of the evaluation evidenced that the energy and resource consumption of robotic fabrication processes contributed minimally to the global environmental impact of the project compared to materials manufacturing process.

In the cradle to gate analysis presented in this paper, the environmental impact of the construction phase was reduced to the electricity consumption of the robot during construction. The conventional use of machines, materials and work were excluded from the LCA comparison. As previous studies have proven, the construction phase (including the use of temporary materials and equipment on-site) has a very small contribution to the life-cycle impacts of a building. For example, [13] clearly stated that direct emissions derived from on-site construction were

relatively small (2.42%) compared to the indirect emissions embedded in the production of building materials (97.58%). Similarly, the results presented in [14], showed that the materials production accounted around a 10% in energy consumption and CO<sub>2</sub> emissions while the construction phase had an environmental impact around 1.5% compared to the overall life-cycle emissions. Moreover, related literature such as [15] and [16] demonstrated that GHG emissions derived from the construction phase were even more reduced in prefabricated processes.

Therefore, the environmental impact of the construction process was assumed negligible compared to the building material production. In consequence, the case studies were simplified assuming that the impacts of construction works were equal and negligible in both architectural elements compared and therefore excluded. We focused on the additional impacts induced by the use of digital fabrication and showed that these additional impacts were also negligible. In a complete LCA comparison of digital fabrication and conventional construction all impacts should be included.

#### 4.2 Integration of additional functions

During the analysis performed in this paper, we observed that in many projects, digital fabrication allows the integration of additional functions in the structure. This integrated performance, such as thermal or acoustic functions, brings an added value to architecture [17]. These innovative digital construction process can contribute to achieve potential material savings, elimination of waste, or reduction of economic and labour costs associated with conventional construction. However, in some architectural projects, additional functions can increase the requirement of material for the primary function, which might be environmentally disadvantageous. For example, in [18] we compared a self-shading brick façade fabricated with digital technologies with a conventional brick façade. In that case study, an important factor in the comparison was the additional % of brick needed for the self-shading effect, which was equivalent to a thin layer of insulation in the conventional system. The results showed that the integration of additional functions in digital fabrication did not provide environmental benefits because the equivalent function in the conventional system had a low environmental impact.

On the contrary, the integration of acoustic and finishing functions in the structure of “The Sequential Roof” brought an important reduction of material and environmental impacts compared to a conventional roof. Even considering different materiality solutions in the conventional roof, the environmental benefits of the digitally fabricated building element were considerable. These benefits were mainly related to the combination of

different functions in a single element, which allowed a more efficient and material-reductive construction process. In order to prove this evidence, we carried out a study on the environmental impacts of the conventional roof production (Fig. 5).

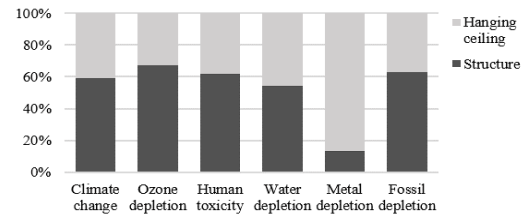

Fig. 5: Relative contributions to environmental impacts of the conventional roof production.

The analysis shows that the hanging ceiling is responsible of approximately 40% of the emissions. Therefore, digital fabrication brought high environmental benefits because the integrated additional functions were equivalent to a conventional element with high environmental impact. Even if the material requirement for the structure of the digitally fabricated product itself might have a higher material requirement as such.

## 5 CONCLUSION

In this paper we focused on the analysis of a case study that uses digital fabrication as an innovative construction process. A wooden roof was selected and compared to a conventional building element with a similar function. The Sequential Roof demonstrated the advantages of computational design and robotic assembly for a more efficient production of structural elements. The analysis proved that the impacts of digital fabrication were negligible compared to the materials production process. Therefore, any digital fabrication process that can save materials compared to a conventional fabrication process will allow to reduce the environmental impact. Simultaneously, the study highlighted the potential environmental opportunities of integrating additional functions in the structure of digital fabrication elements. However, the integration of multiple function allows great savings only when these functions have a large environmental impact. In conclusion, sustainable design in architecture through digital fabrication must focus on the functional and structural optimization oriented towards resource efficiency.

## 6 ACKNOWLEDGMENTS

This research was supported by the NCCR Digital Fabrication, funded by the Swiss National Science Foundation (project number 51NF40\_141853).

## 7 REFERENCES

1. Ortiz, O., F. Castells, and G. Sonnemann, *Sustainability in the construction industry: A review of recent developments based on LCA*. Construction and Building Materials, 2009. **23**(1): p. 28-39.
2. Dunn, N., *Digital fabrication in architecture*. 2012, London: Laurence King Publishing Ltd.
3. Hague, R., I. Campbell, and P. Dickens, *Implications on design of rapid manufacturing*. Proceedings of the Institution of Mechanical Engineers, Part C: Journal of Mechanical Engineering Science, 2003. **217**(1): p. 25-30.
4. Gramazio, F., M. Kohler, and S. Langenberg, *FABRICATE: Negotiating Design & Making*. 2014, Zurich: gta Verlag.
5. ISO, *14040: Environmental management—life cycle assessment—principles and framework*. 2006.
6. ISO, *14044: Environmental management—life cycle assessment—requirements and guidelines*. International Organization for Standardization, 2006.
7. Cabeza, L.F., et al., *Life cycle assessment (LCA) and life cycle energy analysis (LCEA) of buildings and the building sector: A review*. Renewable and Sustainable Energy Reviews, 2014. **29**: p. 394-416.
8. Hischer, R., et al., *Implementation of Life Cycle Impact Assessment Methods. Final report ecoinvent v2.2 No. 3*. Swiss Centre for Life Cycle Inventories, Dübendorf, CH, 2010.
9. Goedkoop, M., et al., *ReCiPe 2008*. A life cycle impact assessment method which comprises harmonised category indicators at the midpoint and the endpoint level, 2009. **1**.
10. Gramazio Kohler Research. *The Sequential Roof*. 2014 [cited 2015 27/08/2015]; Available from: <http://gramaziokohler.arch.ethz.ch/web/e/forschung/201.html>.
11. Williams, E.D. and Y. Sasaki. *Energy analysis of end-of-life options for personal computers: resell, upgrade, recycle*. in *Electronics and the Environment, 2003. IEEE International Symposium on*. 2003. IEEE.
12. International Energy Agency, i., *Energy Policies of IEA Countries, Switzerland*. 2012.
13. Hong, J., et al., *Greenhouse gas emissions during the construction phase of a building: a case study in China*. Journal of Cleaner Production, 2014. **103**: p. 249-259.
14. Junnila, S., A. Horvath, and A.A. Guggemos, *Life-cycle assessment of office buildings in Europe and the United States*. Journal of Infrastructure Systems, 2006. **12**(1): p. 10-17.
15. Mao, C., et al., *Comparative study of greenhouse gas emissions between off-site prefabrication and conventional construction methods: two case studies of residential projects*. Energy and Buildings, 2013. **66**: p. 165-176.
16. Wen, T.J., H.C. Siong, and Z. Noor, *Assessment of embodied energy and global warming potential of building construction using life cycle analysis approach: Case studies of residential buildings in Iskandar Malaysia*. Energy and Buildings, 2015. **93**: p. 295-302.
17. Moussavi, F., M. Kubo, and S. Hoffman, *The function of ornament*. 2006, Barcelona: Actar.
18. Agustí-Juan, I. and G. Habert. *Environmental assessment of Digital Fabrication: contribution of IT design to the overall life cycle impacts*. in *Proceedings of the 32nd CIB W78 Conference on Construction IT*. 2015. Eindhoven, Netherlands.







## Expanding Boundaries: Systems Thinking for the Built Environment

### A NOVEL PERSPECTIVE ON THE AVOIDED BURDEN APPROACH APPLIED TO STEEL-CEMENT MAKING JOINT SYSTEM

M. R.M. Saade<sup>1\*</sup>, M. G. da Silva<sup>2</sup>, V. Gomes<sup>1</sup>

<sup>1</sup> University of Campinas, Campinas - SP, Brazil

<sup>2</sup> Federal University of Espírito Santo, Vitória – ES, Brazil

\*Corresponding author; e-mail: marcellarms@hotmail.com

#### Abstract

Recycling of ground granulated blast furnace slag (ggbfs), a steelmaking process coproduct, in cement making has been typically seen as beneficial for both industry sectors involved, for the destination of an industrial waste to replace and reduce raw material intake of a second manufacturing process. Within Life Cycle Assessment (LCA) methodology, the distribution of impacts between a product and its coproduct shall follow ISO 14044's guidelines. Impact distribution in multifunctional processes remains, however, as one of LCA's most controversial methodological issues. This paper analyses how multifunctional modelling methods distribute steelmaking environmental loads between pig iron and bfs, and their influence on LCA results for ordinary Portland cement and two types of blended cements with high ggbfs content commercialized in Brazil. SimaPro 7.3 supported LCA using CML 2001 (baseline) impact evaluation method. Impact allocation, by definition, induces considerable impacts on bfs. Using the avoided burden approach, impact values in all categories decreased with increased ggbfs content in cement. Though the 'avoided burden approach' succeeds to a major recycling benefit – raw material preservation – in products' life cycle modelling, it fails to distribute it properly and is not adapted to the waste user. By acknowledging that new loads arise and are neutralized over recycling implementation, this approach not only distributes environmental benefit among the partnering industries that enable recycling, but also provides a more complete and refined description of recycling implications and actual (net) avoided burden, that, among others, can better inform strategic decision-making by the involved industries.

#### Keywords:

LCA; cement; allocation; system expansion; avoided burden

### 1 INTRODUCTION

Impact distribution in multifunctional processes is one of LCA's most controversial methodological issues given that it highly influences the study's final result. Ekvall and Finnveden [1] define a multifunctional process as an activity that fulfils more than one function: a production process generating more than one product, a waste management process with more than one waste flow, or a recycling process providing waste management and material production.

The vague nature of ISO 14044:2006 [2] proposed guidelines, combined with a growing desire to follow a "life cycle approach", without a clear notion of what it means, has led to confusion regarding what an LCA might or might

not accomplish and how it fits into a strategic approach to assure environmental sustainability [3]. As a result, it has become increasingly common to find conflicting LCA approaches, many times evaluating the same product, but achieving different results due to the lack of common methodological choices among practitioners and of clear scientific background supporting such decisions.

#### 1.1 The challenge of modelling multifunctional process

A multifunctionality problem occurs in LCA when a process fulfils one or more functions for the investigated product's life cycle, and a different function (or functions) for other product(s) [1]. This poses the issue of sharing and distributing

material and energy flows – and their respective environmental loads – between multiple functions.

To solve a multifunctionality problem, ISO 14044:2006 [2] suggests a three-step procedure. Firstly, the distribution of impacts between a product and coproduct based on a specific criterion (i.e. allocation) should be avoided “*wherever possible*”, either by dividing multifunctional processes into sub-processes or by expanding the product system to include the additional functions related to the by-products. Secondly, in the cases where allocation cannot be avoided, the standard prescribes that system inputs and outputs should be divided based on the “*underlying physical relationships between them*”. Finally, if those physical relationships are not easily identified to enable partitioning, then the inputs and outputs are to be attributed in a way that reflects other relationships between the products and functions, such as their economic value.

Each multifunctional modelling method presents its perks and losses. Mass allocation is quite straightforward, using easily calculated and relatively constant values. However, in some industrial processes the mass of product and coproduct generated is substantial – which is exactly the case for construction sector industries – so a large amount of the environmental load is transferred to the coproduct user, removing a great deal of the main product’s loads. Economic value allocation users defend that all industrial activities are guided by economic principles, which justifies adopting the same principles for impact distribution. The most common critic to that method is that economic value information is very sensitive to market fluctuations, which harms results reliability over time. Pelletier and Tyedmers [4] highlighted the current economic system’s inability to adequately account for changes in environmental amenities. For that reason, those authors state that market information rarely incorporates relevant environmental information – which justifies their questioning of LCA results that are highly influenced by economic information.

Previous literature review spanning over the past 10 years of LCA practice [5] confirmed the lack of consensus regarding the choice of a given method over others or the appropriateness of one single distribution approach to all multifunctionality cases. It also indicated a massive use of the avoided burden approach, which is most likely related to its application’s readiness, and to the fact that it avoids allocation, as is recommended by the international standard.

One relevant argument refers to compliance of the different distribution methods to mass and energy conservation laws. Weidema and Schmidt [6] state that *system expansion always respects*

*the mass and energy conservation laws, while allocation nearly always fails to do so.* According to those authors, since allocation “breaks” the original system into two or more artificial systems according to the allocation criterion adopted, the only balance observed is given by that criterion, i.e. when mass regulates allocation, only mass conservation is respected. On the other hand, Chen et al. [7] justify choosing mass and economic value allocation criteria to assess impacts of using additives in concrete making, by affirming that system expansion (through the avoided impact approach) does not respect mass conservation laws *when the product and by-product are considered together.* The arguments from each side are supported by either one case-specific example [6] or a hypothetical example designed by author-defined equations [7]. Both explanations can be contested in different contexts and perspectives that render them not applicable.

The arguments found in literature regarding compliance with conservation laws are still too scarce to discard a given distribution method. In fact, to minimize the influence of impact distribution on LCA results, published literature gathers suggestions of different approaches for specific sectors, such as the allocation method for the cement industry proposed by [8].

## 1.2 Research context and justification

The Brazilian cement industry has a tradition of benefiting from the industrial synergy with the steelmaking sector. Normalized in 1964, the replacement of clinker by ground granulated blast furnace slag usually generates two types of Portland cements: the blended Portland cement (CP II-E-32), which contains up to 35%, in mass, of ggbs, and the blast furnace Portland cement (CP III-32), with up to 70% of ggbs in mass.

National studies aiming to measure the environmental loads of cement with bfs as clinker replacement so far have typically considered this slag merely as a consequence of the pig iron-making process, therefore with no impact attributed to it [9]. Research that potentially contributes to a better understanding of impacts and or benefits that arise from such a well-established industrial synergy is crucial.

This paper analyses the appropriateness of multifunctional modelling methods predicted in ISO 14044:2006 [1] to distribute environmental loads between pig iron and bfs produced in the steelmaking process; as well as the influence that modelling choices have on LCA results for different blended cement types commercialized in Brazil. We further build upon such analysis to propose an adjustment of the avoided burden approach used in the system expansion method.

## 2 METHODOLOGICAL APPROACH

### 2.1 LCA's Goal and scope definition

The performed LCAs fall into the cradle-to-gate category, i.e., the use and end of life stages are not considered, since the study's main focus is limited to modelling the multifunctional process (steelmaking) and the process that uses the analysed coproduct (cement making). Subsequent phases fall out of the research's scope. SimaPro 7.3 was the support platform chosen and CML 2001 (baseline) was adopted for the impact assessment stage. The adopted functional unit was 1 ton of cement.

### 2.2 Inventory analysis

Table 1 summarizes technical properties and tools used to model cement making processes.

	CP I-S-32	CP II-E-32	CP III-32
<b>Functional unit</b>		1 ton	
<b>Amount of ggbfs as clinker replacement</b>	5%	30%	66%
<b>National standard</b>	NBR	NBR	NBR
<b>Data input</b>	5732:1991 30 kg CaSO <sub>4</sub> 920 kg clinker 50kg ggbfs	11578:1991 30 kg CaSO <sub>4</sub> 670 kg clinker 300kg ggbfs	5735:1991 30 kg CaSO <sub>4</sub> 310 kg clinker 660kg ggbfs
<b>Impact evaluation method</b>	CML baseline 2001		
<b>LCA platform</b>	SimaPro 7.3		

Table 1: Technical properties, considerations and tools used in the cement LCAs.

Data for the production processes' modelling came from national and/or local reports. When national data were unavailable, the corresponding processes found in the SimaPro built-in Ecoinvent database were adapted to better represent the Brazilian context. To model ggbfs generation, data from one specific steelmaking company were collected from spreadsheets reported to a local environmental agency.

Impact distribution between steel and ggbfs was performed using ISO 14044 [1] predicted methods: (i) mass allocation; (ii) economic value allocation; and (iii) system expansion through the avoided burden approach. Next, authors propose a revised avoided burden approach, so-called the 'net avoided burden approach'.

### 2.3 Impact assessment

CML 2001 (baseline) method evaluates predefined impact categories covering impacts on natural resources, human health and ecosystem quality. The method allows for results'

normalization, but in this paper authors chose to dismiss that feature in order to minimize possible assumptions and uncertainties associated with normalization.

## 3 RESULTS PRESENTATION AND DISCUSSION

### 3.1 ISO-recommended impact distribution methods

Data from the steelmaking company indicated that the pig iron production for a given year was 5.6 million tons, while 1.38 million tons of ggbfs were generated. Also, pig iron was sold at \$487/ton at the time, while ggbfs was sold at \$18,20/ton. These values defined the allocation percentages.

The use of mass allocation implied in an increase in acidification potential, photochemical oxidation and abiotic depletion when increasing the amount of ggbfs replacing clinker Portland. All other impact categories decreased with the reduction of clinker in cement composition. Economic allocation, however, led to the decrease of all impact categories, noting, however, that acidification potential, photochemical oxidation and abiotic depletion presented more discrete decreases. This indicates that these are more intensive categories in the steelmaking process that generates the blast furnace slag. Using the traditional avoided impact approach, all categories decreased in proportion to the amount of ggbfs added to cement. This is expected, since this distribution method focuses on better system modelling other than on partitioning impacts.

### 3.2 The proposed approach

Allocation simply transfers part of the multifunctional process' impact to the product system that incorporates the coproduct. It does not consider elementary recycling benefits, such as scarcity of the replaced raw material, and avoidance of end of life impacts by reinserting a coproduct into productive uses.

Contrastingly, the avoided burden approach succeeds to include a major recycling benefit – i.e. virgin raw material preservation – in products' life cycle modelling. Still, it fails to distribute it properly and is not adapted to the waste user [5]. On one hand, the avoided impact is discounted only from the multifunctional process that generated the coproduct. The waste user is kept out of the equation and not only does not receive any benefit, but also absorbs processing, transportation and further recycling related impacts, while enabling that material cycle closing. On the other hand, the proposed approach avoids this distortion by adding or deducing from the joint system all loads that are caused or avoided by raw material replacement (Fig. 1, Fig. 2 and Equation 1).

In Figures 3, 4 and 5, the results, for 1 ton of each type of cement, using the proposed approach are normalized in relation to the avoided burden approach. Due to limited data available at the time of writing, our calculations have only included coproduct processing impacts.

Similar to the avoided burden approach, impacts in all categories decrease proportionally as ggbs content increases. The processing loads would necessarily be calculated to model cement making, so that there is no added complexity, whereas the net prevented loads embed a more cohesive concept.

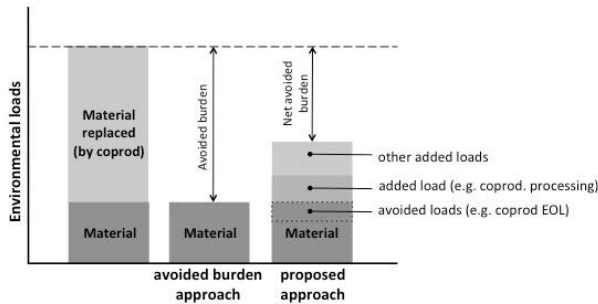

Fig. 1: Proposed vs. avoided burden approach.

$$I_{net} = I_{subst} - [I_{proc} + I_{other} - I_{EOL}] \quad (1)$$

Where  $I_{net}$  is the 'net' avoided burden;  $I_{subst}$  is the impact avoided by replacing a giving product with a coproduct;  $I_{proc}$  is the coproduct processing impact,  $I_{EOL}$  is the coproduct's end-of-life impact, if not productively used; and  $I_{other}$  are all other loads that may arise from coproduct use, e.g. transportation loads if the coproduct is not locally available.

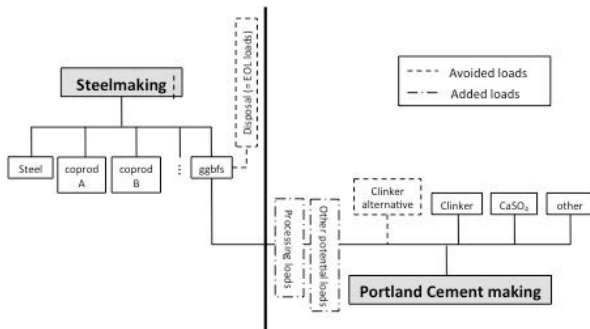

Fig. 2: Joint system according with the proposed approach.

By acknowledging that new loads arise and are neutralized over recycling implementation, this approach not only distributes environmental benefits among the partnering industries that enable recycling, but also provides a more complete and refined description of recycling implications and actual (net) avoided burden, that, among others, can better inform strategic decision making by the involved industries.

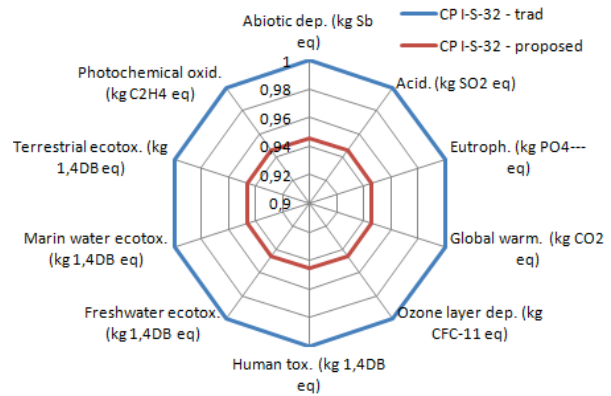

Fig. 3: Impacts of 1 ton of cement CP I-S-32, using avoided burden vs. proposed approach.

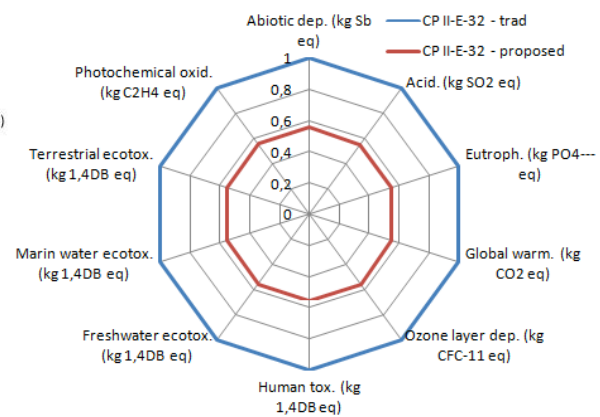

Fig. 4: Impacts of 1 ton of cement CP II-E-32 using avoided burden vs. proposed approach.

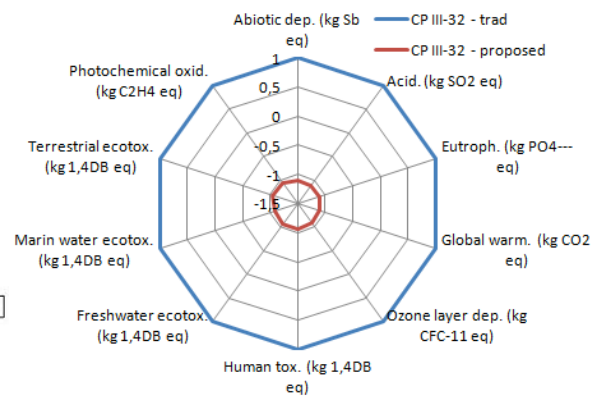

Fig. 5: Impacts of 1 ton of cement CP III-32, using avoided burden vs. proposed approach.

#### 4 CONCLUSIONS

There is still a long way to go before scientific consensus regarding the choice of multifunctional modelling methods is reached. The traditional avoided burden approach manages to capture the virgin raw material preservation, while offering easiness to understand and use. The calculation revision proposed here envisions a more complete overview of the balance between

avoided (e.g. landfilling) and generated (e.g. coproduct processing) burdens related to coproduct use. Insertion of different aspects in the net avoided burden calculation are currently under study, and are expected to provide a framework for further adjustment propositions.

## 5 ACKNOWLEDGMENTS

The authors thank FAPESP, FAPEX and CNPq for their generosity.

## 6 REFERENCES

1. Ekvall, T.; Finnveden, G. Allocation in ISO 14041 – a critical review. *Journal of Cleaner Production*, 2001, 9: p. 197-208.
2. International Standard ISO 14044 (2006<sub>b</sub>) Environmental management— life cycle assessment—requirements and guidelines.
3. Curran, M. A. Strengths and Limitations of Life Cycle Assessment. In: Klöpffer (Ed.). *Background and future prospects in Life Cycle Assessment*. 2014. London: Springer. pp. 189-206.
4. Pelletier, N.; Tyedmers, P. An ecological economic critique of the use of market information in life cycle assessment research. *Journal of Industrial Ecology*, 2011, 15(3): p. 342-354.
5. Saade, M; Silva, M; Gomes, V. The use of impact distribution methods on multifunctional processes' LCA: a systematic literature review, in V Congresso Brasileiro em Gestão do Ciclo de Vida. 2016: Fortaleza, Brazil (in press).
6. Weidema, B. P.; Schmidt, J. H. Avoiding allocation in life cycle assessment revisited. *Journal of Industrial Ecology*, 2010, 14(2): p. 192-195.
7. Chen, C. et al. LCA allocation procedure used as an incitative method for waste recycling: An application to mineral additions in concrete. *Resources, Conservation and Recycling*, 2010, 54(12): p. 1231-1240.
8. Habert, G. A method for allocation according to the economic behaviour in the EU-ETS for by-products used in cement industry. *The International Journal of Life Cycle Assessment*, 2013, 18(1): p. 113-126.
9. Saade, M.; Silva, M.; Gomes, V. Appropriateness of environmental impact distribution methods to model blast furnace slag recycling in cement making. *Resources, Conservation and Recycling*, 2015, 99: p. 40-47.





## Expanding Boundaries: Systems Thinking for the Built Environment

### AIR DEHUMIDIFICATION WITH NOVEL LIQUID DESICCANT SYSTEM

J. Pantelic<sup>1,2</sup>, E. Teitelbaum<sup>2</sup>, S. Kim<sup>3</sup>, H. Guo<sup>3</sup>, A. Schlueter<sup>1</sup>, A. Rysanek<sup>1</sup>, F. Meggers<sup>3\*</sup>

<sup>1</sup>ETH Zurich, Institute of Technology in Architecture, John-von-Neumann Weg 9, CH-8093 Zurich

<sup>2</sup>Princeton University, Civil and Environmental Engineering, School of Engineering, 08540 Princeton, NJ, USA

<sup>3</sup>Princeton University, School of Architecture, S03 Architecture Building, 08540 Princeton, NJ, USA

\*Corresponding author; e-mail: fmeggers@princeton.edu

#### Abstract

Liquid desiccant systems have the potential to remove water from air efficiently. This dehumidification leverages the chemical affinity of liquid desiccants to absorb water from the air instead of classical energy and exergy intensive mechanical dehumidification. Desiccants remove water through chemical absorption, and do not require the low temperatures needed to drive condensation on cooling coils. There are both solid and liquid desiccant systems that have been implemented for buildings with the former being used in wheels to move moisture in and out of tangential air streams, and the latter being used to extract, transport and remove water in a fluid loop. Both have limitations with solids struggling with limited mobility, and liquids with corrosiveness and volatility. But the benefit of eliminating latent cooling temperatures of  $<8^{\circ}\text{C}$  and focusing on sensible cooling at  $>14^{\circ}\text{C}$  could cut cooling energy in half. We consider the potential of a new liquid desiccant system consisting largely of Alkoxyated Siloxane. We characterize its water absorption and desorption characteristics, and we discuss the potential suggested by these results for application in a hypothetical building system design.

#### Keywords:

Liquid desiccant, dehumidification, energy savings, building system design,

### 1 INTRODUCTION

Less than a century ago humans did not have access to air conditioning in buildings, and for the first few decades of its existence it was only a novelty in movie theatres. Today many people would say they cannot live without it. Tropical countries like Singapore would not be considered developed without the massive air conditioning infrastructures. Now air conditioning has provided a comfort anticipated by residents including tropical natives. Even tourists often expect to be able to “escape the heat” of the location and climate they have travelled to experience.

But in tropical environments it is not really cooling, as one would traditionally think of it, that is desired, or even that is really delivered. It is the high humidity in the tropics that drives discomfort, and the primary operation of air conditioning

systems is humidity removal, defined as the latent cooling demand. In fact, the latent cooling demand for air conditioning in the tropics is more than half of the total cooling demand, which means that making the air colder is actually a less significant part of the air conditioning process than reducing humidity.

Because cooling makes up a major fraction of energy demand for buildings, it is important to critically think about how this demand is met. Traditionally, air conditioning systems use metal cooling coils that are cooled below the dew point to cause condensation of water out of incoming outdoor air streams. This requires temperatures much colder than the actual sensible air temperature one would read on a thermostat. The colder temperatures for dehumidification reduce the performance of the refrigeration

machine, causing more electricity to be used per unit cooling delivered, further increasing the impact of the latent cooling on energy demand of the building systems. Therefore, addressing latent cooling at the system level provides a great opportunity to significantly reduce energy demand.

An alternative method of dehumidification is to use desiccant materials that chemically absorb water out of the air stream. These systems do not require the excessively cold temperatures, but they do require an alternative system design, and present a variety of other challenges arising from their physical nature and deployment opportunities.

We evaluate, characterize, and hypothesize the use of a novel liquid desiccant for achieving the benefits of more efficient dehumidification while overcoming some of the challenges common to desiccant systems. We consider its implementation in the context of the tropical environment, and compare its hypothetical operating characteristics to a pilot building system we recently completed in a Singapore school using solid desiccant sensible and latent energy recovery.

## 2 BACKGROUND

It has been shown that energy can be saved by separating the latent cooling from sensible cooling (Teitelbaum et al., 2015) [1]. The quality of the the cooling energy needed to mechanically remove moisture from the air through condensation is higher than that need to maintain the dry bulb temperature in the space. The latter space cooling can be achieved most effectively through delivery in large surface areas at temperature closer to room air. We have demonstrated the ability to provide the sensible cooling to a space using radiant cooling panels at a higher temperature, thereby separating it from latent cooling and generating it at a higher temperature (Meggers et al., 2013) [2]. This allows the chiller to run at a higher efficiency for that sensible demand, which in a humid climate ranges from 40 to 60% of the cooling demand. Low exergy system design focuses on minimizing excessive temperatures because a heat pump or chiller has a fundamental thermodynamic performance relationship that increases its efficiency as less extreme temperatures are used (Meggers et al., 2013) [2]. The integration of cooling systems into surfaces like radiant panels chilled beams to increase the heat exchange at reduced temperature differences and also facilitates architectural and spatial design opportunities that increase system efficiency, space availability and design flexibility have been demonstrated in our pilot building project in Singapore (Schlueter et al., 2016) [3].

Traditionally latent cooling requires temperatures below the dew point to cause condensation to remove the water. These temperatures are typically around 6 to 8 °C. At this temperature saturated air at 10 to 12 °C can easily be produced. When this air is distributed to the building it heats up resulting in air at roughly 20 to 25 °C with humidity 40 to 50%, achieving standard comfort criteria. In older systems or very inefficient contemporary ones, additional heat is used to reheat the subcooled air. In places like Singapore this is not allowed, which is good for efficiency, but it leads to challenges in correctly predicting the ability of air to heat back up in ducts and mix into rooms. Many people have experienced the excessively cold temperatures from mechanically dehumidified cooling air when they unfortunately sit under an air diffuser to which air is being supplied without being adequately reheated (Lstiburek and Harriman, 2009) [4].

We argue that a system that avoids excessive cold temperatures and focuses on delivering cooling at temperatures closer to room air will be both more efficient and more comfortable. Still, just splitting the latent cooling from the sensible does not eliminate these temperatures, as dehumidification is required. Desiccant provides a solution to replace the condensing latent cooling with chemical absorption. The main benefit is the desiccant can be regenerated using excess heat rather than cold, and heat is more readily available in cooling environments. The main challenge is moving these chemical desiccants effectively in and out of air streams. Solid desiccants have provided solutions for recovery of latent energy across supply and exhaust streams as is being done in our pilot implementation in Singapore (Schlueter et al., 2016) [3]. Solid desiccants can be regenerated, but generally need higher temperatures and are spatially constrained by the need to physically move the solid material (usually by rotating it on a wheel between air stream). We are therefore interested to explore new opportunities for utilization of novel liquid desiccants.

Glycols and halide salts are currently used as liquid desiccants. Glycols are highly volatile and require constant systems refilling which significantly increases system operation cost. On the other hand, halide salts are not volatile, but they are corrosive, hence require parts of the system to be made out of titanium or some other materials that do not corrode. For halide salts the carry over from the liquid into the air stream represents a significant problem. Once desiccant droplets enter airstream supplied to the indoor environment they can cause health problems for building occupants and degradation of materials.



### 3 METHODS

The liquid desiccant is a 70-90 wt% alkoxyated siloxane mixture, with the remaining 10-30 wt% consisting of polyol. We performed two types of experiments to test properties of novel liquid desiccant.

When absorption of liquid desiccant was measured, liquid desiccant was placed in a beaker and exposed to the air at 25 °C and relative humidity (RH) of 80 %. This air condition corresponds to the humidity ratio of 15.9 g/kg and partial water vapour pressure of 2535.4 Pa. A mixing magnet was placed into the beaker to ensure that whole volume of desiccant is mixed and absorb water vapour from air. Change in weight of the desiccant system was recorded every 60 s using scale with  $\pm 0.001$  g accuracy. Change of weight was recorded until 5 consecutive measurements could not be distinguished within the scale accuracy. Air in contact with desiccant surface was quiescent, with restricted movement above contact surface and fully mixed with the fan in the conditioning chamber.

In order to measure desorption of liquid desiccant 3 % wt of deionized water was added to the liquid desiccant and mixed with the mixing magnet. Water was desorbed at the air - liquid interface surface. Air used in desorption process had temperature of 23C and RH 27.4 % relative humidity. This air condition corresponds to humidity ratio of 5 g/kg and water vapour partial pressure of 813 Pa. Change of weight was measured every 60 s using a scale with  $\pm 0.001$  g accuracy. Similar to the previous experiment air in contact with the liquid desiccant surface had 3 flow regimes.

#### 3.1 Concept development

We intend to develop air conditioning system that can be integrated with facade and floor and provide sufficient dehumidification for the building in the tropics. This type of integrated system will provide dehumidification of air immediately at the indoor - outdoor interface. This allows ventilation to be introduced into the building immediately at the facade and reduces necessity for application of large centralized air handling unit. Air used for ventilation in the tropics has very high latent load, hence goal of our concept is to totally decouple dehumidification and sensible cooling. This paper will address part of the concept that focuses on the air dehumidification.

## 4 RESULTS

### 4.1 Absorption rates

X - axis on Figure 1 represents time and y - axis on represents increase in weight of liquid desiccant - water solution due to the absorption of water vapour from the air. Results on Figure 1 show that air movement above the contact

surface significantly influences absorption. For the quiescent air case, water vapour moved through boundary layer due to diffusion and partly natural convection. When air in the contact with liquid desiccant surface was mixed with the fan, boundary layer absorption was higher. Absorption difference between quiescent and mixed air increased through time.

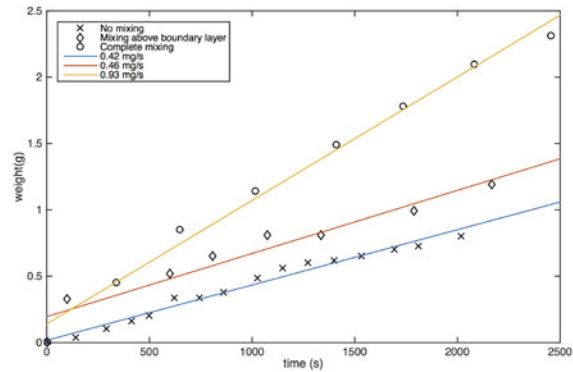

Fig. 1: Adsorption of liquid desiccant as a function of different airflows above contact surface.

Results on Figure 2 show the absorption for different mixing conditions of the desiccant: one with mixing and the other one without. It shows that for absorption of water vapour into the desiccant there are two distinct regimes, a resistance-limited regime and a contact-area limited regime. Initially when concentrated desiccant is exposed to humid air, we are in an area-limited regime as the desiccant is concentrated and the majority of the collisions between desiccant and water vapour will result in a successful absorption interaction (blue line in Figure 2). However, as the desiccant becomes saturated, fewer collisions will result in absorption (red line in Figure 2). This is the basis for a standard langmuirian adsorption kinetics model. As the surface area available for water molecules decreases with desiccant saturation, there will be fewer physical spaces available for effective collisions that lead to absorption. In this second regime, a resistance-limited regime, absorption rates are now limited by the frequency of effective collisions. While having more surface area would still increase rates, the dominant resistance is now a molecular phenomenon. Results point out that moving from limited resistance to limited contact area regime decreases slope almost 3 times from 0.93 to 0.32.

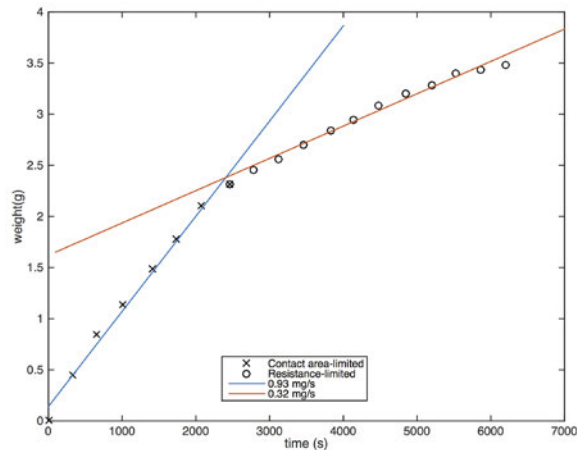

Fig. 2: Adsorption of liquid desiccant in limited resistance and limited contact area regime.

Results in Figure 3 show desorption rates for liquid desiccant in a beaker with fully mixed air above the free surface. Results suggest that desorption is slightly slower process when compared to adsorption where about 0.7 gram is removed per second for desorption and 1 gram is added per second for absorption, both for the faster resistance limited regime, but the desorption could also be limited by the boundary layer. The rate in the slower site limited regime is comparable for absorption and desorption so the desiccant kinetics are probably controlling for both with a rate of about 0.4 grams per second.

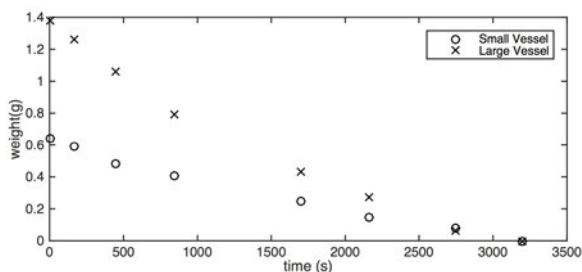

Fig. 3: Liquid desiccant desorption characteristics in two different vessels.

## 5 DISCUSSION

Based on the water vapour absorption and desorption rates we calculated necessary surface area to provide dry ventilation air in the tropics. It was assumed that outdoor air had to be dehumidified from humidity ratio of 20 g/kg to 10 g/kg. For single occupant ventilation requirement of 30 m<sup>3</sup>/h required contact area is 3.8 m<sup>2</sup>. If we deploy membrane tubes of 1 mm diameter with 0.5 m length 7600 tubes would be required to build such an exchanger. Based on the calculated area we considered development of absorber that will increase mass transfer coefficient compared to absorption from the mixed air above the contact surface. We intend to utilize increase of Sherwood number with the

controlled flow of air over the air - liquid desiccant contact surface. This will reduce resistance introduced by the air boundary layer. Reduction of surface area required for dehumidification is very important factor for integration of this system. We considered hollow fibre membrane exchanger. Membrane will be made of hydrophilic material that has tendency to absorb water from air. Hydrophilic membrane was chosen as a material because it had high permeability, hence although it physically separates air from the desiccant it doesn't add to the system's resistance. Hollow fibre hydrophilic membrane exchange also prevents carryover issue hence supplied air will be safe for occupants and building materials.

## 6 CONCLUSION

From the results presented following conclusions can be derived:

- Air movement above free surface of liquid desiccant substantially affect mass transfer rate. Increase of the mixing above liquid desiccant free surface increases mass transfer rate.
- Absorption of water vapour into the desiccant show existence of two distinct regimes, a resistance-limited regime and a contact-area limited regime. Resistance limited regime has higher mass transfer rate compared to contact area-limited regime.
- Desorption rates are 50 % lower compared to absorption rates for liquid desiccant tested in our experiments.
- Based on per occupant ventilation requirement of 30 m<sup>3</sup>/h and necessary removal of 10 g/kg of water per kilogram of air, we calculated that required air - liquid desiccant area is 3.8 m<sup>2</sup>. Our future research will be focused on methods to increase dehumidification and reduce necessary area.

## 7 REFERENCES

1. Teitelbaum E., F. Meggers, G. Scherer, P. Ramamurthy, L. Wang, E. Bou-Zeid, ECCENTRIC Buildings: Evaporative cooling in constructed Envelopes by transmission and Retention Inside Casing of Building, 6<sup>th</sup> International Building Physics Conference, IBPC 2015, Torino, Italy.
2. Meggers F., J. Pantelic, L. Baldini, E.M. Saber, M.K. Kim, Evaluating and adopting low exergy system with decentralized ventilation for tropical climates. *Energy and Buildings*, 2013. 67: p. 559-567.
3. Schlueter A., A. Rysanek, F. Meggers, M. Mast, M. Bruehlisauer, C.K. Wee, C. Miller,

J. Pantelic, 3-for-2: Realizing Spatial, Material and Energy Savings through Integrated Design, CTBUH – in press.

4. Lstiburek J. and L. Harriman, The ASHRAE Guidebook for buildings in hot and humid climate. 2009 ASHRAE.





## Expanding Boundaries: Systems Thinking for the Built Environment

### DEEP RENOVATIONS WITHIN SMART ASSET MANAGEMENT

E. Nippala<sup>1\*</sup>, T. Vainio<sup>2</sup>

<sup>1</sup> Tampere University of Applied Sciences, Kuntokatu 3, FI-33520 TAMPERE, Finland

<sup>2</sup> VTT Technical Research Centre, Tekniikankatu 1, FI-33720 TAMPERE, Finland

\*Corresponding author; e-mail: Eero.Nippala@tamk.fi

#### Abstract

To cut emissions of building stock, the European Union had set minimum requirements to the energy efficiency of buildings in Energy Performance of Buildings Directive. Member States are encouraged to promote energy upgrading for the higher level by Energy Efficiency Directive, EED Article 4. In this, instead of setting new requirements, focus is on the operating environment. How it could better promote the voluntary deep renovations. The Paris Agreement on climate change imposes increasingly ambitious targets and speeds up progress towards carbon-neutral societies.

Finding energy-saving measures that do not increase the cost of living is nevertheless important for all households. Everyone agrees that incorporating measures that improve energy performance into normal structural repairs is the most sensible approach. This makes the measures the most economical to implement. From the perspective of all levels of education and businesses' product development, it is important to agree on what "normal structural repairs" encompass, in order to be able to target investments correctly.

To fulfil this kind of information need, the ASPE 15 (Need for the renovation of the housing stock) model has been developed. The main input data is the building typology and number of buildings in each category. In co-operation with stakeholders and by means of case studies, both the usual and the deep renovation measures have been identified. The first results show significant changes in the content of future renovation activities. There are changes both in renovation activities and where they are located.

#### Keywords:

Asset management; housing stock; energy efficiency; deep renovation; upgrading

### 1 INTRODUCTION

At the beginning of 2014, the European Commission published climate and energy policy targets for 2030. These include a reduction in greenhouse gas emissions to 40 per cent below the 1990 level, and an EU-wide binding target for renewable energy of at least 27 per cent [1].

The action plan for the implementation of the Europe 2020 strategy, published in 2011 [2], focuses on improving the energy performance of buildings in connection with renovation projects. The Article 4 of the European Energy Efficiency Directive adopted in 2012 [3] urges Member States to mobilise investment in the deep

renovation of the national residential and commercial building stock.

According to the Paris Agreement [4], all countries will, in the future, have a responsibility to plan and implement cuts to their emissions, and to report these cuts openly and transparently. Each country can choose its own approach to implementation according to its level of development, but more and more ambitious targets need to be adopted over time.

Buildings currently account for approximately 40 per cent of total energy consumption in Europe. Over half the building stock that will be in existence in 2050 has already been built. Energy performance of existing buildings will need to be

improved, and fossil fuel emissions will have to be cut for Europe in order to meet the targets set in the EU's climate and energy policy. The means to achieve these goals include minimising heat loss, recovering heat from extracted air, increasing the efficiency of electricity use and promoting renewable sources of energy, such as geothermal heat.

Only a minority of the housing stock is owned by central government. This means that the majority of renovation decisions are made by private individuals, real estate companies or local governments. The rights of property owners are protected by law. In other words, the central government cannot obligate property owners to improve the energy performance of their properties. Instead, they must be enticed into renovating their properties voluntarily.

When the European Energy Performance of Buildings Directive (EPBD) [5] was transposed into national legislations, there was speculation that excessively strict requirements would lead property owners to neglect the maintenance of their properties: property owners would be discouraged from undertaking renovation projects at all if these led automatically to considerable extra cost.

## 2 GOALS

The main goal is to establish, on a macro level, how the current building stock can be made more energy efficient. The first task is to identify the normal structural repairs that will need to be carried out between 2015 and 2035 due to migration, population ageing, and increasing health and safety requirements in buildings. The second task is to determine how measures aimed at improving energy performance can be incorporated into these repairs.

## 3 SCOPE

There are two ways to renovate residential buildings. The majority of renovations, both quantitatively and qualitatively, are driven by residents' wishes, and they focus on improving buildings' appearance and upgrading systems. These kinds of improvements are not a part of this project.

This project focuses exclusively on technological improvements stemming from the wearing, ageing and breakdown of structures and systems. Such needs for improvement can be predicted by means of the service life of various structures and systems. [6]

## 4 METHODOLOGY

The two methods adapted in the project are interactive process with stakeholders and statistical analysis.

### 4.1 Interactive Process

In order to ensure that property owners chose to introduce energy-efficient solutions into their existing properties, the requirements needed to be acceptable to those who ultimately made the decisions. Without interaction, unrealistic goals will be easily set, as has been the case in the Netherlands [7].

In this project, the provisions were, therefore, formulated in cooperation with property owners. They were asked to share information on issues such as the cost-effectiveness of different measures. Many solutions that are relatively inexpensive and easy to incorporate into new developments can be difficult and costly to introduce into existing building stock. One example would be installing air-conditioning in a building that lacks the necessary air ducts. On the other hand, energy efficiency can be improved considerably by simple, inexpensive measures, such as balancing and adjusting central heating systems.[8]

### 4.2 Statistical Analyses

The renovation needs of residential buildings can be identified with the help of the so-called ASPE model [9] [10]. This model has been developed specifically for examining the need for technological improvements and operational upgrades in buildings. In this research project, an evolution version ASPE 15 model was developed for reviewing energy efficiency improvements.

The variables used in the model are the type, age and location of buildings. The type and age of a building determine what renovations need to be carried out and how much is likely the cost. Evaluations need to take into account the fact that different construction technologies have been used in different eras, and, on the other hand, the fact that even buildings of similar age can incorporate structures that have widely divergent useful lives. This Finnish model has a lot of similarities with Norwegian housing stock model as it regards renovation [11]. The difference is to bring coming new construction as input data from an other model.

Location determines whether renovations are worthwhile, i.e. whether the building will also have a use in the future. Sometimes it makes sense to modernise buildings to meet new needs. One example is incorporating a lift to make a building better suited to older people. The development of building service systems has added new features to old buildings over time. The current drive to improve the energy performance of buildings will create a whole new wave of modernisation across old properties' building service systems.

## 5 RESULTS

### 5.1 Empty units

There are a significant number of buildings that could potentially be made more energy efficient in connection with normal structural repairs. The question raised in discussions with interest groups, however, is whether all buildings are worth renovating. According to the banking sector, there are areas where buildings cannot be accepted as collateral for mortgages in areas where population is decreasing.

Population forecasts for these areas were consequently examined more closely. It was found that these areas have what is known as a "greying population".

### 5.2 Pre-fabricated apartment buildings

The industrialisation of construction (pre-fabrication over on-site construction) has changed building technology significantly. Energy upgrades are needed both in old buildings constructed on site and in slightly newer, industrially constructed buildings. Different approaches are needed to renovate the two types of buildings.

Due to their thick, solid walls, older buildings actually consume less energy, but renovating them is more expensive due to the high proportion of manual labour involved. Renovating older buildings also costs more due to the fact that there are more areas that require attention than in newer buildings.

Buildings constructed during the early years of industrialisation have the worst energy performance of all buildings. Energy efficiency could therefore be increased the most by focusing on buildings that were constructed during the early years of industrialisation. Developing industrial renovation models, products and services specifically for these kinds of properties is a worthwhile investment.

## 6 DISCUSSION

### 6.1 Empty units

Urbanisation is a growing trend all around the world. Both natural population growth and migration contribute to urbanisation. Migration means that an increasing number of residential buildings in the countryside are left empty. From the perspective of material efficiency, this is an unfortunate but inevitable scenario. The question of whether there will be demand for homes in an area in the future can be answered by comparing population forecasts to the existing building stock.

If no demand can be seen for a property in the future either, the most energy-efficient solution is to abandon the building. Eliminating excess empty space would increase the energy performance of the national economy. Demolition

may be an option if a property has stood empty for a long time and the owner is unable to find an alternative use for the building. Buildings on inefficiently developed plots in growing urban areas have occasionally been demolished to free the land for new housing with more floor space. New buildings are more energy-efficient than the ones demolished so as to make way for them.

If there does appear to be demand but only for a relatively short period of time, it is prudent to avoid deep renovations. However, no opportunity to improve energy performance should be ignored altogether.

### 6.2 nZEB and deep renovation

Article 4 of the EED requires member states to establish a long-term strategy for mobilizing investment in the renovation of the national stock of residential and commercial buildings, both public and private. This strategy must encompass 'policies and measures to stimulate cost-effective deep renovations of buildings, including staged deep renovations'.

Nearly Zero Energy Building, nZEB target will add a so-called nearly Zero Energy Building Renovation, nZEBR complimentary element to deep renovation strategy. Hitherto, deep renovations have been voluntary. In future, they will gradually become mandatory. nZEBR has different definitions. One definition is to reduce the primary energy consumption by 75 per cent compared to the pre-renovation status. An alternative definition for nZEBR is to satisfy at least 50 per cent of energy consumption by renewable forms of energy. There are also other options. So far, there is no clear definition of nZEB renovation [12].

Based on the results of this study, the 75 per cent target is only justifiable for buildings of extremely low energy performance at the moment. A European study [13] arrived at the same conclusion. The promotion of smart and integrated nZEB renovation measures in the European renovation market, NEZER project concluded that the target is only feasible for buildings constructed before the year 1980. For newer buildings, the target is too ambitious. According to our study, no line can be drawn on the basis of the year of construction, as some older buildings were actually renovated with energy efficiency in mind during the 1970s energy crisis.

Increasing the percentage of renewable energy to meet the target is relatively easy in respect of single family houses. The target is also technologically feasible in multifamily houses, but more difficult to implement in practice. What makes renovating multifamily houses especially challenging is the fact that decisions need to be made collectively and the fact that some of the necessary measures may be dependent on a centralised energy supplier. The majority of

multifamily houses are located in densely populated areas, where there is little room for harvesting renewable energy. It is nevertheless important to remember that renovating buildings up to the nZEB target is only ever justifiable if there is long-term demand for them.

### 6.3 Self-paying renovations

Housing costs need to be kept in check even in the face of demands to improve the energy performance of buildings. One way to curb housing costs is to lower energy consumption (heating, cooling, ventilation, hot water, and lighting). The Promotion of smart and integrated nZEB renovation measures in the European renovation market (NEZER study) demonstrated that energy consumption can be lowered by between 30 per cent and 80 per cent. There is more potential in old buildings than in newer ones. Lower energy consumption can help to finance building renovations and keep housing costs under control. From this perspective, renovation technologies need to be as affordable as possible.

Energy efficiency can only be improved if the renovation project is carried out professionally and with up-to-date technology from start to finish. Clients need to specify what they wish to achieve with the renovation in terms of energy efficiency; the engineers need to find the means to meet these objectives, and the builders need to carry out the repairs and ensure that the energy performance targets set are reached in practice. Regulations and recommendations need to be supported by high-quality engineering and building know-how. Emphasis must be placed on the importance of careful planning and skilled builders in achieving a high-quality end result.

The energy performance of buildings is a goal and research topic shared by many countries. New technologies and solutions come from investing in a common objective. New solutions need to be tested in real environments, and this requires that regulations are waived so as to enable the testing of breakthrough technologies.

The concept of energy efficiency as an integral part of all renovations should be emphasised by incorporating it into the curriculum at all levels of construction education. Energy efficiency and renovations are essential elements of life cycle management, a discipline that has so far largely been neglected in education in favour of courses focusing on new construction. Courses are needed for both young students and workers, and for both new recruits and professionals who have already established themselves in the industry.

Material efficiency as part of life cycle management should be factored into teaching. Courses focusing on renovation projects should include lessons on ways to improve energy

efficiency as well as new technologies. Virtual learning resources would also be a way of making the information accessible to individuals already in the labour force.

Cost of the renovation work will get higher even there are new technologies in use. Just now the price of the energy is decreasing. The combination of these things will decrease cost-effectiveness of the renovation work. For ordinary people the payback time is more important than carbon dioxide decreasing. During times where there are low energy cost and high renovation cost there are difficulties to activate deep renovation which reduce energy use of buildings.

## 7 SUMMARY

In order to reach climate and energy targets set to building sector, measures need to encompass the majority of building stock. There is a lot of potential to lower energy consumption in theory, but in practice, there are a number of obstacles. The problem lies in the fact that most of these kinds of decisions rest with private individuals and many buildings are not worth energy conservation.

Property owners cannot be obligated to improve energy performance by renovating structures and systems that are otherwise serviceable. This is why the way forward is to encourage property owners to introduce these kinds of improvements in connection with normal structural repairs and system upgrades. This is also the most cost-effective way to improve the energy performance of existing buildings.

Decisions on renovations need to take into consideration whether buildings will have a use in the future. Population ageing and urbanisation will see more and more buildings left empty in the near future. Deep renovations in these kinds of buildings are probably not worth the investment.

The concept of energy efficiency as an integral part of all renovations should be emphasised by incorporating it into the curriculum at all levels of construction education. Energy efficiency and renovations are essential elements of life cycle management, a discipline that has so far largely been neglected in education in favour of courses focusing on new development. Courses are needed for both young people and more mature students, and for both new recruits and professionals who have already established themselves in the industry.

## 8 REFERENCES

1. 2030 Energy Strategy. 2014, European Commission. [referred 17.1.2016] <http://ec.europa.eu/energy/en/topics/energy-strategy/2030-energy-strategy>



2. Energy Efficiency Plan 2011. European Commission, [referred 17.1.2016] [http://ec.europa.eu/clima/policies/strategies/2050/docs/efficiency\\_plan\\_en.pdf](http://ec.europa.eu/clima/policies/strategies/2050/docs/efficiency_plan_en.pdf)
3. Energy Efficiency Directive EED. 2012, European Commission [referred 17.1.2016] <http://ec.europa.eu/energy/en/topics/energy-efficiency/energy-efficiency-directive>
4. Paris Agreement. 2015, European Commission [referred 17.1.2016] [http://ec.europa.eu/clima/policies/international/negotiations/future/index\\_en.htm](http://ec.europa.eu/clima/policies/international/negotiations/future/index_en.htm)
5. Energy Performance of Buildings Directive EPBD. 2010, European Commission [referred 17.1.2016] <http://ec.europa.eu/energy/en/topics/energy-efficiency/buildings>
6. Nippala, E. The need for refurbishment of housing stock and its programming, master thesis (Asuinrakennusten perusparannustarve). 1989, Tampere. Tampere University of Technology.
7. Visscher, H., Majcen, D., Itard, L. Energy saving policies for housing base on wrong assumptions. Open House International 39.2 (Jun 2014): 78-83
8. Vainio, T., Nippala, E., Hekkanen M. & Nissinen K. Long-term strategy for mobilising investment in the renovation of the national stock of residential and commercial buildings, both public and private (Deep renovation strategy) 2014, Brussels, European Commission.
9. Nippala, E. & Jaakkonen, L. The need for refurbishment of housing stock: description of the ASPE model (Asuinrakennusten perusparannustarve: ASPE -mallin menetelmäkuvaus ja laskelma 1990-luvun perusparannustarpeesta). 1993, Helsinki. Finnish Housing Board.
10. Lehtinen, E., Nippala, E., Jaakkonen, L. & Nuuttila, H. Residential buildings 2025 – new and refurbished (Asuinrakennukset vuoteen 2025 Uudistuotannon ja perusparantamisen tarve). 2005, Tampere. VTT Technology Research Centre of Finland.
11. Sandberg N., Sartorib, I. & Brattebø H. Using a dynamic segmented model to examine future renovation activities in the Norwegian dwelling stock. Energy and Buildings 82 (2014) 287–295.
12. COHERENO, nZEB criteria for typical I single - family home renovations in various countries. 2013, BPIE [referred 17.1.2016] [http://bpie.eu/wpcontent/uploads/2015/11/nZEB\\_Criteria\\_for\\_renovation\\_COHERENO.pdf](http://bpie.eu/wpcontent/uploads/2015/11/nZEB_Criteria_for_renovation_COHERENO.pdf)
13. NEZER, Promotion of smart and integrated nZEB renovation measures in the European renovation market [referred 17.1.2016] <http://www.nezer-project.eu>





## Expanding Boundaries: Systems Thinking for the Built Environment

### A MULTI-CRITERIA APPROACH FOR THE ASSESSMENT OF HOUSING RENOVATION STRATEGIES

O. Pombo<sup>1\*</sup>, K. Allacker<sup>2</sup>, B. Rivela<sup>3,4</sup>, J. Neila<sup>1</sup>

<sup>1</sup> Department of Construction and Technology in Architecture (DCTA), School of Architecture (ETSAM), Technical University of Madrid (UPM), Avda. Juan de Herrera 4, 28040 Madrid, Spain

<sup>2</sup> Department of Architecture, Katholieke Universiteit Leuven, Kasteelpark Arenberg 1, 3001, Leuven, Belgium

<sup>3</sup> inViable Life Cycle Thinking, Don Ramón de la Cruz 89, 28006 Madrid, Spain.

<sup>4</sup> Department of Organizational Studies and Human Development. National Polytechnic School. Av. Ladrón de Guevara E11-253, Quito, Ecuador

\*Corresponding author; e-mail: olatzp@alumnos.upm.es

#### Abstract

The building sector is well known to be one of the key energy consumers worldwide. The majority of the current European housing stock was built during 1940-1970s, with low standards especially with regard to energy performance. The challenge now is to act in this stock.

In this paper, a multi-criteria methodology is proposed for the comparative analysis of retrofitting solutions. First, environmental impacts and financial costs are evaluated via a life cycle approach. Secondly, Life Cycle Assessment (LCA) and Life Cycle Cost (LCC) are combined through the Pareto optimization method. For this, environmental impacts are expressed in monetary values.

To illustrate the applicability of our approach, a case study has been selected: the renovation of a representative housing block from the 60s located in Madrid. Three scenarios have been proposed for the analysis of energy saving measures: scenario 1, where typical solutions used in Spain are applied; scenario 2, where strategies to achieve energy requirements fixed by Spanish regulation are assumed; and scenario 3, where Passive House standard is achieved. Energy saving measures are therefore defined for each scenario considering roof, facade and windows.

Results show how housing renovation involves important benefits, not only from the environmental point of view but also from the financial perspective. For the building typology analysed, located in Madrid, the current retrofitting strategies are not optimal from an environmental point of view. The necessary extra investment for the improvement of the envelope with a higher insulation thickness (8%) is arguable taking into account the extra environmental and financial savings (45% and 87% respectively).

#### Keywords:

Housing renovation; life cycle assessment (LCA); life cycle cost (LCC); retrofitting; monetary valuation

## 1 INTRODUCTION

Nowadays, it is broadly recognized that the improvement of the energy efficiency of buildings is an urgent and important challenge. In Spain, 54% of the housing stock was built before 1980, i.e. before the first regulation concerning energy efficiency in buildings [1]. This large stock is a consequence of the high housing need in the

middle of the last century, in a context with a low industrial production and without any comfort standards. The main effort should be hence focused on the renovation of this stock.

During the last years, different programs have been conducted in order to promote housing renovation in Spain. However, requirements to get the subsidies have focused mainly on the

reduction of the energy consumption during the use phase.

With the aim to explore how efficient the current practices of retrofitting are, a multi-criteria methodology was proposed combining LCA and LCC. The assessment of the solutions currently used was illustrated by a representative case study in Madrid, Spain.

## 2 MATERIALS AND METHODS

### 2.1 Case study

As it has been mentioned, the renovation of a representative housing block from the 1960s located in Madrid was selected as a case study. Current strategies used in Spain were analysed in terms of efficiency by applying the multi-criteria approach. Different scenarios were analysed

from the Business as Usual scenario (BAU), through the requirements of the Spanish Building Regulation [4] up to the Passive House standard.

#### *Selection of a representative housing block*

The most representative typology of the Spanish housing stock is the multifamily housing block built between 1950 and 1980, which represents 43% of the residential stock [1]. Based on an in-depth analysis of the housing stock in Madrid [2], a representative housing block has been identified.

The studied building is a ten-story building, containing 120 dwellings of 2 and 3 bedrooms, with a net floor area of 49 and 64 m<sup>2</sup>, respectively, and a floor to ceiling height of 2.50m (Fig. 1). Table 1 summarizes the design features of the building enclosure.

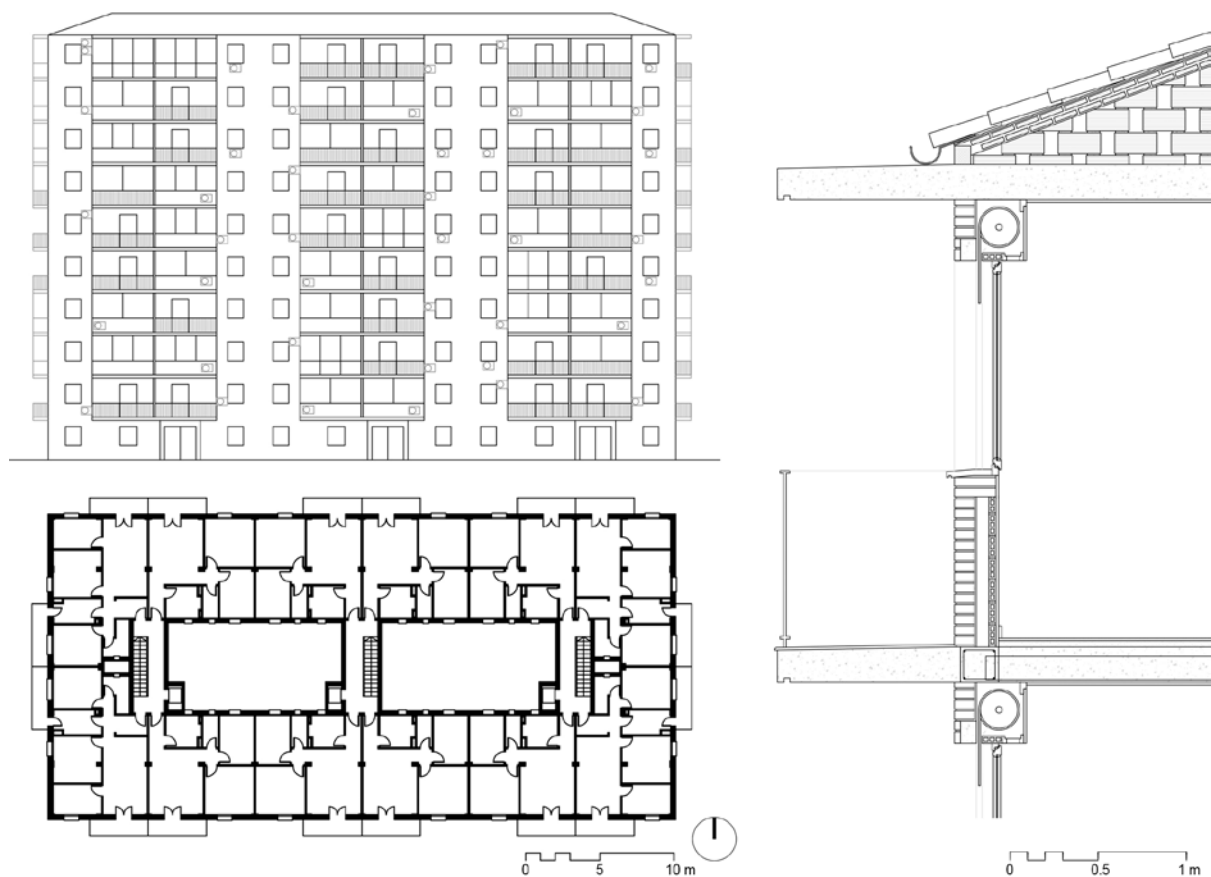

Fig. 1: Layout of the existing building: elevation, floor plan and vertical section of the top floor [2].

	Construction	U-values (W/m <sup>2</sup> K)
<b>Roof</b>	Ceramic tiles, brick board, supported by ventilated brick walls placed every 1m, 200 mm reinforced concrete	1.48
<b>Facade</b>	Brick veneer, air cavity, hollow bricks, gypsum plaster	1.69
<b>Windows</b>	Aluminium without thermal break, 6 mm single glazing	5.7

Table 1: Design features of the building enclosure.

### Definition of retrofitting scenarios

The aim of this case study was to know whether the current retrofitting solutions in Madrid are suitable if the life cycle approach is considered, and if the requirements in housing renovation could be strengthened. Therefore, three scenarios were defined: Business as Usual (BAU) practices (E1), solutions to achieve Spanish Building Regulation for both existing and new buildings (E2A and E2B respectively) and actions to achieve Passive House standard (E3). Table 2 summarizes the requirements for each scenario for the city of Madrid.

	Heating demand* (kWh/m <sup>2</sup> )	Cooling demand* (kWh/m <sup>2</sup> )	Infiltration rate (ac/h)
<b>E1</b>	-	-	-
<b>E2A</b>	36.44	15.66	-
<b>E2B</b>	27.37	15	-
<b>E3</b>	15	15	0.6**

\* Maximum final energy demand; \*\*ac/h at 50 Pa

Table 2: Energy requirements for the retrofitting scenarios proposed.

BAU solutions were defined on the basis of an in-depth case study of the projects financed by the Municipal Housing and Land Company of Madrid (EMVS). It was observed that materials used in housing renovation in Madrid are the same in every building. Therefore, in this research, the additional scenarios were proposed based on these solutions, adapted to the requirements of each scenario (Table 2). To do so, EnergyPlus

	E1	E2A	E2B	E3
<b>Roof</b>	8 cm XPS under tiles	8 cm MW over the last slab	16 cm MW over the last slab	16 cm MW over the last slab
<b>Facade</b>	ETICS. 6 cm EPS	ETICS. 4 cm EPS	ETICS. 12 cm EPS	ETICS 12 cm EPS
<b>Windows</b>	AL(TB) + 4/6/4	AL(TB) + 4/6/4	N: PVC + 8/16/8 Low-E S/E/O: PVC + 4/10/4 Low-E	PVC + 4/10/4 Low-E
<b>Ventilation</b>	Natural ventilation	Natural ventilation	Natural ventilation	Mechanical ventilation + HR

XPS: extruded polystyrene; MW: mineral wool; EPS: expanded polystyrene; AL(TB): aluminium with thermal break; ETICS: External Thermal Insulation System; N: North; E: East; W: West; S: South; HR: heat recovery.

Table 3: Retrofitting solutions for the renovation scenarios proposed.

For the energy calculation, energy savings for heating and cooling compared to the existing building were considered. The systems' efficiencies were 75% for heating production with natural gas and 138.6% for cooling production with electricity.

### Life cycle assessment

Due to the lack of inventory data or Environmental Product Declarations (EPD) in the building sector in Spain, the Ecoinvent life cycle inventory database (version 2.2) was used [5].

[3] was used, considering the usage profile established by the Spanish Building Regulation [4]. Table 3 presents a brief description of the solutions considered in each scenario.

### 2.2 Methodological approach

A multi-criteria methodology was proposed for the comparative assessment of the retrofitting solutions. Life cycle assessment (LCA) and life cycle cost (LCC) methodologies were applied to evaluate environmental impacts and financial costs.

In order to avoid inconsistencies, the goal and scope was defined equally for LCA and LCC. Functional unit was defined as 1 m<sup>2</sup> of heated and cooled net floor area of a single unit in a multifamily apartment block, located in Madrid in 2014. A life span of 50 years was considered.

The scenarios analysed did not differ in the amount of existing materials being demolished, so the materials of the existing building were excluded from the comparative analysis. Only the impacts and costs of the new materials and the reduction in energy consumption due to the ESM were considered. The analysis included the production of the required materials for the renovation, the transport of the materials to the construction site, construction (limited to the material losses during construction), use stage (maintenance, replacements, heating and cooling final energy savings) and the end-of-life (EoL) (limited to the separation of waste, the transport to the EoL treatment plant and the EoL treatment, which included both landfill and recycling).

The life cycle assessment was conducted following the European (CEN) standard. The seven impact categories of the European (CEN) standard on environmental impact of buildings [6] are considered as there is a large consensus on their relevance as well as scientific robustness of the impact assessment models related to them: abiotic depletion potential – non-fossil (ADP-non-fossil); abiotic depletion potential – fossil (ADP-fossil); acidification potential (AP); eutrophication potential (EP); global warming potential (GWP); ozone layer depletion potential (ODP); photochemical ozone creation potential (POCP).

According to the current version of the CEN standard, CML version 4.1 (dated October 2012) was used for the impact assessment.

A multiplicity of individual impact scores is rarely a good basis for decision making. Therefore, a weighting was used by means of monetary valuation. Monetary valuation is an optional evaluation step in LCA. The objective of monetary valuation in the research was to express, in monetary terms, how the welfare of current and future generations is affected by the environmental impacts caused by activities in the building sector. These environmental costs (also referred to as “external costs” or “shadow costs”) arise when the activities of one group of people have an impact on others, and when the first group fails to fully account for these impacts [7]. For each individual environmental indicator, the characterization values are multiplied by a monetization factor (e.g.: X kg CO<sub>2</sub> equivalents times Y €/kg CO<sub>2</sub> equivalents). This factor indicates the cost of the damage to the environment and/or humans for avoiding potential damage or settling any damage incurred [8]. The West-European monetary values from the OVAM:MMG method developed in Belgium were used in our approach [8,9]. For the analysis, the central values of the OVAM:MMG method were used (Table 4). Environmental costs can be then compared/added up with/to the financial costs.

Environmental indicator	Unit	Monetization factor (€/unit)
ADP-non fossil	kg Sb eq	1.56
ADP-fossil	MJ net caloric value	0
AP	kg SO <sub>2</sub> eq	0.43
EP	kg (PO <sub>4</sub> ) <sup>3-</sup> eq	20
GWP	kg CO <sub>2</sub> eq	0.100
ODP	kg CFC-11 eq	49.10
POCP	kg C <sub>2</sub> H <sub>4</sub> eq	0.48

Table 4: Overview of West-European monetary values (central) for CEN indicators, 2014 [9].

#### Life cycle cost

The Net Present Value (NPV) method was adopted for the LCC calculation on the basis of the existing literature. An energy efficient renovation of a building requires an investment cost, but generates savings in the energy consumption over the life span of the building. To be profitable, the energy cost saved by the measure over its use life will need to be greater than the capital investment, cost of maintenance and replacements and EoL cost [10].

The cost of renovation included building material costs, labour costs, indirect costs (which comprise the costs for indirect labour, machinery and tools, temporary facilities, and quality control), fees of architects and 10% VAT. The

cost data was collected from a database valid for the Spanish context, for the year 2014 [11]. The cost of maintenance and replacements consists of the costs of building materials and labour costs. Energy savings are calculated for heating and cooling. A cost of 0.18 €/kWh for electricity and 0.075 €/kWh for natural gas were assumed. Based on a projection of the observed past trend according to the EUROSTAT data and the data from the Spanish Institute of Statistics, a yearly increase of 1.85% was considered for building materials, 0% for labour, 3.5% for natural gas and 5% for electricity. Moreover, a real discount rate of 3% was considered. Finally, the EoL cost includes the cost for the separation of waste, transport to the treatment place and the EoL treatment.

#### Multi-criteria optimization

The Pareto optimization principle was adopted to identify the retrofitting scenarios in order of priority. The preferred solutions are regard as the ones with lower investment cost and higher life cycle savings. Therefore, three objectives were defined for the combination of LCA and LCC:

- Highest life cycle financial savings (LF savings) and lowest financial investment (IF)
- Highest life cycle environmental savings (LE savings) and lowest environmental investment (IE)
- Highest life cycle environmental savings (LE savings) and lowest financial investment (IF)

#### Sensitivity analyses

According to the existing literature [12], sensitivity analyses were performed on the most important uncertain parameters: lifespan, monetary valuation factors, discount rate and growth rate of energy.

### 3 RESULTS AND DISCUSSION

Regarding energy issues, energy demand and demand reduction were assessed. The energy demand for each scenario and energy savings compared to the existing building (E0) are presented in Fig. 2 for heating and cooling. Scenarios E1 and E2A present similar results, which can be explained by the fact that the requirements to get renovation subsidies are similar to the current Spanish Regulation for housing renovation.

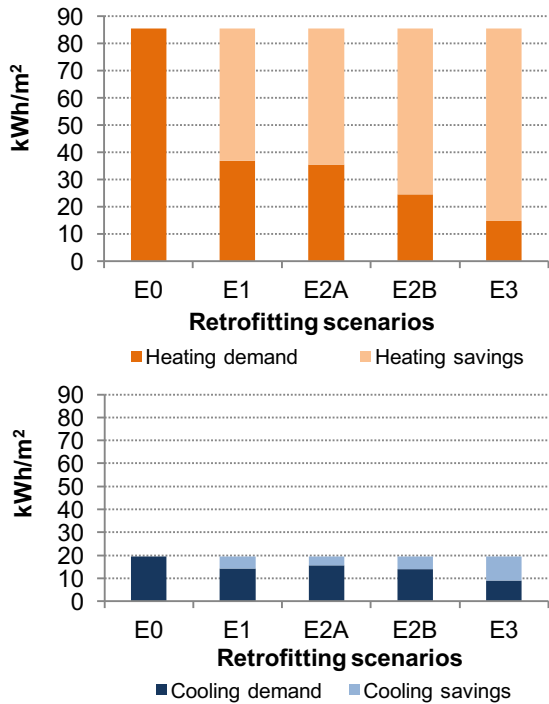

Fig. 2: Net energy demand and energy savings compared with the existing building of retrofitting scenarios for heating and cooling.

In all the retrofitting scenarios the net cooling demand is lower than requested. It was observed that, because of the geometry of the building, the addition of solar protection decreased the cooling demand only 1 kWh/m<sup>2</sup> year, while it increased the heating demand. Therefore, they were not considered in this analysis.

Environmental results are presented in Fig. 3. From the environmental point of view, scenarios E1 and E2A appeared to be unfavourable, as they had higher initial impact than scenario E2B, while life cycle savings are lower.

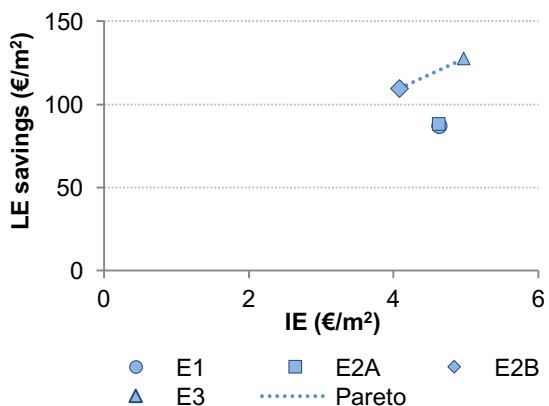

Fig. 3: Environmental assessment, initial environmental cost (IE) vs. life cycle environmental savings (LE savings).

According to the financial results (Fig. 4), all the scenarios are placed in the Pareto front. However, scenarios E1 and E2A are not recommended as LF savings are about 30% lower than the savings of scenario E2B, which

requires only a limited additional investment cost. Moreover, scenario E3 requires higher investment than E2B (30%), while the savings are not high enough (10%).

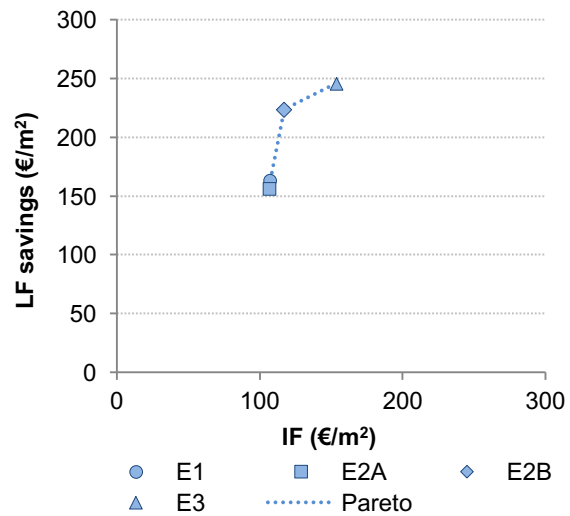

Fig. 4: Economic assessment, initial financial cost (IF) vs. life cycle financial savings (LF savings).

Regarding the objective to achieve the highest LE savings for the lowest IF cost (Fig. 5), E1 is out from the Pareto front. Although it is very similar to scenario E2A, the investment cost is a bit higher, while the LE savings are a bit lower. E3 presents the highest LE savings. However, it is also the most expensive scenario. The investment cost is 30% higher, while the LE savings is only 12% higher.

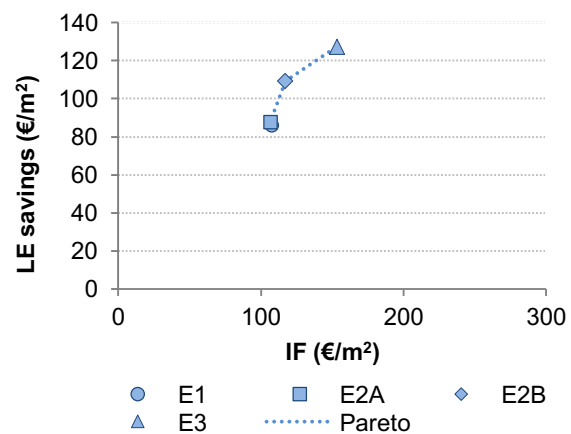

Fig. 5: Initial financial cost (IF) vs. life cycle environmental savings (LE savings).

Sensitivity analyses were made varying the life span of the retrofitting scenarios, the discount rate, the growth rate of energy prices and the monetary values. The same trend was found for all the parameters.

#### 4 CONCLUSIONS

In this paper, a multi-criteria methodology was proposed to assess different retrofitting solutions

from an environmental and financial perspective through the life cycle approach. A representative case study in Madrid was selected to illustrate its applicability.

The results show that, for the building typology analysed, the current retrofitting strategies (scenario E1) are not optimal from an environmental point of view. Moreover, the solutions chosen to fulfil the Spanish Regulation requirements (for housing renovation) were not optimal from an environmental approach either. Although Passive House standard (E3) meets the three objectives proposed, it requires higher investment costs than the achievement of Spanish Building Regulation for new buildings (E2B), due to the heating recovery system, reducing the life cycle financial savings. Therefore, scenario E2B seems to be the most favourable one. Finally, even if the results are specific for this case study, a representative case study was chosen as case study in order for the results to be applicable for other cases with similar building features.

## 5 REFERENCES

- 1 National Housing Institute. Population and Housing census 2011. 2014.
- 2 Pombo, O. et al. Modelo de edificación para el análisis multicriterio de la rehabilitación del parque residencia madrileño de los años 1950-1980, in Architectural research findings: building construction, management, technology. 2014: Madrid, Spain. p. 412–416.
- 3 EnergyPlus. The official building simulation program of the United States Department of Energy. <http://www.eere.energy.gov/buildings/> [accessed 08.05.15].
- 4 Ministerio de Fomento. Código Técnico de la Edificación, Orden FOM/1635/2013, de 10 de septiembre, por la que se actualiza el Documento Básico DB-HE 'Ahorro de Energía', del Código Técnico de la Edificación, aprobado por Real Decreto 314/2006. Spain, 2013.
- 5 Ecoinvent Centre. The ecoinvent version 2.2 database. 2010. Available from: <http://www.ecoinvent.org/database/ecoinvent-version-2/ecoinvent-version-2.html>
- 6 EN 15978:2011. Sustainability of construction works - Assessment of environmental performance of buildings - Calculation method. 2012.
- 7 European Commission. ExternE—Externalities of energy. A research project of the European Commission. 2008. Available from: [www.ExternE.info](http://www.ExternE.info)
- 8 Allacker, K. et al. Environmental Profile of Building elements. 2013, p. 181. Available from: <http://www.ovam.be>
- 9 De Nocker, L. et al. Annex: update monetisation of the MMG method (2014). Mechelen, 2015.
- 10 Gorgolewski, M. Optimising renovation strategies for energy conservation in housing. *Building and Environment*, 1995. 30(4): p. 583–589.
- 11 Colegio Oficial de Aparejadores, Arquitectos Técnicos e Ingenieros de Edificación de Guadalajara. Precios Centro de la construcción. Guadalajara, 2014.
- 12 Pombo, O. et al. The challenge of sustainable building renovation: assessment of current criteria and future outlook. *Journal of Cleaner Production*, 2016. 123: p. 88-100.





## Expanding Boundaries: Systems Thinking for the Built Environment

### BUSINESS CASE STUDY FOR THE ZERO ENERGY REFURBISHMENT OF COMMERCIAL BUILDINGS

A. Greco<sup>1\*</sup>, T. Konstantinou<sup>1</sup>, H.R. Schipper<sup>1</sup>, R. Binnekamp<sup>1</sup>, E. Gerritsen<sup>2</sup>, R. de Graaf<sup>1</sup>, A. van den Dobbelsteen<sup>1</sup>

<sup>1</sup>Delft University of Technology, Postbus 5, 2600 AA, Delft, The Netherlands

<sup>2</sup>Techniplan Adviseurs B.V., Watermanweg 102, 3067 GG, Rotterdam, The Netherlands

\*Corresponding author; e-mail: a.greco@student.tudelft.nl

#### Abstract

Net zero energy is already an ambitious target for several buildings, especially since the DIRECTIVE 2010/31/EU that requires increasing the number of nearly zero energy buildings. The existing commercial building stock needs to be included in order to achieve the 2020 EU environmental targets. The main barriers of zero energy refurbishment of existing nonresidential buildings appear to be financial rather than technical, next to a number of other extrinsic factors that do not stimulate such an investment.

While a business case for new zero energy buildings is believed to exist, controversial opinions can be found with respect to refurbishment of large buildings. The present study aims to identify the factors that affect the feasibility of the zero energy refurbishment of existing commercial buildings, while suggesting ways to create the business case addressing the Dutch market.

Through interviews with real estate investors, the study identified the financial and technical barriers encountered today to undertake deep energy retrofit. Subsequently, the design interventions needed to refurbish a Dutch office building and meeting the net zero energy target were evaluated using a software complying with the Dutch standards NEN 7120. A risk and sensitivity analysis with Monte Carlo simulations showed the influence that design aspects, energy price and landlord-tenant agreements have on the business case.

The study has concluded that a business case considering the energy savings alone is not sufficient to convince investors. However, when the design provides additional benefits, such as increasing the property value, the refurbishment can become feasible. This is an important observation to promote the refurbishment towards a zero energy building stock.

#### Keywords:

Net-zero energy; refurbishment; commercial buildings; economical evaluation; risk analysis; Monte Carlo simulations

## 1 INTRODUCTION

The goal of this research is to identify the barriers for the zero energy refurbishment of Commercial Buildings while suggesting a number of ways to create the business case for it. Across Europe, only 1% of buildings in any given year are newly built [1], about 70% of buildings are over 30 years old and about 35% are more than 50 years old [2]. Given the fact that the building sector is

responsible for about 40% of the total Greenhouse gases (GHG) emission [3], massive refurbishment aiming at improving the performance of existing buildings, seems to remain the most logical way forward. Moreover, considering the new constructions rate, it is not difficult to imagine that most of the buildings present in 2050 have already been built [4]. These buildings are also the ones supposed to require 80% less energy compared to the 2008

levels [5]. Aiming at high standards of energy efficiency, such as zero energy, is essential. Looking at all the European building stock, energy consumption in the commercial sector grows at a higher rate than other sectors (due predominantly to the expansion of HVAC systems). Office and retail are amongst the most energy intensive typologies typically accounting for over 50% of the total energy consumption for nondomestic buildings [3]. This makes the energy retrofit of the commercial building stock a priority.

Although the importance of refurbishing existing commercial buildings is widely recognized, it appears that the current refurbishment rate is insufficient to meet the 2020 EU's energy targets. Both the quality and the scale of refurbishment need to improve. This is why this research addresses the **zero energy** refurbishment, as a way to analyse a high, but soon needed, energy goal. Here the term zero energy refers to a building with zero net energy consumption, meaning the total amount of energy used by the building on an annual basis is roughly equal to the amount of renewable energy created on the site [6]. While the business case for *new* zero energy buildings is believed to exist, controversial opinions can be found in literature concerning the zero energy refurbishment. For new buildings, the business case existence is not discussed mainly because it will be a compulsory practice from the year 2020 [5].

The present study aims at identifying the factors that affect the feasibility of the zero energy refurbishment of existing commercial buildings, while suggesting ways to improve the business case. Through interviews to real estate investors, the study identified the financial and technical barriers encountered today to undertake deep energy retrofit. Subsequently, the design interventions needed to refurbish a Dutch office building and meeting the net zero energy target were evaluated using a software complying with the Dutch standards NEN 7120. A risk and sensitivity analysis with Monte Carlo simulations showed the influence that design aspects, energy price and landlord-tenant agreements have on the business case.

## 2 METHODOLOGY

In order to identify the main barriers for the zero energy refurbishment of commercial buildings and to suggest ways to create the business case, this research was structured as follow:

- (i) Interviewing relevant actors in the decision making phase
- (ii) Evaluating the business case for a ZE refurbishment case study design
- (iii) Performing a risk and sensitivity analysis to identify the most influential variables for creating the business case

Below, the methodology adopted for every step is briefly explained.

### 2.1 Interviews

For the scope of this research a *general interview guide approach* [7] is chosen. A list of questions was prepared but only used as outline to assure covering the intended topics. Barriers, opportunities and drivers of the zero energy refurbishment were discussed.

In total, 9 interviews are shown in the result section, reporting at least one interviewee per the following categories:

- Investors
- Designers
- Real Estate Experts
- Energy Service Companies (ESCOs')
- Tenants

### 2.2 Business Case Analysis

The Zero Energy refurbishment was designed for De Groene Toren, an office building from the 1980s in The Hague, the Netherlands, already refurbished in 2011. The building occupies a gross floor area of approximately 35,000 m<sup>2</sup>.

The software ENORM was used to identify the interventions needed to reach the zero energy target, as it allows carrying energy calculation according to the Dutch regulation NEN 7120 (The NEN 7120 specifies terms, definitions and methodologies for the determination of the energy performance.).

Firstly, the costs of the renovation are estimated, together with the cost of maintenance, comparing the ones occurring before and after the renovation. The costs were estimated by consulting a cost database [8] and contractors. Secondly, the sources of revenues such as increase of rent, change of rentable space, and maintenance cost savings are calculated. Subsequently, the return of investment is determined and expressed in terms of economic indicators such as *Net Present Value (NPV)*, *Internal Rate of Return (IRR)* and *Payback Time*. The NPV and IRR are calculated over a 25-year period time, being this a time after which a building usually needs refurbishment.

### 2.3 Risk and Sensitivity Analysis

The risks analysis is performed to deal with the uncertainties and errors of the business case evaluation. For instance, costs may vary considerably depending on the contractor consulted for the estimation or on the specific supply choice. The sensitivity analysis is done to identify variables that most affect the business case. A **Monte Carlo Simulation (MCS)** was performed, achieving the intended overview of the parameters that play the most important role compared to others in defining the business case. The MCS is a probabilistic method that can overcome uncertainties or mistakes in the

analysis when a 'safe' range of variables is used as input. To perform the simulation, the Excel application Oracle Crystal Ball [9] was used. By defining variable inputs in terms of realistic range of possible values, Crystal Ball generates thousands of calculations, each time using a different randomly selected value. In this case a beta-PERT distribution was chosen which allows giving a minimum, most likely and maximum value. Changing the forecasted variables, the probability of the IRR to be greater than 10% is given, together with the probability of the NPV to be greater than 0 and of the Payback time to be less than 15 years.

## 2.4 Strategies

To analyse the influence and the weight that each parameter has on the business case (with the MCS), four different strategies were defined:

- Base-Case (A)
- Budget allocation (B)
- Increase of rentable space (C)
- Combination (D)

All the strategies describe a renovation consisting of the minimum interventions needed to reach zero energy with a rent within the market range (from 150 to 200 €/m<sup>2</sup>) for that specific location.

Table 1 summarizes the assumptions made for each strategy.

	A	B	C	D
Increase of floor area with the renovation			✓	✓
Owner does not pay for energy bills	✓		✓	
Energy budget allocation to tenant, owner officially pays for energy		✓		✓

Table 1: Assumptions for strategy A, B, C, and D.

## 3 RESULTS

### 3.1 Interviews

The results of the interview are summarized in Table 2. The main barriers for the business case of the zero energy refurbishment of commercial buildings appear to be financial rather than technical. In particular, the increase of value of refurbished zero energy building is considered to be too low. Lack of financial attractiveness seems to be the main reason why zero energy refurbishment does not belong to the current practice.

### 3.2 Business Case Evaluation

For the chosen building the refurbishment designed to reach the zero energy target includes measures such as the addition of a geothermal heat pump, the replacement of all the existing light bulbs with LED lights and mechanical demand-controlled ventilation (CO<sub>2</sub> control).

Interventions on the building envelope were also necessary, replacing the existing elements with triple insulated glazing (U value of 0.25 W/m<sup>2</sup>K) and with insulated façade panels (R<sub>c</sub> value of 7 m<sup>2</sup>K/W). Concerning the energy production, PV cells are placed on the roof (1400 m<sup>2</sup>) and on the Southeast and Southwest façades (2386 and 1481 m<sup>2</sup>, respectively).

With these energy measures, the energy demand of the building is 2.5 mln MJ. In order to fully achieve zero energy an additional 3120 m<sup>2</sup> of PV panels need to be installed off-site.

The total renovation was estimated to cost about 12 mln €, with a Payback time of 18 years and a NPV equal to 3.27 mln €.

### 3.3 Risk and Sensitivity Analysis

Table 3 shows the range used as input for the MCS while Table 4 summarizes the outcomes for each strategy. It can be seen that the probability for the NPV to be positive goes from 39.6% with the base case strategy (A) to 90.9% with the combination strategy (D). The sensitivity analysis for the NPV is shown from Figure 1 to Figure 4.

## 4 DISCUSSION

In commercial buildings it is usually the tenant who pays for energy bills and the owner who pays for the refurbishment. This reality brings to a paradox: the owner invests in energy saving measures while the tenant benefits from them. The only way for the owner to get back the investment would be increasing the rent, which is not always possible. Rental increase depends on location and other parameters, and has market rules to follow. To remove the paradox and improve the business case, the budget allocation strategy was made: the tenant pays a quota that is equal or smaller than the previous energy bill, which is added to the competitive market rent.

The owner officially pays for energy, but with zero energy buildings the only energy to be paid is for backup system (lack of renewable energy supply) and grid connection.

Should the tenant demand too much energy, he would need to pay for it. Such a measure seems to offer a win-win situation for tenant and owner solving the typical user-behaviour problem of all-inclusive contracts.

Zero Energy Refurbishment				
Category	Interviewee's role	Main Drivers	Opportunities	Barriers
Investor	Senior Real Estate Development (BREEVAST)	<ul style="list-style-type: none"> <li>Strategic location</li> <li>Local regulation</li> <li>Local incentives</li> </ul>	<ul style="list-style-type: none"> <li>Certification seen as added value for property evaluation</li> </ul>	<ul style="list-style-type: none"> <li>Inefficient certification systems in The Netherlands</li> <li>Lack of sustainable mind-set and knowledge by building owners</li> <li>Attractive new building options</li> <li>Lobbying of current providers</li> <li>Economic crisis</li> </ul>
	Owner (DTZ Zadelhoff)	<ul style="list-style-type: none"> <li>Strategic location</li> <li>Tenants' requests</li> <li>Local incentives</li> <li>Age of the building</li> </ul>	<ul style="list-style-type: none"> <li>Market increase in the coming years</li> </ul>	<ul style="list-style-type: none"> <li>Balance between investment and return</li> </ul>
	Technical Project Manager Offices (CBRE Global Investors)	<ul style="list-style-type: none"> <li>Strategic location</li> <li>Tenants' requests and alternatives</li> <li>Vacancy rate</li> <li>Return of investment</li> </ul>	<ul style="list-style-type: none"> <li>Increasing rent-ability</li> <li>Decreasing vacancy</li> <li>Corporate image</li> </ul>	<ul style="list-style-type: none"> <li>Non-existing economical technical solutions</li> <li>Bureaucracy of external renewable sources</li> </ul>
Designer	Sustainability and Life Cycle Performance Engineer (RHDHV)	<ul style="list-style-type: none"> <li>Location</li> <li>Budget</li> <li>Life cycle costs</li> <li>Type of contract</li> </ul>	<ul style="list-style-type: none"> <li>Technological Improvements</li> <li>NZEB technically possible</li> </ul>	<ul style="list-style-type: none"> <li>Impossibility to predict the real energy demand</li> <li>Significant uncertainties of users' behaviour</li> <li>Investors are not enough interested in energy</li> </ul>
	Sustainability and Innovation Engineer (Techniplan Adviseurs)	<ul style="list-style-type: none"> <li>Business case</li> <li>Current building performance</li> <li>Technical Life Cycle of building services</li> <li>User requirements</li> </ul>	<ul style="list-style-type: none"> <li>Technological Improvements</li> <li>BIM for building management</li> </ul>	<ul style="list-style-type: none"> <li>Research phase more risky and costly</li> <li>Uncertainty of existing building data and modelling</li> </ul>
Real Estate Expert	Assistant Professor Real Estate Finance (TU Delft)	<ul style="list-style-type: none"> <li>Increase of property value (IRR, NPV)</li> <li>Decrease of vacancy rate</li> <li>Depreciation</li> </ul>	<ul style="list-style-type: none"> <li>Not discussed</li> </ul>	<ul style="list-style-type: none"> <li>Uncertainty of return of Investment</li> <li>Economic crisis</li> </ul>
	Assistant Professor Real Estate & Housing (TU Delft)	<ul style="list-style-type: none"> <li>Rental market</li> <li>Location</li> <li>Adaptability of the building architecture</li> <li>Tenants requests</li> <li>Building importance</li> </ul>	<ul style="list-style-type: none"> <li>Increasing corporate image</li> </ul>	<ul style="list-style-type: none"> <li>Current refurbishment to meet lower energy labels</li> <li>Initial costs too high</li> </ul>
ESCO	Product Manager (ENECO)	<ul style="list-style-type: none"> <li>Technological innovation</li> <li>Regulations</li> </ul>	<ul style="list-style-type: none"> <li>New business</li> </ul>	<ul style="list-style-type: none"> <li>Non-Intelligent Appliances</li> <li>Complex systems to be developed</li> <li>Absence of business case</li> </ul>
Tenant	Facility Manager (PostNL)	<ul style="list-style-type: none"> <li>Energy Savings</li> <li>Corporate Image</li> </ul>	<ul style="list-style-type: none"> <li>Not tangible opportunities could be identified</li> </ul>	<ul style="list-style-type: none"> <li>Too high investment</li> <li>Technical impossibilities</li> </ul>

Table 2: Summary of the outcome of the interviews.

Variable	Low	Mid	High	Unit	Source
CAPEX *)	12,000,000	17,000,000	22,000,000	€	Database and contractors
OPEX **)	30,000	65,000	100,000	€	Database and contractors
Rent after renovation	150	175	200	€/m <sup>2</sup>	DTZ
Occupancy rate after renovation	50	75	100	%	DTZ
Total surface before renovation	30,000			m <sup>2</sup>	Building
Total surface after renovation	30,000	32,000	34,000	m <sup>2</sup>	Design strategies
Electricity price	0.05	0.15	0.25	€/kWh	EUROSTAT
Gas price	0.20	0.40	0.60	€/m <sup>3</sup>	EUROSTAT
OPEX savings after renovation	0	7,500	15,000	€	Database and contractors
Discount rate	2	4	6	%	Interviews
Inflation rate	0	1	2	%	EUROSTAT
Annual rent increase	1	2	3	%	Interviews
Building value increase	5	8	11	%	Evaluator

\*) Capital Expenditures \*\*) Operational Expenditures

Table 3: Variables and related ranges used for the Monte Carlo simulation.

A common argument against the business case for energy retrofit is that the energy price is too low. Assuming the owner would take advantage from an improved energy performance, looking at the budget allocation strategy, the business case does improve, suggesting that higher energy prices favour energy refurbishment. Nonetheless, looking at Fig. 1 to Fig. 4, the electricity and gas prices are never in the top 3 influencing variables. Other parameters such as the Capital Expenditures (CAPEX), the increase of rent after renovation and the occupancy rate play a much more important role in determining the business case.

	A	B	C	D
IRR>10% [%]	4.23	23.5	22.0	53.2
NPV>0 [%]	31.6	69.7	65.0	90.9
Payback<15 y [%]	6.34	30.6	27.7	61.1

Table 4: Probability of economic indicators for different strategies of the MCS.

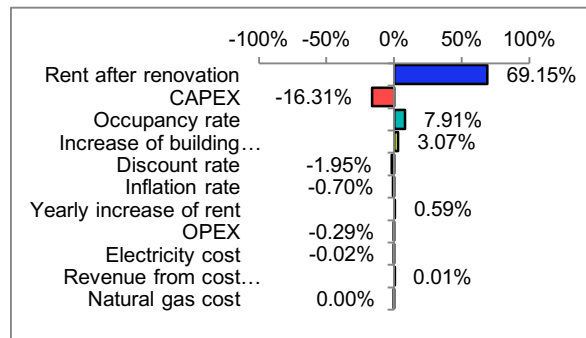

Fig. 1: Sensitivity for the NPV for the base case strategy (A).

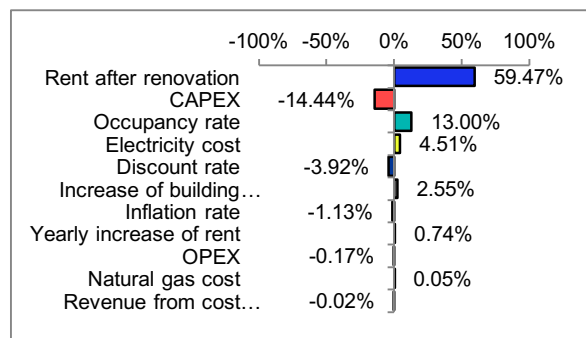

Fig. 2: Sensitivity for the NPV for the budget allocation strategy (B).

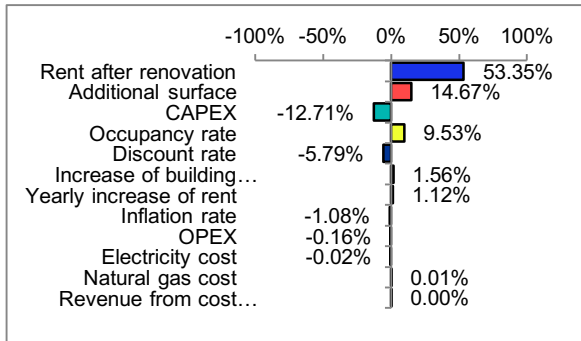

Fig. 3: Sensitivity for the NPV for the increase of rental space strategy (C).

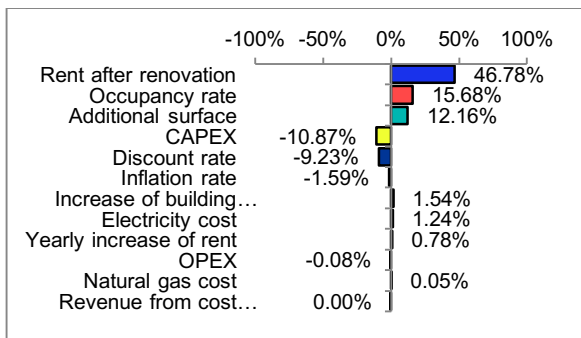

Fig. 4: Sensitivity for the NPV for the combination strategy (D).

## 5 CONCLUSIONS

This study concludes that when the design provides additional benefits, such as increasing the property value, the refurbishment can become feasible. The most relevant conclusions reached with this research are:

- Interviewing stakeholders provided a direct overview of barriers and opportunities of the ZE refurbishment.
- Investors agree that the barriers for the zero energy refurbishment of commercial buildings are financial: the value increase of the building after renovation is not high enough with respect to the initial investment required (CAPEX).
- The evaluation of the business case by means of Monte Carlo simulations allows overcoming uncertainties in the input variables and identifying the most influencing ones.
- As long as the owner pays for energy retrofit and tenant pays for energy bills the energy performance does not influence the business case. This way the energy price and energy savings do not impact the business case.

Allocating a budget for energy to the tenant can easily improve the business case for the owner who invests in energy retrofit, while helping to control the user behaviour.

- Adding surface with the refurbishment increases the rentable space hence increases the revenue and improves the business case.

The model used for this study could be tested on more existing buildings to decide if a ZE refurbishment would present a good business case. It could also be used for assessing already refurbished buildings for which a lower energy target was chosen.

## 6 REFERENCES

1. F. Meijer, L. Itard, M. Sunikka-Blank, Comparing European residential building stocks: performance, renovation and policy opportunities, *BUILDING RESEARCH & INFORMATION*, 2009, vol. 37(5-6), p. 533–551.
  2. B. Poel, G. Van Cruchten, C.A. Balaras, Energy Performance Assessment of Existing Dwellings & Non Residential Buildings, *Energy and Buildings* 39, 2007, p. 393–403.
  3. L. Pérez-Lombard, J. Ortiz, C. Pout, A review on buildings energy consumption information *Energy Build*, 40 (3) (2008), p. 394–398
  4. F. Pacheco Torgal, M. Mistretta Artkras Kaklauskas, C. G. Granqvist, L. F. Cabeza, Nearly Zero Energy Building Refurbishment, A Multidisciplinary Approach. 2013 Springer London.
- Reports:
5. European Commission, Energy 2020: A strategy for competitive, sustainable and secure energy. 2010, Communication From The Commission To The European Parliament, The Council, The European Economic And Social Committee and the Committee of The Regions.
  6. P. Torcellini, S. Pless, M. Deru, Zero Energy Buildings: A Critical Look at the Definition, 2006, U.S. Department of Energy. National Renewable Energy Laboratory report.
  7. M. D. Gall, W. R. Borg, J. P. Gall, Educational Research: An Introduction, 2003.
  8. Bouwkosten, online database, available at: <http://www.bouwkosten.nl/>
  9. Oracle, Crystal Ball, Release 2.4, 2011 for Microsoft Office.



## Expanding Boundaries: Systems Thinking for the Built Environment

### IMPACT OF BUILDING REFURBISHMENT STRATEGIES ON THE ENERGETIC PAYBACK

A. Passer<sup>1\*</sup>, C. Ouellet-Plamondon<sup>2</sup>, P. Keneally<sup>3</sup>, G. Habert<sup>3</sup>

<sup>1</sup> Institute of Technology and Testing of Building Materials, Graz University of Technology, Inffeldgasse 24, 8010 Graz, Austria

<sup>2</sup> École de Technologie Supérieure (ETS), 1100, Notre-Dame West, Montreal, Quebec, H3C 1K3, Canada

<sup>3</sup> Institute of Construction and Infrastructure Management, ETH Zürich, Stefano-Francini-Platz 5, 8093 Zürich, Switzerland

\*Corresponding author; e-mail: alexander.passer@tugraz.at

#### Abstract

The target of the International Energy Agency (IEA) and the European Commission (EC) is to achieve a reduction of 80% for global greenhouse gas (GHG) emissions by 2050. Buildings account worldwide for 40% of global energy consumption and 30% of GHG emission. Due to the fact that the building stock plays a key role in achieving these targets, the aim of the paper is to find an optimal refurbishment strategy in terms of lowest environmental impact through life cycle assessment (LCA). Three façade refurbishment scenarios (none, minimum and energetic high quality) and onsite energy generation (solar thermal and photovoltaic panel (PV)) were evaluated. We applied and verified the proposed approach on a residential case study as reference refurbishment project built in the 1960s. The environmental indicators cumulative energy demand, global warming potential and ecological scarcity were evaluated for the LCA covering all life cycle stages over a reference study period of 60 years. The results showed that the optimal refurbishment scenario from an LCA perspective was a high-quality refurbishment of the thermal envelope by the use of prefabricated façade elements, solar thermal collectors as also photovoltaic panels. In terms of the assessed environmental indicators, this refurbishment scenario will always be beneficial due to its lowest impact throughout the life cycle. However, the sensitivity analysis on the high-quality refurbishment strategies determined that a surplus of electricity production by increasing the PV area is not always feasible as the operational impact burdens react with great sensitivity to changes in the electricity mix towards more renewable resources, likely to occur in the near future. It is thus necessary to find an optimum balance between diminishing returns over time and financial investment over the entire life cycles of buildings, especially for plus-energy buildings.

#### Keywords:

Energetic payback; refurbishment strategies; life cycle assessment; prefabricated façade elements

#### 1 INTRODUCTION

The target of the International Energy Agency (IEA) is to achieve a reduction of 80% for global emissions by 2050. Buildings account worldwide for 40% of the global energy consumption and 30% of GHG emission. In Europe, the EU Parliament approved the recast of the energy

performance of buildings directive in 2010 calling on member states to propose measures for increasing the number of close to zero-energy buildings and encouraging best practices in the context of the cost-effective transformation of existing buildings into nearly zero-energy buildings [5].

In Europe, many buildings erected between 1950 and 1980 are now targeted for refurbishment due to their bad energetic performance. If these refurbishments achieve a high level of energy performance, or even reach a plus-energy standard, they would represent a major step towards achieving the European 2020 targets[4].

The three main strategies of building refurbishment are: 1) heating demand reduction (e.g. insulation of the building envelope), 2) energy efficient equipment and low energy technologies and 3) renewable energy supply. The different energetic approaches of the use phase can be classified as follows: low-energy buildings are designed to minimize the operating energy [13]. Passive houses are low-energy buildings that use passive technology (very low heating demand that is to be covered by controlled ventilation with air heating) [9]. Net zero energy buildings (nZEB) are required to have an overall balance between the energy needs and excess from onsite renewable energy and energy imported from the grid [1]. Plus energy buildings should be able to deliver more energy to the grid than they consume [14].

In this paper the successful refurbishment of the lead project “e80<sup>3</sup>-Buildings” (<http://www.hausderzukunft.at/results.html/id5836>) - concepts towards energy plus house standard with prefabricated active roof and facade elements, integrated technical systems and energy network integration - of the research program “house of tomorrow – plus” serves as case study to evaluate different refurbishment strategies. More detailed results can be found in [11]. The lowest environmental impact through LCA will then define the optimum refurbishment strategy.

## 2 METHOD

Based on a case study, different refurbishment strategies are compared by means of LCA for a reference study period of 60 years. The methods applied in this paper rely on to the European Standards EN 15978 [3] for the assessment of the environmental performance of buildings based on the methodology of life cycle assessment (LCA) [2]. By combining the different refurbishment strategies with energy support the issue of the sensitivity with which the impact of a refurbishment strategy reacts to a change in the system is addressed.

### 2.1 Life cycle assessment

The functional unit for the LCA is 1 m<sup>2</sup> of energy reference area per 1 year of the building's lifetime. All results of the life cycle impact assessment (LCIA) are referring to this functional unit. The modelling of the inputs and outputs based on the proposed real construction measures for the study has been carried out

utilizing the professional software (SimaPro version 7.3.3) with the included database Ecoinvent version 2.2 [6]. The different refurbishment scenarios have been modelled in accordance with the methodological approach of EN 15978, as described in [10]. Consequently, only materials, which are replaced or added to the building structure plus transportation task inputs and the operational energy for the building, are assessed. The building elements that are assessed include external walls and roof (only refurbished parts considered), new doors, windows and technical system installations (ventilation, heating, sanitary equipment, electrical equipment). In the case of all these building materials, we assumed a simple final disposal after their deconstruction, and have thus not gone into a consideration here of any potential recycling scenarios. The existing structure and preparatory work inputs were not included in the calculations, owing to the fact that the impact of the refurbishment was exclusively investigated.

The LCIA focuses on the non-renewable share of the cumulative energy demand (CED), the GHG emissions based on the impact indicator global warming potential (GWP) for a time horizon of 100 years for the emissions and the Ecological Scarcity 2006 (UBP) [7].

### 2.2 Refurbishment scenarios

A residential building erected in 1961 and refurbished in 2013-2015 to a plus energy building (see Fig. 1)) served as a case study. This four-story building was constructed using prefabricated sandwich concrete elements without any additional thermal insulation. The insulation of the basement ceiling was approximately 60 mm polystyrene and the ceiling of the unheated attic was with 50 mm wood wool panels. The old roof was a pitched roof with no insulation. The existing windows were double glazed windows with a U-value of 2.5 W/m<sup>2</sup>K and no mechanical ventilation system was installed (Table 1).



Fig. 1: The case study building (left side after and right side before refurbishment).

Five strategies of onsite energy generation for heating and hot water and three refurbishment strategies were modelled for the refurbishments in the case study. A “scenario – matrix codex” was developed to make the comparison possible. In this the first digit represents the energy generation options (A, B, C, D), energy supply (a



or b) and the second digit presents the refurbishment strategies (I, II, III), see Table 2.

The first scenario (I “No refurbishment”) tests the environmental impact on the building when retained, as it exists today. By renewing some parts of the façade, the building was kept habitable in terms of health and wellbeing for users as well as improving the structural envelope to some extent.

The second scenario (II “Minimum refurbishment”) fits a minimum requirement of the thermal envelope of buildings after refurbishment in order to improve the efficiency in terms of isolation and energy performance. Within this minimum refurbishment, it is also assumed that the technical systems for heating will be replaced with gas central heating and/or district heating.

In the third scenario (III “High quality refurbishment”), the existing building will be refurbished into a plus energy building. The high-quality refurbishment concept is based on efficiency measures (highly insulated, prefabricated active energy roof (PV and solar thermal) and energy façade elements with integrated building services - mechanical ventilation with heat recovery (85%), on a high percentage of renewable energy sources as well as a smart integration of energy supply towards heat and electricity networks.

Table 1 gives an overview of the different U-values of the proposed construction measures.

Building element	Refurbishment scenario			High quality
	I None	II Minimum	III	
	U-value [W/m <sup>2</sup> K]			
External wall	0.87	0.31	0.14	
Window	2.50	1.33	1.00	
Top floor ceiling	0.74	0.19	0.10	
Basement ceiling	0.39	0.39	0.30	

Table 1: The U-values used in each of the three scenarios.

For the technical systems we assessed the base case (scenario A), installation of solar thermal area (B), PV area (C), solar thermal area + PV area (B+C) and solar thermal area + increased PV area (D).

Refurbishment scenario	Code	Scenario energy supply
I: No refurbishment	A: Basis	100% Gas
	Aa: Worst case energy supply	50% Coal + 50% Oil
	Ab: Change to district heating	54% District heat + 46% Gas
II: Minimum refurbishment	A: Basis	54% District heat + 46% Gas
	Aa: Worst case energy supply	100% Gas
III: High quality refurbishment	B+C: Basis	54% District heat + 46% Gas
	B+Ca: Worst case energy supply	100% Gas
All scenarios	B: Solar thermal area	
	C: PV area	
	B+C: Solar thermal area + PV area	
	D: Solar thermal area (B) + increased PV area	

Note: A: Conventional energy supply; B: Solar thermal area; C: PV area; B+C: Solar thermal area

Table 2: The change in energy supply scenario encoding matrix.

Within the scenario evaluation the refurbishment options (I, II and III) of the building envelope are then combined with the technical systems (A, B, C and D). The large roof on top of the building and southern orientated façade enables provision of a large area for active modules such as solar thermal collectors and photovoltaics, which will produce either a large proportion or all of the energy requirements for the users.

## 3 RESULTS AND DISCUSSION

### 3.1 Scenario comparison

The results for all refurbishment scenarios are presented in Figure 2. For a better comparison, the results are presented relative to the worst case (scenario I-Aa), which is 100% from non-renewable sources. The results show the trade-offs of the different construction measures in combination with the different technical systems and energy supply. Due to the additional embodied impacts, the high quality refurbishment scenario III B+C is nearly equal to the minimum refurbishment scenario II B+C for the indicators CED n. ren and GWP. The higher impacts in ecological scarcity are driven by the higher weight of embodied impacts.

It can also be observed that the no refurbishment scenario with the installation of solar and PV (I B+C) nearly reaches the minimum scenario based on the worst case (II Aa). In any case, scenario III D shows the lowest life cycle induced impacts overall, mainly due to the energy savings (energy payback) in the use phase.

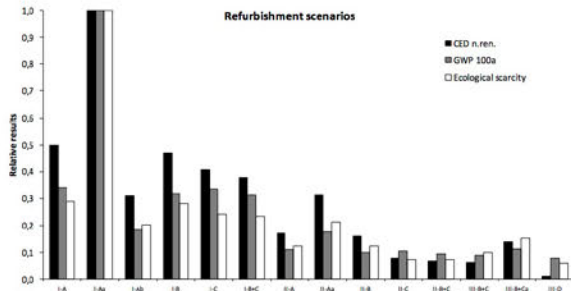

Fig. 2: Relative indicator for the refurbishment scenarios and the energy strategies.

### 3.2 Energetic payback

As plus energy buildings produce more energy than they consume on a yearly primary energy base, the refurbishment scenarios were evaluated in terms of embodied vs operational energy aspects. The concept of the energetic payback time (PBT) [8], [12] was calculated as the ratio of the embodied energy (blue boxes) over the delivered energy (red and yellow box) as pictured in figure 3.

The comparison of the different refurbishment scenarios by analysing the energy payback time is evaluated in relationship to the existing situation (scenario I-A) (see Figure 4). The distance to an intersection point along the time axis indicates the payback time of the scenario with lower impact after intersection in comparison to another scenario. The impact of each refurbishment scenario (including I-A) is an ongoing summarisation over time according to its building stage phases and there is no energy payback.

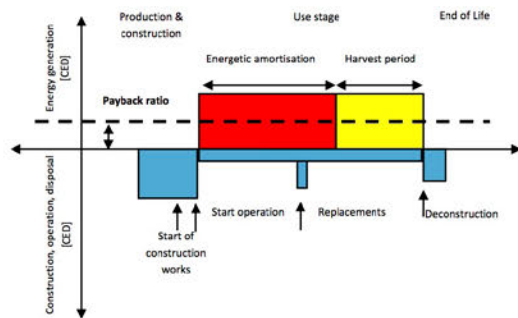

Fig. 3: Concept of the energy payback time [15].

The scenarios II-B+C and III-B+C reach a similar value of overall impact after 25 years. The scenario III-D, with increased photovoltaic area, is the only scenario with an energy payback. It is the best option even reaching “negative impacts” during the operational benefits after 30 years.

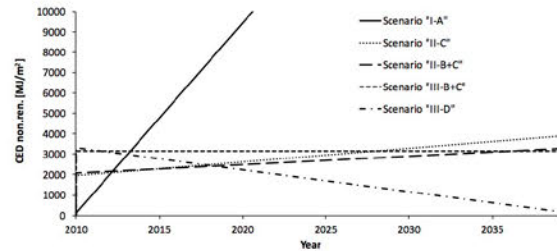

Fig. 4: CED n. ren. payback times of selected cases.

All of the refurbishment scenarios have a very low payback time in relationship with the impact of the existing building (black continuous line in Figure 4), whereas the scenarios of the minimum refurbishment (II) would pay-off after 2 years, the high- quality scenarios (III) would require an extra year due to their additional embodied energy. In addition to the environmental payback, the economic payback of refurbishment is one of the crucial issues, which needs to be further evaluated.

## 4 CONCLUSION

Based on our methodological approach, the optimal refurbishment scenario is a high-quality refurbishment of the thermal envelope by the use of prefabricated façade elements and solar thermal collectors as well as PV modules. In terms of environmental indicators, this refurbishment will always be beneficial due to its lowest environmental impact from a life cycle perspective. In addition, a change of energy supply to district heating proved to be very beneficial for all construction standards and should therefore be implemented rapidly at least as a first and a relatively easy step to implement.

Additionally, the sensitivity analysis on the high-quality refurbishment scenario determined that a surplus of electricity production by increase of PV area is not always feasible as the predicted operational benefits react sensitively to a change of the future electricity mix to more renewable resources. The benefits from delivering energy to the grid and future grid and climate change scenarios needs to be further investigated. It seems to advisable to evaluate this using a consequential LCA approach.

It is therefore necessary to find the optimum balance between diminishing returns due to the changes in energy mixes and financial investment and embodied impacts over the entire lifetime of the building and this especially in the case of plus-energy buildings.

As there is a great and pressing need for the refurbishment of a large share of the building stock due to the large consumption of energy, another major advantage to be achieved here is the reduction of construction time due to the introduction of a high degree of prefabrication as

shown in our case study. In addition, the façade elements are designed in order to ensure a minimal disturbance of the inhabitants during the construction and replacement phase.

## 5 ACKNOWLEDGMENTS

The Authors wish to thank Dr. Karl Höfler from AEE INTEC for the excellent collaboration as lead project manager from the research project e80<sup>3</sup>-Buildings <http://www.hausderzukunft.at> which serves as basis for the case study in this paper, published in [11]. The project was funded by the Federal State of Styria and the programme “Building of Tomorrow” of the Austrian Federal Ministry of Transport Innovation and Technology (BMVIT) via the Austrian Research Promotion Agency (FFG). The Authors greatly appreciate the support given by ETH Zurich (Chair of Sustainable Construction), which made the collaboration for work on this paper possible.

## 6 REFERENCES

1. BERGGREN, BJÖRN ; HALL, MONIKA ; WALL, MARIA: LCE analysis of buildings – Taking the step towards Net Zero Energy Buildings. In: *Energy and Buildings* Bd. 62, Elsevier B.V. (2013), S. 381–391 — ISBN 0378-7788
2. CEN: ÖNORM EN ISO 14040 Environmental management - Life cycle assessment - Principles and framework Bd. 2006 (2006)
3. CEN: ÖNORM EN 15978:2012-10-01-*Nachhaltigkeit von Bauwerken - Bewertung der umweltbezogenen Qualität von Gebäuden - Berechnungsmethode*, 2012
4. D'AGOSTINO, DELIA: Assessment of the progress towards the establishment of definitions of Nearly Zero Energy Buildings (nZEBs) in European Member States. In: *Journal of Building Engineering* Bd. 1 (2015), S. 20–32
5. EC: *Directive 2010/31/EU of the European Parliament and of the Council of 19 May 2010 on the energy performance of buildings*, 2010
6. FRISCHKNECHT, ROLFJUNGBLUTH, NIELS ; ALTHAUS, HANS-JÖRG ; DOKA, GABOR ; DONES, ROBERTO ; HECK, THOMAS ; HELLWEG, STEFANIE ; HISCHIER, ROLAND ; NEMECEK, THOMAS ; REBITZER, GERALD ; U. A.: *Overview and Methodology Data v2.0 (2007)*, 2007
7. HISCHIER, ROLAND ; WEIDEMA, BO ; ALTHAUS, HANS-JÖRG ; BAUER, CHRISTIAN ; DOKA, GABOR ; DONES, ROBERTO ; FRISCHKNECHT, ROLF ; HELLWEG, STEFANIE ; HUMBERT, SÉBASTIEN ; U. A.: *Implementation of Life Cycle Impact Assessment Methods Data v2.2 (2010)*, 2010
8. LÜTZKENDORF, THOMAS ; FOLIENSTE, GREG ; BALOUKTSI, MARIA ; WIBERG, AOIFE HOULIHAN: Net-zero buildings: incorporating embodied impacts. In: *Building Research & Information* Bd. 43 (2015), Nr. 1, S. 62–81. — DOI:10.1080/09613218.2014.935575 — ISBN 09613218 (ISSN)
9. MÜLLER, LIANA ; BERKER, THOMAS: Passive House at the crossroads: The past and the present of a voluntary standard that managed to bridge the energy efficiency gap. In: *Energy Policy* Bd. 60 (2013), S. 586–593
10. PASSER, ALEXANDER ; KREINER, HELMUTH ; MAYDL, PETER: Assessment of the environmental performance of buildings: A critical evaluation of the influence of technical building equipment on residential buildings. In: *The International Journal of Life Cycle Assessment* Bd. 17 (2012), Nr. 9, S. 1116–1130
11. PASSER, ALEXANDER ; OUELLET-PLAMONDON, CLAUDIANE ; KENNEALLY, PATRICK ; JOHN, VIOLA ; HABERT, GUILLAUME: The impact of future scenarios on building refurbishment strategies towards plus energy buildings. In: *Energy and Buildings* (2016)
12. PENG, JINQING ; LU, LIN ; YANG, HONGXING: Review on life cycle assessment of energy payback and greenhouse gas emission of solar photovoltaic systems. In: *Renewable and Sustainable Energy Reviews* Bd. 19, Elsevier (2013), S. 255–274
13. SARTORI, I. ; HESTNES, A.G.: Energy use in the life cycle of conventional and low-energy buildings: A review article. In: *Energy and Buildings* Bd. 39 (2007), Nr. 3, S. 249–257
14. SARTORI, IGOR ; NAPOLITANO, ASSUNTA ; VOSS, KARSTEN: Net zero energy buildings: A consistent definition framework. In: *Energy and Buildings* Bd. 48 (2012), S. 220–232
15. WALL, J ; PASSER, A: Harvesting factor in hydropower generation. In: *Life-Cycle and Sustainability of Civil Infrastructure Systems*: TAYLOR and FRANCIS GROUP, 2013 — ISBN 9780415621267, S. 2419–2426





## Expanding Boundaries: Systems Thinking for the Built Environment

### ECONOMIC AND ENVIRONMENTAL ASSESSMENT OF BUILDING RENOVATION: APPLICATION TO RESIDENTIAL BUILDINGS HEATED WITH ELECTRICITY IN SWITZERLAND

B. Périsset<sup>1</sup>, S. Lasvaux<sup>1\*</sup>, C. Hildbrand<sup>1</sup>, D. Favre<sup>1</sup>, S. Citherlet<sup>1</sup>

<sup>1</sup> University of Applied Sciences of Western Switzerland (HES-SO), School of Engineering and Business Vaud (HEIG-VD), Laboratory of Solar Energetics and Building Physics (LESBAT), Yverdon-les-Bains, Switzerland

\*Corresponding author; e-mail: [sebastien.lasvaux@heig-vd.ch](mailto:sebastien.lasvaux@heig-vd.ch)

#### Abstract

Following the Fukushima accident in 2011, Switzerland decided to start turning off the electricity coming from nuclear power plants as a part of an ambitious “Energy Strategy 2050” including better energy savings and efficiency of buildings and the development of renewable energies. In this new framework, one of the measures concerns the replacement of direct electric heating systems. It has been discussed in some Swiss cantons and increases the pressures on building tenants that use direct electricity as energy carrier e.g., for heating. However, from an environmental and economic point of view it is not clear yet whether it is better to renovate the building envelope, the electric heating systems or a combination of both. As several alternatives exist during a building renovation, the objective of this paper is to conduct an integrated economic and environmental assessment of four representative scenarios using the Life Cycle Assessment and Life Cycle Cost methodologies based on Swiss standards and cost data collected from manufacturers. From an economic point of view, results showed that the renovation of the electric heating system by a heat pump, solution often promoted by Swiss cantons, enables to get similar costs compared to the existing building. This solution is more interesting than the building envelope renovation or the switch to another heating system for which a technical room needs to be created. From an environmental point of view, the building envelope renovation is fundamental to lower the impacts. The partial renovation of the building envelope while keeping the direct electric heating system gives equivalent results compared to the only replacement of the electric heating by an air-to-water heat pump. Finally, this study shows that it is not always possible to be below the indicative values of the SIA 2040 standard “Energy Efficiency Path” (intermediate goals of the 2000-Watt Society) for the “Construction” and “Operational” aspects for building renovation.

#### Keywords:

Life cycle cost; life cycle assessment; residential buildings; renovation; electricity

## 1 INTRODUCTION

It is currently possible to design buildings with a nearly-zero energy consumption as well as buildings that produce more energy than they actually consume. By optimizing the choice of materials and integrated technical systems, these buildings can also present a low environmental impact. However, the situation is rather different for the existing building stock. When renovating a building, getting a substantial decrease of the

environmental impacts while keeping the costs down offers quite a challenge. The choice of a financially and environmentally potent solution turns out to be rather complex. Within this context, a national project funded by the Swiss Federal Office for Energy (SFOE) was conducted to investigate low environmental impact renovations of single family houses and multiple dwellings. This project aimed at improving the knowledge on the economic and environmental aspects of energy related renovation solutions by taking into

account not only the operational energy consumption but also the outcome of a Life Cycle Assessment approach which integrates both building materials and technical systems. A methodology to perform building economic and environmental analyses was defined, which helps in the decision making process. In particular, the substitution of direct electric heating by another type of heating system requires substantial effort. Indeed, several renovation scenarios can be considered. The aim of this paper is thus to assess them according to stakeholders' practices in the building renovation sector to highlight the most cost-effective ones.

## 2 MATERIALS AND METHODS

### 2.1 LCA and LCC methodologies

An energy-related building renovation LCA methodology was used based on the IEA EBC Annex 56 project [1]. The system boundaries and the calculation rules are compliant to the SIA 2032 [2] technical book recommendations used for the Minergie-ECO<sup>®</sup> standard. It only takes into account impacts linked to materials of the construction elements and technical systems part of the energy-oriented renovation. Environmental impacts are evaluated through two separate indicators: non-renewable primary energy (CED<sub>NRE</sub>) and greenhouse gases emissions (GWP). The environmental data is taken from the KBOB LCA recommendations list (2012 version) [3].

The financial calculation is based on the SIA 480 [4] standard. Federal and cantonal renovation subsidies are taken into account. Materials costs were obtained through manufacturers and suppliers. They are valid for the location of the buildings studied but could drastically differ for building situated in other areas. Regarding energy-related costs, the calculation method takes into account the initial investment, the maintenance costs as well as the cost of the energy vectors. No annual increase of the energy cost was considered for the heating costs. Given the high variability of the costs, also linked to the investment method (loan rates, etc.), an uncertainty margin of 20% was used for the LCC results.

The building lifespan is set at 60 years (in agreement with IEA Annex 56 recommendations). Materials and technical systems replacements are considered using lifespans close to SIA 2032 guidelines [2]. In all case studies, heating system efficiencies are compliant with the SIA 2040 technical book [5]. The only exception is the heat pump, which COP has been the object of a separate evaluation.

### 2.2 Building case studies

Two existing buildings built in Switzerland in the early 1980ies and heated with direct electricity

heating are used as case studies. The first one is a single family building (SFB) occupied by the landlord and the second one is a multi-family building (MFB) occupied by the tenants in the Vaud Canton. Indeed, in Switzerland, 38% of the housing are occupied by the landlords and 62% by the tenants [6]. Considering these two situations (owning and renting) enable to improve the study's representativeness.

First, each existing building is assessed before renovation (reference case). Then, LCA and LCC are done through an energy-related building renovation according to the four strategies defined in section 2.3. Figure 1 presents the pictures of the two case studies.



Fig. 1: Visualisation of the SFB (left) and MFB (right) case studies.

### 2.3 Renovation strategies

Four different renovation strategies are considered in this study:

- *Strategy A*: Substitution of direct electric heating by other systems (e.g., heat pump, natural gas boiler, pellets) without renovating the building envelope (scenario only relevant if the thermal envelope is not too outdated).
- *Strategy B*: Renovation only of the building thermal envelope
- *Strategy C*: Renovation of the building thermal envelope and replacement of the heating system.
- *Strategy D*: Renovation of the building envelope and direct electric heating system connected to a photovoltaic installation to balance the annual electricity consumption from the grid and lower the environmental impacts.

Within strategies A and B, different individual scenarios were first compared in preliminary studies to limit the combined scenarios within strategy C. These preliminary assumptions are presented below.

For the SFB case study, as the thermal envelope is not outdated, the substitution of the heat production system (strategy A) was preliminary studied. Different types of heating systems were compared including air-water heat pump (HP), fossil solutions or the pellets. A preliminary study shows, by taking into account the costs and the environmental impacts generated throughout the building lifespan and the technical constraints, that an air-water heat pump is a better choice than oil, natural gas or pellets. Similarly, regarding the

renovation of the thermal envelope (strategy B), the preliminary study led to add an external EPS insulation to the massive walls. The first storey walls that have a wooden structure were improved using EPS between the wooden beams and the roof was insulated with PUR. The addition of these renovation measures make the building comply with the Swiss standard SIA 380/1 renovation requirements [7]. In this paper, the optimal scenario within strategy B includes also the addition of a 2-IV glazing windows. Renovation through strategy C finally integrates both renovation of the thermal envelope (as in scenario B) as well as the replacement of direct electric heating by an air-water heat pump.

For the MFB case study, considering the state of its thermal envelope (visual aspect and thermal performance) and in agreement with the building owner, a renovation of the external insulation is required, excluding strategy A for this case study. Then, numerous alternatives within strategy B were compared for the external walls: ventilated or non-ventilated facades with various insulation materials. The optimal scenario finally corresponds to a ventilated façade with glass wool insulation and comply with the SIA380/1 renovation standard [7]. Finally, several renovations scenarios within strategy C were assessed considering different heat production systems: air-water heat pump and wood pellets (presented in section 3.2) as well as natural gas, light fuel oil and a geothermal heat pump (results not presented here due to paper length limitation).

	SFB	MFB
Strategy A	X	
Strategy B	X	X
Strategy C	X	X
Strategy D	X	X

Tab. 1: Renovation strategies considered for the SFB and MFB case studies.

For both case studies, a renovation scenario based on strategy D was also analysed by combining, next to the renovation of the envelope, a direct electrical heating with PV panels. Average solar cover percentages were retrieved from the Swiss Federal Office for Energy (SFOE) solar thermal guidelines and photovoltaic pre-sizing tools [8; 9] with respectively 60% of DHW cover (for SFB and MFB) with solar thermal collectors solar and 13% (for SFB) and 74% (for MFB) heating cover based on PV panels.

### 3 RESULTS

#### 3.1 SFB case study

Figure 2 presents the LCC results while figure 3 presents the LCA results (in terms of GWP and CED<sub>NRE</sub> indicators). Results are presented in Euros assuming a 1:1 exchange rate with the

Swiss Francs (CHF). For all the following graphics, results of the optimal scenario within a strategy is abbreviated with the letter of the strategy (A, B, C or D) complemented if relevant by the name of the heating system in brackets. Finding a global optimal solution that minimize both costs and all environmental impacts is not possible. Financial results on top of Figure 2 show that the substitution of the direct electric heating by an air-water heat pump, without renovating the thermal envelope, leads to lower yearly costs than the reference case. In all other renovation scenarios yearly costs are found higher than the reference case. Due to the very low cost of the heat pump, the total cost of this optimal scenario is found similar to the renovation cost of the thermal envelope (red bars on other variants). All other scenarios generate yearly costs which are situated within that 20% uncertainty margin. Renovation according to axis C leads to 25% to 35% over costs while strategy D is even more expensive. For all these variants, expenditure linked to the improvement of the thermal envelope performance is never compensated by the money saved through the reduction of the energy consumption.

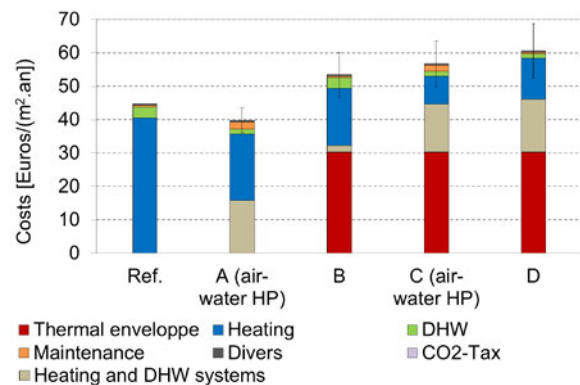

Fig. 2: LCC results for the SFB case study.

From an environmental perspective (Figure 3), replacing the electrical heating with an air-water heat pump (without touching the thermal envelope) reduces GWP and CED<sub>NRE</sub> impacts by half. This scenario's environmental performance is on par with other solutions from axis "C" but offers a much preferable solution from a financial point of view. When neglecting financial constraints, the optimal scenario is a complete renovation of the thermal envelope paired with the installation of an air-water heat pump. That solution reduces the greenhouse gases emissions by two thirds and non-renewable energy consumption by 75%.

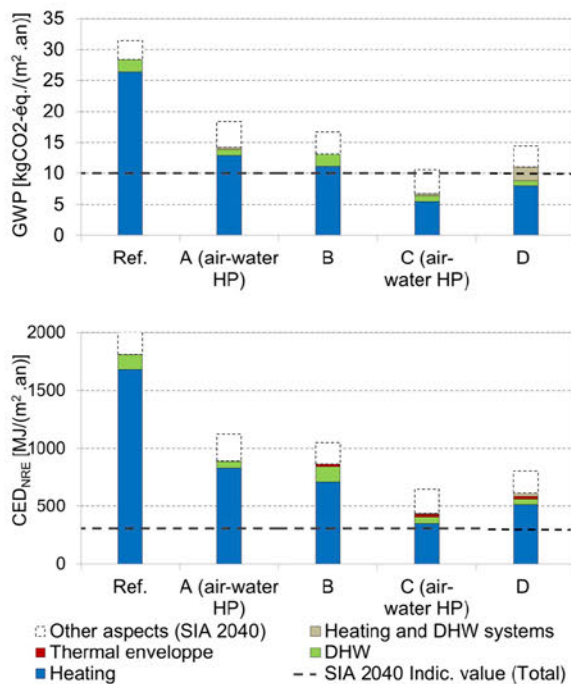

Fig. 3: LCA results expressed in GWP (top) and  $CED_{NRE}$  (bottom) for the SFB case study.

### 3.2 MFB case study

LCC results on Figure 4 show that all renovation scenarios generate annualised costs higher than the existing building.

The solution with the lowest over costs (around 7%) consists of keeping the existing heat production systems and renovating the thermal envelope (strategy A). Looking at the two scenarios from strategy C, the air-water HP is better (with 7% over costs) than the wood pellets solution where annualised costs are about 30% higher compared to the existing building. This can be explained by the high investments required for the technical systems (new boiler and hydraulic distribution network needed). Interestingly, when taking into account the uncertainty margin of 20% linked to the variability of the investment and maintenance costs, it is not possible to determine with confidence any optimal renovation solutions.

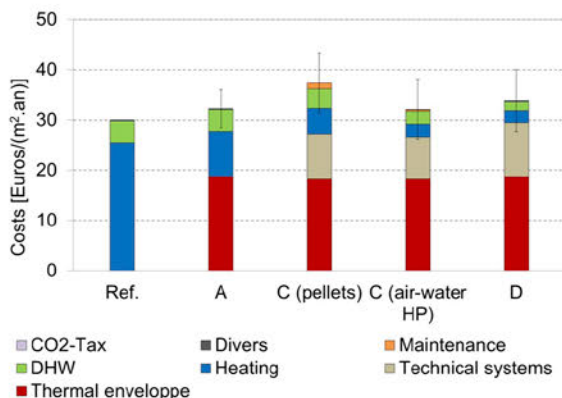

Fig. 4: LCC results for the MFB case study.

LCA results (Figure 5) expressed in GWP and  $CED_{NRE}$  are similar than those from the MFB case i.e., adding thermal insulation and replacing the electrical heating by an air-water heat pump (strategy C) is the best solution when trying to minimize greenhouse gases emissions and the non-renewable primary energy consumption.

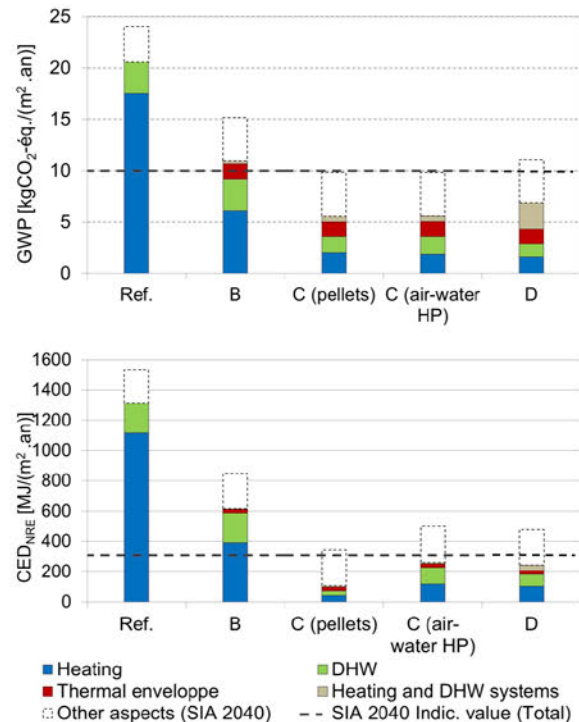

Fig. 5: LCA results expressed in GWP (top) and  $CED_{NRE}$  (bottom) for the MFB case study.

The strategy C (air-water HP) provides a good compromise as its yearly costs are quite similar to the initial situation. If a storage space can easily be found, a pellets boiler offers an interesting alternative. Environmental performance is also very high but yearly costs are around 10% superior. As there is an important amount of uncertainty linked to the financial data, this small costs difference falls within the uncertainty margin.

### 3.3 Comparison of LCA results with the SIA 2040 indicative values

The SIA 2040 technical book defines indicative and target values to move towards a 2'000-Watts Society (resp. a 1 ton CO<sub>2</sub>-eq Society) by defining intermediate goals for 2050 [5]. The SIA 2040 provides individual target values for building construction, operation, occupant's mobility for both greenhouse gases emissions and non-renewable primary energy consumption. In this paper, only the "construction" and "operation" SIA 2040 target values were calculated. Figure 3 and 5 present the results. For the operational aspects, default values proposed in SIA 2040 were used to take into account of the electricity needed for auxiliary, ventilation, lighting, sanitary and operating equipment. These end-uses are referred as "Other aspects (SIA 2040)" in Figure 3



and 5 while the SIA 2040 target value for construction and operation is displayed using a black dotted line.

Comparisons of the LCA results with the SIA 2040 target values showed:

- *For the SFB building:* none of the scenarios studied reaches the intermediate goals of the 2'000-Watts Society, both for CED<sub>NRE</sub> and GWP. The best scenario in terms of CED<sub>NRE</sub> and GWP (Renovation of the thermal envelope combined with an air-water HP) is also far from the total SIA 2040 indicative value.
- *For the MFB building:* two scenarios are below the SIA 2040 target value regarding CED<sub>NRE</sub> while none of the scenarios comply with GWP target value. However, the "pellets" scenario, which consists of a renovation of the thermal envelope combined with wooden pellets heating, is very close to complying with SIA 2040 target values.

#### 4 DISCUSSION AND CONCLUSION

For the financial indicator, the replacement of direct electricity heating systems in Swiss residential buildings is not interesting if a storage or a technical room needs to be built for the new heating system. The replacement of the direct electricity heating by a new air-water heat pump without renovating the envelope, solution often recommended by the Swiss cantons, allows a little financial pay back compared to the building before renovation. This finding is in line with previous studies such as Risholt and al. [10]. This choice remains robust even when assuming an uncertainty margin of 20% linked to the variability of the investment and maintenance costs. However, it is important to recall that the renovation of the building envelope is often a needed action to maintain the building in a good state (as shown for the MFB case) while it is not the case for the replacement of the heating system. In all other cases, this study has shown that the cost of renovation is never compensated by the money saved through the reduction of the energy consumption. In both case studies, the thermal envelope renovation is a costly operation which will not be paid back within the 60 years of the building lifespan. The outcomes of this study has different consequences depending on the type of building occupants. On the one side, the over costs will be more easily paid back in MFB occupied with tenants as the landlord will be able to adjust the monthly rents following the renovation of the building. On the other side, this situation will not happen for a building occupied by a landlord as it was the case in this study for the single-family building.

From an environmental point of view, the thermal building renovation is important to lower the total impacts including the operation heating demand.

The share in the environmental impacts due to the added insulation materials remain small compared to the heating energy savings. This finding is in line with previous studies except the study from Gustavsson L. and Joelsson A. [11]. In that case, they found that the choice of energy supply system affects more the environmental impact than the energy-efficiency measures to improve the building envelope. This difference between our study and their study can be explained by different building factors (U-values, efficiency of technical heating systems) or database environmental impact (materials and energies).

In this paper, it was also found that the renovation of the envelope combined with the maintenance of the direct electricity heating is similar to the replacement by a heat pump without renovating the envelope. Results compared with the intermediate 2050 goals of the 2'000-Watts Society show that it is not easy to get results lower than the combined indicative values for construction and operation in the specific case of residential buildings' renovation. As the mobility related impacts were not included in this study, it is not possible to conclude on a broader system boundary including mobility aspects (2'000-Watts Society requirements). Furthermore, additional electricity consumption linked to ventilation, auxiliary, lighting and operating equipment has been taken into account using default values provided by SIA 2040. A more accurate evaluation of those energy needs would perhaps slightly scale down energy-related impacts.

Combined LCA and LCC results have shown that 2000-Watts Society intermediate 2050 objectives are not easy to reach in a cost-effective way when renovating existing buildings. It does not mean that these buildings should not be renovated as most renovation scenarios studied generate a drastic reduction of primary energy and CO<sub>2</sub> emissions for the operational energy. Finally, besides technical, economic and environmental constraints, it is also important to include in the assessment social impacts induced by the renovation and also the co-benefits of the renovation concerning the well-being of occupants, the potential improved indoor air quality and other similar aspects.

#### 5 ACKNOWLEDGMENTS

The authors of this paper would like to gratefully thank the Swiss Federal Office for Energy (SFOE) for its financial support through the ECO Reno research project.

## 6 REFERENCES

1. IEA EBC Annex 56, <http://www.iea-annex56.org/>
2. Société Suisse des ingénieurs et des architectes, Cahier technique SIA 2032, L'énergie grise des bâtiments, 2010.
3. Conférence de coordination des services de la construction et des immeubles des maîtres d'ouvrage publics (KBOB), Liste des écobilans dans la construction, 2012.
4. Société Suisse des ingénieurs et des architectes, norme SIA 480, Calcul de rentabilité pour les investissements dans le bâtiment, 2004.
5. Société Suisse des ingénieurs et des architectes, Cahier technique SIA 2040, La voie SIA vers l'efficacité énergétique, 2011.
6. Office fédéral de la statistique (OFS), [http://www.bfs.admin.ch/bfs/portal/fr/index/themen/09/03/blank/key/bewohnertypen/nach\\_region.html](http://www.bfs.admin.ch/bfs/portal/fr/index/themen/09/03/blank/key/bewohnertypen/nach_region.html)
7. Société Suisse des ingénieurs et des architectes, norme SIA 380/1, L'énergie thermique dans le bâtiment, 2009.
8. Office fédéral de l'énergie, Dimensionnement d'installations à capteurs solaires, 2001.
9. Meteotest, PV calculator, <https://pvcalc.meteotest.ch/>
10. Risholt B and al., 2013, Sustainability assessment of nearly zero energy renovation of dwellings based on energy, economy and home quality indicators, Energy and Buildings
11. Gustavsson L., and Joelsson A., 2009, Life cycle primary energy analysis of residential buildings, Energy and Buildings



## Expanding Boundaries: Systems Thinking for the Built Environment

### ENVIRONMENTAL EFFECTS OF AN ALPINE SUMMIT TUNNEL

F. Gschösser<sup>1,2\*</sup>, W. Purrer<sup>3</sup>, P. Sander<sup>4</sup>

<sup>1</sup> Leopold-Franzens University of Innsbruck, Unit of Project and Construction Management, Technikerstraße 13, A-6020 Innsbruck, Austria

<sup>2</sup> floGeco – Environmental Management, Hinteranger 61d, A-6161 Natters, Austria

<sup>3</sup> Construction Contract Consultant Purrer, General-Feurstein-Straße 23c, A-6020 Innsbruck, Austria

<sup>4</sup> RiskConsult GmbH, Technikerstraße 32, A-6020 Innsbruck, Austria

\*Corresponding author; e-mail: [florian.gschoesser@uibk.ac.at](mailto:florian.gschoesser@uibk.ac.at)

#### Abstract

Since many years the construction of a summit tunnel on the analysed alpine pass route is discussed (\*due to confidentiality reasons the name of the route cannot be disclosed). In recent years a tunnel-path study and a traffic analysis were carried out to determine the optimum position for the tunnel and its influence on the traffic situation.

This Life Cycle Assessment (LCA) study analyses construction, maintenance and operation of the optimum tunnel variant over an analysis period of 100 years. The LCA results consider the new traffic situation and the environmental savings caused by the shortened and flattened route due to the new tunnel.

The analysis of the tunnel bases on data from the path study, geological studies, comparable tunnel projects and expert knowledge. The tunnel has a total length of 1.500 m and a maximum gradient of 4 %. A rescue tunnel with a length of 600 m accompanies the main tunnel. The tunnel is constructed by applying the New Austrian Tunnelling Method (NATM).

The traffic LCA evaluates both the situations with and without tunnel for the years 2013 and 2025 (based on the traffic analysis). The existing tunnel causes a traffic load rise on the pass route, what furthermore causes more traffic jam situations on main traveling days.

The results show that the environmental impacts caused by constructing, maintaining and operating the tunnel are environmentally “amortised” within a short period due to the usage of the tunnel and the shorter route as well as the avoidance of the top of the pass (for Global Warming Potential within 10 years, for Acidification Potential within 5 years, for Non-renewable Cumulative Energy Demand within 6 years). These results show the great environmental potential of route-shortening transport infrastructures.

Due to the short “amortisation period”, the influence of future engine technologies and fuels was considered only in a qualitative form.

#### Keywords:

Alpine summit tunnel; Life cycle assessment; Construction; Maintenance; Operation; Traffic

### 1 INTRODUCTION

Since many years there was an on-going discussion regarding the construction of a summit tunnel on this alpine pass route. In recent years a tunnel-path study and a traffic study were carried out to determine the optimum position for the tunnel and its influence on the traffic situation.

Based on these two studies a Life Cycle Assessment (LCA) was carried out to demonstrate the environmental influence of a tunnel on the pass route. This LCA study analyses construction, maintenance and operation processes of the optimum tunnel variant over an analysis period of 100 years. The results of the tunnel LCA are compared to

the new traffic situation and the environmental savings caused by the (due to the tunnel) shortened and flattened route.

Thus the core issue of this study can be expressed as:

*When will the optimised route and the connected environmental savings due to less fuel consumption compensate the environmental impacts caused by the tunnel construction, maintenance and operation?*

## 2 BACKGROUND

### 2.1 Tunnel-path study

The goal of the study was the development of several path variants for a tunnel undercutting the summit of the pass route. Also a rough cost overview for all developed variants and specific recommendations for further project steps are included.

Finally, the path variant with two tunnel sections connected by an open track was chosen to be the optimum solution due to its low longitudinal gradient (max. 4 %), short tunnel length (1070 m and 500 m), little safety requirements (rescue tunnel 600 m) and lower construction costs (€ 67 Mio.).

### 2.2 Traffic study

Within this study the traffic-influence of the tunnel was analysed for two different situations:

- Working days
- Traveling days (winter and summer)

For average working days the study determined the number of journeys over the pass route for both the situation with and without the summit tunnel. Thereby the focus was put on the traffic growth due to the new tunnel. *Table 1* shows the total number of journeys on an average working day of the year 2013.

For traveling days the focus was put on the number of journeys with congestion or slow moving situations and the caused delay time (*Table 2*). Due to the fact that the pass route already tends to take maximum traffic loads on traveling days, no traffic growth for the situation with the new tunnel was considered. The traffic loads were taken from traffic counts on typical traveling days (2013). However, a traffic growth of 10% for the analysed period (2013 to 2025) was considered. *Table 1* shows the total number of journeys for typical traveling days of the year 2013.

The percentage of journeys within congestion or slow moving situations was determined to be 32% of the daily traffic load for traveling days in winter and 50 % for traveling days in summer.

	Working day 2013				Traveling day - winter 2013		Traveling day - summer 2013	
	Without tunnel		With tunnel		Without & with tunnel		Without & with tunnel	
<b>Transit traffic via the pass</b>	Cars	Lorries	Cars	Lorries	Cars	Lorries	Cars	Lorries
<b>Direction North</b>								
A – D	821	364	966	377	4938	216	1039	62
B – D	1952	409	2177	406	4664	204	2390	143
<b>Direction South</b>								
D – A	900	210	1070	211	5572	222	1385	85
D – B	2492	563	2857	565	5498	219	2985	184
<b>Originating and terminating traffic via the pass</b>								
<b>Direction North</b>	Cars	Lorries	Cars	Lorries	Cars	Lorries	Cars	Lorries
C – D	291	13	297	14	1371	60	2202	132
<b>Direction South</b>								
D – C	571	17	592	19	1313	52	2353	145
<b>Originating and terminating traffic via A</b>								
<b>Direction North</b>	Cars	Lorries	Cars	Lorries	Cars	Lorries	Cars	Lorries
A – C	4401	80	4399	80	4738	40	3096	86
<b>Direction South</b>								
C – A	4505	75	4506	73	6411	76	2994	91
<b>Originating and terminating traffic via B</b>								
<b>Direction North</b>	Cars	Lorries	Cars	Lorries	Cars	Lorries	Cars	Lorries
B – C	500	16	493	15	51	2	1093	263
<b>Direction South</b>								
C – B	528	17	523	16	53	2	1374	17
<b>Transit traffic A – B</b>								
	Cars	Lorries	Cars	Lorries	Cars	Lorries	Cars	Lorries
A – B	86	11	89	11	86	11	43	6
B – A	61	5	60	5	61	5	31	3

*Table 1: Total number of journeys per day for 2013.*

Traveling day - winter					
Direction north			Direction south		
A - D			D - A		
Lost time [min]	without tunnel	with tunnel	Lost time [min]	without tunnel	with tunnel
2013	26	31	2013	18	16
2025	40	41	2025	24	22
B - D			D - B		
Lost time [min]	without tunnel	with tunnel	Lost time [min]	without tunnel	with tunnel
2013	27	35	2013	16	16
2025	42	54	2025	22	22
Traveling day - summer					
Direction north			Direction south		
A - D			D - A		
Lost time [min]	without tunnel	with tunnel	Lost time [min]	without tunnel	with tunnel
2013	34	34	2013	18	18
2025	55	57	2025	40	32
B - D			D - B		
Lost time [min]	without tunnel	with tunnel	Lost time [min]	without tunnel	with tunnel
2013	35	35	2013	16	18
2025	56	74	2025	39	32

Table 2: Time loss due to congestion.

### 3 LIFE CYCLE ASSESSMENT (LCA)

#### 3.1 Tunnel LCA

The goal of the tunnel LCA study is the environmental assessment of the construction processes of the tunnel as well as its maintenance and operation over 100 years [1]. The system boundaries include all construction, maintenance and operation processes over the analysis period. The functional unit of the study is defined as “one tunnel built for the traffic volume occurring on the pass route over 100 years”.

It is assumed that for tunnel excavation NATM (New Austrian Tunnelling Method, drilling and blasting) is applied. The new construction

processes were modelled together with experts from construction companies. Based on the geological situation based on the tunnel-path study the specific tunnel excavation and support categories were defined.

In the next step all required construction and auxiliary materials, construction equipment, energy resources as well as all transport (to construction site and landfill) and landfill processes (excavation material) were determined for each excavation and support category.

In accordance with the involved tunnelling experts it was defined that all maintenance processes occurring over the analysis period of 100 years can be considered by a surcharge of 10 % for all construction processes.

The environmental impacts of the construction processes were analysed in a very detailed manner. Due to the limited content of this paper only the overall results for construction processes (incl. maintenance surcharge, rescue tunnel and road construction) are depicted (Fig. 1).

The indicators utilized to express the environmental impacts are:

- Global Warming Potential (GWP) [kg CO<sub>2</sub> eq]
- Acidification Potential (AP) [kg SO<sub>2</sub> eq]
- Non-renewable Cumulative Energy Demand (Nr-CED) [MJ eq]

The LCA was conducted using the software SimaPro and the ecoinvent database 2.2.

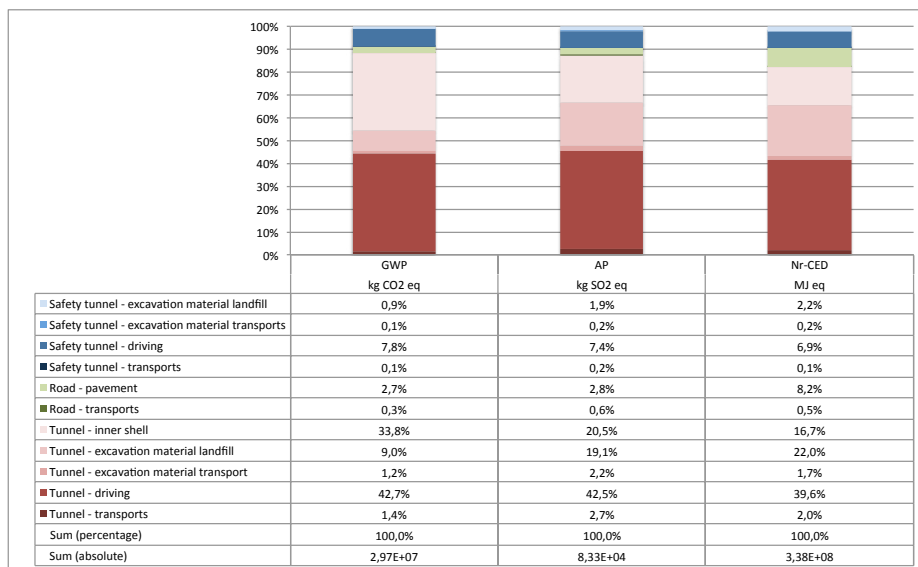

Fig. 1: LCA results tunnel new construction including maintenance.

The results in Fig. 1 show the great influence of tunnel excavation processes and the construction of the inner lining. These great influences are mainly caused by the shotcrete applied for the tunnel excavation and the concrete forming the inner lining.

The main components for the tunnel operation are electric lighting and ventilation. The equipment and the required electricity needed for the tunnel operation were modelled according to data of similar tunnels. Additional operation processes (e.g. for tunnel safety equipment) were considered by a surcharge of 5 % on top of electric lighting and ventilation. The comparison of the environmental impacts of the tunnel operation over 100 years and all construction processes (including maintenance surcharge) shows that operation processes cause only 20 to 40 % impact in comparison to construction and maintenance processes. Traffic LCA

For the traffic LCA in a first step the longitudinal gradients of the pass routes were modelled for the situation with and without the tunnel.

In 2013 the average fuel consumption in Austria was 6 litres per 100 km for diesel operated and 7 litres for gasoline operated passenger cars. The average fuel consumption for an average lorry was 25 litre diesel per 100 km. Fuel consumption increases with a rising longitudinal gradient. Downhill this extra fuel consumption should be theoretically compensated by the potential energy obtained when driving uphill. However, this theoretical compensation cannot be achieved in practice due to necessary braking manoeuvres. In agreement with consulted mechanical engineers, it was set that when going downwards 50 % (cars) respectively 10 % (lorries) of the extra consumption for uphill gradients is compensated. The additional fuel consumption to travel differences in height is determined by the following formula [2]:

$$F_{height} \left[ \frac{l}{100 \text{ km}} \right] = \text{mass [kg]} * \text{height difference [m]} * \frac{1}{1000 * 3600} * \frac{100}{\text{distance [km]}} * \frac{1}{0,98}$$

$$v_{pe} \left[ \frac{l}{kWh} \right] \dots \text{consumption efficiency} \left[ \frac{l}{kWh} \right] \dots 0,264 \text{ for gasoline}; 0,220 \text{ for diesel} \quad (1)$$

Regarding the fuel consumption during congested conditions, it was defined (in accordance with the consultants) that the consumption within three minutes congestion corresponds with the consumption for one kilometre average ride. Based on this approach the consumption per minute of delay time during congested conditions was determined.

With the different fuel consumptions (average, height differences, congestion), the daily number of journeys (2013 and 2015) and the percentage of journeys affected by congestion the total fuel use on average working days and traveling days was calculated for the scenario with and without the tunnel. The number of traveling days was determined within the traffic study (17 winter, 24 summer). For the remaining days of the year the fuel usage of an average working day was applied. As a next step the average fuel use for 2013 and 2025 was calculated and utilized for the comparison between the scenario with and without the tunnel.

#### 4 TUNNEL VS. TRAFFIC

The last part of the LCA study compares the results of the tunnel LCA with the environmental savings generated by the reduction of fuel consumption due to the tunnel. Fig. 2 to Fig. 4 demonstrate the environmental effects of the summit tunnel. The impacts caused by the construction occur over a period of two and a

half years (these impacts already include the 10% surcharge for all maintenance processes). The environmental savings due to the reduced fuel consumption were determined for the years 2013 and 2025. Thus, the recovery of the construction impacts is determined separately for the savings of both years and with a linear approach. The impacts caused per year of tunnel operation counter the yearly savings caused by the fuel reduction.

Although the tunnel causes a higher traffic load on the pass route, the results show that the environmental impacts, caused by the tunnel construction, maintenance and operation, are environmentally "amortised" within a short period. This amortisation is caused by the usage of the tunnel and the shorter route as well as the avoidance of the top of the pass (for Global Warming Potential within 10 years, for Acidification Potential within 5 years, for Non-renewable Cumulative Energy Demand within 6 years). Since the analysis period was set to 100 years, future developments regarding engine technologies and fuels should be considered within the study. However, due to the short "amortisation period" the influence of these future technologies was taken into account only in a qualitative form (Fig. 2 to Fig. 4).

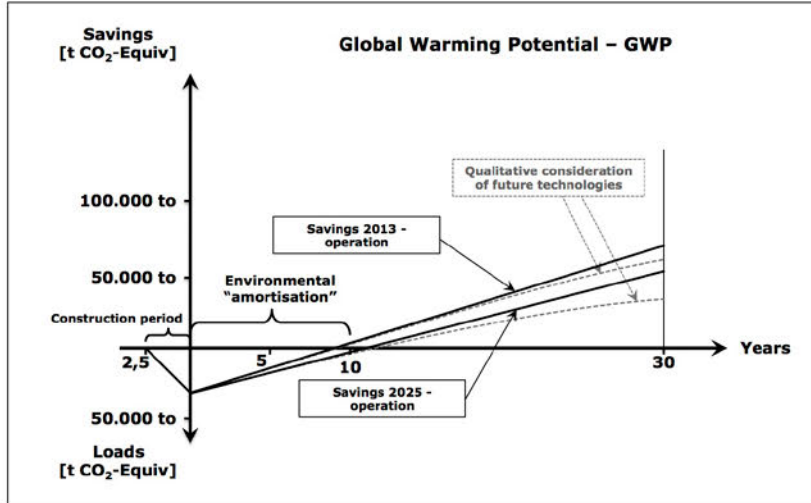

Fig. 2: Environmental effect of the tunnel – GWP

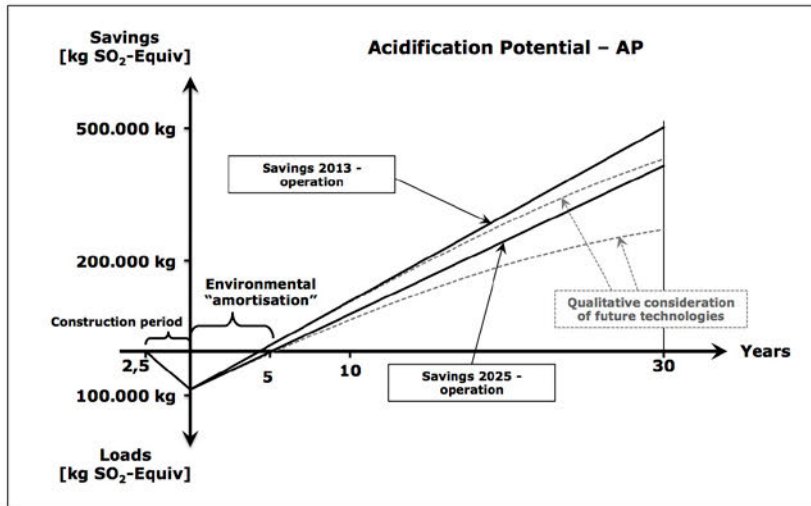

Fig. 3: Environmental effect of the tunnel – AP.

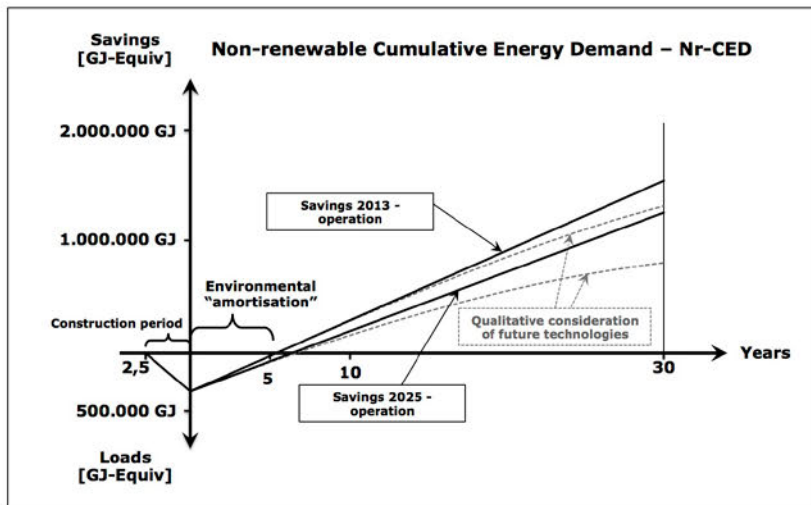

Fig. 4: Environmental effect of the tunnel – Nr-CED.

## 5 DISCUSSION AND CONCLUSIONS

The results of this LCA study underline the great environmental potential of route-shortening transport infrastructures such as tunnels and bridges.

However, the study does not include further aspects, which need to be considered for an overall sustainability assessment of a transport infrastructure (e.g. noise generation, disturbances for residents, economic aspects, etc.) [3]. At the moment the working group 6 of the CEN/TC/350 develops standardisation documents for the sustainability assessment of civil engineering works aiming to include all necessary aspects and indicators [4]. These standardisation documents can then be the base for future (overall) assessments of transport infrastructures.

## 6 REFERENCES

1. ISO, *ISO 14040:2006 - Environmental management - Life cycle assessment - Principles and framework*. 2006, International Standard Office: Geneva.
2. Liebl, J., et al., *Energiemanagement im Kraftfahrzeug*. 2014: Wiesbaden.
3. Gschösser, F. and H. Wallbaum, *Life Cycle Assessment of Representative Swiss Road Pavements for National Roads with an Accompanying Life Cycle Cost Analysis*. Environmental Science and Technology, 2013. **47**(15): p. 8453–8461.
4. CEN. *Overview of CEN/TC 350*. 2015 [cited 15.01.2015 15.01.2015]; Available from: [http://portailgroupe.afnor.fr/public\\_espacenormalisation/centc350/chairman\\_remark.html](http://portailgroupe.afnor.fr/public_espacenormalisation/centc350/chairman_remark.html).





## Expanding Boundaries: Systems Thinking for the Built Environment

### SELECTION OF ENVIRONMENTAL DATASETS AS GENERIC DATA: APPLICATION TO INSULATION MATERIALS WITHIN A NATIONAL CONTEXT

J. D. Silvestre<sup>1\*</sup>, S. Lasvaux<sup>2,3</sup>, J. Hodková<sup>4</sup>, J. de Brito<sup>1</sup>, M. D. Pinheiro<sup>1</sup>

<sup>1</sup> CERIS, Department of Civil Engineering, Architecture and Georresources of Instituto Superior Técnico (DECivil-Técnico), Universidade de Lisboa, Portugal

<sup>2</sup> University Paris-East, Scientific and Technical Centre for Buildings (CSTB), Environment and Life Cycle Engineering Division, France

<sup>3</sup> University of Applied Sciences of Western Switzerland (HES-SO), Laboratory of Solar Energetics and Building Physics (LESBAT), Switzerland

<sup>4</sup> Department of Building Structures, Faculty of Civil Engineering, Czech Technical University in Prague, Czech Republic

\*Corresponding author; e-mail: jose.silvestre@tecnico.ulisboa.pt

#### Abstract

*Purpose:* The aim of this paper is to present the application of the NativeLCA methodology to the selection of Life Cycle Assessment (LCA) datasets of insulation materials to be used as generic data within a national context.

*Method:* NativeLCA is applied to the following products: stone wool (SW), polyurethane and insulation cork boards, expanded and extruded polystyrene, and lightweight expanded clay aggregates. Following the NativeLCA methodology, a review of available datasets for these insulation products is presented (i.e. generic LCA and Environmental Product Declaration databases). For each material (except SW), the aim was to verify the plausibility of LCA studies completed based on site-specific data, in order to use the latter as generic data within a national context.

*Results and discussion:* The case studies presented in this paper demonstrate the applicability and usefulness of using NativeLCA in the selection of a coherent dataset as generic data within a national context. Moreover, the application of this methodology to six case studies showed its feasibility, benefits, and limitations, while allowing the identification of some potential improvements.

*Conclusion:* NativeLCA relies on the selection of LCA data sets of construction products available in the European context to be used as generic for a national context. This is a straightforward approach, focused on the selection of a LCA data set to be directly used by LCA practitioners. The scope of NativeLCA was limited in this paper to insulation materials, but this methodology can be applied to other building products.

#### Keywords:

Data quality; EPD; Insulation materials; generic data; LCA

## 1 INTRODUCTION

The NativeLCA methodology guides the selection of representative Life Cycle Assessment (LCA) datasets of building products to be used as generic data for a national context [1]. This topic is particularly important because LCA studies of buildings require a large amount of data on building materials, products and processes. However, practitioners and developers of building LCA tools currently face practical issues when selecting data for the assessment of a building in a specific region [1].

This paper presents the application of NativeLCA to 5 insulation materials: stone wool (SW), polyurethane (PUR) and insulation cork boards (ICB), expanded (EPS) and extruded polystyrene (XPS), and lightweight expanded clay aggregate (LWA). The aim is to verify the plausibility of LCA studies completed in Portugal based on site-specific data ([2], following EN 15804:2012+A1:2013 and using Ecoinvent, ELCD and Plastics Europe for background data), in order to use these results as generic data within that national context. However, for SW, the aim is to select a coherent LCA dataset to be used

as generic data for this product, since no LCA data is yet available in this country. A discussion on the insulation that presents lower environmental impact is out of the scope of this paper (a comparison of these results was already presented by the authors in other paper [2]).

## 2 THE NATIVELCA METHODOLOGY

First, a review of available datasets for these insulation products, such as generic LCA and Environmental Product Declarations (EPD) databases for both national (e.g. France, Germany, Spain, etc.) and European context, was completed. Then, appropriate generic datasets were chosen by means of a hybrid methodology: in the first step a meta-analysis is conducted on the sample of collected datasets from the literature. When relevant, product specific data (EPD of the different producers) are averaged to represent an average data (reference value - REVA), or existing generic data are adapted to be more suitable for the context. The use of data quality indicators then helps in selecting the relevant generic data for each context according to users' needs (Figure 1). However, the results from the meta-analysis can also be used to verify the plausibility of LCA studies completed based on site-specific data, in order to use the latter as generic data within a national context.

## 3 RESULTS AND DISCUSSION

### 3.1 Lightweight Expanded Clay Aggregate (LWA)

NativeLCA is used in this case for the comparison between LCA results for LWA (A1-A3 standardised product stage; for a bulk density of 297 kg/m<sup>3</sup> and 8-16 mm) of a Portuguese company [2], an individual EPD (from the Norwegian system) and a generic data set (from Ecoinvent). Figure 2 presents the relative differences between the Portuguese results and foreign data sets for the three most important impact categories after normalisation.

The Norwegian EPD is based on a 2007 study of the production process of LWA in bulk of a Norwegian company. The figures of this data set are very similar only to the Portuguese study in Global Warming Potential - GWP (the impact is only 5% higher), but are much lower in the remaining environmental categories (between 75% in AP - Acidification Potential, and 79% in PE-NRe - Non-Renewable Primary Energy consumption). The Portuguese plant does not yet use secondary fuels in the oven, but the Norwegian one already uses them. Considering the amount of secondary fuels used by the latter, 10% of the difference in NRe can be explained. Another parcel can be explained by the significant share of renewable energy in the Norwegian electricity mix. Taking into account the significant contribution of coke production to AP and NRe in the Portuguese case study, it is of paramount importance to know the characteristics and amount of fuels used in the oven in the Norwegian company to fully explain the differences found in both categories. However, this information is not provided in the corresponding EPD. Taking into account this absence of data, it is not possible to make more inferences concerning the causes of the differences found in NRe. However, the analysis of the remaining environmental impact categories shows that the Norwegian data set has a higher impact in Photochemical Ozone Creation Potential - POCP than the Portuguese one (57% more). This difference, along with an inverse difference in AP, can be related to the secondary fuels used only in the Norwegian plant that can lead to a different combination of air emissions resulting in a higher impact in POCP and a lower impact in AP.

The Ecoinvent data set for LWA production (ECO17 in Figure 2) includes packaging and therefore the comparison between this data set and the Portuguese results considered two hypotheses of LWA packaging (palletised Polyethylene (PE) bags and Polypropylene (PP) bags). The Ecoinvent data set has higher results than the Portuguese study only in GWP (between 20% and 31%) and lower results in the remaining environmental categories (between

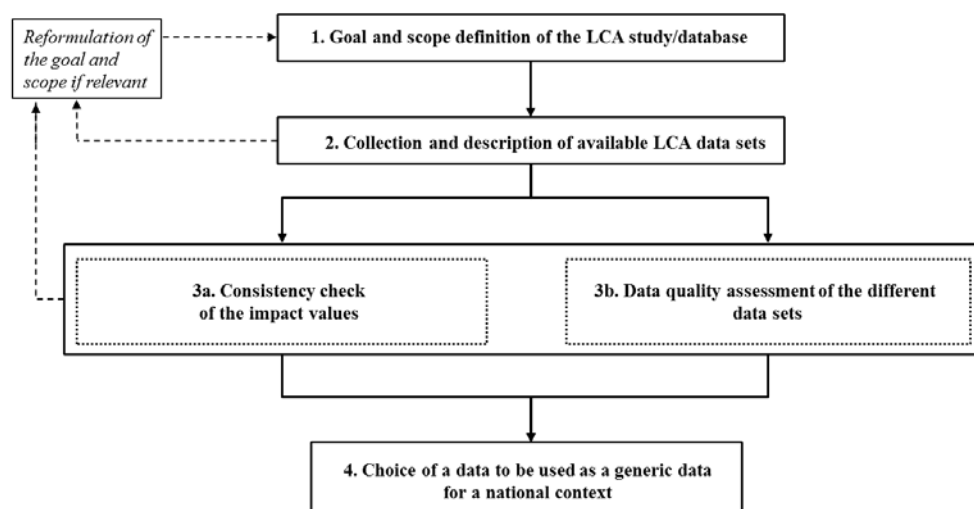

Fig. 1: NativeLCA methodology flowchart [1].

around 34% in AP and between 47% and 51% in PE-NRe). This data set is based on literature and on data from the period between 1995 and 2000. Along with these limitations of representativeness, it was found that the LWA production process uses around half of the electricity and less than 25% of fuels (and only heavy fuel oil, without considering petroleum coke) compared with the Portuguese case-study. Therefore, a trial was made with a “virtual” modification in the manufacturing of the LWA studied in Portugal: the same amount of electricity and heavy fuel of the Ecoinvent process. This “virtual” LWA tries to reproduce the latter, maintaining the other characteristics of the product studied (and also the air emissions from the Portuguese plant). Figure 3 shows the differences found between Ecoinvent and the “virtual” product described. It was confirmed that most of the differences in NRe and AP stemmed from the assumptions related to the lower quantity of fossil fuels and electric energy consumption of the Ecoinvent process. The “virtual” product indeed shows a lower difference to Ecoinvent in these categories (from 34% to around 21% in AP and from around 50% to  $\leq 22\%$  in NRe). However, in this case Ecoinvent has an even higher difference in GWP, which can be justified by the significant improvements of production technology in different sectors that have been made in order to reduce greenhouse gases between 1995 and 2012 (which can be confirmed by GWP figures of the Norwegian EPD and of the Portuguese case study).

Benchmarking of Portuguese results for LWA confirmed that these results are plausible and can be used in LCA of buildings in the Portuguese context, despite the lack of detailed data concerning the technology for LWA production in the Norwegian EPD and a poor temporal and geographical representativeness of the Ecoinvent data set.

### 3.2 Extruded Polystyrene (XPS)

For XPS, 1 individual (from an Italian company from the International EPD system - ENV) and 2 joint (1 from 5 companies all over Europe and another one from 5 companies that sell in the German market, both available in the German system) EPD are available for XPS boards with characteristics similar to the ones studied. A European REVA was also calculated via an arithmetic mean according to the number of companies included in each data set. All these data sets correspond to the set of blowing agents used in the Portuguese plant for thicknesses  $\leq 80$  mm (dimethyl ether and carbon dioxide). For the other set of blowing agents (difluoroethane and ethanol, for thicknesses  $\geq 80$  mm), the only data set available is Ecoinvent (with 4 different data sets, depending on the set of blowing agents used). However, all Ecoinvent processes for XPS production consider polystyrene (PT) expandable beads as raw material, but this raw material is not used at XPS plants, rather in EPS plants. Instead, XPS production uses polystyrene pellets (General

Purpose PT, GPPS). Thus, this comparison is only valid for XPS boards with thicknesses  $\leq 80$  mm.

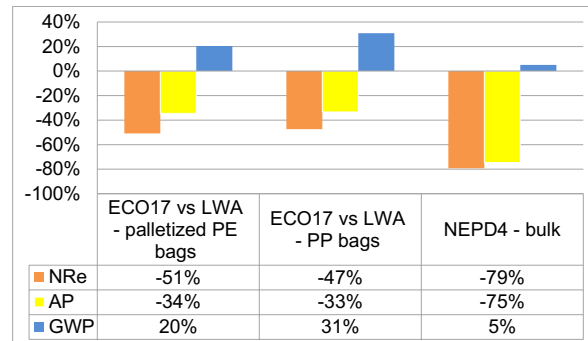

Fig. 2: Differences in PE-NRe, AP and GWP in the production of 1 kg of LWA between Portuguese site specific data and generic data set (Ecoinvent - ECO17) and individual EPD (NEPD).

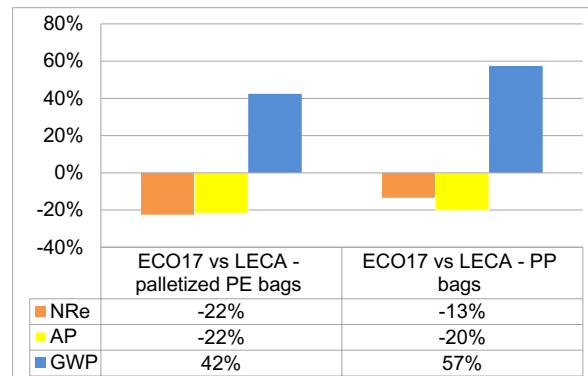

Fig. 3: Differences in PE-NRe, AP and GWP in the production of 1 kg of LWA (A1-A3) between Portuguese site specific data and generic data set (Ecoinvent - ECO17) (from LWA with a modified manufacturing process).

The results achieved for the LCA of the Product stage (A1-A3) of XPS boards of a Portuguese company [2] were compared with the ones included in the 3 EPD and with the European REVA, and the relative differences found for 3 impact categories (Figure 4). This comparison was made considering the same thermal performance for the XPS boards represented by each data set (considering the thickness of each board necessary to achieve a thermal resistance of the layer of  $1 \text{ (m}^2 \cdot \text{°C)/W}$ , taking into account the corresponding density and thermal conductivity).

The main difference found in the comparison between Portuguese results and German joint EPD (IBU13 and IBU14 in Figure 4) is in POCP (between 5% and 41% higher in the EPD). POCP are, in the Portuguese study, mainly (94%) caused by the air emissions during manufacturing, namely due to the release of dimethyl ether during the extrusion process. Due to the lack of site specific data concerning the percentage of this blowing agent that is released during this stage, it was considered that 25% of the quantity of this compound initially included in the mixture is freely released to the atmosphere during the gate-to-gate stage.

This value was based on the Ecoinvent process for XPS because EPD do not quantify this percentage, despite referring to it. Therefore, it is probable that EPD consider a higher percentage of this blowing agent released during the manufacturing stage.

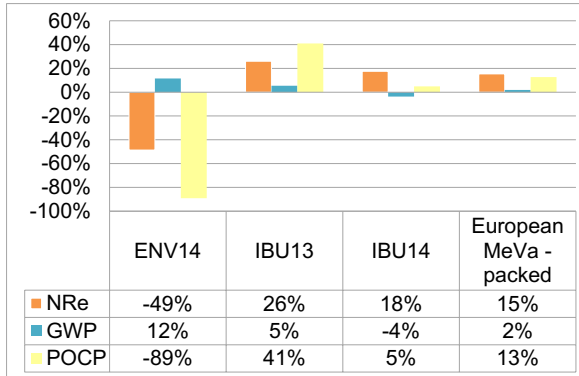

Fig. 4: Differences in PE-NRe, GWP, and POCP for XPS boards (A1-A3, with thickness  $\leq 80$  mm) with the same thermal performance between Portuguese site-specific data and European REVA and individual (ENV) and joint (IBU) EPD.

The joint EPD and Portuguese results are very similar in GWP (differences  $\leq 5\%$ ) and are similar in NRe (difference between 18% and 26%). It must also be highlighted the higher similitude of the Portuguese figures with the joint EPD based on data from a higher number of plants (IBU14 in Figure 4, from 18 plants, while IBU13 is based on data from 5 plants) and with European REVA (corresponding to an average result of 24 plants), than with IBU13 or with the individual EPD. In fact, the individual EPD presents very different results from the other data sets in NRe and POCP (49% and 89% lower than the Portuguese results, respectively, and even lower than the joint EPD), despite having similar composition and physical characteristics. In terms of GWP, the difference is only 12%. Looking at the meta data of this EPD, the background database used to model PE pellets is not declared. This raw material has a high contribution to NRe and the use of a different background process to model its production can explain the differences found in this impact category (because the Portuguese case study and the joint EPD used the same background process). Concerning the differences found in POCP, the difference found has to rely on a much lower quantity of hazardous air emissions during manufacturing accounted for in the individual EPD.

The plausibility of the Portuguese LCA study of XPS production was checked through a benchmarking with European EPD. Despite the assumptions made concerning the release of the blowing agent during manufacturing, it can be considered that the results achieved for the Portuguese case study are plausible and can be used in LCA of building assemblies in the Portuguese context.

### 3.3 Expanded Polystyrene (EPS)

Two individual (from the French and ENV) and 1 joint (from 24 European companies, available in the German system) EPD are available for EPS boards with characteristics similar to the one studied. A European REVA was not calculated because it would be similar to the joint EPD that contributes with a 92% share (24/26 companies).

The results achieved for the Product stage (A1-A3) of EPS boards (site specific data from a LCA study of a Portuguese company [2]) were compared with the ones included in the 3 EPD, and the relative differences found for three important impact categories are presented in Figure 5. This comparison was made considering the same thermal performance for the EPS boards represented by each data set (similarly to the XPS case study). Concerning PE-NRe and GWP, it was found that the EPD present figures between 14% and 53% lower than Portuguese results. Two causes can justify this difference:

- Raw material production (A1) has a share of more than 65% in both categories in the Portuguese results and this life cycle stage was modelled using the ELCD database (the most recent data set for this process). If other databases were used to model this process in the EPD, this may have caused the differences found (the EPD do not declare the database used, except the joint EPD that refers that raw material production was based on the literature);
- The manufacturing has a share between 18% (in PE-NRe) and 25% (in GWP) in these categories. In the Portuguese case, these impacts are mainly due to the burning of naphtha in the boiler (e.g. 87% in GWP) to generate steam for the foaming process, which can be considered an "old" technology taking into account the age of this plant and of the equipment used in this process. Although no data is available in the EPD concerning the fuels or the processes used to generate steam for foaming, it is probable that a more recent technology can have an improved efficiency both in terms of naphtha (or other non-renewable fuel) consumption and greenhouse gas emissions.

Concerning POCP, EPD present figures between 59% and 187% higher than the Portuguese results. POCP are, in the Portuguese study, mainly (90%) caused by pentane and isopentane release during manufacturing. Due to the lack of site specific data concerning the percentage of the blowing agents that are released during this stage, a value of 30% was considered for the quantity initially included in PE expandable granulate that is freely released to the atmosphere during the gate-to-gate stage. This value was based on the Ecoinvent process for EPS (which was not included in this comparison because it corresponds to a board with twice the density of the one produced in Portugal) because the EPD do not quantify this percentage, despite referring to it. Therefore, it is probable that the EPD consider a

higher percentage of blowing agents released during the manufacturing stage.

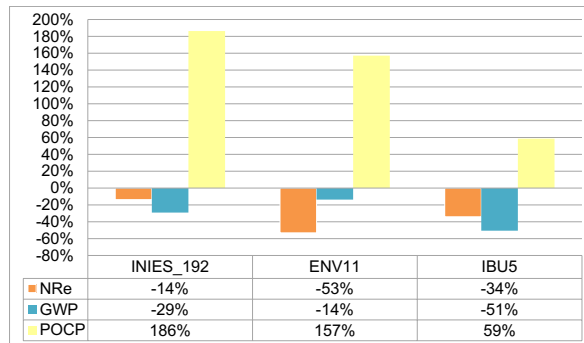

Fig. 5: Differences in PE-NRe, GWP, and POCP for EPS boards (A1-A3) with the same thermal performance between individual (INIES and ENV) and joint (IBU) EPD and Portuguese site specific data.

Benchmarking of Portuguese results for EPS production was important to verify the validity and check the plausibility of this LCA study. Despite the lack of detailed data concerning the technology for EPS production represented in each EPD, and the assumptions made concerning the release of the blowing agent during this stage, it can be considered that the results achieved for the Portuguese case study are plausible and can be used in LCA of building assemblies in the Portuguese context.

### 3.4 Polyurethane/Polyisocyanurate (PUR/PIR)

In this case, 1 joint EPD (from the German system, including 8 companies), 1 European average (from PU-Europe) and 2 generic (1 from Ecoinvent and another one from Plastics Europe, both not including the packaging of the boards) data sets are available for PUR/PIR boards with characteristics similar to the ones studied. A European REVA was not calculated because the European average data set does not refer to the number of companies included in the corresponding LCA study.

The results for the Product stage (A1-A3, not including the packaging material) of PUR/PIR boards produced in Portugal [2] were compared with the ones included in the referred data sets, and the relative differences found for three impact categories are presented in Figure 6. Figure 7 shows a similar comparison, but only including the European average data set and the joint EPD because generic data sets do not refer to the density or the thermal conductivity of the boards studied. This comparison was made considering the same thermal performance for the PUR/PIR boards represented by each data set (similarly to the XPS case study).

The results from the Portuguese producer are very similar to generic data sets in NRe and in GWP (1-4% differences). However, the difference is higher in AP, generic data sets presenting an impact around 14% higher than Portuguese results. This difference can be explained by the higher content of isocyanate in the products considered in generic data sets (4% more, on average, when compared with Portuguese

boards). In fact, this component has a contribution of 78% to AP within raw materials, but a lower one for GWP (66%) and for NRe (62%).

Concerning the European average data set and the joint EPD (PUE and IBU in Figures 6 and 7, respectively), differences are not significant in the production of 1 kg of PUR/PIR boards for any environmental category relative to the Portuguese results (between 7% and 18%). These differences are even lower for NRe and AP when the comparison relies on the quantity of material necessary to achieve the same thermal performance (between 1% and 2%, which can be considered residual). This difference increases however in this second comparison for GWP, PUE and IBU presenting an impact 11% and 21% higher (respectively) to that of the Portuguese production. This increase is mainly explained by the better thermal performance (thermal conductivity 30% lower) of the PUR/PIR boards produced in Portugal.

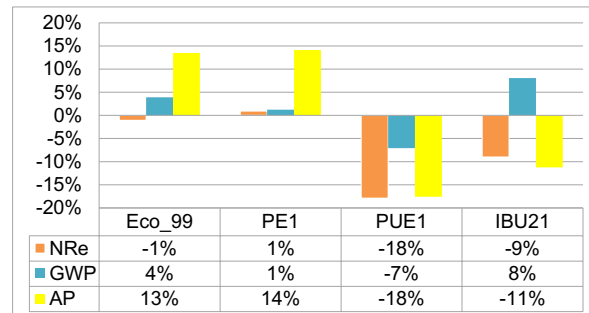

Fig. 6: Differences in PE-NRe, GWP, and AP: production of 1 kg of PUR boards (A1-A3, wtt packaging material) between Portuguese site specific data and generic (Eco and PE) and European average (PUE) data sets and joint EPD (IBU).

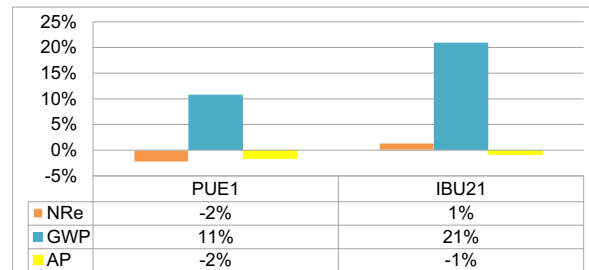

Fig. 7: Differences in PE-NRe, GWP, and AP: production of PUR boards (A1-A3, wtt packaging material) with the same thermal performance between Portuguese site specific data and a European average data set (PUE) and a joint EPD (IBU).

There is a higher similitude of the Portuguese figures with the European average data sets, which are based on the production of a higher number of companies than the other data sets and have a higher geographical representativeness. The plausibility of the Portuguese LCA study of the production of PUR/PIR boards was checked through a benchmarking with European data sets of similar products. Given the low significance of the differences found, it can be considered that the results

achieved for the Portuguese case study are plausible and can be used in LCA of building assemblies in the Portuguese context.

### 3.5 Insulation Cork Boards (ICB)

ICB (or Agglomerate of Expanded Cork) is an insulation material produced in Portugal and in some other countries around the world, Portugal being the world's largest producer and exporter.

As described in detail in two other papers [2; 3], there is yet no other complete LCA study available worldwide concerning this insulation material, neither is any environmental declaration. Therefore, the LCA results achieved for the ICB boards can be used for the LCA of building assemblies or buildings at an international level.

### 3.6 Stone Wool insulation boards (SW)

For the production of 1 kg of SW (uncoated, produced using a synthetic binder, without packaging) with an average density of 89.64 kg/m<sup>3</sup> and an average thermal conductivity of 0.04 W/(m.°C), a European REVA based on 7 individual EPD (6 French and 1 German) was considered (an arithmetic mean for each environmental indicator, since none of these datasets declare production volumes). This selection has been made after completing a data quality assessment to rank available datasets at the European level for this material. The results of this case study are described in detail in another paper [1].

## 4 CONCLUSION

NativeLCA relies on the selection of LCA data sets of construction materials (generic, average, EPD or site specific) available in Europe to be used as generic for a national context, after a comprehensive verification of their quality, consistency and representativeness (Figure 1). It is a straightforward approach; focused on the selection of a LCA data set to be used by practitioners depending on their goal and scope.

The six case studies presented in this paper demonstrate the applicability and usefulness of NativeLCA, namely in the selection of a coherent dataset as generic data within a national context. Moreover, the application of this methodology showed, in 4 of the case studies, its feasibility, benefits, and also some limitations and potential improvements, in the verification of the plausibility of LCA studies completed in Portugal based on site-specific data. The straightforwardness of its application was also proved, since it is not excessively time and resources demanding. This kind of scientifically-based aid to decision-making is very useful to LCA practitioners namely in EPD development or critical review.

The scope of NativeLCA was limited in this paper to insulation materials, but this methodology can be applied to other building products.

## 5 ACKNOWLEDGMENTS

The authors gratefully acknowledge the support of FCT (*Foundation for Science and Technology*) and of the CERIS Research Centre, Instituto Superior Técnico, Universidade de Lisboa, Portugal, and of the European Union, OP RDI project No. CZ.1.05/3.1.00/13.0283 - Intelligent Buildings. The CSTB acknowledges the financial support of the Industrial Chair Sustainable Buildings and Innovation funded by Bouygues Construction. Special thanks are due to the Portuguese manufacturers of insulation materials for providing the necessary data to complete this research work.

## 6 REFERENCES

1. Silvestre, J. D.; Lasvaux, S.; Hodkova, J.; de Brito, J.; Pinheiro, M. D., NativeLCA - a systematic approach for the selection of environmental datasets as generic data: application to construction products in a national context. *Int J Life Cycle Assess*, 2015. 20 (6): p. 731-50.
2. Pargana, N.; Pinheiro, M. D.; Silvestre, J. D.; de Brito, J., Comparative environmental life cycle assessment of thermal insulation materials of buildings. *ENERG BUILDINGS*, 2014. 82: p. 466-481.
3. Silvestre, J. D.; Pargana, N.; de Brito, J.; Pinheiro, M. D., Environmental Life Cycle Assessment from Cradle to Cradle of Insulation Cork Boards, in *Congresso Luso-Brasileiro de Materiais de Construção Sustentáveis (CLB-MCS 2014)*. 2014: Guimarães, Portugal. p. 89-101.



## Expanding Boundaries: Systems Thinking for the Built Environment

### €COFFICE-LCC AND LCA AS PART OF THE INTEGRATED DESIGN APPROACH FOR A HIGH PERFORMANCE-LOW COST OFFICE BUILDING

L. Delem<sup>1\*</sup>, R. Decuyper<sup>1</sup>, O. Dartevelle<sup>2</sup>

<sup>1</sup> Belgian Building Research Institute, Belgium

<sup>2</sup> Architecture et Climat, Université catholique de Louvain, Belgium

\*Corresponding author; e-mail: laetitia.delem@bbri.be

#### Abstract

The main objective of the BTP1000 project was to design (and build) an office building (€coffice) that would comply to the PassivHaus principles, offer a very high comfort and integrate different sustainability features, but cost no more than a traditional building. In order to achieve those objectives, an integrated iterative design approach was followed. From the beginning of the project, all stakeholders and various building specialists contributed to the decision making process, and design alternatives were evaluated from various perspectives (e.g. energy performance, comfort, life cycle cost and impact, etc.).

The present paper focuses on how life cycle analysis (LCA) and life cycle costing (LCC) were used to integrate environmental and economic dimensions in the design process of the building envelope and how the results influenced final design options. LCA and LCC studies first compared different types of façades. The best compromise between LCC and LCA results, practical implementation, and thermal comfort were then selected for implementation. Subsequently, parametric energetic simulation results (combining heating, cooling, lighting, and ventilation) were used as input for LCA and LCC studies in order to optimise the insulation level of the building fabric elements (outer walls, roof, ground floor, glazing). In conclusion, LCC and LCA were very useful in the integrated design process and results showed the importance of taking into account not only the energy use for heating and cooling, but also for lighting into the building fabric optimisation.

#### Keywords:

Integrated design, Life cycle costing, Life cycle analysis, sustainability, optimisation, building envelope

## 1 INTRODUCTION

The €coffice building, which was completed in 2013, is the result of the BTP1000 research project. BTP1000 had as main objective to design (and build) an office building (€coffice) that would comply to the Passive House standard, offer a very high level of visual and thermal comfort and integrate different aspects of sustainable building design (e.g. low water use, biodiversity on site, reduced environmental impact, etc.), but cost no more than a traditional office building. Moreover, the design had to be reproducible, flexible and polyvalent.

To achieve those objectives, all stakeholders and various building experts were involved from the

beginning of the project in the iterative design process, trying to find the best compromises between functional constraints, energetic performance, sustainability aspects, and financial considerations.

Subjects for optimisation were for example the implementation on the building site, building shape, window openings, materials and building installations [1], insulation level, etc.

Life cycle analysis (LCA) and Life cycle costing (LCC) were used all along the project to integrate environmental and financial considerations into the decision making process and to evaluate at the end of the project the as-built performance of the building [2]. The present paper; however, focuses on how LCC and LCA influenced the

materials selection and insulation level of the building fabric elements.



Fig. 1: €coffice (<http://www.€coffice-building.be/>).

## 2 DATA AND METHODS

### 2.1 Life Cycle Analysis

From an environmental point of view, as the building owner was seeking a BREEAM certification, the “Green guide to specification” was partly used for material selection. However, for the optimisation of the envelope (composition and insulation level) and the as-built evaluation of the building a detailed LCA study was done, using the SimaPro software with Life cycle inventory data from the ecoinvent database v2.2 and gate-to-grave scenarios (e.g. transport and end-of-life of building materials) which are representative for Belgium [3]. Allocation principles and system boundaries were set according to EN 15978 [4]. However, during the design phase, as results needed to be usable for decision making, the ReCiPe life cycle impact assessment method [5] was used instead of the 7 impact indicators from the EN 15978. Indeed, the 18 midpoint ReCiPe indicators can be aggregated into a single score, which greatly facilitates interpretation. A disadvantage of the single score is that it is less robust (uncertainty related to the use of endpoint indicators) and more subjective (value-based weighing factors).

### 2.2 Life Cycle Costing

The LCC analyses followed the general principles of the ISO 15686-5 standard.

Data for building component service lives, frequencies and costs of maintenance activities were based on national and international sources [6], [7] and databases [8], [9].

The Net Present Value (NPV) was used as main LCC-indicator. NPV is the summation of all the discounted costs during the **reference study period (RSP)**, and provides a one-figure indicator that facilitates the comparison between different alternatives. A nominal discount rate of 3.5% and an inflation rate of 2.5% were assumed.

## 3 COMPOSITION OF THE OUTER WALLS

In order to optimise the material selection for the outer walls, different wall compositions with similar U-values (see Table 1, LF=light façade, MF=massive façade) were proposed by the architect (A2M). Those alternatives were then analysed using LCA and LCC, for a RSP of both 30 and 60 years.

For the 30-years analysis, no replacements of materials were considered. For the 60-year LCA assessment 2 alternative scenarios were analysed. The minimum replacement scenario supposed that when the rendering (alternatives LF2, LF3, MF2) or exterior panels (LF1, MF1) are replaced the underlying insulation can be preserved, while the maximum replacement scenario considered that the underlying insulation is replaced as well.

### 3.1 Results

Fig. 2 presents the LCC results for the RSP period of 30 years (from an investors point of view the most relevant RSP of both). Fig. 3 presents the LCA results (expressed in ReCiPe single score points) for different RSP and replacement scenarios.

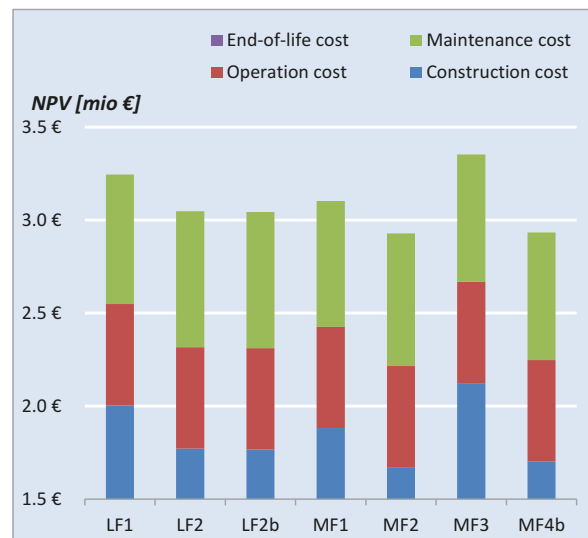

Fig. 2: LCC results for different façade variants.

### 3.2 Discussion

The LCA (and LCC) results show that independently of the RSP and replacement scenario considered, the light façades (LF) do not systematically have a better score than the massive façades (MF). Also, both from an environmental and financial point of view MF2 and MF4b are relatively interesting. MF4b is particularly interesting when considering a 60 year RSP and the maximum replacement scenario. Indeed, unlike the alternatives with rendering or fibre cement panels, the brick façade does not need to be replaced within the considered RSP. Note that the alternative MF4b was not part of the initial proposition made by the architect, but composed following the discussion



of the preliminary LCA results (which showed the interest of using bricks as outer façade but also the high impact of a massif concrete wall compared to hollow concrete blocks). As the LCC study was completed following the LCA study, it did not consider FM4.

Considering the relatively good environmental performance of MF2 and MF4b, the fact that the

contractor was more familiar with massive constructions, and the positive influence of the massive walls on summer comfort and the energy use for cooling (based on dynamic energy simulations), those alternatives were finally implemented (MF2 on the North and South and MF4b on the East and West oriented walls).

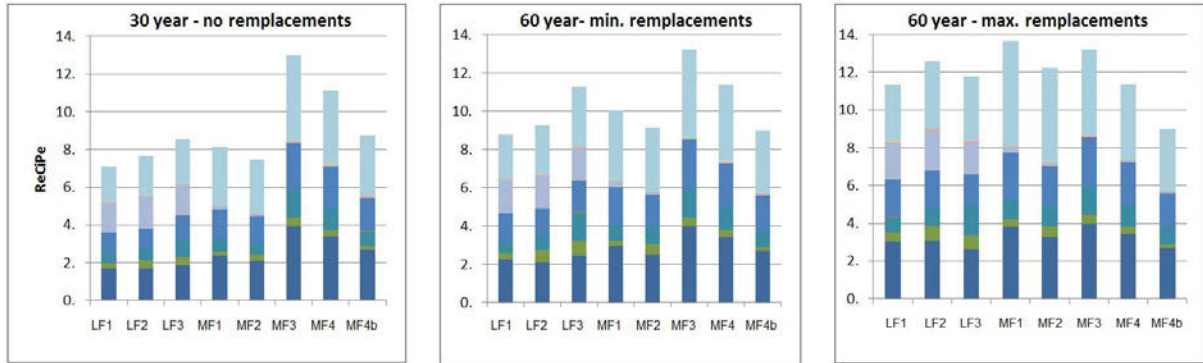

Fig. 3: LCA results (ReCiPe score) for different façade variants, RSP and replacement scenarios.

<b>Light façade 1</b> (LF1)		<b>Structure</b> Wooden l-joists <b>Insulation</b> Cellulose (30cm) <b>External finish</b> Fibre cement panels <b>Internal finish</b> Gypsum blocks (10cm)
<b>Light façade 2</b> (LF2)		<b>Structure</b> Wooden l-joists <b>Insulation</b> Cellulose (25cm) + woodfibre panels (8cm) <b>External finish</b> Plaster <b>Internal finish</b> Gypsum blocks (10cm)
<b>Light façade 3</b> (LF3)		<b>Structure</b> Wooden l-joists <b>Insulation</b> Cellulose (25cm) + woodfibre panels (8cm) <b>External finish</b> Plaster <b>Internal finish</b> Gypsum blocks (10cm)
<b>Massive façade 1</b> (MF1)		<b>Structure</b> Hollow concrete blocks (14cm) <b>Insulation</b> EPS (30cm) <b>External finish</b> Cement fibre boards <b>Internal finish</b> Plaster
<b>Massive façade 2</b> (MF2)		<b>Structure</b> Hollow concrete blocks <b>Insulation</b> EPS (30cm) <b>External finish</b> Rendering <b>Internal finish</b> Plaster
<b>Massive façade 3</b> (MF3)		<b>Structure</b> Concrete curtainwall <b>Insulation</b> EPS (30cm) <b>External finish</b> Architectural concrete panels <b>Internal finish</b> Plaster
<b>Massive façade 4</b> (MF4)		<b>Structure</b> Concrete curtainwall <b>Insulation</b> EPS (30cm) <b>External finish</b> Concrete masonry <b>Internal finish</b> Plaster
<b>Massive façade 4b</b> (MF4b)		<b>Structure</b> Hollow concrete blocks <b>Insulation</b> EPS (30cm) <b>External finish</b> Concrete masonry <b>Internal finish</b> Plaster

Table 1: Alternative wall compositions.

#### 4 INSULATION LEVEL OF THE BUILDING FABRIC

Parametric energetic simulations (TRNsys 17 software [10]) showed that insulating the €coffice building (given layout, orientation, etc.) *beyond* the Passive House criteria of 15kWh/m<sup>2</sup> net energy consumption for heating would have a positive effect on the total energy consumption (sum of heating and cooling) of the building. However, considering that passive cooling strategies were in place (e.g. possibility to open windows during night time) no optimum (maximum) insulation level could be observed (within practically implementable thicknesses). Moreover, given the high compactness of the building (C=2.9) and its relatively high internal gains resulting from its use as office space, results also indicated that the 15kWh/m<sup>2</sup> requirement could be met with double glazed windows and insulation levels for the building fabric elements close to the Energy performance of buildings directive (EPBD) requirements that were in place in the Walloon region at that time (U-value of the ground floor and wall ≤ 0.4 W/m<sup>2</sup>K and U-value of the roof ≤ 0.3 W/m<sup>2</sup>K).

##### 4.1 Global insulation level

As optimal insulation levels and the choice of glazing could not be derived solely based on energetic considerations, LCA and LCC studies were executed to compare different global levels of insulation of the building fabric (U-value of outer walls, roofs and ground floor) in the case double glazing (U=1.1 W/m<sup>2</sup>K, g=0.609) or triple glazing (U=0.59 W/m<sup>2</sup>K, g=0.584) would be used, and passive cooling would (not) be allowed. Those studies considered the life cycle impact (cost) of the relevant materials, and the energy use for heating (gas) and cooling (electricity) for a RSP of 30 years.

The following insulation materials were considered (selected based on environmental, financial and practical considerations):

- EPS (expanded polystyrene) for the walls:  $\lambda=0.032\text{W/mK}$
- In-situ blown PUR (polyurethane) for the ground floor ( $\lambda=0.028\text{W/mK}$ )
- PUR plates for the (flat) roof ( $\lambda=0.026\text{W/mK}$ )

The results from those studies (which are not presented in detail here) showed that, unlike the energetic simulations results, LCC and LCA results enabled to identify an optimal global insulation level, even when passive cooling was allowed. However, the optimum U-value was lower with double glazing and natural ventilation. Also the optimum U-value based on LCA was systematically lower than the LCC optimum (see figure x considering the possibility to open windows at night, the LCA and LCC optimum

when using double glazing were respectively 0.15 and 0.2 W/m<sup>2</sup>K).

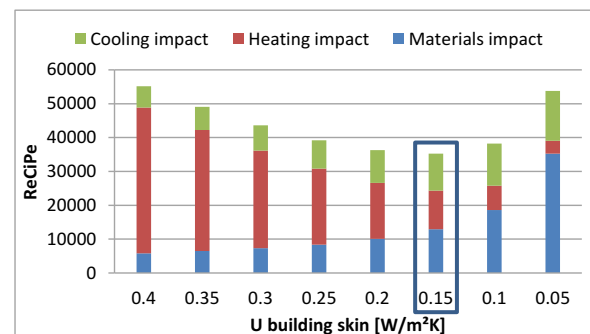

Fig. 4: Optimum insulation level based on LCA results (with passive cooling and double glazing).

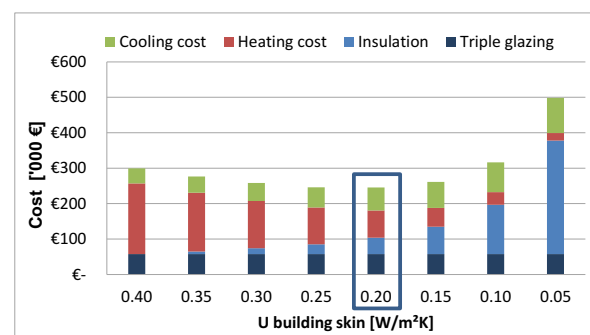

Fig. 5: Optimum insulation level based on LCC results (with passive cooling and double glazing).

##### 4.2 Double or triple glazing

In order to enable a well-founded choice, the double and triple glazing alternatives were further analysed but this time also considering the energy use for lighting (see Table 2). Also, as from above studies the optimum insulation level seemed to be higher when using double glazing compared to triple glazing, both alternatives were defined such as to achieve a similar net energy use for heating (+10kWh/m<sup>2</sup> based on PHPP calculation), resulting in a higher global insulation level ( $U_{\text{fabric}}=0.12\text{W/m}^2\text{K}$ ) for the double glazing alternative compared to the triple glazing alternative ( $U_{\text{fabric}}=0.25\text{W/m}^2\text{K}$ ).

Again a reference study period (RSP) of 30 years was used for both analyses as the glazing would probably be replaced after 30 years and some insulation possibly too. In addition, a sensitivity analysis was performed for the LCA analysis based on a 60 year RSP and different replacement scenarios for the insulation (cfr. outer wall study)

	Net Energy use (kWh/m <sup>2</sup> ) for		
	Heating	cooling	Lighting
Triple glazing $U_{\text{fabric}}=0.25\text{W}/\text{m}^2\text{K}$	13.16	1.17	21.05
Double glazing $U_{\text{fabric}}=0.12\text{W}/\text{m}^2\text{K}$	12.27	1.26	19.55

Table 2: Net energy use (calculated with Transys) for different compositions of glazing and insulation.

## Results

Fig. 6 shows the results from the LCA (ReCiPe score) and LCC analysis for a RSP of 30 years.

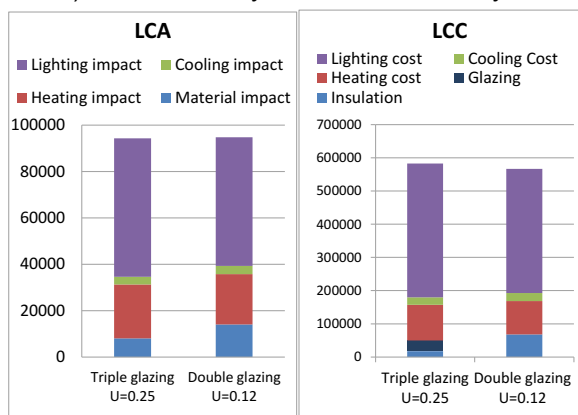

Fig. 6: LCA and LCC results for the triple vs. double glazing analysis for a RSP of 30 years.

## Discussion

From an environmental point of view there is no significant difference between the life cycle impact of the option “double glazing with higher insulation levels (Double glazing +  $U=0.12$ )” or “triple glazing with lower insulation levels (Triple glazing +  $U=0.25$ )”. Indeed, the first option has a slightly higher material impact (life cycle impact of glazing + insulation) but this is compensated by the resulting gains in energy use for lighting (better light transmission of double glazing). For a RSP of 60 years and considering that, unlike the glazing, the insulation does not need to be replaced within the considered timeframe, the alternative with double glazing becomes slightly more interesting (3%) than the alternative with triple glazing as the additional impact from insulation can be amortized over a longer time period, but the difference is still insignificant.

Concerning the LCC results, the additional investment cost for getting from an insulation level of  $U=0.25\text{W}/\text{m}^2\text{K}$  to  $U=0.12\text{W}/\text{m}^2\text{K}$  exceeds the difference in cost between triple and double glazing. However, the double glazing alternative achieved a lower heating energy consumption and a far lower lighting energy consumption. Consequently, even with a slightly higher energy

consumption for cooling, this scenario obtained a lower overall NPV.

Finally, as results from thermal comfort simulations (according to NEN 15251 and ISO7730) showed that the alternative with triple glazing resulted in 10% more time in comfort 1 zone on the north side, it is a combination of glazing that was selected for the final design, namely triple glazing on the north side and double glazing on the south side. A post-construction LCC analysis considering the individually optimised insulation levels determined in next section supported this decision.

## 4.3 Optimisation of the insulation level of the individual building elements.

The next step consisted in the individual optimisation of the U-value of the various building elements. Therefore, parametric energy simulations calculated the energy use for heating of the building for varying U-values of each element (from EPBD requirements to realistically high insulation levels), supposing that the other elements were insulated to the applicable EPBD requirements. Those results were then used as input for LCA and LCC.

For each element, the LCA considered a RSP of 60 years. In cases where the service life of the insulation was possibly shorter, alternative RSP were also considered (e.g. for the flat roof insulation the calculations were done for a RSP of 30 and 60 years). On the other hand, the LCC study was also carried out for different RSP's, but a RSP of 30 years was finally considered to be the most relevant for decision making (investors preference). So only those results are presented here.

## Results

Fig. 7 and Fig. 8 show the detailed results from the LCA and LCC study of the roof insulation for a RSP of 30 years. Table 3 summarises the optimum insulation levels, identified based on LCA and LCC results, for the various building fabric elements (and RSP's). Insulation thicknesses selected for implementation are also mentioned in that table.

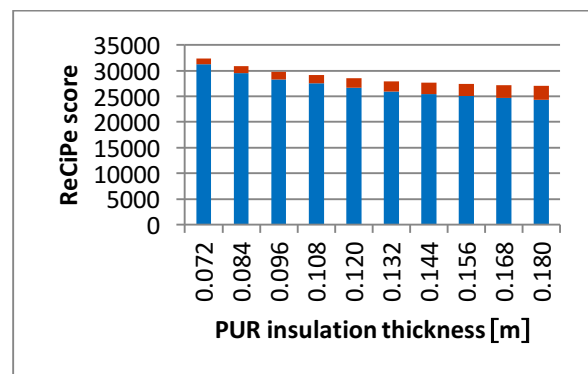

Fig. 7: LCA results for varying roof insulation thicknesses.

### Discussion

Fig. 7 shows that from an environmental point of view no optimum insulation level was reached for the flat roof within the analysed insulation thicknesses (max. 18cm PUR). However, as was the case for the other elements where LCA results did not lead to an absolute optimum, the marginal environmental gains between the higher insulation thicknesses are relatively small (see Fig. 7 the curve is almost horizontal at the end). On the other hand, the LCC results presented in Fig. 8 indicate that, the optimum insulation thickness for a return on investment of 30 years is 13cm for the flat roof. Finally, seen the relatively low environmental benefit from insulating beyond the LCC optima, 15cm insulation was placed on the flat roof.

For the same reasons, the LCC optima for a return on investment period of 30 years were finally also selected for various other elements as final design option. One exception was the ground floor, where the absolute economic optimum was chosen (return on investment of 60

years) instead of the 30 year return period. The reasons therefore were the fact that an LCA optimum was reached (17cm), the investment cost of extra insulation was relatively low, and the expected life time of the insulation would most probably be higher than 30 years.

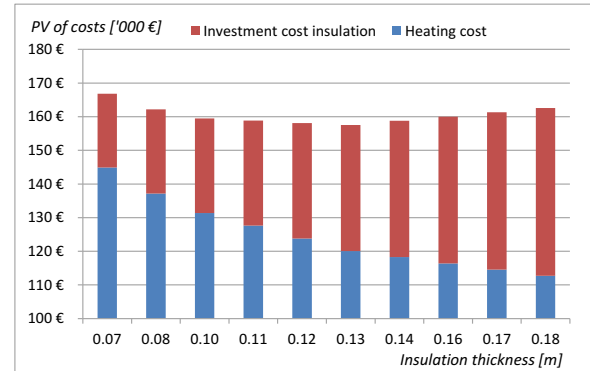

Fig. 8: LCC results for varying roof insulation thicknesses.

Element	Insulation	LCA		LCC	Final design
		RSP (years)	Optimum thickness	Practical economic optimum (30 years)	
Wall (N)	EPS	40 60	≥30 cm	17.6cm	18cm
Wall (S)	EPS	40 60	≥30 cm	17.6cm	18cm
Wall (E)	EPS	40 60	≥30 cm	17.6cm	18cm
Wall (W)	EPS	40 60	26 cm	17.6cm	18cm
Wall in ground	EPS	60		12.9cm	18cm
Roof	PUR	60 30	≥18 cm ≥18 cm	13.2cm	15cm
Floor	In-situ PUR	60	16.5 cm	<9cm	15cm

Table 3: Optimum insulation levels of building fabric elements, based on LCA and LCC results.

## 5 GENERAL CONCLUSIONS

The €coffice case study showed that performing LCA and LCC studies at various moments within the project development effectively enables to integrate life cycle environmental and financial considerations into the decision making process and to influence final design options. However, LCA and LCC do not always lead to the same results and are only truly useful for decision making when interpreted in combination with other considerations (e.g. budget, practical implementation, comfort, etc.).

## 6 ACKNOWLEDGMENTS

The authors thank the project partners for providing detailed information. The BTP1000 research project was funded by the Walloon Region.

## 7 REFERENCES

1. Van Moeseke, G.; Darteville, O.; Deltour, "€coffice–HVAC solutions for passive offices," *Passive. House Symposium. 2011*, 2011.
2. Delem, L., Wastiels, L. and Van Dessel, J. "Assessing the construction phase in building life cycle assessment," *Proceedings of LCA Conference 2013, avniR, Lille, November 4-5*, 2013, no. 1.
3. Delem, L., Van Dessel, J., et al., "Environmental Profile of Building elements," 2013.
4. European Committee for Standardisation, *EN 15978:2011 - Sustainability of construction works - Assessment of environmental performance of buildings - Calculation method*. 2012.
5. Goedkoop, M.; Heijungs, R., et al., "ReCiPe 2008," 2009.
6. Albano, J.-R., *La Maintenance des Bâtiments en 250 Fiches Pratiques*, 2nd ed. Paris: Le Moniteur, 2005.
7. WTCB, *Onderhoudsgids voor duurzame gebouwen*, WTCB, 2011.
8. BIM Media, "Beheer- en onderhoudskosten." Doetinchem.
9. RICS, "Building Running Costs Online." RICS, London.
10. M. University of Wisconsin, "Solar Energy Laboratory, TRNSYS: A Transient Simulation Program." 2013.





## Expanding Boundaries: Systems Thinking for the Built Environment

### SUSTAINABLE STEPWISE BUILDING RENOVATION

M. Lehmann<sup>1\*</sup>, W. Ott<sup>2</sup>

<sup>1</sup> econcept AG, Gerechtigkeitsgasse 20, CH-8002 Zürich, Switzerland

<sup>2</sup> econcept AG, Gerechtigkeitsgasse 20, CH-8002 Zürich, Switzerland

\*Corresponding author; e-mail: meta.lehmann@econcept.ch

#### Abstract

Based on current renovation activities in single-family and multi-family buildings in Switzerland, the relevance and the drivers of stepwise building renovation in Switzerland are shown. The obstacles to more comprehensive energy related renovation measures as well as to planning for a longer term of phased renovation measures are highlighted. The analyses of the drivers for and the shortcomings and advantages of phased building renovation are summarized in a SWOT analysis of stepwise building renovation. Based on the advantages of phased building renovation it was explored how stepwise building renovation can be carried out sustainably, meeting ambitious energy demand and greenhouse gas reduction targets in the longer term. Policy measures for making stepwise building renovation more sustainable and achieving existing energy and greenhouse gas related targets are identified.

#### Keywords:

Building Renovation, Sustainability, Green House Gas Emission Reduction, Energy Conservation, Subsidy Programs, Building Strategy

### 1 INTRODUCTION

The renovation of the building stock is a major field of action for sustainable development, energy and climate policy. While the European research community, promoters and policy makers in the field of building renovation (e.g. approach of the EPBD - Energy Performance of Buildings Directive) usually assume that building renovation towards nearly zero energy buildings is realized by rather comprehensive packages of energy related renovation measures, real life reveals that most renovation projects focus on urgent problems, having a limited scope. Hence, current building renovation projects often tend to be carried out stepwise, spread across a relatively long period of time. Too often they fall short of fully tapping the potential for reducing non-renewable energy demand and greenhouse gas (GHG) emissions which would be necessary to meet the targets set by the energy and climate policy.

For the Swiss Federal Office of Energy (SFOE) it was investigated how buildings are currently renovated, why stepwise renovation is in the majority of cases the renovation strategy of choice and whether current renovation in small

steps will meet existing long term energy and GHG emission reduction targets [1]. Attempts were made to come up with recommendations on how to meet existing sustainability targets while renovating in steps.

### 2 METHODS

The research was based on a multidimensional approach: First the literature was analysed for an overview on observed renovation strategies, obstacles for and drivers of stepwise building renovation. Second 14 experts and practitioners in the field of building renovation (building professionals, architects, energy consultants, investors, representatives of associations, researchers) were interviewed with a focus on shortcomings and advantages of stepwise building renovation and how to assure this renovation type to be executed in a sustainable way. Third a web-survey among home owners was carried out. Fourth the effect of different renovation packages on costs, GHG emissions and non-renewable energy demand for two generic buildings was calculated. The assessment also addressed the effect of spreading the package over a longer period of

time. The findings and conclusions are presented in a SWOT matrix, a synthesis of the results and recommendations for policy measures.

### 3 TARGETS FOR BUILDING RENOVATION

Long term energy and CO<sub>2</sub> emission targets for the Swiss building sector are defined by the "SIA Energy Efficiency Pathway" [2] of the Swiss Society of Engineers and Architects (SIA). The targets are set for non-renewable primary energy use, GHG emissions and the limit value for heating requirements, as per SIA 380/1, of buildings. These targets correspond to the long term targets of the SFOE and the 2000-Watt-Society (see subsequent Table 1).

Besides the energy and GHG targets there are further objectives to be considered in building renovation:

- Densification (spatial planning)
- Maintenance of cheap housing (social policy)
- Minimize harassment of building users (social policy)
- Preserve historical buildings and the townscape

Residential buildings	Primary energy [MJ/a·m <sup>2</sup> ]		GHG emissions [kg CO <sub>2eq</sub> /a·m <sup>2</sup> ]	
	New	Retrofit	New	Retrofit
<b>Reference values</b>				
Construction	110	60	8.5	5.0
Operation	200	250	2.5	5.0
Mobility	130	130	5.5	5.5
<b>Target values</b> (construction+ operation+mobility)	440		16.5	15.5

Table 1: Overall target values and reference values for primary energy use and GHG emissions for building construction, building operation and building related mobility needs according to the SIA Energy Efficiency Pathway [2].

### 4 BUILDING RENOVATION TODAY

We distinguish the following categories of building renewal:

- Restoration without energy efficiency improvements (only functional restoration for another renovation cycle)
- Energy related renovation (renewal striving also for energy efficiency improvements)
- Comprehensive refurbishment: Complete renewal, comprising also energy efficiency related improvements

- Partial renewal, limited to certain building elements, with or without energy efficiency related improvements

69% - 71% of Swiss residential buildings are renovated continuously or stepwise, 16% - 17% are only maintained and only 7% (single family buildings - SFB) to 12% (multifamily buildings - MFB) are comprehensively refurbished [3].

Period: 2001-2010	Restoration without energetic improvements		Energy related renovation	
	SFB [% /a]	MFB [% /a]	SFB [% /a]	MFB [% /a]
Windows	1.1	0.5	2.1	3.0
Façade	1.8	1.6	0.6	0.7
Pitched roof	0.4	0.5	1.2	1.5
Cellar ceiling	0.2	0.1	0.4	0.9

Table 2: Annual renovation activities per envelope element during the evaluation period from 2001-2010 for Swiss residential buildings built before 1990 (% of envelope area per year). SFB: Single family buildings; MFB: Multifamily buildings (source: [4]).

An earlier survey on the renovation behaviour for SFB [5] discloses that 82% of SFB renovations are carried out without previously elaborating a comprehensive long term concept or strategy. For MFB [6] a survey showed that in only 8% of the cases renovation measures are embedded in a long term planning scheme.

While in case of a building renewal 66% - 90% of the windows, pitched roofs and cellar ceilings are energetically improved, only 25% - 30% of the façades renewed are energetically improved. This will make it difficult to achieve current energy targets.

### 5 DRIVERS AND OBSTACLES

The review of the literature, available surveys regarding building renovation in Switzerland and the interviews with 14 experts and practitioners yield the subsequent main drivers of stepwise renovation and obstacles to sustainable phased building renovation.

#### 5.1 Drivers of stepwise renovation

Particularly private non-professional building owners phase renovation measures for the following reasons:

- Ability to match financial resources and costs of chosen renovation measures. Very often it is presupposed that building renovation is financed with available liquidity to prevent borrowing [3, 7, 8, 9].
- Attempt to maintain affordable rents and current tenancies. Staggered rent increases



can be heard better and tenancies are maintained more easily [7].

- Desire to take maximum advantage of tax deductions of expenses for building maintenance and energy related renovation measures [10].
- Risk aversion due to uncertainty as to the future marketability of the building, needs of the users, energy price developments, development of costs, reliability and durability of new technologies, etc. [11, 12].
- Circumvention of building regulations which require costly modifications on the existing building once it is necessary to apply for a building permit. More comprehensive renovation projects have to apply for a building permit. In this process it is usually checked if the building complies with all of the existing building regulations after having carried out the renovation, i.e. also with regulations which didn't exist at the time the building was erected (like new fire protection regulations, etc.) [7].
- Phased renovation allows for replacing only building elements which have reached the end of their service life (fewer sunk costs for too early replacement within a comprehensive renovation project) [7, 9].
- Chance to make use of more advanced technical solutions and to adapt to changed user needs in subsequent phases of building renovation.

## 5.2 Obstacles to sustainable phased building renovation

In principle, in the majority of the cases phased building renovation could be sustainable and meet existing and upcoming energy and GHG targets. But sustainable stepwise renovation is demanding and needs integral planning, comprising the different steps of the overall renovation process. The following main obstacles to sustainable phased building renovation were identified:

- As was previously shown, 80% - 90% of building renovations are not based on a medium to long term strategy for the building and are not integrally planned for all of the upcoming phases of the renovation process [3, 5, 6, 13].
- Usually there is no setting of final targets which are supposed to be achieved at the end of the renovation process taking place in several steps [6]. Therefore, the first steps risk to be too short sighted and not embedded in a long term strategy.
- Costs for developing a strategy and for initial integral planning are an important obstacle [7]. They hinder carrying out this essential

preparatory work, resulting often in sub-optimal solutions or follow-up costs, if ambitious targets still are to be achieved.

- The incentives for architects and planners are not strong enough to make them promote actively initial strategy development and integral planning of several steps of building renovation. In general, they have the know-how and could be the promoters of these issues.

## 6 BEHAVIOUR OF BUILDING OWNERS

The decision making behaviour of residential building owners with respect to building renovation was investigated by a web-survey. 1'686 building owners from the subsequent data bases were contacted, about half of them from SFB and MFB respectively. 288 owners filled in the questionnaire from which 263 questionnaires were complete (16%), 147 from MFB and 116 from SFB:

- Database of "Baublatt Infodienst": 886 addresses of residential building owners in the cantons of Basel-Stadt, Bern, Schaffhausen and Thurgau, who have applied recently for a building renovation permit.
- Database of "Hausverein Zürich", which is an association of building owners who are committed to the principles of fairness and ecological awareness: 800 addresses of residential building owners in the canton of Zürich.

50% of responding owners phase their building renovation, pursuing one of the three following strategies: "investing a fixed sum per year", "investing according to immediate needs" or "now and then a smaller partial renovation".

Almost two thirds of the respondents have already some kind of an energy concept, a concept for building renewal or a building strategy and 18% have a building energy certificate (GEAK).

Long term planning happens more often in the case of more comprehensive renovation attempts.

About 50% of the façades which have been renewed have not been enhanced in energy efficiency. 27% of the respondents renewing the façade without increasing energy performance indicated, that energy related improvements haven't even been an issue in planning and commissioning the façade renewal. 30% of respondents renewing the façade without improving energy performance referred to lacking financial liquidity or insufficient profitability or problems to pass incurring additional costs on the renters as a reason to turn down façade insulation.

33% of the buildings have an oil heating system and 34% a gas heating system. 30% of the buildings with fossil heating systems will have to replace their heating system during the next 10 years. Half of these systems shall be replaced by a fossil system again. Most mentioned alternative to fossil is a heat pump system.

## 7 PHASED RENOVATION SWOT-ANALYSIS

Phased building renovation is not necessarily unsustainable. Several aspects might even be

more sustainable than far reaching comprehensive building renovation in one step: e.g. economic viability, social compatibility and sustainability, embodied energy use.

A risk of (unplanned) small steps of renovation measures is that they tend to be only repairing or replacing building elements without tapping the potential of improving ecological standards and upgrading building quality.

<p><b>Strengths</b></p> <ul style="list-style-type: none"> <li>• Full life time of building elements is exploited (reduces costs and embodied energy use)</li> <li>• Adapting the scope of a renovation step to the available financial resources of the owner</li> <li>• Necessary rent increases can be staggered, no need to terminate existing tenancies</li> <li>• Renovation possible while building inhabited</li> <li>• No need to involve authorities and to comply with all existing building regulations if individual partial steps do not require approval or if the associated impact is low</li> <li>• Effect of tax deductions more pronounced if distributed across different periods</li> </ul>	<p><b>Weaknesses</b></p> <ul style="list-style-type: none"> <li>• Most owners renovating in steps do not consider to base the renovation steps on a long term concept, benefitting from synergies and avoiding adjustment costs</li> <li>• Smaller renovation projects requiring no planning permission may sometimes fail to comply with statutory minimum energy standards (can be difficult to verify)</li> <li>• Components with only minimal new insulation lead to excessive energy consumption over the years but will still be too new to warrant replacement for quite some time</li> <li>• Fewer opportunities to contribute to any improvement of the local district</li> </ul>
<p><b>Opportunities</b></p> <ul style="list-style-type: none"> <li>• If the phasing of a renovation project is based on a long-term overall concept, the level of energy standards associated with an overall renovation programme can be achieved</li> <li>• Some aspects of phased renovation can be more sustainable than other strategies: Embodied energy use, social compatibility, preservation of good architecture, etc.</li> <li>• Lower-income households find it easier to fund projects which are carried out in steps</li> </ul>	<p><b>Threats</b></p> <ul style="list-style-type: none"> <li>• Without any overall concept missing of synergies and optimizing potentials as regards costs, energy savings, comfort, etc.</li> <li>• Problems in terms of bringing things together (because of a failure to coordinate measures properly) lead to compromise solutions to energy and aesthetic issues and/or follow-up costs</li> <li>• Risk of problems with building physics (particularly mould)</li> <li>• Risk of patchwork buildings with poor architecture, not contributing to the image of the surrounding district.</li> </ul>

Table 3 Matrix with the SWOT-analysis for stepwise building renovation.

The above Table 3 summarizes the main strengths, opportunities, weaknesses and threats of phased building renovation according to the findings of the project, combining the perspectives of policy makers and private home owners.

## 8 HOW TO ENSURE SUSTAINABLE PHASED RENOVATION – MEASURES

Subsequent measures can contribute to improve sustainability of phased building renovation and increase the chance that stepwise renovations achieve ambitious long term energy conservation and GHG emission reduction targets after having carried out the last renovation step.

- Greater financial support for elaborating analyses and concepts for sustainable mid to long term building renovation. These concepts have to comprise several renovation phases and define the target which has to be achieved after the final renovation step. Building development strategies and renovation concepts for the longer term are considered to be a crucial prerequisite for far reaching and economic viable sustainable building renovation in phases.
- Amendment of subsidy programs for energy related building renovation: Subsidies for energy related renovation measures are only granted if subsidized measures are based on an overall renovation concept for the next 15 years (e.g. GEAK Plus with amendments), indicating future renovation steps within this period. This shall make sure that for the current measures carried out an overall concept for the longer term has been drafted.
- Continuous information campaign addressing building owners, architects, planners and craftsmen is recommended to raise awareness for the need and the benefits of comprehensive planning of building renovation for the longer term.
- Promotion and support of training and further education for renovation professionals, architects and planners with respect to consulting in building development strategies, energy related renovation strategies and energy certification. It should address phased building renovation processes and point out potential benefits and pitfalls.
- Simplified building approval procedures for energy related renovation measures to prevent complete approval procedures which might require costly and extensive measures to fulfil all of the requirements of present building regulation.
- The firms and craftsmen carrying out the work should be more in tune with initiatives involving public bodies and any objectives pursued through the energy and climate policy.
- Distinct efforts are required to increase façade insulation in case of building renovation, e.g. significant higher subsidies for façade insulation, clearly depending on the level of insulation.

## 9 CONCLUDING REMARKS

It is a matter of fact that a majority of building renovation projects is carried out in phases. Our analyses show that phased renovation risks falling short of existing targets for sustainable buildings for the longer term. However, it is shown that it is possible to achieve ambitious long term energy and GHG targets if phased

renovation is planned from the beginning with the aim to meet demanding targets in the longer term and in a way that the particular renovation steps are designed and carried out mutually coordinated. If renewable energy sources are deployed and the elements of the building envelope except the façade have a very high energy performance, it is even possible to achieve ambitious nonrenewable primary energy and GHG emission targets without insulating the façade. Moreover, good planning from the beginning allows benefitting from particular advantages of stepwise renovation without compromising existing energy and GHG targets for the longer term. It is shown that for the time being it is indispensable to foster the sustainability of stepwise building renovation. Among the supporting measures presented, fostering initial strategy development and concept elaboration for a longer term, comprising all of the upcoming renovation steps at the beginning of the renovation process is crucial. If building renovation is subsidized it should be required that subsidies are only given if such concepts for the longer term, comprising several renovation phases are elaborated first.

## 10 ACKNOWLEDGMENTS

The research project "Nachhaltige Gebäudeerneuerung in Etappen" ("Sustainable Stepwise Building Renovation") was commissioned by the research program "Energy in Buildings" of the SFOE. It was supported and co-financed by the cantons Basel-Stadt, Thurgau, Schaffhausen and the city of Zürich. We would like to thank these institutions for making this research possible and for supporting the work.

## 11 REFERENCES

Reports:

1. Lehmann, M., Ott, W., Bade, S., Inderbitzi, L., Rutz, M., Nachhaltige Gebäudeerneuerung in Etappen – SANETAP, econcept/Meier + Steinauer for the Swiss Federal Office of Energy, October 2015, Zürich, Switzerland, <http://www.bfe.admin.ch/dokumentation/energieforschung/index.html?lang=de#suchergebnisse>
2. SIA, SIA-Effizienzpfad Energie, Merkblatt 2040, issued 2011, Zürich, Switzerland
3. Ott, W., Jakob, M., Baur, M., Kaufmann, Y., Ott, A., Mobilisierung der energetischen Erneuerungspotenziale im Wohnbaubestand, econcept/CEPE for the Swiss Federal Office of Energy, November 2005, Zürich, Switzerland
4. Jakob, M., Martius, G., Catenazzi, G., Berleth, H., Energetische Erneuerungsraten im Gebäudebereich, TEP Energy for the Swiss Federal Office of Energy, 2014, Zürich, Switzerland

5. Banfi, S., Ramseier, C., Filippini, M., Erneuerung von Einfamilienhäusern – eine mikroökonomische Analyse für ausgewählte Schweizer Kantone, CEPE for the Swiss Federal Office of Energy, March 2011, Zürich, Switzerland
6. Banfi, S., Farsi, M., Jakob, M., An Analysis of Investment Decisions for Energy Efficient Renovation of Multi-Family Buildings, CEPE for Swiss the Federal Office of Energy, April 2012, Zürich, Switzerland
7. Wiencke A., Meins E., Anreize und Hemmnisse für energetische Sanierungen, Center for Corporate Responsibility and Sustainability UZH for Energieforschung Stadt Zürich, Forschungsprojekt FP-2.2.2, 2012, Zürich, Switzerland
8. Bächinger C., Meins E., Burkhard H.-P., Wiencke A., Massnahmen und Modelle zur Finanzierung von energetischen Erneuerungen, for Energieforschung Stadt Zürich, Forschungsprojekt FP-2.2.7, 2014, Zürich, Switzerland
9. Schalcher H., Boesch H., Bertschy K., Sommer H., Matter D., Gerum J., Jakob M., Fokusstudie NFP54. Was kostet das Bauwerk Schweiz in Zukunft und wer bezahlt dafür? vdf Hochschulverlag AG, 2011, Zürich, Switzerland
10. Van Wezemaal J. E., Investieren in Bestand: Eine handlungstheoretische Analyse der Erhalts- und Entwicklungsstrategien von Wohnbau-Investoren in der Schweiz, Ostschweizerische Geographische Gesellschaft, Heft 8, 2005, 2005, St Gallen, Switzerland
11. Alberini A., Banfi S., Ramseier C., Energy Efficiency Investments in the Home: Swiss Homeowners and Expectations about Future Energy Prices, CEPE Working Paper No. 80, August 2011, 2011, Zürich, Switzerland
12. Ott W., Bade S., Ritter V., Erneuerungsziele, nachhaltige Bewirtschaftungs- und Erneuerungsstrategien, econcept AG for Energieforschung Stadt Zürich, Forschungsprojekt FP-2.2.3, 2013, Zürich, Switzerland
13. Rütter H., Rütter U., Hässig W., Jakob M., Praxistest Minergie-Modernisierung. Rütter + Partner und hässig sustech for the Swiss Federal Office of Energy, November 2008, Bern, Switzerland



## Expanding Boundaries: Systems Thinking for the Built Environment

### ENVIRONMENT AND ECONOMY – AN ALLIANCE OF MUTUAL BENEFITS IN RESIDENTIAL BUILDING

V. John<sup>1\*</sup>, S.D.T. Schwarz<sup>1</sup>, G. Habert<sup>1</sup>

<sup>1</sup> ETH Zurich, Chair of Sustainable Construction,  
Stefano-Franscini-Platz 5, 8093 Zurich, Switzerland

\*Corresponding author; e-mail: viola.john@ibi.baug.ethz.ch

#### Abstract

Different environmentally and economically driven stakeholder interests in the building context are often seen as concurring concepts that are mutually exclusive. Owing to the fact, that the methods of Life Cycle Assessment (LCA) and Life Cycle Costing (LCC) are getting increasingly important in the predesign evaluation of a building's lifetime performance, it is about time to determine positive effects in the combination of both aspects. In order to clarify, which factors influence the environmental impact, as well as the life cycle costs of a building throughout its lifetime, the authors compare the LCA and LCC results of twelve recently constructed Swiss residential buildings, and identify the most significant building elements (e.g. roofs, ceilings, walls etc.) and life stages (construction, replacement, operation and deconstruction). The investigation shows for both the life cycle costs and the environmental impact of a building, that the most important building elements in this sample are ceilings, windows and external walls. The most important life stage, from a cost aspect, is the initial construction. As all buildings from the sample follow the state-of-the-art energy regulations in Switzerland, they induce comparably low costs during their operational stage. Nevertheless, for some of the inspected buildings the environmental impact results show a relatively high significance for the operational stage. The examination of this building sample suggests that in a residential building the alliance of environmental and economic interests provides mutual benefits for both.

#### Keywords:

Life Cycle Assessment LCA; Life Cycle Costing LCC; apartment buildings

#### 1 INTRODUCTION

In the past, the building industry has concentrated mainly on minimizing the initial construction cost, without taking further expenses or outcomes of design choices on the ecological effect of a building during its lifecycle into account. In result, the lion's share of structures in existing building stocks today are vigorously wasteful to operate and cause environmental impacts related to resource depletion and fossil fuel consumption.

As of late, more thorough building regulations and an adjustment in client requests have

become effective. Attributable to discourses about climate change and the way that the building sector represents around 40% of all primary energy usage for building operation [1], life cycle thinking and improving buildings from an ecological and in addition an economic point of view, have turned into an important issue during the planning process. Therefore, in recent years, scientists have proposed complementing Life Cycle Assessment (LCA) and Life Cycle Costing (LCC) approaches for a more sustainable evaluation of buildings during their lifecycle [2].

## Building characteristics

Building	01	02	03	04	05	06	07	08	09	10	11	12
Number of accommodation units	111	2	3	4	132	3	89	6	4	10	22	10
Type of construction	massive	hybrid	light-weight	massive	hybrid	light-weight	massive	hybrid	hybrid	massive	massive	hybrid
Energy reference area $A_E$ [m <sup>2</sup> ]	12.430	350,40	374	622,20	20.400	408	13.441	1.121,90	510,10	1.120	2.966	1.170

Fig. 1: Main characteristics of the buildings.

LCA and LCC approaches are especially gaining importance in the predesign assessment of a building's lifetime performance. The thought of a combined LCA and LCC approach is not new, but recent [3]. As different environmentally and economically driven stakeholder interests in the building context are often seen as concurring concepts that are mutually exclusive, it is about time to determine positive effects in the combination of these two counterparts. For this purpose, it is crucial to understand which factors mainly influence the environmental impact as well as the life cycle costs of a building throughout its lifetime.

Therefore, in this paper, the authors compare the LCC results with the LCA results of twelve recently constructed Swiss residential buildings and examine mutual similarities with regard to the most significant building components and life stages of the buildings.

## 2 DATA AND METHODS

The methodological approach for the LCA in this study is based on the international standard ISO 14040 [4] and 14044 [5], while the LCC approach follows the international standard ISO 15686-5 [6] and its adaptation for Switzerland "Leitfaden LCC – Planung der Lebenszykluskosten" [7]. The LCA results and all building characteristics as well as the LCA modelling specifications have been published in [8] and [9]. These building characteristics were then used for determining the life cycle cost. An overview of the twelve buildings and their most important attributes is shown in Figure 1. For the display of LCA results, the impact indicator GWP 100a for CO<sub>2eq</sub> emissions has been utilized (IPCC 2007 GWP 100a V1.02 [10], referring to a time horizon of 100 years for emissions).

The LCC approach required characterizing the general layout and system boundary of this study in accordance with the LCA model, by means of setting up the expenses for the different life stages (initial construction, maintenance, end-of-life and operation).

The LCC results were calculated by splitting the building into building components (floors, ceilings, external walls, internal walls, columns,

roofs, exterior doors, windows). Each of these components contained data about the materials and amounts utilized. Likewise, preliminary works (excavation and backfill) and building installations (heating and ventilation system) were considered. The operational stage of the buildings was tended to by including the annual energy demands for heating, domestic hot water, ventilation energy and household electricity. In order to be able to compare the LCA and LCC results, it was a prerequisite to define a common functional unit, to which the results of the environmental impact assessment as well as the cost assessment allude. In compliance with [8], this functional unit has been determined to be 1m<sup>2</sup> of energy reference area AE (referring to the heated floor space) per 1 year in the total lifetime of the building of 60 years (1m<sup>2</sup>/a).

The modelling of the LCC has been conducted in a seven-step approach, which is illustrated in Figure 2. The currency utilized for the calculation of the life cycle costs of the twelve buildings is Swiss francs (CHF). As all twelve buildings have been built within a similar time frame, it has been assumed for the following calculations that all the buildings have been constructed in year 0, go into operation in year 1 and are being demolished and disposed of in year 61. The base date for discounting future costs is set at the start of the operation at the beginning of year number 1.

The first step during the LCC calculation was to model each building element using cost reference values from the Swiss EAK catalogue [11] or BTK catalogue [12]. Cost reference values were accumulated per square metre for the initial construction as well as for the replacement and the disposal of each particular building element. The individual unit costs established during step 1 were then multiplied by the surface areas of each particular element for computing the total cost per element in step 2. This was done separately for the initial construction, replacement and demolition of each building element. Subsequently, the total costs for the replacement and the demolition established in step 2 were multiplied by their individual discount factor in order to estimate the present value in

## Modelling specifications LCC

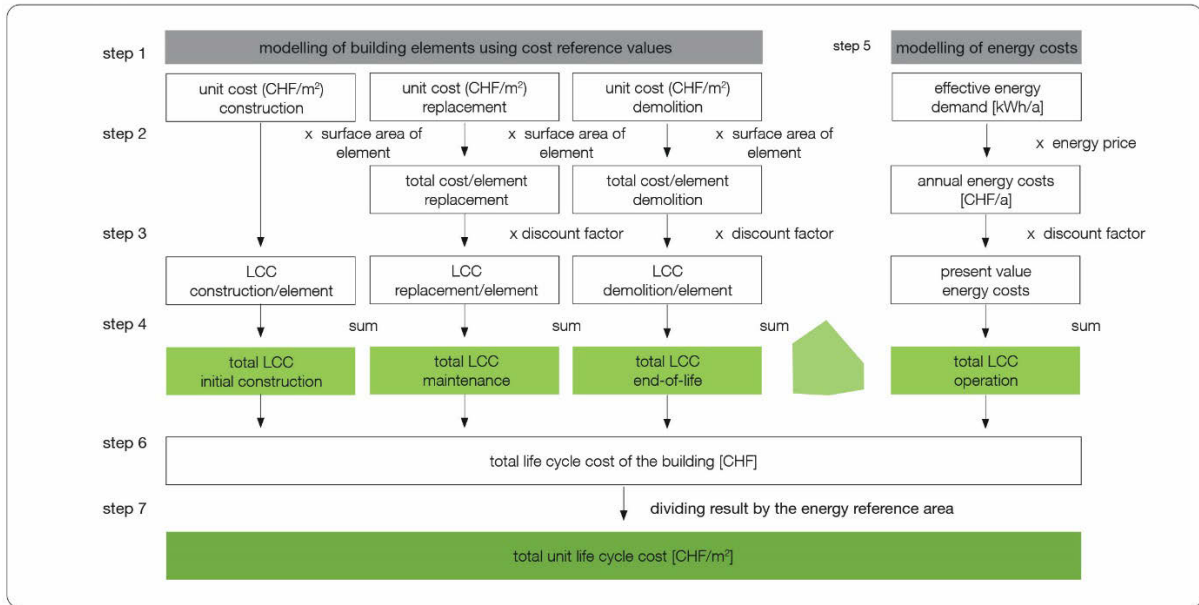

Fig. 2: Modelling specifications for the LCC approach.

step 3. The individual discount factor depends on the time at which a payment occurs. The initial construction costs do not need to be discounted as it has been assumed that they occur on the defined base date. In step 4, the initial construction cost and the present value of replacement and disposal costs for all the different building elements were added up to the total life cycle cost of the initial construction, maintenance and end-of-life separately. In step 5, the evaluation of the energy costs for the operation phase of the buildings was done as follows: The effective energy demand was used for the calculations and in those cases, where a building has a heat pump, the total energy demand was converted into the effective energy demand and divided by the assumed COP-Value of the heat pump (=3,5). Afterwards, the effective energy demand was multiplied by the energy unit price (CHF/kWh), resulting in the annual energy cost. The annual energy cost was then multiplied by its individual discount rate (depending on the year of its occurrence), which resulted in the present day value of the energy cost for a particular year. Finally, the life cycle cost for operation was computed by adding all the present values of the energy costs together. Afterwards, the total life cycle cost of each building was calculated in step 6 by adding the initial construction, maintenance, end-of-life and operation costs together. The final step was to divide the total life cycle cost from step 6 by the energy reference area, resulting in the total unit life cycle cost in CHF/m<sup>2</sup>.

### 3 RESULTS

A comparison of embodied CO<sub>2eq.</sub> emissions and life cycle costs, as depicted in Figure 3 demonstrates a similar tendency for the LCA and LCC results of the twelve buildings. Regardless of their type of construction, the most relevant life phase for most of the buildings is the construction stage, while the least important phase is the deconstruction / end-of-life stage. However, the buildings 7 and 10 have their most relevant impact on embodied CO<sub>2eq.</sub> emissions in the operation stage.

As all buildings from the sample follow the state-of-the-art energy regulations in Switzerland, they induce comparably low costs during their operational stage. Nevertheless, for the buildings 7 and 10, the results for embodied CO<sub>2eq.</sub> emissions show a relatively high significance of the operational stage. This is mainly due to the comparably high environmental impact regarding CO<sub>2eq.</sub> emissions of the energy carrier, which is natural gas (building 7) and district heating with natural gas (building 10). Most of the other buildings contain a heat pump powered by the Swiss electricity mix (which mainly consists of renewable energy) and therefore have a significantly lower impact with regards to CO<sub>2eq.</sub> emissions during their operation phase.

For this sample, the embodied CO<sub>2eq.</sub> emissions of the end-of-life stage contribute 4-14% to the overall LCA results, while the end-of-life stage has nearly 0% impact on the overall LCC results of all the buildings.

LCA and LCC results for each life stage of the buildings 1 to 6

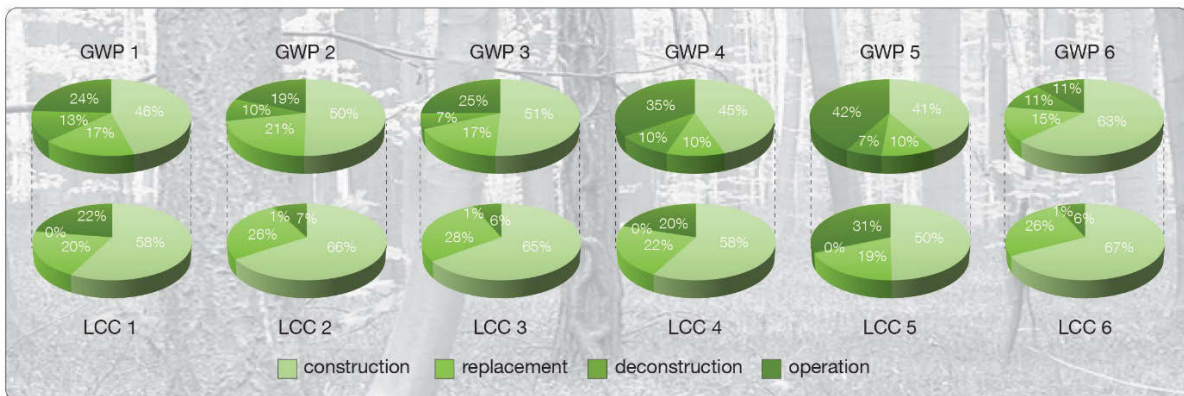

LCA and LCC results for each life stage of the buildings 7 to 12

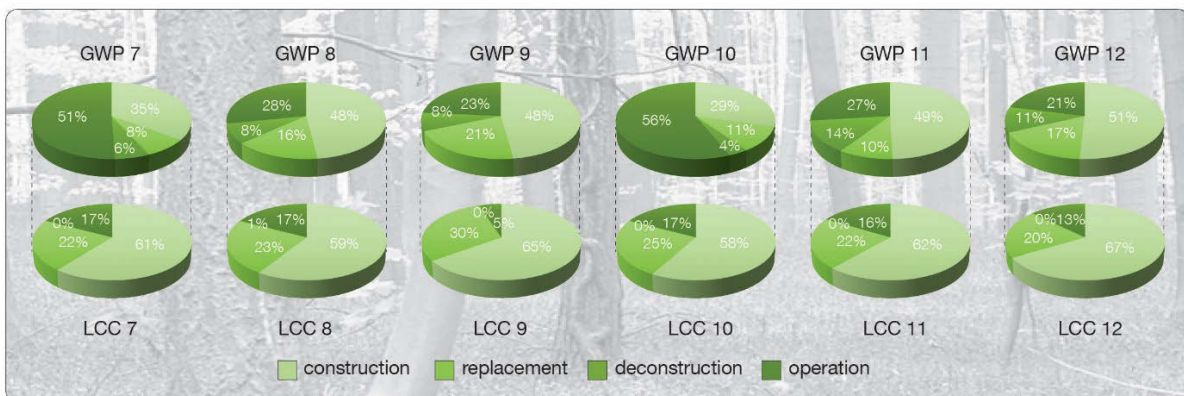

Fig. 3: Comparison of the shares of LCA and LCC results for each life stage of the twelve buildings.

When comparing embodied CO<sub>2eq.</sub> emissions and initial construction costs, the most relevant building components, regardless of the type of construction but regarding both LCA and LCC results of the 12 buildings, are ceilings, external walls and windows, as Figure 4 indicates. Additionally, for the buildings 1, 4 and 6, the roofs have a significant impact on the overall results, while the inner walls contribute significantly to the results of the buildings 9 and 12.

#### 4 DISCUSSION

It was stated in the introduction that in order to show mutual benefits in a combined use of the LCA and LCC approach, it is important to understand, which factors mainly influence the environmental impact, as well as the costs of a building throughout its lifetime. The results section has shown significant similarities in the LCA and LCC results of the twelve analysed residential buildings, both on the overall building level with its life stages and on the building element level. Furthermore, these similarities were observed in all the various types of construction (light-weight, hybrid and massive constructions). This means that there appears to

be a strong link between environmental and economic choices in building design in general.

This finding contradicts the assumption that different environmentally and economically driven stakeholder interests in the building context are concurring concepts. Consequently, in order to fully establish trade-off effects and mutual benefits of ecological and economic decisions, it seems inevitable to investigate both LCA and LCC aspects in a holistic approach. As in this example only residential buildings and solely one environmental impact indicator (GWP 100a) were utilized for the assessment, further research should investigate, if similar results are derived from other types of buildings (e.g. office buildings) as well as alternative indicators (e.g. non-renewable primary energy).

#### 5 CONCLUSIONS

The examination of this building sample suggests, that in residential building the alliance of environmental and economic interests provides mutual benefits for both. The joined use of LCA and LCC empowers the estimation of the environmental impact and cost of a building at different phases of its lifetime, looking at alternative options and recognizing the ecologically and also economically most sensible long-term solution.



LCC and LCA results of the building elements (comparison of initial construction cost & embodied CO<sub>2</sub>eq. emissions GWP 100a)

Fig. 4: Comparison of the shares of LCC and LCA results for each building element.

## 6 ACKNOWLEDGMENTS

The authors would like to express their thanks to Eric Delé, Ian-Frédéric Haefliger, Roberto Mettler, Alexander Minor and Céline Staub for their enthusiasm and valuable contribution to the data collection for the life cycle cost calculations of the building sample, as part of their individual semester project works at the Chair of Sustainable Construction at ETH Zurich.

## 7 REFERENCES

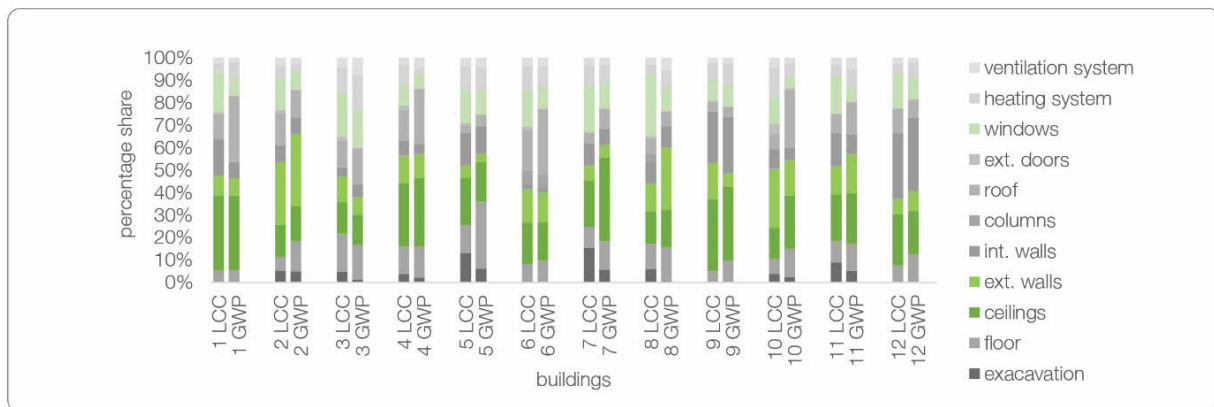
- United Nations Environment Programme, Building and Climate Change: Status, Challenges and Opportunities. 2007, United Nations Environment Programme: Paris, France.
- Gluch, P. and H. Baumann, The life cycle costing (LCC) approach: a conceptual discussion of its usefulness for environmental decision-making. *Building and Environment*, 2004. 39(5): p. 571-580.
- Heijungs, R., E. Settanni, and J. Guinee, Toward a computational structure for life cycle sustainability analysis: unifying LCA and LCC. *International Journal of Life Cycle Assessment*, 2013. 18(9): p. 1722-1733.
- ISO International Organization for Standardization, ISO 14040. Environmental management - Life cycle assessment - Principles and framework. 2006.
- ISO International Organization for Standardization, ISO 14044. Environmental management - Life cycle assessment - Requirements and guidelines. 2006.
- ISO International Organization for Standardization, ISO 15686-5:2008 Standardized method of life cycle costing for construction procurement a supplement to buildings and constructed assets - service life planning - Part 5: Life cycle costing. 2008.
- CRB Schweizerische Zentralstelle für Baurationalisierung, Leitfaden LCC Planung der Lebenszykluskosten Schweizerische Umsetzung der ISO 15 686-5. Standards für das Bauwesen. 2012, Zurich: CRB.
- John, V., Derivation of reliable simplification strategies for the comparative LCA of individual and "typical" newly built Swiss apartment buildings. 2012, ETH Zurich.
- Wyss, F., Frischknecht, R., Pfäffli, K. and John, V., Zielwert Gesamtumweltbelastung Gebäude. Machbarkeitsstudie. Bundesamt für Energie BfE, Bundesamt für Umwelt BAFU, Amt für Hochbauten der Stadt Zurich AHB, 2014.
- IPCC Climate Change 2007: Working Group I: The Physical Science Basis. 2007.
- CRB Schweizerische Zentralstelle für Baurationalisierung, EAK – Kostenkennwerte – Elementarten Katalog. 2011: Zurich.
- Holliger Consult. Elektronischer Bauteilkatalog. Available from: <http://www.bauteilkatalog.ch/>.





## Expanding Boundaries: Systems Thinking for the Built Environment

### A FRAMEWORK FOR LIFE CYCLE ASSESSMENT OF CONCRETES WITH RECYCLED AGGREGATES IN LARGE METROPOLITAN AREAS

A. Yazdanbakhsh<sup>1\*</sup>, L.C. Bank<sup>1</sup>, T. Baez<sup>1</sup>, I. Wernick<sup>2</sup>, A. Hamidi<sup>1</sup>

<sup>1</sup> City College of New York, Civil Engineering Department, 160 Convent Avenue, New York, NY 10031, USA

<sup>2</sup> City College of New York, CCNY Sustainability Program, 160 Convent Avenue, New York, NY 10031, USA

\*Corresponding author; e-mail: ayazdanbakhsh@ccny.cuny.edu

#### Abstract

The use of coarse recycled aggregates (RCAs) obtained from crushing and grading of concrete construction and demolition waste (CDW) has been widely studied and commercialized in several countries. In the US, over 350 million tons of CDW is produced yearly; 140 million tons of which is concrete that is recycled and used primarily as road-base, fill and drainage material. Only a small portion of U.S. RCA is used in structural concrete, and then only in pavements. To make a compelling case for the use of these recycled materials in concrete, in addition to mechanical performance and durability of RCA concrete, the environmental impacts of replacing coarse natural aggregates (NAs) with RCA need to be investigated. These impacts are highly dependent on local conditions, local recycled material sources, aggregate production methods, transportation distances, and concrete mix proportions. The presented study focuses on the local conditions of New York City metropolitan area and utilizes Life Cycle Assessment (LCA) to compare the environmental impacts of using either natural or recycled aggregates in structural concrete.

#### Keywords:

Aggregate; concrete; LCA; RCA; recycled

## 1 INTRODUCTION

For decades the concrete portion of construction and demolition waste (CDW) has been processed into coarse aggregates, referred to as recycled concrete aggregate (RCA) (Fig. 1). RCA is usually used as a replacement for coarse natural aggregate (NA) (Fig. 2), i.e., crushed stone or gravel, for unbonded applications such as drainage filler and base material in road construction. RCA can be used in concrete as a replacement for NA. The construction codes in many countries, e.g., Germany, Switzerland and Spain allow the partial replacement of NA with RCA in structural concrete [1]. The main constituents of concrete are water, portland cement, coarse aggregate (typically crushed stone), and fine aggregate (sand). To determine if any of these constituents can be replaced with a new material, parametric studies are performed to compare the mechanical properties, durability,

and cost of concrete with the conventional and new materials. Today, sustainable development and the impact of materials, during their life cycle, on the environment is of paramount importance. Landfilling regulations are becoming more stringent and green building certification programs such as LEED [2] are being widely used. Therefore, it is important to compare the environmental impacts of using alternative constituents in concrete. Some of the environmental benefits of using RCA as a replacement for NA are obvious. For example, production of NA requires the consumption of natural resources through mining, typically by using explosives. In some countries (e.g., Qatar) there is a shortage of rocks and NA is mostly imported. Moreover, recycling CDW leads to a reduction in the size of landfills. The above-mentioned benefits can be achieved regardless of the application for which RCA is used. The quality and cost of concrete aggregate is higher

than the aggregate used in unbonded applications. It is therefore important to compare the environmental impacts of producing concrete with NA and RCA. For this purpose, life cycle assessment (LCA) must be performed, with a focus on the parameters that differ between NA and RCA concretes throughout their lifecycles. Few such comparative LCA studies have been performed in the past [3, 4]. The environmental impacts of concrete production depend on regional factors such as transportation distances and means, and the methods used for the production of the raw materials. This work presents a preliminary LCA study which compares the environmental impacts of producing NA and RCA concrete in the New York City area.



Fig. 1: Recycled concrete aggregate (RCA) graded as coarse aggregate.



Fig. 2: Crushed granite used as coarse natural aggregate (NA) in concrete.

## 2 METHODOLOGY

### 2.1 Goal and scope

The goal of this study is to determine the difference in the environmental impacts of producing the same volume of NA and RCA concretes with the same compressive strength in the New York City area. The total amount of concrete that can be made monthly using the RCA produced by the recycling plants in the New York City area with their full production capacity

was used as the unit volume. In this study the New York City area is defined as an area of land within a circle centered at Manhattan, NY with a radius equal to the length of Long Island (Fig. 3). The area has a high density of RCA and NA production plants that supply New York City.

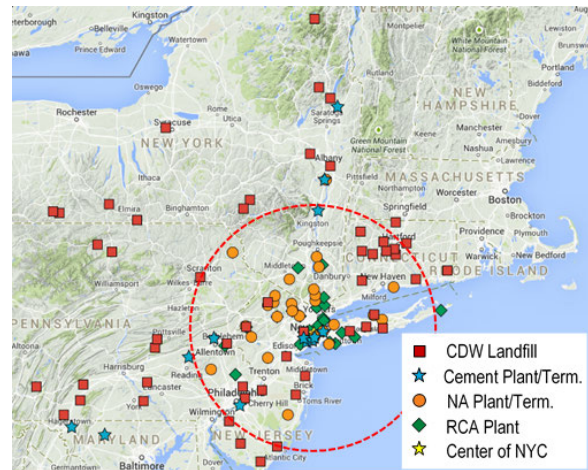

Fig. 3: The region investigated in the study.

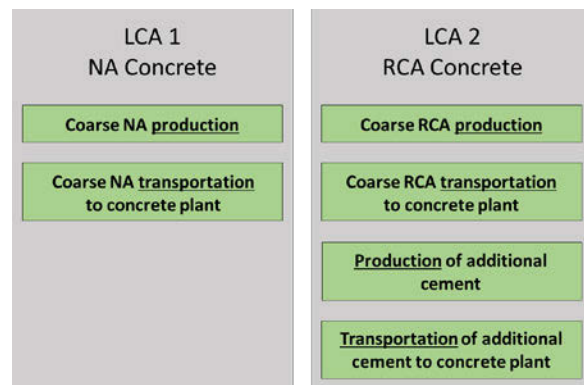

Fig. 4: The LCAs performed on the life cycle phases of NA and RCA concretes that are unique.

In this study only the environmental impacts of the stages of lifecycle that differ between NA and RCA concretes were measured and compared. Those stages are (1) coarse aggregate production, (2) transportation of coarse aggregates to the concrete production plant, and (3) production and transportation of additional cement. When NA is fully replaced with the same volume of RCA in a concrete mix the compressive strength of concrete can decrease by as much as 30% [5].

### 2.2 Assumptions

The following assumptions were made in this study:

- (i) 30% of the CDW processed in an RCA plant is suitable for use as coarse aggregate in concrete. The remaining 70% is sold as unbonded aggregates and fillers. This assumption was made based on the findings

from interviewing a number of RCA plants in the New York City area.

- (ii) All the concrete consumed in New York City is produced at the centre of the city (Empire State Building), to which the aggregate and cement must be transported.
- (iii) The only difference in the mix properties of NA and RCA concretes having the same compressive strength that influences the environmental impact is the additional cement in the RCA concrete.
- (iv) Producing NA and RCA concretes in a concrete production plant has the same environmental impact.
- (v) Both the NA and RCA concretes have the same durability, need for repair and maintenance, and the same period of service life. Therefore, the “use” or “service” period of concrete life cycle was not incorporated in this LCA.

Fig. 5 shows the transportation routes associated with the production of coarse aggregates and delivering them to a concrete plant. NA production plants are typically located in rock quarries or gravel pits and the transportation within the plant is minimal; the transportation is mainly associated with sending the NA to the concrete production plant. As for RCA, first the CDW must be transported from the construction or demolition site to an RCA Plant (T1). By doing so, the transportation of CDW to a landfill (T3) is avoided. The produced RCA is then transported from the RCA plant to a concrete production plant (T2). It should be mentioned that since 30% of the processed CDW is usable for concrete, to transport each ton of RCA from the RCA plant to the concrete plant, 3.3 tons of CDW is transported from a construction or demolition site to the recycling plant.

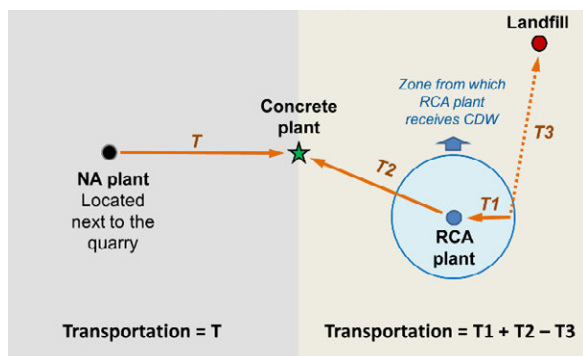

Fig. 5: Transportation required for producing and sourcing coarse aggregate.

## 2.3 Database and data collection

### 2.3.1 Transportation distances

The location of the main producers of NA and RCA and their distribution terminals in the New York City area were found. In addition, the main regional producers of cement that supply New York City were located. Also the CDW landfills

that receive waste from New York were located. Some of the above-mentioned cement producers and landfills are not located in the New York City area. Some of them are in other states including New Jersey, Pennsylvania, and Connecticut. 28 NA production plants and terminals, 37 RCA plants, 14 cement producers/terminals, and 85 CDW landfills were identified. It was found that NA from many of the quarries is partially transported by barges (mostly on Hudson River). In the majority of the cases, the NA is shipped by barge to main distribution terminals in or close to New York City and then transported by truck to other distributors or directly to concrete production plants. The water and land transportation distances were distinguished as the two types of transportation cause different environmental impacts. To find a value for the transportation distance  $T$  (Fig. 5), and its water and land portions, the water and land transportation distances of all the NA plants to the centre of New York City were averaged. The distances for transporting cement and RCA to the centre of New York were calculated similarly. It was assumed that CDW, if landfilled, is sent to either of the two closest landfills to the RCA plant which is closest to the CDW source. Therefore, for each RCA plant, to calculate the distance for the alternative transportation of CDW to a landfill, the distance between each RCA plant and the two closest CDW landfills were averaged.  $T3$  (Fig. 5) was calculated by averaging all the above-mentioned alternative transportation distances. Managers of several RCA plants were interviewed to find the average distance between demolition sites and an RCA plant ( $T1$ ). The distance of 48 kilometres (30 miles) was used for  $T1$ . Google Maps was used to identify the truck and water routes and find transportation distances.

### 2.3.2 Life cycle inventories

In this study, the LCA for NA concrete production incorporates three “processes”: (i) NA production, (ii) transportation (of NA) by water, and (iii) transportation by truck. The LCA for RCA concrete production incorporates four processes: (i) RCA production, (ii) cement production (iii) transportation (of CDW, RCA, and cement) by truck, and (iv) transportation (of cement) by water.

A life cycle inventory (LCI) is a list of inputs and outputs, and their amounts for each process. The inputs consist of energy, raw materials and ancillary inputs. The outputs are the products, co-products, solid waste, emission to air, and discharge to water and soil. The amounts of the outputs from all the processes in an LCA is used by life cycle impact assessment (LCIA) methodologies to calculate values for different environmental impacts such as global warming potential (GWP).

For transportation and cement production commercially available LCIs were used. Since a commercial LCI for RCA production was not available, data from the literature was used to compile LCIs for both RCA and NA production [6]. It should be mentioned that the data is collected from European aggregate production plants and, therefore, cannot accurately represent the emissions caused by aggregate production in the New York City area. For example, the machinery in some European plants use biofuel, which results in the emission of different gasses and particles, compared to the emissions from heavy fuels used in New York.

### 2.3.3. Concrete mix proportions

Many studies have been performed on proportioning NA and RCA concrete mixes to achieve the same compressive strength. There is a significant variation in findings on the additional amount of cement required for concrete with the full replacement of NA with RCA. For example for the type of RCA and mix design used by Knaack and Kurama [7] no additional cement was required. In the experimental study performed by Bai and Sun [8] the additional amount of cement required was 9% of the weight of RCA. In this study the mix proportions presented by Etxeberria et al. in which the amount of additional cement was 2% of the weight of RCA is used [9]; this additional amount of cement is also consistent with the findings from the preliminary investigations of the authors for the RCA in the New York City area.

### 2.3.4 Life cycle impact assessment

There are numerous methodologies for measuring different environmental impacts in an LCA. Each methodology defines a number of impact categories such as "Global warming" and "Eutrophication". In an LCA the magnitude of each impact category is calculated by multiplying the magnitudes of outputs from the LCIs of the processes in the LCA by the categorization (or weighing) factors defined by the methodology used for impact assessment. There are two types of impact categories; midpoint and endpoint (Fig. 6). Midpoint impacts can be quantified with a relatively high accuracy and have environmental themes such as climate change, acidification and human toxicity. Endpoint environmental impacts are more detailed and directly related to human health, natural environment, and natural resources. In this study the ReCiPe methodology [10] was used to measure three midpoint impacts often used by decision and policy makers: (1) climate change potential, (2) acidification, and (3) human toxicity. GaBi platform [11] was used for performing the LCAs.

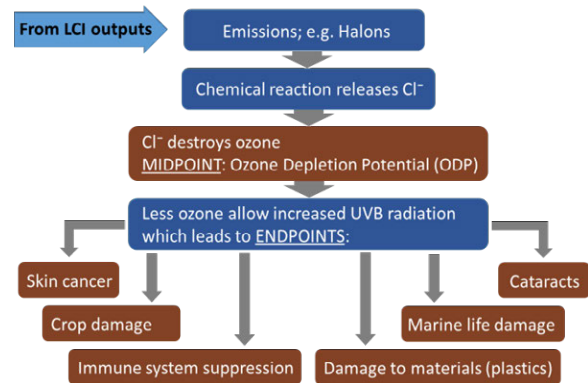

Fig. 6: Midpoint vs. endpoint impact categories. (From GaBi literature).

## 3 RESULTS

The results for the investigated midpoint environmental impacts from LCA of NA and RCA concretes are presented in Figures 7 to 9. Fig. 7 shows the results for the climate change potential, which is notably higher for NA concrete due to the higher emissions caused by transportation (by truck and water). One reason is that NA production plants, compared to RCA plants, are further from the centre of the New York City area. The other reason is the transportation of CDW to the landfills (T3, Fig. 5) is avoided when the waste is transported to the nearby RCA production plants. Fig. 10 shows that the avoided transportation of CDW to the landfills reduces the total environmental impacts caused by transportations T1 and T2 by 80%.

Fig. 7 shows that the additional cement used in RCA concrete has a clear impact on climate change. Therefore, if for another type of RCA or different mix design, such as those used by Bai and Sun [8], more additional cement is required for RCA concrete, the climate change potential caused by this type of concrete will be higher than that from producing NA concrete.

Fig. 8 presents the acidification impact results. Acidification is highly affected by water transportation and since in the New York City area RCA is transported only by truck the acidification impact of producing RCA concrete is significantly smaller than that of NA concrete. Fig. 9 shows the human toxicity results. Human toxicity is mostly affected by cement production and therefore the overall human toxicity caused by RCA concrete production is higher due to the additional cement used in this type of concrete.

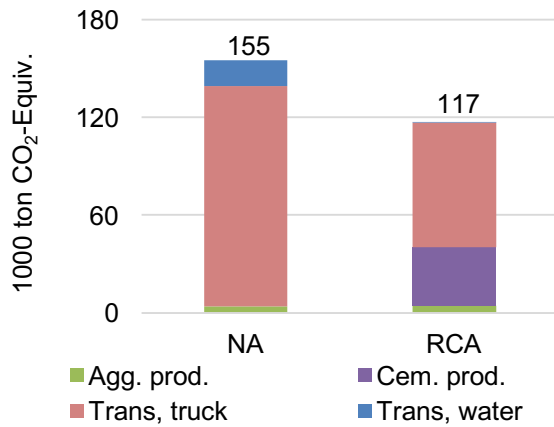

Fig. 7: Climate change potential from the LCAs of NA and RCA concretes.

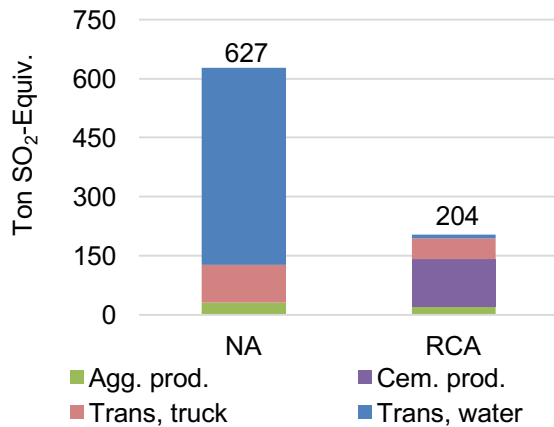

Fig. 8: Acidification impact results from the LCAs of NA and RCA concretes.

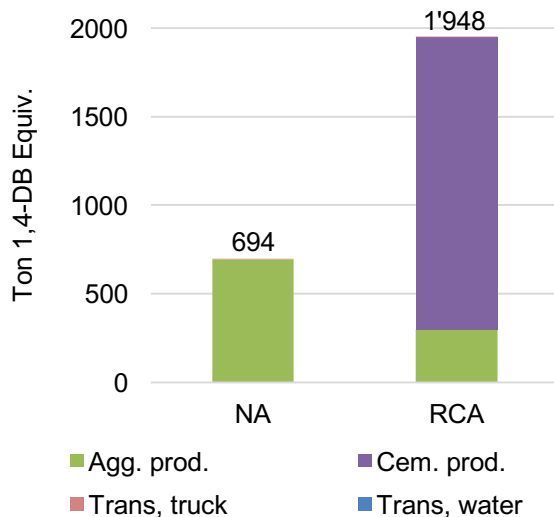

Fig. 9: Human toxicity impact results from the LCAs of NA and RCA concretes.

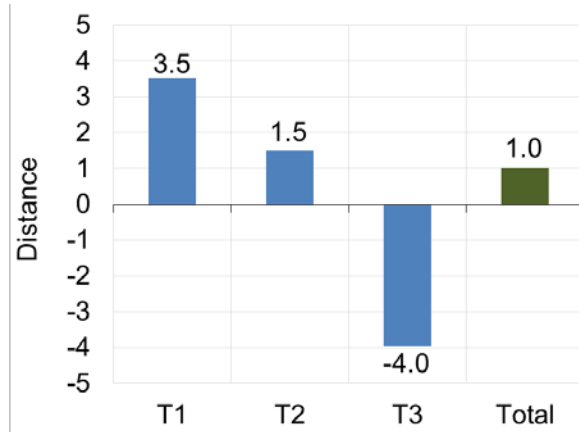

Fig. 10: Contribution of different stages of transportation for RCA concrete on environmental impacts.

#### 4 SUMMARY AND CONCLUDING REMARKS

A life cycle assessment was performed to compare some of the main midpoint environmental impacts caused by producing the same volume of NA and RCA concretes with the same compressive strength in the New York City area. The LCAs consisted of only those phases of life cycles of NA and RCA concrete production that were different. Those phases are coarse aggregate production, transportation, and cement production. The results showed that transportation and cement production affected the studied environmental impacts significantly. Transportation by truck has the highest impact on climate change potential. The overall total transportation by truck for RCA concrete production is lower than that for NA concrete production due to the significant amount of transportation avoided by not sending the CDW to landfills. It was also found that the small additional cement used for RCA concrete production has a significant impact on human toxicity.

More detailed comparative LCAs with less simplifying assumptions should be performed for the production of RCA concrete in the New York City area. The location of concrete production plants in the area should be identified to calculate a more realistic total distance for the transportation of NA and RCA to the plants. In addition, since increasing the cement content in a mix changes the ratios of other constituents of concrete, performing an LCA that incorporates the processes of the production of all the constituents of concrete will lead to more accurate results.

## 5 ACKNOWLEDGMENTS

This study was sponsored by the U.S. National Science Foundation through Grant No. 1345379. The authors wish to thank Marc Bretz from Con-Strux Company for supporting this research project and supplying the recycled concrete aggregate.

## 6 REFERENCES

1. J. De Brito, N. Saikia, Recycled aggregate in concrete, use of industrial, construction, and demolition waste, Springer 2013.
2. U.S. Green Building Council. <http://www.usgbc.org/leed>. 2015).
3. S. Marinkovic, V. Radonjanin, M. Maleev, I. Ignjatovic, Comparative environmental assessment of natural and recycled aggregate concrete, *Waste Manag.* 30(11) (2010) 2255-2264.
4. C. Knoeri, E. Sanyé-Mengual, H.-J. Althaus, Comparative LCA of recycled and conventional concrete for structural applications, *Int J Life Cycle Assess* 18(5) (2013) 909-918.
5. A. Yazdanbakhsh, L.C. Bank, J. Rosen, Flexural strength of reinforced concrete beams incorporating coarse recycled concrete aggregate, ACI Special Publication, Technical Committee 555. (2016).
6. A. Korre, S. Durucan, Life cycle assessment of aggregates, EVA025 -Final Report: Aggregates Industry Life Cycle Assessment Model: Modelling Tools and Case Studies (2009).
7. A. Knaack, Y. Kurama, Behavior of reinforced concrete beams with recycled concrete coarse aggregates, *J. Struct. Eng.* DOI: 10.1061/(ASCE)ST.1943-541X.0001118. (2014).
8. W. Bai, B. Sun, Experimental study on flexural behavior of recycled coarse aggregate concrete beam, *Applied Mechanics and Materials* 543 (2010) 29-32.
9. M. Etxeberria, A.R. Marí, E. Vázquez, Recycled aggregate concrete as structural material, *Mater. Struct.* 40(5) (2007) 529-541.
10. M.J. Goedkoop, R. Heijungs, M. Huijbregts, A. De Schryver, J. Struijs, R. Van Zelm, ReCiPe 2008, A life cycle impact assessment method which comprises harmonised category indicators at the midpoint and the endpoint level, Report I: Characterisation, First edition <http://www.lcia-recipe.net> (2009).
11. GaBi Software for Life Cycle Assessment. <http://www.gabi-software.com/america/>. 2015).





## Expanding Boundaries: Systems Thinking for the Built Environment

### LIFE CYCLE ANALYSIS OF RECYCLED AGGREGATE CONCRETE WITH FLY ASH AS PARTIAL CEMENT REPLACEMENT

S. Marinković<sup>1\*</sup>, G. Habert<sup>2</sup>, I. Ignjatović<sup>1</sup>, J. Dragaš<sup>1</sup>, N. Tošić<sup>1</sup>, C. Brumaud<sup>2</sup>

<sup>1</sup> Faculty of Civil Engineering, University of Belgrade, Bulevar kralja Aleksandra 73, Belgrade, Serbia

<sup>2</sup> ETH Zürich, Stefano-Franscini Platz 5, Zürich, Switzerland

\*Corresponding author; e-mail: [sneska@imk.grf.bg.ac.rs](mailto:sneska@imk.grf.bg.ac.rs)

#### Abstract

This paper presents a part of the results obtained within the frame of the SCOPES joint research project – a scientific collaboration between ETH Zürich and Faculty of Civil Engineering, University of Belgrade. One of the goals of the project was to produce recycled aggregate concrete with fly ash as partial cement replacement, which would have mechanical and durability-related properties adequate for structural concrete. At the same time the aim was to replace as much as possible natural resources with waste materials to achieve environmental and cost efficiency. Three mixtures of recycled aggregate concrete were designed with percentages of cement replacement with fly ash equal to 0%, 19% and 38%. Equal compressive strength was set as the design goal and environmental impact assessment was based on that fact. The results of these tests showed that it was possible to reach the same 28-day compressive strength for all three concretes with established mix design procedures. The environmental impacts of the tested concretes types were assessed using the standardized methodology of Life cycle assessment (LCA). The assessment was based mostly on local LCI data and on typical conditions in Serbia. Regarding the impact of fly ash, three different allocation procedures were tested: 'no-allocation', 'mass allocation' and 'economic allocation'. Comparative environmental assessment showed that environmental benefits from replacing a part of the cement with fly ash could be gained in the 'no-allocation' and the 'economic allocation' case. In the case of 'mass allocation', all calculated environmental impacts were higher for recycled aggregate concrete with fly ash.

#### Keywords:

Recycled aggregate concrete; fly ash; LCA; environmental impact; allocation

## 1 INTRODUCTION

Having in mind environmental, cost and social effects, the concrete industry is regarded as the most significant one within the construction and building materials industry. Considering the volume of produced concrete and number of built concrete structures (roughly 25 billion tons of concrete are produced globally each year, or over 3.8 tons per person per year [1]), the problem of the concrete environmental impact forms a significant part of the global problem of sustainable development. The specific amount of harmful impacts embodied in a concrete unit is, in comparison with other building materials,

relatively small. However, due to the high global production of concrete, the final negative environmental impact of concrete structures is significant: a large consumption of natural resources (aggregates for cement and concrete and energy), large CO<sub>2</sub> emissions (due to cement production) and a large amount of produced construction and demolition (C&D) waste.

So far a lot of effort has been put into finding sustainable solutions for concrete as a structural material, since concrete is the most widely used in structures. Most of this research was directed towards the partial replacement of cement with

supplementary cementitious materials (fly ash, blast furnace slag, silica fume etc.) or towards the complete replacement of cement with alkali activated binders. The main aim was to reduce the CO<sub>2</sub> emissions since cement production is its major source. The other extensively investigated approach was to replace natural aggregates with recycled ones in order to decrease the natural resources consumption and amount of generated C&D waste.

Research done so far showed that it was possible to produce a concrete which can be used in some structural applications, with partial replacement of cement with fly ash (FA), depending on the amount of replacement [2, 3, 4]. The same goes for the concrete made with partial replacement of natural aggregate (NA) with recycled concrete aggregate (RCA) [5, 6, 7, 8]. The question is then raised if it is possible to produce a structural concrete by replacing both cement and aggregates with waste materials, FA and RCA. And how it would affect the environmental impact of concrete.

## 2 OBJECTIVES

The objective of the work presented here was to replace as much as possible natural resources in concrete with waste materials to achieve environmental efficiency. To obtain this goal the attempt was made to produce the concrete with partial replacement of cement with FA and partial replacement of NA with RCA, using local Serbian resources. Such concrete should have mechanical and technological properties complying to the requirements for structural concrete. Life cycle assessment (LCA) was performed to estimate the environmental impacts of those concretes.

## 3 METHOD

An experimental program was carried out to obtain the mix proportions of three different recycled aggregate concrete (RAC) types, so that all of them have the same compressive strength and workability:

RAC\_FA0 – recycled aggregate concrete with no fly ash

RAC\_FA19 - recycled aggregate concrete with 19% replacement of control RAC\_FA0 cement mass with fly ash

RAC\_FA38 - recycled aggregate concrete with 38% replacement of control RAC\_FA0 cement mass with fly ash

Recycled aggregate concrete was made with coarse RCA and fine NA (sand). In concretes where part of the cement was replaced with FA (RAC\_FA19 and RAC\_FA38), a part of the aggregates was also replaced with FA. Maximum aggregate content that could be replaced was determined on the basis of the required

aggregate mixture particle size distribution according to standard [9].

Selected environmental impacts of these three concrete types were calculated using LCA for the part of the concrete's life cycle which includes the production of aggregates, cement and FA production, production of ready-mixed concrete and transport.

### 3.1 Mix proportions and properties of concrete

Coarse recycled aggregate was obtained from a demolished reinforced concrete structure which has been exposed to weather conditions for more than thirty years. The crushing of the demolished concrete and screening into three particle sizes, 4/8 mm, 8/16 mm and 16/32 mm, was performed in a mobile recycling plant. Fine natural aggregate, size 0/4 mm, was river aggregate (Morava river). Properties of recycled and natural aggregates are shown in Table 1.

Aggregate type	Dry density (kg/m <sup>3</sup> )	Absorption (%)
0-4 mm NA	2573	1.2
4-8 mm RCA	2309	4.6
8-16 mm RCA	2370	3.7
16-32 mm RCA	2372	3.8

Table 1: Properties of NA and RCA.

Fly ash was obtained from the coal-fired power plant "Nikola Tesla B" (TENT) in Obrenovac, Serbia, while blended Portland cement CEM II/A-M (S-L) 42.5R was used. This type of cement has additions (grinded slag and limestone) up to 20% of the total mass. The chemical composition and physical properties of FA and cement are presented in Table 2.

Property	Cement CEM II 42.5R	Fly ash
SiO <sub>2</sub> (%)	21.04	58.24
Al <sub>2</sub> O <sub>3</sub> (%)	5.33	20.23
Fe <sub>2</sub> O <sub>3</sub> (%)	2.37	5.33
SiO <sub>2</sub> + Al <sub>2</sub> O <sub>3</sub> + Fe <sub>2</sub> O <sub>3</sub>	-	83.80
TiO <sub>2</sub> (%)	-	0.45
CaO (%)	60.43	7.62
MgO (%)	2.43	2.01
P <sub>2</sub> O <sub>5</sub> (%)	-	0.00
SO <sub>3</sub> (%)	3.55	2.21
Na <sub>2</sub> O (%)	0.22	0.52
K <sub>2</sub> O (%)	0.70	1.51
MnO (%)	-	0.03
LOI (%)	3.53	2.10
Fineness (>45 μm, %)	-	11.71
Specific gravity (kg/m <sup>3</sup> )	3040	2075

Table 2: Chemical and physical properties of cement and fly ash.

A series of laboratory tests were carried out to obtain the target compressive strength (35 MPa) and target workability (slump equal to 15 cm). The final mix proportions and properties are shown in Table 3. Compressive strength was tested on 100-mm cube samples and values reported in Table 3 are the mean values from three compressive strength test results.

Concrete mixtures with high content of FA were very dry and incoherent in their fresh state and it was necessary to add a certain amount of superplasticizer to obtain a workable mixture. It was noticed that small changes of the superplasticizer content resulted in a significant change in workability. For example, 1.54 kg/m<sup>3</sup> and 2.57 kg/m<sup>3</sup> of superplasticizer caused RAC\_FA19 and RAC\_FA38 mixtures to turn into flow, respectively. However, with a somewhat smaller amount of superplasticizer, a required slump of 15 cm can be obtained.

### 3.2 Environmental assessment

The environmental assessment was performed using LCA methodology, and particularly for the impact assessment, the Institute of Environmental Sciences (CML) baseline method [10] was used.

The goal of this study was to compare the environmental impact of the production of three types of ready-mixed RAC in Serbia: RAC\_FA0, RAC\_FA19 and RAC\_FA38. The analysis was limited to a 'cradle-to-gate' level (extraction and production of constituent materials, production of concrete and transport) and the system boundaries are shown in Figure 1. Since the superplasticizer mass was lower than 0.15% of the concrete mass, its impacts were neglected.

To enable the choice of functional unit only in mass units (in this case one cubic meter of concrete), it is necessary that all analysed different types of concrete fulfil the same functional requirements. This means that they must have the same strength (mechanical properties), workability and durability. For that reason, the mix proportions were determined so that all types of concrete have the same compressive strength and workability. Besides, it was assumed that the durability of analysed concretes was similar if they were exposed to non or low aggressive conditions.

Regarding the production of recycled concrete aggregate, the cut-off rule was applied, i.e. no impacts from parent natural aggregate concrete (NAC) production and all the impacts from recycling were allocated to the RCA production. Production of RCA included the recycling process itself (in a mobile recycling plant, typical for Serbia), transportation of the mobile recycling plant to the demolition site and landfilling of the recycling waste which cannot be used as RCA (assumed recovery rate equal to 60%). For each

campaign of 2500 t the mobile plant (20 t) is transported at a distance of 200 km.

Life cycle inventory (LCI) data for aggregate, cement and concrete production, as well as for FA treatment, were site-specific data, obtained from local Serbian suppliers whose products were used for the concrete mix [11,12]. Emission data for diesel production and transportation, natural gas distribution and transport that couldn't be collected for local conditions were taken from the Ecoinvent database [13, 14].

The environmental impact categories included in this work were: abiotic depletion, climate change (global warming as indicator), ozone layer depletion, eutrophication, acidification and photochemical oxidant creation (POC) – summer smog. Besides, the cumulated energy requirement was calculated and expressed as 'energy use'. They were calculated using an original excel-based software made for life cycle inventory and life cycle impacts calculation. As already mentioned, for category indicators calculation the CML methodology [10] was used. It should be pointed out that this methodology does not include solid waste production/landfill capacity as an impact category, or consider sand and stone as abiotic resources that can be depleted.

Transport distances were estimated for the construction site located in Belgrade, the capital of Serbia. For this case, the typical transportation distances and types are as shown in Table 4.

Regarding the RCA transport distance (100 km), it was assumed that the demolition site (which was a source of demolished concrete) is located at 100 km distance from Belgrade.

Since FA is no longer considered as merely waste but as a useful by-product [15], it carries a part of the environmental load of the electricity production in the coal-fired power plant (primary process – main product), besides the load from its own treatment prior to utilization in concrete (secondary process – by-product). Secondary process includes only the transport from electromagnetic separator to the storage silo which is a pneumatic process powered by electricity in the power plant TENT [12].

For the calculation of the part of the primary process environmental load which should be allocated to FA, three types of allocations were considered:

'No allocation' – FA was considered as waste; only impacts from secondary process were included

'Mass allocation' – impacts of primary process were allocated between the main product and by-product according to the ratio of their masses.

The mass allocation coefficient  $C_m$  can then be calculated as [16]:

$$C_m = \frac{m_{byproduct}}{m_{mainproduct} + m_{byproduct}} \quad (1)$$

where  $m_{byproduct}$  is FA mass and  $m_{mainproduct}$  is electricity mass.

'Economic allocation' – impacts of primary process were allocated between the main product and by-product according to the ratio of their prices.

The economic allocation coefficient  $C_e$  can then be calculated as [16]:

$$C_e = \frac{(\varepsilon \cdot m)_{byproduct}}{(\varepsilon \cdot m)_{mainproduct} + (\varepsilon \cdot m)_{byproduct}} \quad (2)$$

where  $\varepsilon$  is the price per unit of material, and  $m$  is the mass of material produced during the process.

For the production of 1 kWh of electricity, 1.290 kg of coal is consumed, while 0.194 kg of fly ash and 0.013 of bottom ash is generated [12]. The

mass of the electricity (main product) is calculated as the mass of equivalent coal:

$$m_{mainproduct} = 1.290 - 0.194 - 0.013 = 1.084 \text{ kg} \quad (3)$$

and the mass allocation coefficient  $C_{m,FA}$  is:

$$C_{m,FA} = \frac{0.194}{1.084 + 0.194} = 0.152 \quad (4)$$

The cost of fly ash and electricity in Serbia is 1.8€/ton and 0.025€/kWh, respectively. The economic allocation coefficient  $C_{e,FA}$  is then:

$$C_{e,FA} = \frac{0.194 \cdot \frac{1.8}{1000}}{1 \cdot 0.025 + 0.194 \cdot \frac{1.8}{1000}} = 0.014 \quad (5)$$

With the allocation coefficients  $C_{m,FA}$  and  $C_{e,FA}$ , the impacts of the primary process (electricity production) were allocated to FA production in the 'mass allocation' and 'economic allocation' case, respectively.

Type of concrete	Cement	Water	Aggregate		Fly ash	Super plastic.	w/c <sup>1</sup>	w/b <sup>2</sup>	Slump	Compress. strength
			Fine	Coarse						
			(river)	(recycled)						
			(kg/m <sup>3</sup> )				/	/	(cm)	(MPa)
RAC-FA0	308	185+39 <sup>3</sup>	593	1102	/	/	0.52	0.52	16	35.3
RAC-FA19	250	201+44 <sup>3</sup>	500	870	288	1.54	0.81	0.37	35 <sup>4</sup>	36.5
RAC_FA38	192	180+45 <sup>3</sup>	500	899	346	2.57	0.94	0.335	40 <sup>4</sup>	36.3

<sup>1)</sup> water-to-cement ratio

<sup>2)</sup> water-to-binder (cement+fly ash) ratio

<sup>3)</sup> additional water amount

<sup>4)</sup> flow value

Table 3: Mix proportions and properties of concrete.

Material	Route		Transport distance (km)	Transport type
	From	To		
River aggregate	Place of extraction	Concrete plant	100 x 2	Barge 10000 t
Cement	Cement factory	Concrete plant	100 x 2	Truck 16-32 t
Fly ash	Power plant	Concrete plant	50 x 2	Truck 16-32 t
Recycled aggregate	Recycling plant <sup>1</sup>	Concrete plant	100 x 2	Truck 16-32 t
Waste from recycling	Demolition site	Landfill	30 x 2	Truck 16-32 t
Mobile recycling plant <sup>2</sup>		Demolition site	200	Truck 16-32 t

<sup>1)</sup> Recycling is performed in mobile plant at demolition site

<sup>2)</sup> For each campaign of 2500 t the mobile plant (20 t) is transported at a distance of 200 km

Table 4: Transport distances and types.

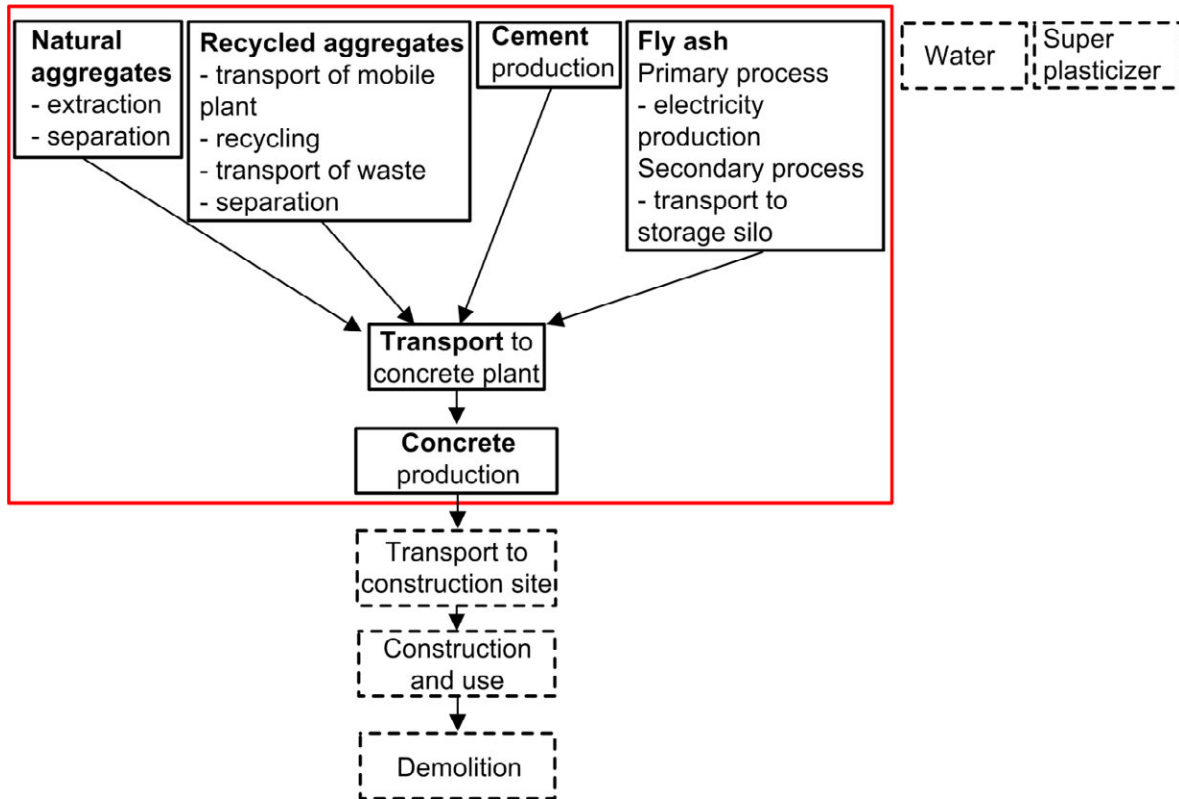

Fig. 1: Life-cycle of a concrete structure and system boundaries in the case study.

#### 4 RESULTS AND DISCUSSION

Calculated impact indicators in the 'no allocation', 'mass allocation' and 'economic allocation' case are shown in Figures 2, 3 and 4. Impact indicators of RAC\_FA19 and RAC\_FA38 are presented as percentage of RAC\_FA0 impact indicators.

It can easily be seen that in the 'no allocation' case all impacts of RAC with fly ash are lower than the impacts of RAC with no fly ash, the decrease being larger with a higher amount of FA. Results are different for other types of allocation since large quantities of airborne pollutants are emitted from coal power plants in the process of electricity production and even a small allocation coefficient can strongly affect FA impact indicators [16].

This is especially the case with 'mass allocation' because a relatively large mass of FA is generated during electricity production. In this case, all impacts of RAC with FA, except ozone layer depletion, are significantly higher than impacts of RAC with no FA, the increase being larger with higher amount of FA.

In the 'economic allocation' case results are more favourable for RAC with FA mostly because of the very low price of FA in Serbia. In this case all calculated impact indicators of RAC\_FA38 (except eutrophication where calculated values are approximately the same) are lower than the impact indicators of RAC with no fly ash. This decrease can be considered as significant since

it ranges from 3% to 38%, depending on the impact indicator. RAC\_FA19 has a somewhat higher (8% - 9%) eutrophication and acidification indicator than RAC\_FA0, while other indicators are lower than indicators of RAC with no FA.

#### 5 CONCLUSION

This case study was based on Serbian LCI data and typical conditions in Serbia. Within these limits, and for the chosen impact categories, it was concluded that FA application in recycled aggregate concrete can bring environmental benefits over cement application, but this depends on the applied type of allocation.

If mass allocation is applied, the FA environmental burdens become higher than the burdens of blended Portland cement and this can certainly discourage the producers to implement this material as cement clinker replacement. That's why the economic allocation is recommended since it results in much (several times) lower impacts of FA. Similar conclusions have been made by other researchers [16, 17] regarding the FA environmental impact when used as a mineral addition to concrete.

The important environmental benefit which is not accounted for in the CML methodology is the amount of waste materials used for the production of RAC with FA. Only 40% (35% if water is excluded) of RAC\_FA38 is made of natural resources, while 60% (65% if water is excluded) is made of waste – RCA and FA. Yet

this concrete can be used in structural applications where low-to-middle strength concrete is economically justified (for instance in residential buildings). This certainly contributes to the preservation of natural bulk resources and

landfill capacity, both becoming an important and scarce resource nowadays in many countries.

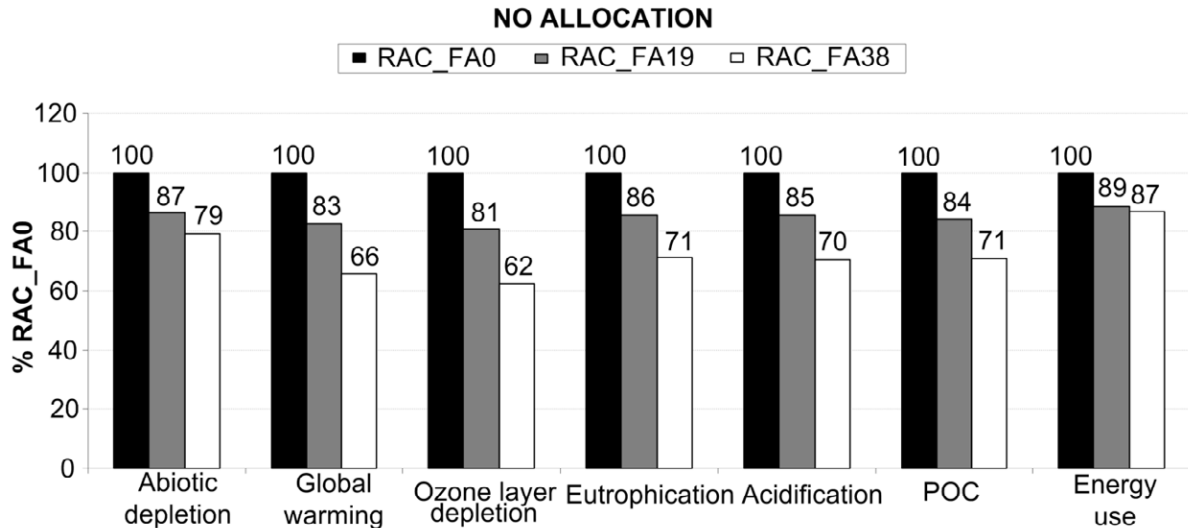

Fig. 2: Impact category indicators in 'no allocation' case.

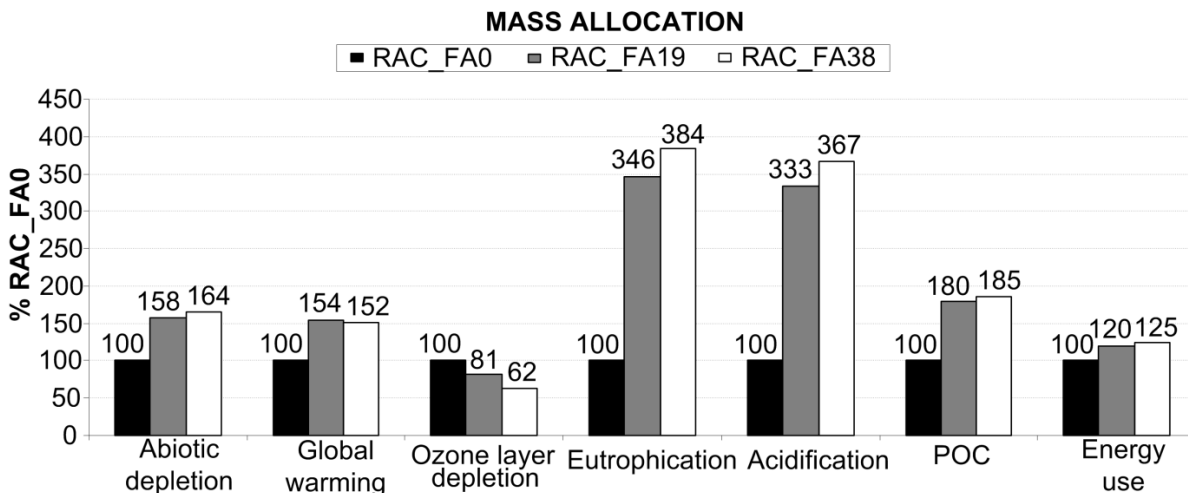

Fig. 3: Impact category indicators in 'mass allocation' case.

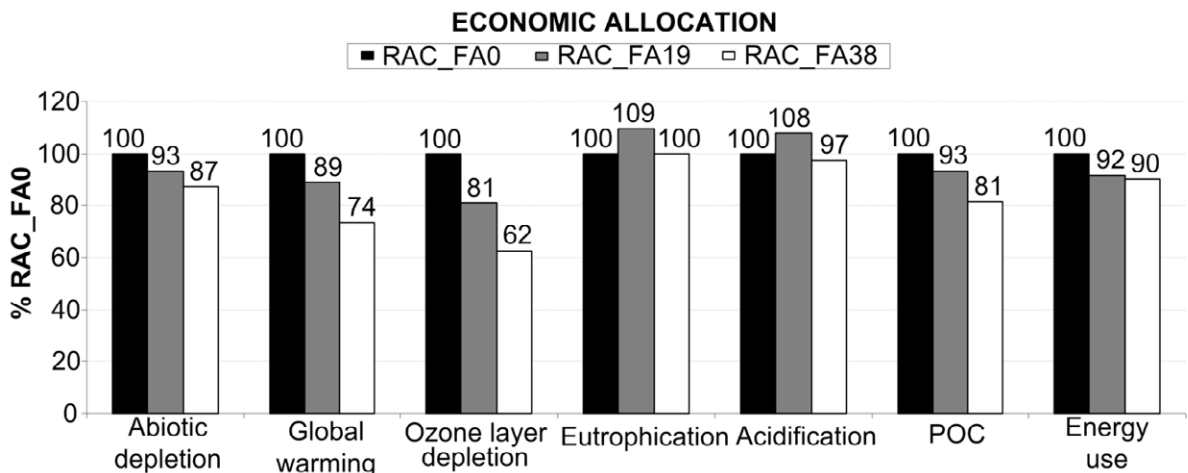

Fig. 4: Impact category indicators in 'economic allocation' case.

## 6 ACKNOWLEDGEMENTS

The work reported in this paper is a part of the investigation within the research project 152408 "Recycled aggregate and fly ash concrete: Economic and technologic study, From down cycling to urban ecology", supported by the Swiss National Science Foundation within the SCOPES programme. This support is gratefully acknowledged.

## 7 REFERENCES

- World Business Council for Sustainable Development (WBCSD), Concrete Recycling. The cement Sustainability Initiative, 2009. Available from: <http://www.wbcscement.org/pdf/CSI-RecyclingConcrete-FullReport.pdf> [Accessed 12 March 2012].
- C.S. Poon, L. Lam, Y.L. Wong, A study on high strength concrete prepared with large volumes of low calcium fly ash, *Cem. Concr. Res.* 30 (2000) 447–455.
- R. Siddique, Performance characteristics of high-volume Class F fly ash concrete, *Cem. Concr. Res.* 34 (2004) 487–493.
- C.H. Huang, S.K. Lin, C.S. Chang, H.J. Chen, Mix proportions and mechanical properties of concrete containing very high-volume of Class F fly ash, *Constr. Build. Mater.* (2013) 71–78.
- A. Ajdukiewicz, A. Kliszczewicz, Influence of recycled aggregates on mechanical properties of HS/HPC, *Cement and Concrete Composites* 24 (2002) 269–279.
- K. Rahal, Mechanical properties of concrete with recycled coarse aggregate, *Building and Environment* 42 (2007) 407–415.
- K.H. Yang, H.S. Chung, A. Ashour, Influence of type and replacement level of recycled aggregates on concrete properties, *ACI Materials Journal* 105 (2008) 289–296.
- S.C. Kou, C.S. Poon, Enhancing the durability properties of concrete prepared with coarse recycled aggregate, *Constr. Build. Mater.* 35 (2012) 69–76.
- EN 12620:2010 Aggregates for concrete, CEN-European Committee for Standardization, Brussels (2010).
- J.B. Guinée, M. Gorrée, R. Heijungs, G. Huppes, R. Kleijn, A. Koning, L. Oers, A.W. Sleeswijk, S. Suh, H. A. U. Haes, H. Bruijn, R. Duin, M.A.J. Huijbregts, Handbook on life cycle assessment. Operational guide to the ISO standards. I: LCA in perspective. IIa: Guide. IIb: Operational annex. III: Scientific background, Dordrecht, Kluwer Academic Publishers, 2002.
- S. Marinkovic, V. Radonjanin, M. Malesev, I. Lukic, Life Cycle Environmental Impact Assessment of Concrete, in L. Bragança, H. Koukari, R. Blok, H. Gervasio, M. Veljkovic, Z. Plewako, R. Landolfo, V. Ungureanu, L.S. Silva, P. Haller, Sustainability of Constructions – Integrated Approach to Life-time Structural Engineering. COST action C25. Proceedings of Seminar: Dresden, 6–7 October 2008. Possendorf, Herstellung, Addprint AG, 3.5–3.16.
- S. Jovanovic, TENT, Serbia, personal communication, 2015.
- R. Dones, C. Bauer, R. Bolliger, B. Burger, T. Heck, A. Roder, M.F. Emmenegger, R. Frischknecht, N. Jungbluth, M. Tuchschnid, Life Cycle Inventories of Energy Systems, Data v2.0 (2007),ecoinvent report No. 5, Villigen and Uster, 2007.
- M. Spielmann, C. Bauer, R. Dones, M. Tuchschnid, Transport Services, Data v2.0 (2007),ecoinvent report No. 14, Villigen and Uster, 2007.
- European Union. Directive 2008/98/EC of the European parliament and of the council on waste and repealing certain directives. *Off J Eur Union* L312 (2008) 3–30.
- C. Chen, G. Habert, Y. Bouzidi, A. Jullien, A. Ventura, LCA allocation procedure used as an incitative method for waste recycling: An application to mineral additions in concrete, *Resources, Conservation and Recycling* 54 (2010) 1231–1240.
- P. Van de Heede, N. De Belie, Environmental impact and life cycle assessment (LCA) of traditional and 'green' concretes: Literature review and theoretical calculations, *Cement and Concrete Composites* 34 (2012) 431–442.







## Expanding Boundaries: Systems Thinking for the Built Environment

### ECO-EFFICIENCY OF CONSTRUCTION AND DEMOLITION WASTE RECYCLING IN CHONGQING, CHINA

Jiangbo Wu<sup>1\*</sup>, Mingming Hu<sup>1,2</sup>, Shiyong Shi<sup>1</sup>, Tingting Liu<sup>1</sup>, Chunbo Zhang<sup>1</sup>

<sup>1</sup> Chongqing University, School of Construction Management and Real Estate, 400045  
Chongqing, China

<sup>2</sup> Leiden University, Institute of Environmental Sciences (CML), 2333 CC Leiden, the  
Netherlands

\*Corresponding author; e-mail: wujiangbo09@163.com

#### Abstract

Ongoing urbanization along with increased regeneration of the obsolete city centres makes the recycling of Construction and Demolition Waste (CDW) an ever hot topic to realize China's circular economy strategy in its construction industry. However, the current recycling rate of CDW is only 5% in the country and the recycling industry is in its infant stage. How to recycle the CDW in a more cost effective and environmentally beneficial way, given the opportunity of the underdeveloped CDW recycling system in China, is a key issue to be investigated at this moment.

From a life cycle perspective, eco-efficiency analysis is used in this study to systematically evaluate the potential pros and cons for developing the different types of CDW treatment and recycling systems to be developed in Chongqing. Nowadays, two forces are driving the development of the CDW recycling industry in China: one is from grass-root – e.g. around 20 small private recycling plants have been established in Chongqing in the last decade, and another is from top-down – e.g. billions of Chinese RMB have been spent to build a group of state-owned large CDW recycling centres. The case study shows, properly designed, the eco-efficiency analysis is able to identify the hot spots and trade-offs between economy and environment systems.

#### Keywords:

Construction and Demolition Waste; Eco-efficiency; Chongqing

#### 1 INTRODUCTION

The urbanization rate in China is expected to hit 60% by 2018. A great number of Construction and Demolition Waste (CDW) will be produced with the old city regeneration and new city construction. However, direct CDW landfilling is still dominating this country, rendering the recycling of CDW at a rate of 5% and the recycling industry in its infant stage. How to recycle the CDW in a more cost effective and environmentally beneficial way, given the opportunity of the underdeveloped CDW recycling system in China, is a key issue to be investigated at this moment.

Eco-efficiency, first introduced by the World Business Council for Sustainable Development (WBCSD [www.wbcsd.org](http://www.wbcsd.org)), is considered useful

for guiding micro-level actions towards sustainability [1]. The concept describes a vision of creating more goods and services with less resources and waste. It provides a new perspective for the search of cost effective and environmentally sound solutions for the waste management issues. Quite a few Chinese researchers attempted to use the eco-efficiency concept to support waste management decision making. Lu analysed the eco-efficiency of two different recycling strategies of WEEE (Waste Electrical and Electronic Equipment) in China [2]. Zhao applied a quasi-dynamic eco-efficiency model to analyse the municipal solid waste management and concluded that the eco-efficiency of an integrated scenario is potentially better [3]. Huang qualitatively discussed the legal regulation of the reduction and utilization of the

CDW under the guidance of the principle of eco-efficiency [4]. However, few quantitative eco-efficiency studies, especially well recorded ones, can be found on the CDW treatment in China.

In this paper, we present an eco-efficiency analysis for four CDW treatment scenarios in Chongqing, China, which is quantified by the environmental impact index obtained from life cycle assessment (LCA) and the economic index obtained from life cycle costing (LCC). Based on this, the development direction for eco-efficient recycling CDW in Chongqing is recommended.

## 2 MATERIALS AND METHODS

### 2.1 CDW Treatment Scenarios

According to our field survey, there are three main routes for the CDW treatment in Chongqing at present.

**Route I:** Simple landfill. If landfill sites are close to the construction sites, contractors will send the CDW for direct landfilling to save disposal cost.

**Route II:** Private recycling. Private recycling of CDW in Chongqing has existed since the 1990s. They all run at small scale. Most are located close to the urban centres under regeneration. According to the information provided by Chongqing Wall Materials Industry Association, there are about 20 private enterprises handling CDW recycling in the central urban area of Chongqing. And more than one hundred private enterprises engage in the CDW recycling in Chongqing, whose annual output value is close to 200 million RMB.

**Route III:** State-owned recycling. The plan approved by the municipality includes the construction of 7 CDW recycling centres. Constrained by the land availability, the first two state-owned recycling centres were finally established at the beginning of 2015 in the urban fringe areas. The state-owned waste management company, Chongqing Environment and Sanitation Group, is responsible for the option of both plants. But due to the long transport distance from city centres (50 – 80 km), both plants are suffering from a lack of CDW supply at the moment.

Through interviews with experts and the comparison with several data sources, we find the most reliable estimation of the amount of CDW generation in Chongqing 2014 is 6.1212 million tons, which was treated by landfill (5.0473 million tons; 82.4%), private recycling (0.5739 million tons; 9.4%) and state-owned recycling (0.5 million tons; 8.2%) [5]. According to this proportion we analysed the eco-efficiency of the current CDW treatment status of Shapingba district in Chongqing.

As you can see in Figure 1, four scenarios are analysed based on the above field investigation. In addition to the current CDW treatment status

(hybrid), three other scenarios, representing maximizing one of the single CDW treatment route are formulated. In order to make a fair comparison, a basket of function approach is taken, considering the generation of the construction materials (concrete bricks) from the systems under study. The four scenarios are:

- Landfill Scenario. Put all CDW into simple landfill, and use conventional concrete bricks in the subsequent construction process.
- Private Recycling Scenario. Put all CDW into private recycling plants, and put some extra new materials in the process of producing recycled concrete bricks, then use the recycled concrete bricks.
- State-owned Recycling Scenario. Put all CDW into state-owned recycling centres, and use the waste material for reproduction as much as possible, then utilize the recycled concrete bricks.
- Hybrid Scenario. Hybrid process includes the above three scenarios (current status).

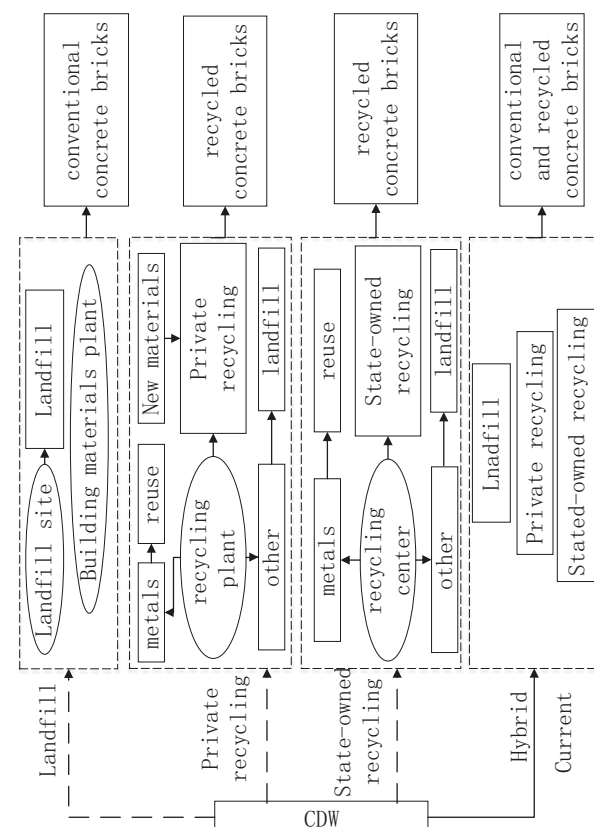

Fig. 1: Four CDW treatment scenarios in Chongqing.

### 2.2 System borders

On the condition of treating the same amount of CDW, the output of private recycling plants is much more than the output of state-owned recycling centres because private recycling plants add new materials in the production process of recycled concrete bricks. If the CDW is dumped, we have to use the primary materials to produce conventional concrete bricks. We use the treatment of 0.5739 million tons CDW as the

base to analyse the eco-efficiency of the CDW treatment scenarios.

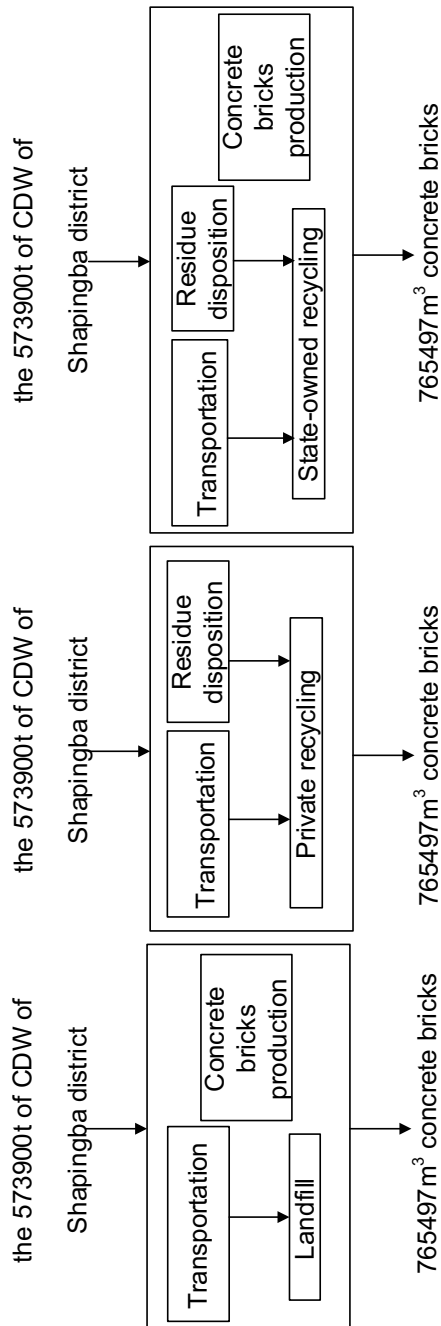

Fig. 2: The system boundary of the three single scenarios.

In consideration of the current hybrid CDW treatment scenario in Chongqing, on the basis of analysing the three single scenarios, firstly, we analyse the eco-efficiency of the current scenario.

The determination of system borders is a key to system modelling [6]. In consideration of the function of system which is urban CDW treatment and concrete bricks production simultaneously, we decide to expand the system boundary to analyse environment impacts of different scenarios above. The main processes of every system are transportation, CDW treatment,

residue disposition and concrete bricks production. The system boundary of the three single scenarios is shown in figure 2.

### 2.3 Environment impact

Global warming has become a widely concerned problem at present. The data shows that construction industry is one of the world's three largest sources of the greenhouse gases, which consumes 40% of global energy and produces 36% of greenhouse gas emission [7]. However, the greenhouse gas emission in the construction materials production and CDW treatment stage is 18.3% of life cycle emission [8]. How to reduce it has become a problem that cannot be ignored. So we have chosen carbon dioxide equivalent as environmental impact index when using LCA to assess the environment impact of system. The main production data are shown in table 1.

Category	Landfill	Private recycling	State-owned recycling
CDW (t)	573900	573900	573900
recycled concrete bricks (m <sup>3</sup> )	0	765497	196999
conventional concrete bricks (m <sup>3</sup> )	765497	0	568498
residue (kg)	0	54515010	55251545

Tab.1: The main production data.

Metal scraps are main co-products in the systems above. So allocation of environment impact of different products will be discussed. The proportion of metal scraps is only 0.16% in total of CDW. The ratio of recycle of metal scraps and production of concrete bricks is small no matter from the perspectives of economic cost or physical weight during the concrete bricks production. And there is little difference between the two. In addition, the weight of metal scraps has a strong effect on its economic cost. Here we choose to allocate from the perspective of physical weight.

### 2.4 Economic cost

The economic cost of different treatment scenarios was carried out using LCC. According to the characteristics of the CDW production process and the principle of "who produce who responsible for", the economic cost of different treatment scenarios can be divided into internal cost and external cost. The internal cost is counted from the perspective of contractor. The external cost refers to the social and environmental costs caused by treating the CDW.

The internal and external cost structure of different treatment scenarios and the main parameter values are shown in table 2 and table 3. Internal cost of three single scenarios is corresponding transportation fee and the gate fee for contractors. Landfill leads to environmental pollution which can be avoided through recycling. We found that there is a lot of dust emission

caused by private recycling, but dust emission caused by state-owned recycling is little. We can avoid environmental pollution caused by landfill by using state-owned recycling to instead landfill. So external cost of landfill is conventional concrete bricks production cost and the part of state-owned recycling cost exceeding the gate fee of landfill site. External cost of private recycling is the part of private recycling cost exceeding the gate fee of private recycling plant and environmental cost of air pollution caused by dust. External cost of state-owned recycling is concrete bricks production cost and the part of state-owned recycling cost exceeding the gate fee of state-owned recycling plant.

Category	Formula	Remarks
Landfill	Internal cost:	W: amount of CDW
	$C_{11} = W \times D_x \times T_x + R_x \times W$	D <sub>x</sub> : distance to landfill site T <sub>x</sub> : unit transportation cost of landfill site R <sub>x</sub> : the gate fee of landfill site
	External cost:	Z <sub>g</sub> : state-owned recycling unit cost
Private recycling	$C_{12} = (Z_g R_x) \times W + C_z \times Q_z$	C <sub>z</sub> : unit manufacture cost of conventional concrete bricks Q <sub>z</sub> : amount of conventional concrete bricks for landfill
	Internal cost:	D <sub>m</sub> : distance to private recycling plant
	$C_{21} = W \times D_m \times T_m + R_m \times W$	T <sub>m</sub> : unit transportation cost of private recycling plant R <sub>m</sub> : the gate fee of private recycling plant
State-owned recycling	External cost:	Z <sub>m</sub> : private recycling unit cost
	$C_{22} = (Z_m R_m) \times W + C_a$	C <sub>a</sub> : unit environmental cost of air pollution
	Internal cost:	D <sub>g</sub> : distance to state-owned recycling center
	$C_{31} = W \times D_g \times T_g + R_g \times W$	T <sub>g</sub> : unit transportation cost of state-owned recycling center R <sub>g</sub> : the gate fee of state-owned recycling center
	External cost:	Z <sub>g</sub> : state-owned recycling unit cost
	$C_{32} = (Z_g R_g) \times W + C_z \times (Q_z - Q_g)$	Q <sub>g</sub> : amount of concrete bricks for state-owned recycling

Tab.2: The cost composition of the three single scenarios.

The environmental cost of air pollution is calculated with a corrected human capital method. In 2009, the national per capita GDP was 25545.36 RMB, the cost of treatment for each patient suffering from chronic bronchitis was 45272.4 RMB [9]. So on condition of per capita GDP of Chongqing was 48031 RMB in 2014 [5], the cost of treatment for each case of chronic bronchitis was 84441.29 RMB. With the exposure-response relationship function, 934 people can avoid to chronic bronchitis when the PM10 concentration is reduced to threshold, 20

ug/m3 put forward by the World Health Organization(WHO). The external health cost caused by air pollution is 78868167.09 RMB.

Parameters	Values	Unit
D <sub>x</sub>	20 <sup>a</sup>	km
D <sub>m</sub>	8 <sup>b</sup>	km
D <sub>g</sub>	50 <sup>b</sup>	km
T <sub>x</sub>	1.21 <sup>c</sup>	RMB·t <sup>-1</sup> ·km <sup>-1</sup>
T <sub>g</sub>	1.11 <sup>c</sup>	RMB·t <sup>-1</sup> ·km <sup>-1</sup>
T <sub>m</sub>	1.48 <sup>c</sup>	RMB·t <sup>-1</sup> ·km <sup>-1</sup>
R <sub>x</sub>	2.5 <sup>d</sup>	RMB·t <sup>-1</sup>
R <sub>m</sub>	3 <sup>b</sup>	RMB·t <sup>-2</sup>
R <sub>g</sub>	25 <sup>e</sup>	RMB·t <sup>-3</sup>
Q <sub>z</sub>	765497 <sup>b</sup>	m <sup>3</sup>
Q <sub>g</sub>	196999 <sup>e</sup>	m <sup>3</sup>
Z <sub>g</sub>	64.97 <sup>e</sup>	RMB·t <sup>-1</sup>
Z <sub>m</sub>	289.27 <sup>b</sup>	RMB·t <sup>-2</sup>
C <sub>z</sub>	302.76 <sup>b</sup>	RMB/m <sup>3</sup>
C <sub>a</sub>	78868167.09	RMB

Tab.3: The main parameter values.

- <sup>a</sup> Site layout planning for landfill station of the main urban area of Chongqing
- <sup>b</sup> Field investigation
- <sup>c</sup> Converted from building engineering budget ration of Chongqing
- <sup>d</sup> Paid service charge management regulation of Urban environmental sanitation of Chongqing
- <sup>e</sup> Feasibility study report on CDW treatment project of the main urban area of Chongqing

### 2.5 Eco-efficiency

Eco-efficiency, as a quantitative sustainability analysis tool developed in the field of industrial ecology in recent years, is increasingly applied to the decisions of European Union environmental management [10]. It contains two dimensions of sustainable development of environment and economy, and its purpose is to encourage enterprises to develop production, improve the economic benefit and undertake the responsibility of environment protection to the whole society. All these exactly conform to the development direction of 'Reduction and Recycling' in China.

The formula for calculation is as follow:

$$\text{Eco - efficiency} = \frac{\text{Environment impact}}{\text{Economic cost}} \quad (1)$$

The environment impact will be assessed with LCA and the economic costs will be given with LCC [11].

The eco-efficiency relative change between different scenarios should be given while using the eco-efficiency analysis to make effective decisions. The eco-efficiency of the above formula is a one-dimensional quantity determined

by the environment impact and economic cost. For multiple comparison modes, comprehensive and effective information cannot be shown if we just use the formula. As a result, we use graphic method to compare eco-efficiency of different scenarios [12]. As is shown in figure 5, in order to make the results of the study more helpful for policymakers, one of scenarios is chosen as the benchmark, which is shown with coordinate origin. The value of x-coordinate expresses the relative value in the aspect of environmental impact. The value of y-coordinate expresses the relative value in the aspect of economic cost. Then we can clearly know that the closer to the top right corner of coordinate system the program is, the higher eco-efficiency of the program is.

**3 RESULTS**

**3.1 LCA of different scenarios**

In order to make the result more accurately reflect the reality of China, we use the eBalance software and China Life Cycle Database (CLCD) developed by Sichuan University to calculate the greenhouse gas emission [13]. However, there is no landfill data set in the CLCD, so we invoke the corresponding data set of the Ecoinvent. On the condition of treating 573900t CDW and producing 765497m<sup>3</sup> concrete bricks, the greenhouse gas emission of four scenarios is shown in figure 3.

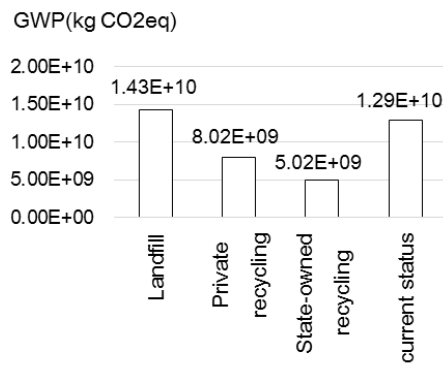

Fig. 3: The greenhouse gas emission of four scenarios.

**3.2 LCC of different scenarios**

By substitution of the main parameter values in table 3 into the formula in table 2, the internal and external cost structure of different treatment scenarios is calculated. The result is shown in figure 4.

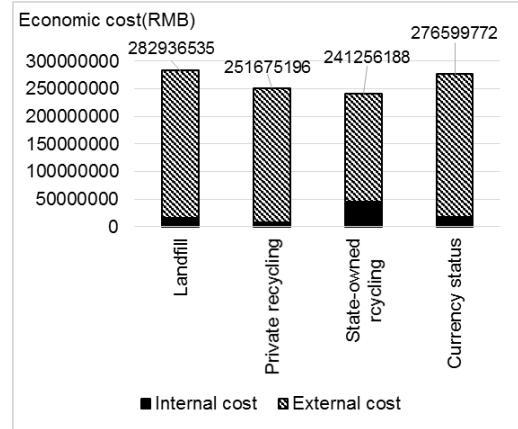

Fig. 4: The economic cost of four scenarios.

**3.3 Eco-efficiency of different scenarios**

The current CDW treatment scenario is chosen as the benchmark of eco-efficiency analysis and three single scenarios are treated as comparison schemes. Based on the results of LCA and LCC above, the result of eco-efficiency analysis can be shown in figure 5.

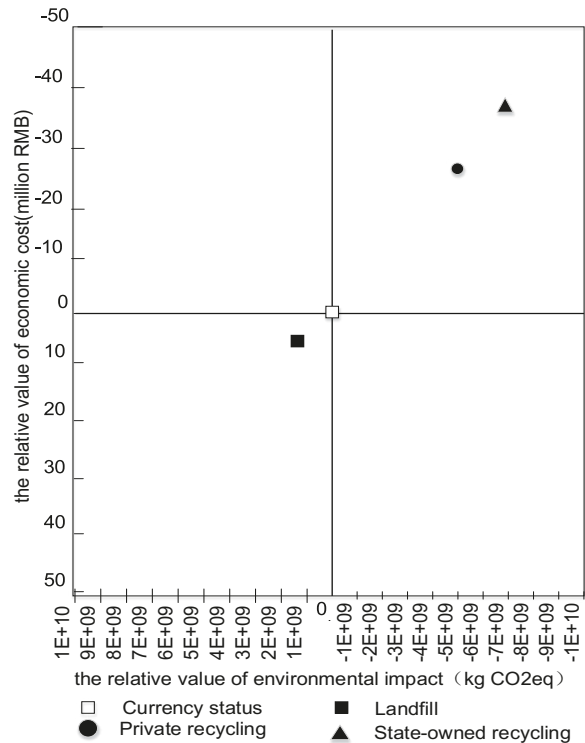

Fig.5 The result of eco-efficiency analysis.

**4 DISCUSSION**

Figure 5 shows that the eco-efficiency of recycling is higher than landfill, and the eco-efficiency of state-owned recycling is higher than private recycling. Figure 3 shows the greenhouse gas emission of state-owned recycling is the lowest. Compared with private recycling, the emission of state-owned recycling decreased by 37%. Compared with landfill, the emission of state-owned recycling decreased by 65%. Figure 4 shows that recycling can save tens of million

RMB than landfill. External cost takes quite a large proportion in economic cost of three scenarios, which is produced by the environmental impact. From the prospective of society, it should be concerned especially in the period of overall ecological civilization construction in China. State-owned recycling makes total cost and external cost decrease simultaneously. However, the internal cost of state-owned recycling is highest for contactors. Its main reason is the difference of transportation distance.

Figure 5 also shows that the level of eco-efficiency of current status is relatively low. Compared with the eco-efficiency of current status and landfill, the eco-efficiency of landfill is lowest. It draws a conclusion that landfill is a route that is not only uneconomic but also environment-polluted. When the CDW recovery rate is improved, the eco-efficiency is also improved. It means that recycling is helpful to improve the eco-efficiency of the CDW treatment. Compared with the eco-efficiency of current status and recycling (private or state-owned recycling), the CDW treatment route still has enough space for improvement in the aspect of eco-efficiency.

## 5 CONCLUSION

After analysing the eco-efficiency of three treatment scenarios and the current status, we can see that the current CDW treatment status in the central urban area of Chongqing is relatively backward, no matter in the aspect of economic cost or environmental impact. By contrast with the results of the early landfill of all and the now recycling of part, it can be seen that there is no doubt that landfill cannot be a future solution to treat the CDW. It has the biggest environmental and cost burden. The results show encouraging both private and state-owned recycling can improve the eco-efficiency of CDW treatment in Chongqing. However, the saving potential of state-owned recycling centre is even bigger. The governors should do more efforts to locate the future state-owned recycling centres closer to future CDW intensive areas and facilitate the current two plants in full use with sufficient supply of CDW. It is also necessary to improve the twenty private recycling plants so that they can be more normative and environment-friendly. Besides, from the vision of those private recycling plants, it's more profitable if they find out causes of inefficiencies in production.

## 6 REFERENCES

1. Huppel G, and Ishikawa M., Eco-efficiency guiding micro-level actions towards sustainability: Ten basic steps for analysis. *Ecological Economics*, 2009, 68(6): p. 1687-1700.
2. B. Lu and J. X. Yang, Eco-efficiency analysis of recycling strategies of WEEE in China. *Chinese Journal of Environmental Engineering*, 2010. 4(1): p. 183-188.
3. W Zhao, Huppel G, Voet E. V. D. Eco-efficiency for greenhouse gas emissions mitigation of municipal solid waste management: A case study of Tianjin, China. *Waste Management*, 2011, 31(6): p. 1407–1415.
4. X.S. Huang and B.X. Xu, On the Legal Regulation of the Reduction and Utilization of the Construction Waste Based on Eco-Efficiency. *Urban Studies*, 2011. 18(9): p. 90-94.
5. Chongqing Statistic Bureau, *Chongqing Statistical Yearbook-2014*. 2014, Beijing: China Statistics Press.
6. J.X. Yang, *Methodology and application of life cycle assessment*. 2002, Beijing. China: meteorology Press.
7. Change I P O C. *Climate Change 2007: Synthesis Report*. Environmental Policy Collection, 2007, 27(2):408.
8. S.C. Yin, *Study of life-cycle carbon emission in buildings*. 2012, Harbin. China: Harbin Institute of Technology.
9. X.Q. An, et al., Evaluation on economic loss of human health induced by Inhalable Particulate Matter in 2009 in China, in 29th Annual Meeting of Chinese meteorological society. 2012: Shenyang, China. p. 2-6.
10. Huppel G. and Ishikawa M., *Quantified Eco-Efficiency: An Introduction with Applications*. 2007, Dordrecht. Netherlands: Springer Netherlands.
11. Steen B., Environmental costs and benefits in life cycle costing. *Management of Environmental Quality: An International Journal*. 2005, 16(2): p. 107-118.
12. Huisman J., *The QWERTY/EE concept*. 2003, Delft, Netherlands: Delft University of Technology.
13. X. L. Liu., et al., Method and basic model for development of Chinese reference life cycle database of fundamental industries. *Acta Scientiae Circumstantiae*, 2010, 30(10): p. 2136 – 2144.



## Expanding Boundaries: Systems Thinking for the Built Environment

### EFFICIENCY OF USING RECYCLED FINE AGGREGATE FOR A NEW CONCRETE

A. Katz<sup>1\*</sup>, D. Kulisch<sup>1</sup>

<sup>1</sup> Faculty of Civil and Environmental Engineering, Technion – Israel Institute of Technology, Haifa 32000, Israel

\*Corresponding author; e-mail: akatz@technion.ac.il

#### Abstract

Using construction and demolition waste (C&DW) as a source for aggregates draws attention lately due to the large quantities of C&DW accumulating in the modern world. The coarse fraction of this waste was studied extensively in the past as a source for coarse aggregates in the production of new concrete. It is quite acceptable that replacing 10-20% of the virgin coarse aggregate with recycled one will have a minor effect on the properties of the new concrete. However, using the fine fraction of C&DW to replace virgin aggregate is still in question and is restricted in the standards.

In the study presented here the fine fraction of C&DW from two sorting plants was used to prepare new mortar and to replace natural sand crushed from natural stone. Two water/cement ratios were studied with three replacement ratios of 0%, 30% and 100%. The results showed that the mortars prepared with the recycled fine aggregates were inferior to the mortar prepared with virgin aggregate. The compressive strength has reduced and the permeability increased. It was found that reducing the water/cement ratio from 0.6 to 0.4 can preserve the compressive strength of the mix while replacing 100% of one of the aggregates studied. Similarly, the equivalent water/cement ratio was evaluated for the other aggregates and replacement ratios. These relationships can be used to evaluate the environmental efficiency of using recycled fine aggregates from C&DW for making new concrete.

#### Keywords:

Recycled fine aggregate; concrete; strength; permeability

## 1 INTRODUCTION

Recycled aggregate from construction and demolition waste (CDW) accumulates in large quantities worldwide. The amount of waste is estimated at 0.5-1.0 ton/capita/year depending on the degree of industrialization and whether waste from infrastructure works is included [1]. The largest portion of the waste is granular material arising from old concrete, mortar, bricks, soil, stones etc.

Thus, for example, Katz and Baum [2] found that large parts of the waste generated in the construction of the frame of a building is composed of granular material that has a potential for recycling. Indeed, most of the standards worldwide enable the use of coarse recycled aggregate but the use of the fine fraction is accompanied by caveats [3]. Recycled fine

aggregated was tested in some studies [4-8] but the results were mixed though in most cases the properties of the new concrete were inferior to concrete made with natural aggregates.

In this study the properties of mortar made with recycled aggregate derived from regional recycling plants were evaluated and conclusions were derived as for its use in the production of new concrete.

## 2 MATERIALS AND METHODS

Recycled aggregates were collected from two recycling plants. These plants are located in different regions of the country. In both plants the waste stream is inspected and coarsely sorted first to remove organic matter and green waste and then crushed and sieved to produce coarse (>5 mm) and fine (<5 mm) aggregate. The fine

aggregate from either plant was labelled as RA-3 and RA-4. The initial inspection in the plant producing RA-3 is more stringent than in the other plant. In addition, RA-3 is further treated by washing and precipitation to yield RA-1, a fine fraction, and RA-2, a coarse fraction. Natural crushed sand was used as a reference sand.

Two water/cement ratios were tested: 0.4 and 0.6 in 3 replacement ratios of 0%, 30%, and 100%. Mix composition was 1:0.4 (or 0.6):2 of cement:water:sand. CEM I 52.5N complying with EN 197, was used in all the mixes.

### 3 RESULTS

#### 3.1 Aggregate properties

Aggregates' grading is shown in Fig. 1. It seems that the recycled aggregates as derived from the waste stream (RA-3 and RA-4) are somewhat finer than the reference natural crushed sand. RA-3 contains more fine particles in the range of 0.15 to 0.3 mm than RA-4 but the other particle distribution is quite similar. Additional treatment to RA-3 separates the fine fraction to RA-1 that contains mostly 0-0.3 mm particles and RA-2 that contains mostly particles of 1.18-9.5 mm. All the aggregates were sieved over 4.75 mm before making the mortars to produce sand that is smaller than 4.75 mm.

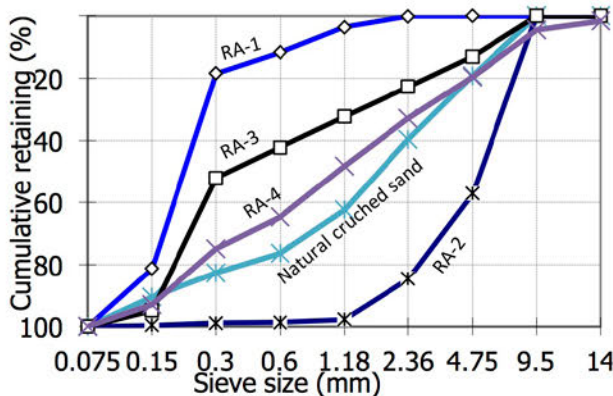

Fig. 1: Aggregates' grading.

Additional aggregate testing indicated that RA-1 is composed mostly from quartz particles with little amount of fines (particles smaller than 75 $\mu$ m) whereas RA-2 is made from natural aggregates glued together with hardened cement paste (both are derived from RA-3). Aggregate RA-4 is made of crushed natural limestone or dolomite with hardened cement paste. These differences stem from the different geographical regions of these two recycling plants, representing the typical construction materials in these regions.

Aggregates RA-2, RA-3 and RA-4 contained relatively large quantities of old cement past identified by relatively large water absorption values, lower density and microscope observations. RA-1 was relatively clean from old

cement paste but its properties were somewhat lower than natural aggregate.

An interesting finding from other tests is the presence of green waste, as was found by thermal gravimetric analysis.

#### 3.2 Properties of the hardened mix

The compressive strength of the hardened mixes was tested at 3, 7 and 28 days. The results of mixes prepared with w/c ratio of 0.4 and with 100% replacement ratio are presented in Fig. 2 and Fig. 3 presents the results of w/c=0.6.

The results clearly demonstrate that replacing the natural sand with sand produced in recycling plant significantly reduce the compressive strength. Aggregate RA-4, which was produced at the lowest quality, demonstrated the lowest quality with a strength reduction of ~50% compared with mixes with natural aggregate. The second source of aggregate, RA-3, demonstrated better performances, though, only slightly better. The effect of secondary treatment is clearly seen by the better performances of RA-2 and RA-1 which are made from RA-3. RA-1 presents the highest quality among the recycled aggregates but full replacement of the natural aggregate with this one led to a significant reduction of strength as can be seen Fig. 2 and Fig. 3.

The effect of aggregate replacement on the strength was different in the two water/cement ratios tested. At the low w/c (0.4) the compressive strength has reduced by 34% compared with mortar made with natural aggregate, whereas at higher w/c (0.6) the reduction was of only 19%. This phenomenon is quite known from lightweight aggregate concrete in which the strength reduction becomes larger when the difference between the aggregate quality and paste quality becomes larger.

At the early age of 3 days all the lower quality aggregates, i.e. RA-2, RA-3 and RA4, demonstrated similar strength in each of the w/c ratios, resulting probably from the lower quality together with low properties of the new cement paste.

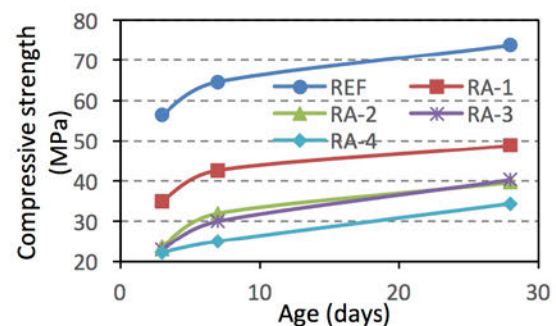

Fig. 2: Development of compressive strength of w/c=0.4 and 100% replacement ratio.



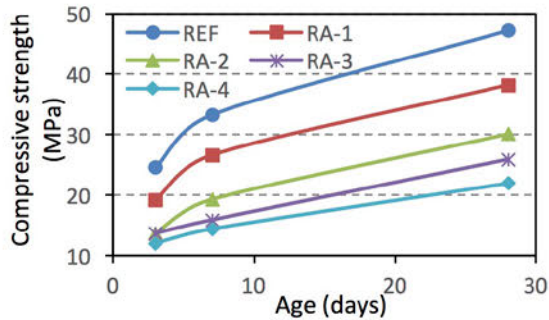

Fig. 3: Development of compressive strength of  $w/c=0.6$  and 100% replacement ratio.

Lower replacement ratio of 30% showed that the properties of the mixes were inferior to those of the reference mixes with natural aggregate only (REF, see Fig. 4), however to less extent when comparing with strong effect at 100% replacement ratio. In-fact, the effect of using aggregate RA-1 was minor, a reduction of only 3% and 9% was identified at the lower or higher  $w/c$  ratios, respectively. RA-2 exhibited some strength reduction at the lower  $w/c$  but similar strength as RA-1 at the higher  $w/c$ . More strength reduction was seen when RA-3 and RA-4 were used (Fig. 4).

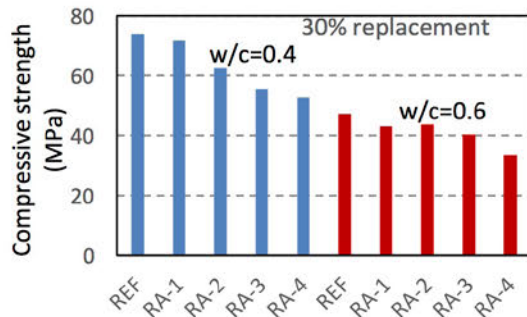

Fig. 4: Compressive strength at 28 days with replacement ratio of 30%.

Diffusion was measured by the Torrent method [9] using 50 mm thick discs with a diameter of 200 mm. The absolute results indicated poor to very poor performances (indices of 4-5) of all mixes thus the results were normalized with respect to the reference mix with natural aggregate only (REF) in each of the  $w/c$  tested. The results are presented in Fig. 5. It appears that replacing the natural aggregates with recycled ones increased the air permeability of the mortars tested. The smallest effect was identified in RA-1 with permeability increase of 75% and 20% at  $w/c=0.4$  and 0.6, respectively. The largest influence was identified with RA-2 with 700% and 300% increase, respectively.

Two parameters seem to control the influence of aggregates replacement: the amount of old cement paste adhered to the recycled aggregate; and the difference between the properties of the new cement paste and the old paste. Air

penetration is related to the total content of paste, thus increased amount of paste, from the old and new paste, is expected to increase the air permeability. However, differences between the two pastes, new and old, may also affect the permeability, leading to a more significant effect when air can penetrate easily through the particles with the old paste.

This phenomenon was more evident with aggregate RA-2 that contained significant amounts of old paste thus exhibiting the largest changes.

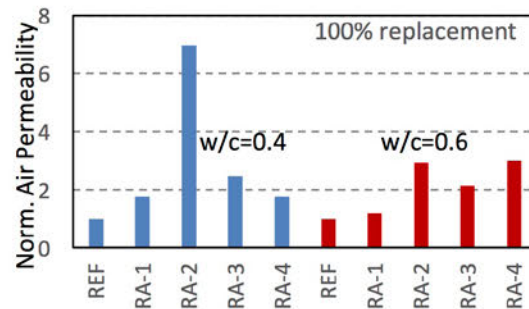

Fig. 5: Normalized air permeability results for full replacement of the aggregates.

### 3.3 Efficiency of mixes with recycled aggregates

The efficiency of mixes with recycled aggregates was measured by the reduction required in the water/cement ratio to maintain the same property as obtained with natural aggregates. This is demonstrated in Fig. 6 that presents the results of compressive strength vs. water/cement ratio together with a regression line connecting between these results (REF and 30% aggregate replacement). It is clear that it is possible to preserve the compressive strength obtained with natural aggregates while replacing the aggregates with recycled ones but adjustment of the water/cement ratio is needed. It can be seen that the compressive strength of 47 MPa obtained in  $w/c=0.6$  and with 100% natural aggregate is achieved when lowering the  $w/c$  to 0.56 for aggregates RA-1 and RA-2 and to lower values of 0.50 and 0.45 for RA-3 and RA-4, respectively.

The effect of 30% aggregate replacement on air permeability is demonstrated in Fig. 7. The same level of air permeability of the reference mix prepared with  $w/c=0.6$  is maintained if the  $w/c$  ratio is reduced to 0.57 to 0.55 for aggregates RA-1 to RA-4. Practically, about the same  $w/c$  for all the aggregates.

It appears that the effect of replacing recycled fine aggregates with natural aggregates is different when different properties are considered. When 30% replacement rate was analysed the effect on compressive strength was large and in a wide range depending on the

properties of the individual recycled aggregate. The effect on air permeability, on the other hand, was much smaller with small differences between the aggregates.

This way, the value, both financial and environmental, of using the recycled aggregates can be calculated. Lowering the water/cement ratio requires an increase in the cement content in these mixes while preserving the same amount of water that is required to maintain workability. For example, lowering w/c from 0.6 to 0.45 as required in order to preserve the compressive strength when 30% of the aggregate is replaced with RA-4 leads to an increase of 33% in the cement content. Its environmental impact as well as its cost can be calculated and the worthiness of this act can be assessed.

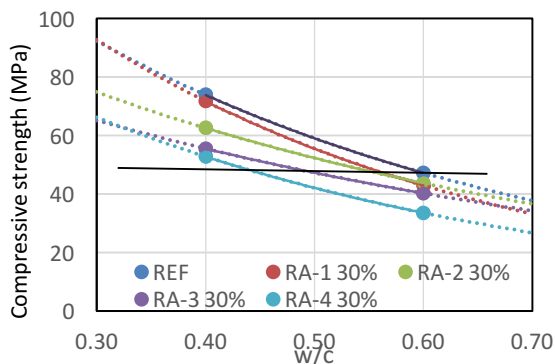

Fig. 6: Efficiency of 30% aggregate replacement - Strength.

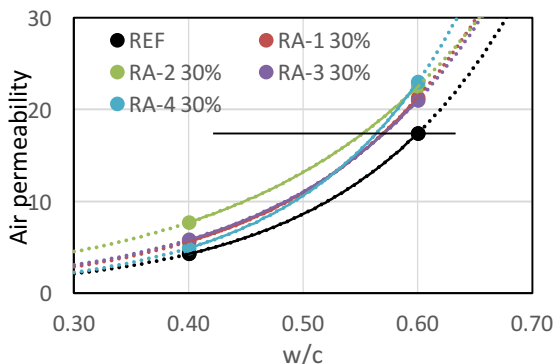

Fig. 7: Efficiency of 30% aggregate replacement - Air permeability.

#### 4 SUMMARY AND CONCLUSIONS

The properties of recycled fine aggregate from construction and demolition waste were tested together with its impact on the properties of new concrete prepared at water/cement ratios of 0.4 and 0.6.

The aggregates derived from the recycling plants were of lower quality compared with new aggregates. It was clear that beneficiation processes can improve its properties but not

back to its initial properties. The mechanical properties (compressive strength) and durability (air permeability) are inferior by up to 50% compared with mixes prepared with natural aggregates.

It is possible to compensate for the reduced properties by lowering the water/cement ratio. The reduction is different for different source of aggregate or different property. For example, w/c of 0.45 is needed to preserve the compressive strength of a mix prepared with w/c of 0.6 when RA-4 replaces 30% of the aggregates, but a reduction of w/c to 0.55 only is needed in order to maintain the air permeability. The monetary and environmental cost can be calculated this way.

#### 5 ACKNOWLEDGMENTS

The authors warmly acknowledge partial support from the Ministry of Construction and Housing.

#### 6 REFERENCES

1. Monier, V. et al, Study on the management of construction and demolition waste in the EU, Final report for the European Commission (DG Environment) 2011.
2. Katz, A. and Baum, H., A novel methodology to estimate the evolution of construction waste in construction sites, Waste management, 2011, 31(2), pp. 353-358.
3. EN 12620, Aggregates for Concrete, European Committee for Standardization, 2013.
4. Katz, A., Properties of concrete made with recycled aggregate from partially hydrated old concrete, Cement and Concrete Research, 2003, 33, pp. 703-7011.
5. Evangelista, L. and De Brito, J., Durability performance of concrete made with fine recycled concrete aggregates, Cement and Concrete Composites, 2010, 32, pp. 9-14.
6. Evangelista, L. and De Brito, J., Mechanical behaviour of concrete made with fine recycled concrete aggregates, Cement and Concrete Composites, 2007, 29, pp. 397-401.
7. Debieb, F. Kenai, S. The use of coarse and fine crushed bricks as aggregate in concrete. Construction and Building Materials, 2008, 22, 886-893.
8. Khatib, J.M. Properties of concrete incorporating fine recycled aggregate. Cement and Concrete Research, 2005, 35(4), 763-769.
9. Torrent R.J., A two-chamber vacuum cell for measuring the coefficient of permeability to air of the concrete cover on site, Materials and Structures, 1992, 25, pp. 359-365.



## Expanding Boundaries: Systems Thinking for the Built Environment

### THE COST AND ENVIRONMENTAL IMPACT OF SERVICE LIFE EXTENDING SELF-HEALING ENGINEERED MATERIALS FOR SUSTAINABLE STEEL REINFORCED CONCRETE

P. Van den Heede<sup>1,2\*</sup>, B. Van Belleghem<sup>1,2</sup>, N. De Belie<sup>1</sup>

<sup>1</sup> Magnel Laboratory for Concrete Research, Ghent University, Technologiepark  
Zwijnaarde 904, B-9052 Ghent, Belgium

<sup>2</sup> Strategic Initiative Materials (SIM), project ISHECO within the program "SHE", SIM  
vzw, Technologiepark Zwijnaarde 935, B-9052 Ghent, Belgium

\*Corresponding author; e-mail: philip.vandenheede@ugent.be

#### Abstract

To achieve higher sustainability of steel reinforced concrete structures, their service life should be extended. When subject to chloride induced steel corrosion, time dependent repair works are most probably inevitable. Evidently, this results in extra concrete manufacturing and thus more environmental impact. Cracks offering direct pathways for the corrosion inducing substances play a very detrimental role in this. This paper presents the potential of using self-healing concrete to cope with this problem. By incorporating a polyurethane (PU)-based healing agent that is adequately released upon crack occurrence, chloride ingress is hindered substantially and onset of active corrosion is postponed. The required number of repair actions within 100 years could then drop to zero. Nevertheless, the implementation of a self-healing mechanism comes along with a higher initial cost and additional environmental impacts. Therefore, the necessary cost and life cycle assessment calculations have been performed as well. It was found that the cost of the PU-based healing agent is very reasonable while the extra costs of the capsules are for the moment still unacceptable. Environmental burdens associated with the PU precursor filled capsules are negligible (0.1–4.8%) in comparison with the impacts related to regular concrete repair to meet the design service life of 100 years.

#### Keywords:

Self-healing concrete; service life extension; cost analysis; life cycle assessment

## 1 INTRODUCTION

The potential service life performance of a steel reinforced concrete structure highly determines its sustainability. This is easy to understand because a high susceptibility to, for instance, chloride induced corrosion of embedded reinforcing steel automatically implies regular repair actions in the course of time to maintain the integrity of the structure during its design service life [1]. Traditional concrete structures are almost never free of cracks and unfortunately, they serve as preferential pathways for chlorides. In previous research, it was shown by means of probabilistic service life prediction (cf. Visser et al. [2]) based on chloride diffusion tests at various exposure times and an assumed concrete cover of 50 mm, that the presence of cracks, 0.3 mm wide and 25

mm deep, reduces the time to chloride-induced steel depassivation from 104 to barely 8 years [3]. Therefore, it is certainly worthwhile to explore any possible strategy to cope with concrete cracking. One very promising strategy consists of implementing autonomous healing mechanisms in the concrete that are activated upon crack occurrence. Over the years, quite some research has been performed at the Magnel Laboratory for Concrete Research on the effectiveness of incorporating encapsulated PU precursors to achieve this self-healing. It resulted in a full proof of principle [4, 5]. A next important research phase consists in showing with how many years the service life of corrosion exposed steel reinforced concrete can indeed be extended and whether this can be done at an acceptable cost and without

substantial environmental burden. The service life issue has already been dealt with in Van den Heede et al. [3]. This paper mainly focuses on the economic and environmental aspects involved. It should be noted that only the material costs and impacts were considered in this study.

## 2 MATERIALS AND METHODS

### 2.1 Concrete mixture and slab

The studied concrete mixture is the same one that was used in Van den Heede et al. [3]. It is suitable for use in exposure class XS2 which corresponds with environments where concrete is permanently submerged in seawater. It meets the k-value concept of NBN B15-001. Per m<sup>3</sup> of this concrete, this gives a CEM I 52.5 N content of 317.6 kg and a fly ash content of 56 kg for the binder fraction. A water content of 153 kg was assumed to achieve the required water-to-binder (W/B) ratio of 0.41. To ensure a sufficient workability (slump class S3) a polycarboxylic ether-based superplasticizer (SP) was added (dosage: 3.0 ml/kg binder). Regarding its inert fraction per m<sup>3</sup>, the concrete contained 696 kg river sand 0/4, 502 kg gravel 2/8 and 654 kg gravel 8/16. This composition with strength class C40/50 and ribbed steel bars with a diameter of 16 mm and steel quality 500 were used to design a slab (span: 5 m, width: 1 m) with a variable load of 5 kN/m<sup>2</sup>. Design calculations done in accordance with Eurocode 2 showed that the slab thickness and required number rebars would need to amount to 0.17 m and 6, respectively.

### 2.2 Self-healing mechanism

The concrete can be given self-healing properties by incorporating cylindrical borosilicate glass capsules (inner diameter: 3.00 mm, outer diameter: 3.35 mm, length: 35 mm) filled with a one component PU precursor cf. Van Tittelboom et al. [5]. They are characterized by a high brittleness. As such, they break easily upon crack occurrence. A major drawback of these capsules is that they do not easily survive the concrete mixing process. PMMA-based alternatives for these capsules with a time-varying brittleness are for the moment still under investigation.

The healing agent was a non-commercial PU precursor which was developed within the framework of SHEcon, another research project on self-healing concrete [6]. The polymer can be compared with a typical flexible PU foam of which the precursor essentially consists of methylene diphenyl diisocyanate (MDI) and a polyether polyol. This precursor reacts with water to create the foam that heals the cracks. The moisture content of the concrete itself counts as the main water source.

Regarding a possibly recommended dosage for this encapsulated PU precursor, Van Belleghem et al. [7] incorporated three capsules with a 20 mm spacing to heal an artificially induced crack, 0.3

mm wide, 25 mm deep and 60 mm long. With the potential number of cracks and their location known, a more precise dosage could be defined. Two possible scenarios were considered in this theoretical case study.

Firstly, it was assumed that capsules were placed only in the zone where tensile stresses and thus cracks are to be expected. In case of a concrete slab (length: 5 m, width: 1 m, thickness: 0.17 m), capsules could then for instance be placed only near the bottom side of the mold (12.5 mm from the mold surface) prior to concrete casting. To be able to heal 0.3 mm wide and 25 mm deep cracks over the entire 5 × 1 m<sup>2</sup> bottom surface of the slab, 4150 capsules filled with PU-based healing agent would be needed in that zone.

Secondly, as cracks in the tensile zone of a slab usually have a depth higher than 25 mm, extending beyond the location of the rebars, the encapsulated PU-based healing agent should maybe be treated as bulk addition to concrete. When added in sufficient quantities during concrete mixing, the capsules would be well distributed over the entire slab volume. In that case the original number of capsules needs to be multiplied by 7 to have 4150 capsules in each ± 25 mm layer of the 170 mm thick slab. This gives 29050 capsules in total for the second scenario.

It should be noted that the two scenarios considered still require further investigation and optimization regarding their practical feasibility. Further experimental research on easy-to-use techniques for incorporating encapsulated PU precursors in prefabricated concrete elements is for the moment still ongoing at our laboratory.

### 2.3 Cost of the slab components

Based on the prices of all its constituents, the concrete would cost around 65 €/m<sup>3</sup>. A Belgian metal work supplier sells the applied rebars at a price of a little less than 1 €/m. The price of the borosilicate glass capsules equals 0.3 €/capsule, while the amount of PU precursor needed to fill one capsule would only cost 0.0005 €. The cost of time-dependent rehabilitation actions of traditional concrete without self-healing properties was taken into account by including the cost of the required concrete repair volume within a 100 year timespan, again at a price rate of 65 €/m<sup>3</sup>. Within Section 3.2, the absence of repair actions for self-healing concrete will be substantiated further on with results of previously conducted service life calculations.

### 2.4 Life cycle assessment

Cf. ISO 14040, the LCA consisted of four major steps: definition of goal and scope, inventory analysis, impact analysis and interpretation.

#### *Definition of Goal and Scope*

This LCA was conducted to quantify the reduction in environmental impact that could be achieved by using the proposed PU-based self-healing

concrete instead of a traditional concrete in a submerged marine environment. To do this correctly, the LCA study takes into account the difference in service life between traditional (cracked) concrete and the same concrete with self-healing properties. Therefore, a reinforced concrete slab with a variable load of 5 kN/m<sup>2</sup> and a design service life of 100 years was chosen as functional unit (FU). As such, the extra material needed to repair the slab as soon as steel corrosion is at risk was considered. For a slab repair, an extra concrete volume representing the 50 mm cover on top of the rebars plus the thickness of these rebars was taken into account.

**Inventory Analysis.** Per concrete constituent, the life cycle inventory (LCI) data was collected from the Ecoinvent database [8] (Table 1).

Constituent	LCI description Ecoinvent
Sand	Sand, at mine/CH U
Gravel 2/8 & 8/16	Gravel, round, at mine/CH U
CEM I 52.5 N	Portland cement, strength class Z 52.5, at plant/CH U
Fly ash	partially contains: 'Electricity, hard coal, at power plant/BE U', through economic allocation
Water	Tap water, at user/CH U
Glass capsule	Glass tube, borosilicate, at plant/DE U
PU-based healing agent	Polyurethane, flexible foam, at plant/RER U (modified)

Table 1: Overview of the Ecoinvent life cycle inventory (LCI) data used.

For the allocation of impacts related to the industrial by-product fly ash, the economic allocation coefficient as proposed by Chen et al. [9] was applied. This is 1.0% of the impact of the coal fired electricity production corresponding with the production of 1 kg fly ash. SP inventory data were obtained from an environmental declaration published by the EFCA [10]. The transport of each constituent to the concrete plant was not incorporated in the LCA since its environmental impact is always very case specific. The impacts related with the production process at a concrete plant were included by the partial assignment of the following LCI from Ecoinvent: 'Concrete, normal at plant/CH U'. It comprises the whole process of producing 1 m<sup>3</sup> of ready-mixed concrete, including all internal processes (transport, wastewater treatment, etc.).

As indicated above, the existing LCI for PU flexible foam was somewhat modified to make it more representative for the PU that was used in this research. One important change relates to the fact that the toluene diisocyanate (TDI) needed to be replaced with methylene diphenyl diisocyanate (MDI). Another distinct modification was the

removal of the water for reaction with the PU precursor from the LCI, as this water is being provided by the moisture content of the concrete. The PMMA sealant that was used to close the glass tubes once filled was so small that this component could be omitted from the LCI.

#### Impact Analysis and Interpretation

The CML-IA impact method was used. It gives an eco-profile with ten baseline impact indicators regarding abiotic depletion (ADP, MJ fossil fuels), global warming (GWP, kg CO<sub>2</sub> eq), ozone depletion (ODP, kg CFC-11 eq), human toxicity (HTP, kg 1,4-DB eq), freshwater aquatic ecotoxicity (FAETP, kg 1,4-DB eq), marine aquatic ecotoxicity (MAETP, kg 1,4-DB eq), terrestrial ecotoxicity (TETP, kg 1,4-DB eq), photochemical ozone creation (POCP, kg C<sub>2</sub>H<sub>4</sub> eq), acidification (AP, kg SO<sub>2</sub> eq) and eutrophication (EP, kg PO<sub>4</sub> eq).

## 3 RESULTS AND DISCUSSION

### 3.1 Maintenance scenarios

Based on earlier conducted service life predictions for PU-based self-healing concrete and traditional (cracked) concrete [3], two different maintenance scenarios were considered (Table 2).

Scenario 1	Time-dependent repair of traditional (cracked) concrete
Estimated service life	8 years [3]
Time-dependent maintenance	Replacement of the concrete cover
Number of repairs within a 100 year timespan	12
Scenario 2	Repair-free PU-based self-healing concrete
Estimated service life	104 years [3]
Time-dependent maintenance	None
Number of repairs within a 100 year timespan	None

Table 2: Overview of the maintenance scenarios considered.

The earlier obtained service life performance for PU-based self-healing concrete in marine environments only applied to the option with incorporation of capsules in one layer [3]. The bulk addition approach is for the moment still under investigation. Although the estimated service life performance of the latter option probably differs from the first, the same service life of 104 years was taken into consideration for now.

### 3.2 Cost analysis

Given the unit prices of the different slab components (Section 2.3), the regular (cracked) steel reinforced concrete slab (span: 5 m, width: 1

m, thickness: 0.17 m) would cost around 85 €. Incorporation of one layer of 4150 PU filled capsules would add 1373 € to this price. When adding the capsules in bulk to ensure their presence over the entire concrete volume, no less than 9605 € extra would need to be spent. The major contributors in these high extra costs are the borosilicate glass capsules which are – as stated earlier – not really feasible from a practical point of view anyway. When only considering the extra costs inherent to the PU precursor, the extra costs are much more acceptable, especially when their presence would avoid slab repair within the lifespan it was designed for. Adding PU precursor in only one layer would cost only 2.1 € extra, while adding the PU precursor in bulk, would add 14.7 € to the price of the steel reinforced slab. Thus, in comparison with the price (= 21 €) of one concrete repair volume (= 0.32 m<sup>3</sup>), a slab with self-healing properties holds an economic benefit. Given the fact that in presence of 25 mm deep cracks the expected time to chloride-induced steel depassivation would only be 8 years [3], this benefit would even be much more pronounced because the concrete repair volume would need to be applied 12 times. This means that one would need to spend 253 € extra to guarantee the integrity of the concrete slab for 100 years. On the other hand, when using a concrete that can be considered free of 0.3 mm wide cracks, chloride-induced steel depassivation would take no less than 104 years [3] and the costly rehabilitation actions would not be necessary at all. Thus, once a sufficiently cheap and practically feasible type of capsule for the PU-based healing agent would become available and a 100% healing capacity can be assured as such, contractors would most probably be willing to pay the slightly higher, PU precursor attributed production cost of the self-healing concrete.

### 3.3 Life cycle assessment

As can be seen in Fig.1, the impacts associated with the required twelvefold repair for a traditional steel reinforced concrete slab within a 100 year timespan are substantial. For all ten baseline impact categories, the environmental burdens related to the concrete needed for all repair works are usually at least two times higher than the impact of the concrete and steel needed for the initial construction of the slab. On the other hand, the incorporation of 4150 PU filled capsules in one layer at the bottom of the slab to ensure

autonomous healing of 0.3 mm wide and 25 mm deep cracks, brings along very little extra environmental burden.

Depending on the category indicator, their impact contribution amounts to only 0.1–0.7% of the one of the required concrete volume for 12 repairs in the course of time. When adding 29050 PU precursor filled capsules over the entire slab volume, the impact only increases slightly to 1.0–4.8% of the concrete repair volume related impact. Still, this looks very acceptable. Thus, if a 100% autonomous healing efficiency could indeed be achieved with this encapsulated PU-based healing agent, ensuring a repair-free 100 year service life in exposure class XS2, the environmental benefits of self-healing concrete easily overcome the burdens of the PU precursor filled capsules. It indicates that this novel concrete type indeed has a high sustainability potential.

## 4 CONCLUSIONS

A cost analysis for PU-based self-healing concrete demonstrated that the extra costs related to the PU precursor alone are very acceptable. It would increase the overall price of the slab with only 2.1–14.7 €. This is much lower than the 253 € that would need to be spent on repair works within a time period of 100 years without self-healing mechanism present in a submerged marine environment. The price of the now applied borosilicate glass capsules is far more critical. Nevertheless, these are not the type of capsules that will be used eventually as they do not survive the mixing process. A feasibility study of alternative PMMA-based capsules with a time-varying brittleness is for the moment still ongoing.

In terms of environmental impact, the PU-based self-healing concrete is far more beneficial than ordinary (cracked) concrete when exposed to chloride-induced corrosion. For all ten CML baseline indicators the impact is less than half, both when the capsules are added in only one layer of the slab and when added in bulk. Without self-healing properties, a twelvefold repair is required within a time span of 100 years. The impacts related to the extra concrete manufacturing extensively exceed those of producing the required quantity of PU precursor filled glass capsules (up to 29050) to ensure self-healing.

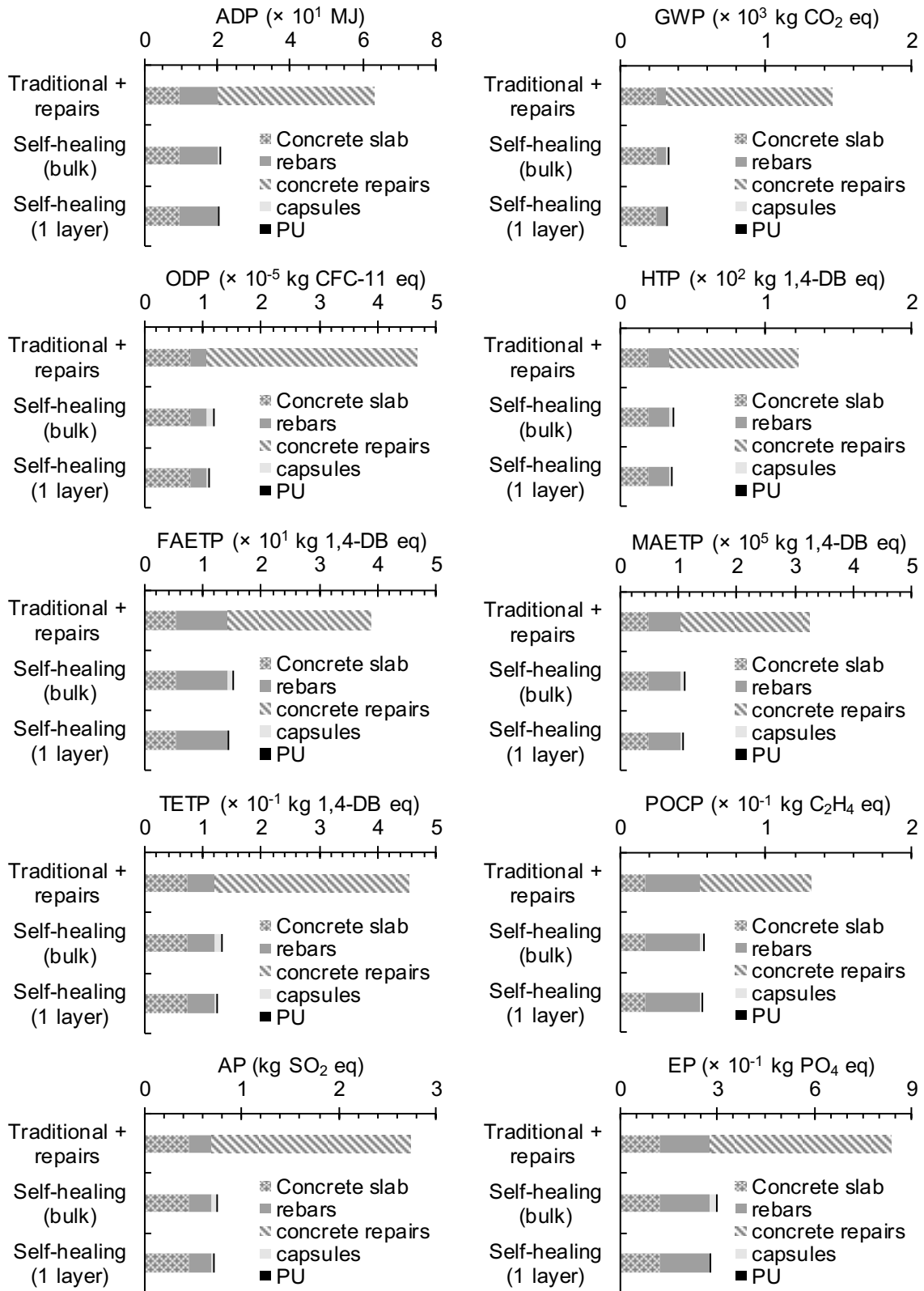

Fig. 1: Comparison in environmental impact (ADP, GWP, ODP, HTP, FAETP, MAETP, TETP, POCP, AP, EP) between traditional (cracked) and self-healing concrete slabs.

## 5 ACKNOWLEDGMENTS

This research under the program SHE (Engineered Self-Healing materials), project ISHECO (Impact of Self-Healing Engineered materials on steel COrrOsion of reinforced concrete) was funded by SIM (Strategic Initiative Materials in Flanders) and IWT (Agency for Innovation by Science and Technology). The financial support from the foundations for this study is gratefully acknowledged.

## 6 REFERENCES

1. Van den Heede, P., Durability and sustainability of concrete with high volumes of fly ash. PhD thesis. 2014, Ghent. Belgium: Ghent University.
2. Visser, J.H.M., et al., Time dependency of chloride diffusion coefficients in concrete, in Third international RILEM workshop on testing and modelling the chloride ingress into concrete. 2002: Madrid, Spain. p. 423-33.
3. Van den Heede, P., et al., Sustainability effects of including concrete cracking and healing in service life prediction for marine environments, in Fourth international conference on sustainable construction materials and technologies. 2016: Las Vegas, USA.
4. Van Tittelboom, K., Self-healing concrete through incorporation of encapsulated bacteria- or polymer based healing agents. PhD thesis. 2012, Ghent. Belgium: Ghent University.
5. Van Tittelboom, K., et al., Self-healing efficiency of cementitious materials containing tubular capsules filled with healing agent, *Cem. Concr. Compos.*, 2011. 33(4): p. 497-505.
6. Van Tittelboom, K., et al., Self-repair of thermal cracks in concrete sandwich panels, *Struct. Concr.*, 2015. 16(2): p. 273-88.
7. Van Belleghem, B., et al., Resistance to chloride penetration of self-healing concrete with encapsulated polyurethane, in fourth international conference on sustainable construction materials and technologies. 2016: Las Vegas, USA.
8. Frishknecht, R., and Jungbluth, N. (Eds.), Overview and methodology, in Final report ecoinvent v2.0 No. 1. 2007, Swiss Centre for Life Cycle Inventories: St.-Gallen.
9. Chen, C., et al., LCA allocation procedure used as an incitative method for waste recycling: An application to mineral additions in concrete, *Resour. Conserv. Recy.*, 2010. 54(12): p. 1231-40.
10. EFCA, EFCA Environmental Declaration Superplasticizing Admixtures (2006), <http://www.efca.info/publications.html>>(Dec. 9, 2015).





## Expanding Boundaries: Systems Thinking for the Built Environment

### ECO-MECHANICAL PERFORMANCES OF UHP-FRCC: MATERIAL VS. STRUCTURAL SCALE ANALYSIS

A.P. Fantilli<sup>1\*</sup>, S. Kwon<sup>2</sup>, H. Mihashi<sup>2</sup>, T. Nishiwaki<sup>2</sup>

<sup>1</sup> Politecnico di Torino, Corso Duca degli Abruzzi 24, Torino 10129, Italy

<sup>2</sup> Tohoku University, 6-6, Aoba, Aramaki, Aoba-ku, Sendai, Miyagi 980-8579, Japan

\*Corresponding author; e-mail: [alessandro.fantilli@polito.it](mailto:alessandro.fantilli@polito.it)

#### Abstract

One of the big challenges of the construction industry is to reduce the use of cement in new concrete structures for environmental purposes. Ultra-High Performance Fiber-Reinforced Cementitious Composites (UHP-FRCC) can reduce such impact, although the cement content per unit volume is higher than conventional concrete. Due to the high strength and high energy absorption capacity of UHP-FRCC, a reduction of the total amount of structural concrete, and consequently a reduction of cement, can be achieved. However, the results of the sustainability analysis depend on the scale of observation. For this reason, a more effective procedure to evaluate the eco-mechanical performance is herein introduced with the aim of tailoring eco-friendly cement-based composites. The proposed approach has been applied to some UHP-FRCCs containing wollastonite microfibers, which remarkably improve the mechanical performances at structural scale level, without increasing the environmental impact of the materials.

#### Keywords:

Ultra High-Performance Fibre-Reinforced Cementitious Composites (UHP-FRCC); Wollastonite microfibers; Eco-Mechanical Performances; Material scale analysis; Structural scale analysis.

#### 1 INTRODUCTION

According to Fantilli and Chiaia [1], the best concrete mixture must show the highest Eco-Mechanical Index (*EMI*), in which both the ecological and mechanical aspects are included:

$$EMI = MI/EI \quad (1)$$

where *MI* = mechanical index, and *EI* = ecological index.

To rate these performances in a more comprehensive way, also the non-dimensional diagram illustrated in Fig.1 can be used [2]. In this diagram,  $MI_{inf}$  is the lower bound value of the mechanical performances, whereas the upper bound value of the ecological impact is represented by  $EI_{sup}$ . Both these bounds can be prescribed by code rules, or imposed by tender requirements. Accordingly, four different zones can be detected within the non-dimensional diagram (see Fig.1):

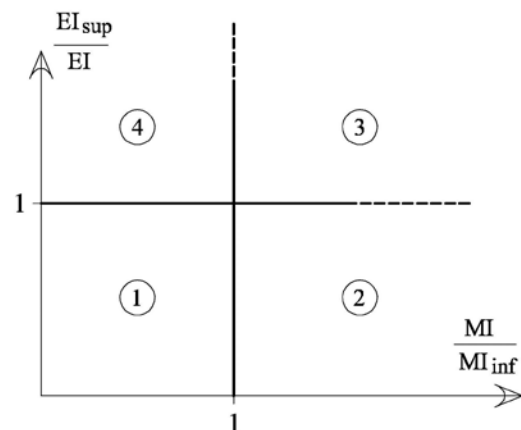

Fig. 1: The non-dimensional diagram to rate the eco-mechanical performances of cement-based composites.

- Zone 1: Low mechanical performances– Low ecological performances;

- Zone 2: High mechanical performances–Low ecological performances;
- Zone 3: High mechanical performances–High ecological performances;
- Zone 4: Low mechanical performances–High ecological performances.

The application of the Eco-mechanical analyses to Ultra-High Performance Fiber-Reinforced Cementitious Composites (UHP-FRCC), whose strength and ductility is higher than those of the conventional Fiber-Reinforced Cementitious Composites (FRCC) [3], can appear a pointless academic exercise. As is well known, the content of cement, and of the fibers as well, is remarkably higher, and therefore the environmental impact increases with respect to that of FRCC. Even with the partial substitution of the sand with wollastonite, a natural material capable of increasing the mechanical performances [4], UHP-FRCC cannot be considered as an environmental friendly concrete. This is particularly true when the performances are measured at the material scale [5]. Conversely, the following sections show the better ecological and mechanical performances of a full-scale structural member (i.e., the beam of a frame) made with UHP-FRCC containing wollastonite.

## 2 ANALYSIS AT MATERIAL SCALE

Four UHP-FRCCs are herein investigated. The mix proportions of these composites are shown in Table 1 (where, W = water, B = binder, SP = superplasticizer, D = anti-foaming agent, S = sand, and Wo = wollastonite microfibers). In all the series, 1.5 % of macrofiber (steel-B in Table 2) and 1.0 % of steel mesofibers (steel-A in Table 2) have been added. With respect to the reference composite named U\_0, in all the other UHP-FRCC the sand was partially replaced by wollastonite microfibers ( $\text{CaSiO}_3$ ) at volume content of 27%. The aspect ratios of the three wollastonite microfibers Wo-1, Wo-2, and Wo-3, added respectively to U\_1, U\_2 and U\_3, were almost the same (see Table 2). The Wo-1 fibers varied in length from 50 and 2,000  $\mu\text{m}$ .

Series	W/B wt %	SP/B wt %	D/B wt %	S/B wt %	Wo/B wt %
U_0	15	1.3	0.02	48	-
U_1		1.8		35	13
U_2					
U_3					

Table 1: The UHC-FRCC investigated in the present project.

In addition, Wo-1 varied more in length and diameter with respect to Wo-2 fibers and Wo-3 fibers (Table 2). The densities of the silica sand and of the wollastonite microfibers were 2.6  $\text{g/cm}^3$  and 2.9  $\text{g/cm}^3$ , respectively.

fiber	Length mm	$\Phi$ $\mu\text{m}$	$f_y$ MPa	$E_s$ GPa
Wo-1	0.05-2	-	2700-4100	303-530
Wo-2	0.6	40		
Wo-3	0.16	15		
steel-A	6	160	2000	205
steel-B	30	380	3003	

Table 2: Properties of the fibres.

### 2.1 Evaluation of EI

As the definition of  $EI$  is related to what is generally considered as pollution end/or environmental impact, the following formula is assumed herein:

$$EI = (\alpha \cdot wc_\alpha) \cdot (\beta \cdot wc_\beta) \cdot (\gamma \cdot wc_\gamma) \quad (2)$$

where  $\alpha$  = quantity of carbon dioxide ( $\text{CO}_2$ );  $\beta$  = quantity of embodied energy; and  $\gamma$  = volume of water. As the ecological performances are related to the local condition in the place of use [6], three weighting coefficients ( $wc_\alpha$ ,  $wc_\beta$ ,  $wc_\gamma$ ), which can be properly adjusted depending on water shortage, transportation, grabbing of raw materials, etc., are also introduced within Eq.(2). For instance, the longer the distance between concrete plant and building site, the higher the value of  $wc_\alpha$  due to the impact of transportation.

The impact of each component, in terms of  $\alpha$ ,  $\beta$ , and  $\gamma$ , is reported in Table 3. Such values are in accordance with those used by Chiaia et al. [7].

Components	$\alpha$ kg $\text{CO}_2$ /kg	$\beta$ MJ/kg	$\gamma$ m <sup>3</sup> H <sub>2</sub> O/kg
Cement type	0.832	4.73	1.64
Ground limestone	0.0191	0.755	1
Fly ash	-	-	-
Silica fume	-	-	-
Aggregates	0.00246	0.0546	0.027
Steel	1.50	20.6	2.79
Water	0.000318	0.0057	0.01
Wollastonite	0.0567	-	-
SP	0.72	18.3	-
Air entraining	0.086	2.1	-

Table 3: The ecological impact of concrete components [7].

For the sake of the simplicity, the three weighting coefficients  $wc_\alpha = wc_\beta = wc_\gamma = 1$ , and the impact of water is not considered (i.e.,  $\gamma=1$ ). Thus, Eq.(2) becomes:

$$EI = \alpha \cdot \beta \quad (3)$$

and the corresponding values of  $EI$ , referred to a cubic meter of the four series of concretes, are reported in Table 4.

Series	$EI$ kgCO <sub>2</sub> MJ/m <sup>3</sup>
U_0	1.33E+07
U_1	1.42E+07
U_2	1.42E+07
U_3	1.43E+07

Table 4: The ecological index of the cement-based composites.

## 2.2 Evaluation of MI

The mechanical performances of materials can be evaluated by considering the results of uniaxial tensile tests on dog bone samples (see Fig.2 [8]).

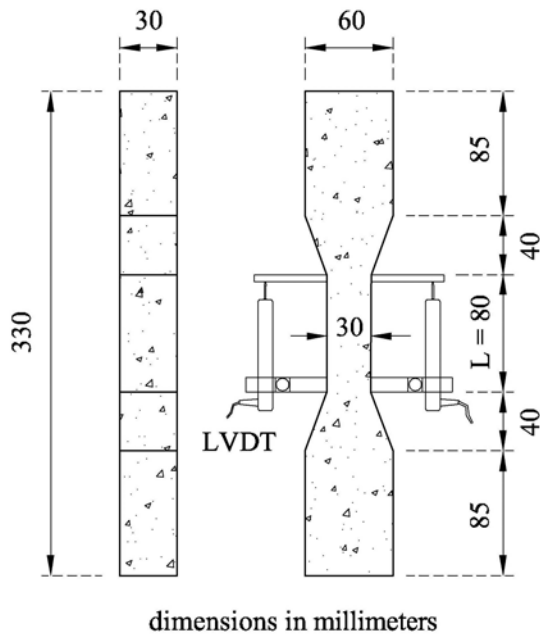

Fig. 2: Geometrical properties of the "dumbbell type" specimens under uniaxial tension [8].

The typical stress–strain relationship for UHP-FRCC under uniaxial tension is illustrated in Fig.3. In this figure, the symbol  $\sigma_{fcs}$  represents the crack initiation stress, at which the first crack occurs, and  $\sigma_{ts}$  represents the tensile strength. The average values of both the stresses, measured in the four series of concretes are reported in Table 5. In the same Table also the strain ( $\epsilon_{ts}$ ) at the tensile strength, generally considered as the strain capacity, is shown. In particular, it is the sum of the crack initiation strain ( $\epsilon_{fcs}$ ), and the inelastic strain up to the peak of stress. According to Naaman and Reinhardt [9], high-performance fiber-reinforced cement-based composites exhibit pseudo strain hardening with multiple cracks when  $\sigma_{ts} \geq \sigma_{fcs}$  (see Fig.3).

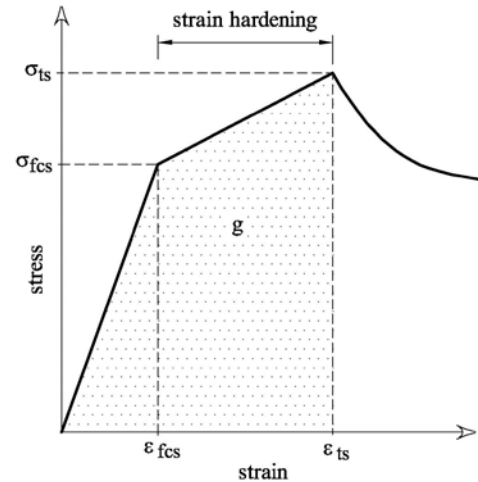

Fig. 3: Strain hardening with multiple cracking in UHP-FRCC.

During the strain-hardening stage the energy absorption capacity ( $g$ ) is defined as the area under the stress–strain curve from zero to  $\epsilon_{ts}$  (Fig.3). In UHP-FRCC the compressive strength is generally higher than 150 MPa and, in the pre-softening stage, the energy absorption capacity  $g$  is larger than 50 kJ/m<sup>3</sup> [3]. According to this definition, only U\_0 cannot be considered as UHP-FRCC, as the absorption capacity is half of the lower bound value.

Depending on the application of the UHP-FRCC, one of the four parameters reported in Table 5 is assumed to be the mechanical index  $MI$ .

Series	$\sigma_{fcs}$ MPa	$\sigma_{ts}$ MPa	$\epsilon_{ts}$ %	$g$ kJ/m <sup>3</sup>
U_0	9.5	10.6	0.11	26
U_1	12.5	14.6	0.74	112
U_2	13.5	16.1	0.93	146
U_3	13.8	16.2	1.16	156

Table 5: Some of the mechanical parameters of the cement-based composites herein investigated.

## 2.3 Eco-mechanical analyses

If  $EI_{sup}$  and  $MI_{inf1} = \sigma_{ts}$  are those of the control series U\_0 (see Table 4 and Table 5), the non-dimensional diagram shown in Fig.4a is obtained.

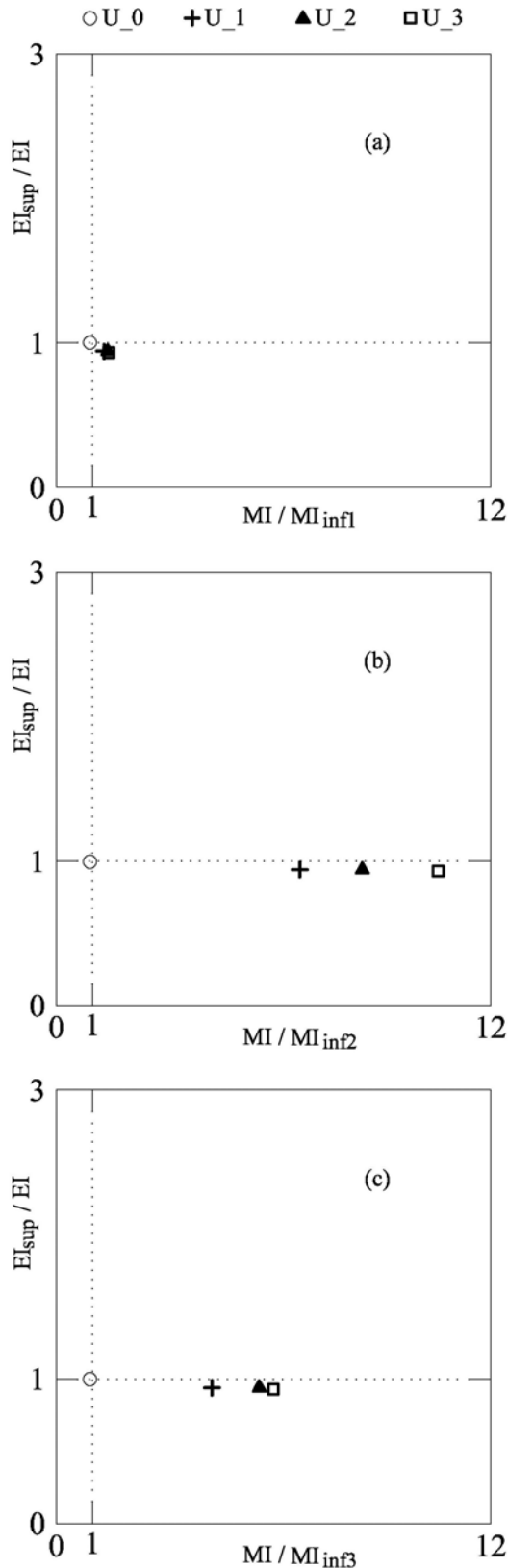

Fig. 4: The non-dimensional diagrams referred to the mechanical properties of U\_0: (a)  $MI_{inf1} = \sigma_{ts}$ ; (b)  $MI_{inf2} = \epsilon_{ts}$ ; (c)  $MI_{inf3} = g$ .

The analysis, performed at the material level (i.e., referred to a unit volume of U\_0), does not reveal a great difference of  $EI$  and  $MI$  among the investigated composites (see Table 4 and the

second column of Table 5). Whereas, a greater difference of the mechanical parameter can be observed when the other parameters reported in Table 5 are considered as  $MI$ . In fact, Fig.4b and Fig.4c show the comparisons in the case of  $MI_{inf2} = \epsilon_{ts}$ , and  $MI_{inf3} = g$ , respectively. Unfortunately, none of the UHP-FRCCs fall within zone 3 (Fig.1). Thus, a better comparison, especially in term of environmental impact, can be performed referring to a specific structure.

### 3 ANALYSIS AT STRUCTURAL SCALE

A simply supported concrete beam, having rectangular cross-section  $b \times h$ , and subjected to a bending moment  $M$ , can be considered. The behaviour of the materials can be reproduced by the stress-strain constitutive relationship depicted in Fig.5. In addition to the bilinear response in tension (Fig.3), the linear response in compression is also assumed ( $\sigma_{pc}$  = compressive strength, and  $\epsilon_{pc}$  = strain at  $\sigma_{pc}$ ). To define this relationship in the four series, the data reported in Table 5 and Table 6 are both considered. With these properties, a cross-section of  $b = 300$  mm and  $h = 500$  mm, and made with the control material U\_0, can resist to a bending moment of  $M = 230$  kN m.

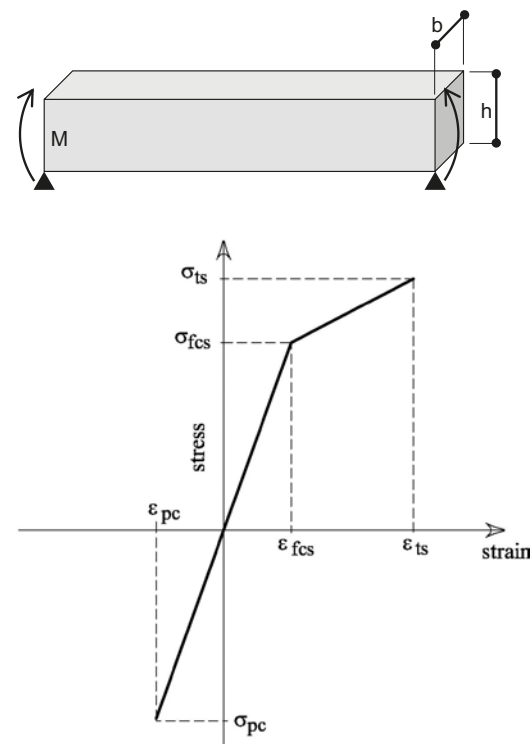

Fig. 5: The complete stress-strain relationship of a beam made with UHP-FRCC.

Series	$\epsilon_{fcs}$ %	$\sigma_{pc}$ MPa	$E_c$ GPa	$\epsilon_{pc}$ %
U_0	0.059	-211	510	-0.41
U_1	0.069	-181	484	-0.37
U_2	0.065	-187	490	-0.38
U_3	0.077	-202	502	-0.40

Table 6: The main mechanical parameters of the cement-based composites herein investigated.

If  $h = 500$  mm is constant, different values of  $b$  can be obtained when the cross-sections have the same moment capacity (i.e., 230 kN) but are made with the concretes of the other series. Table 7 reports the values of  $b$  and  $h$  of all the cross-sections, whereas the corresponding moment-curvature relationships are illustrated in Fig.6.

Series	$b$ mm	$h$ mm	$EI$ kgCO <sub>2</sub> MJ/m
U_0	300	500	1.99 E+06
U_1	161		1.14 E+06
U_2	144		1.02 E+06
U_3	140		1.00 E+06

Table 7: The geometrical dimensions of the cross-sections with a bending capacity of 230 kN m.

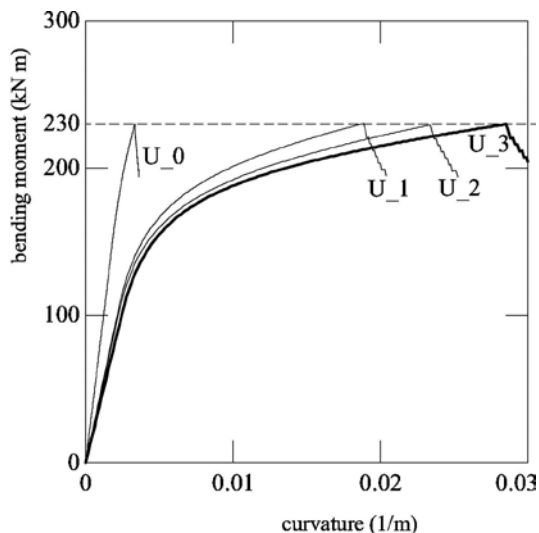

Fig. 6: The moment-curvature relationship obtained in the four series of concrete analyzed herein.

As shown in Fig.7a, all these diagrams can be approximated by a bi-linear relationship, in which the plastic part is limited by the maximum bending moment (i.e.,  $M = 230$  kN m). Moreover, each bilinear diagram must define the same area with respect to the curvature axis. Accordingly, the first part of the bilinear moment-curvature can be calculated in order to have the area  $A_1 = A_2$ ,

as reported in Fig.7a. In the new bilinear diagrams, the larger the curvature in the plastic stage (i.e.,  $\Delta\mu$ ), the larger the ductility capacity of the cross-section.

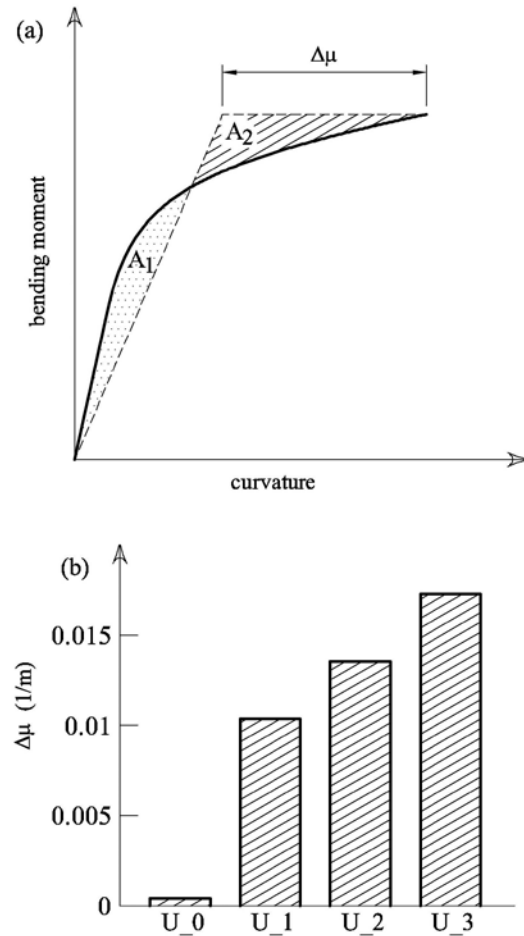

Fig. 7: The ductility of the cross-sections: (a) bi-linearization of the moment-curvature relationship; (b) evaluation of ductility  $\Delta\mu$ .

This is a fundamental mechanical property, especially for structures built in seismic areas. The values of  $\Delta\mu$  reported in Fig.7b can be considered the mechanical index of each beam.

With respect to the control cross-section made with U\_0, the use of wollastonite microfibers reduces the dimension and increases the ductility of the cross-section, without modifying the ultimate bending moment (see Table 7 and Fig.7b).

### 3.1 The eco-mechanical performances of beams

Thus, in concrete beams  $Ml = \Delta\mu$  can be considered. Whereas, the values of  $EI$  are those already evaluated in Table 4 multiplied by the area of each cross-section. In this way,  $EI$  is no longer related to the unit volume of the material, but to the unit length of the beam. Table 7 collects the new values of  $EI$ .

If  $EI_{sup}$  and  $Ml_{inf4} = \Delta\mu$  are those of the control cross-section U\_0, the new eco-mechanical

analysis can be performed, as reported in the non-dimensional diagram of Fig.8.

Although all the UHP-FRCCs fall within zone 3, the best performances are those of the series U\_3, because such concrete shows the best ecological (i.e., the lowest  $EI$  in Table 7) and mechanical (i.e., the highest  $MI$  in Fig.7b) performances when it is used in beams subjected to bending moment. Conversely, at the material level (see Table 4), U\_3 has the highest  $EI$ , or the highest environmental impact.

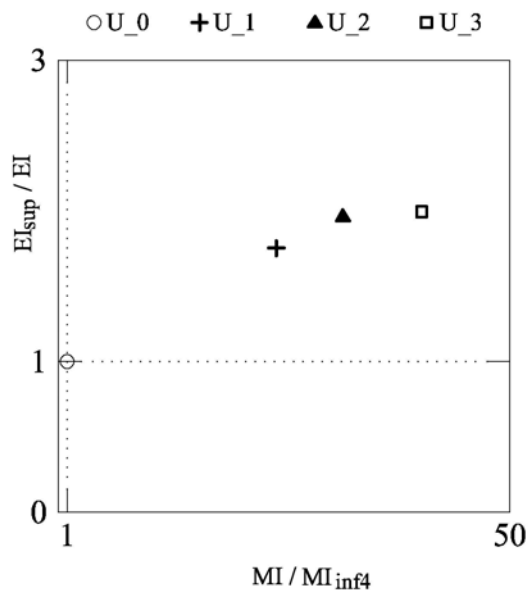

Fig. 8: The non-dimensional diagram referred to the mechanical properties of the beam U\_0 and to  $MI_{inf4} = \Delta\mu$ .

#### 4 SUMMARY

According to the results of both the theoretical and experimental analyses previously described, the following conclusions can be drawn:

- Both the ecological and mechanical performances have been measured conjunctly at material and structural scales.
- If only the mechanical properties of materials are taken into account, UHP-FRCCs made with wollastonite microfibers behave better than FRCC only in terms of mechanical performances.
- If the structural behaviour (i.e., strength and ductility) of a beam in bending are taken into account, UHP-FRCCs containing wollastonite microfibers behave better than FRCC.

As a general conclusion, the presence of wollastonite makes the UHP-FRCC more ductile and sustainable, thus a large use of this material in the concrete structures is desirable.

#### 5 REFERENCES

1. Fantilli, A.P. and Chiaia B. Eco-mechanical performances of cement-based materials: an application to self-consolidating concrete. *Construction & Building Materials*, 2013. 40: pp. 189–196.
2. Fantilli, A.P. and Chiaia, B. The work of fracture in the eco-mechanical performances of structural concrete. *Journal of Advanced Concrete Technology*, 2013. 11: pp. 282-290.
3. Wille, K., El-Tawil, S. and Naaman, A.E. Properties of strain hardening ultra high performance fiber reinforced concrete (UHP-FRC) under direct tensile loading. *Cement & Concrete Composites*, 2014. 48: pp. 53–66.
4. Kwon, S., Nishiwaki, T., Choi, H. and Mihashi, H. Effect of Wollastonite Microfiber on Ultra-High-Performance Fiber-Reinforced Cement-Based Composites Based on Application of Multi-Scale Fiber-Reinforcement System. *Journal of Advanced Concrete Technology*, 2015. 13 (7): pp. 332-344.
5. Habert, G. and Roussel, N. Study of two concrete mix-design strategies to reach carbon mitigation objectives. *Cement and Concrete Composites*, 2009. 31: pp. 397–402.
6. *fib*. Guidelines for Green Concrete Structures, in *fib* bulletin N. 67, 2012. International Federation for Structural Concrete: Lausanne.
7. Chiaia, B., Fantilli, A.P., Guerini, A., Volpatti, G. and Zampini D. Eco-mechanical index for structural concrete. *Construction and Building Materials*, 2014. 67 (Part C, 30): pp. 386-392.
8. Japan Society of Civil Engineers. Recommendations for Design and Construction of HPRCC with Multiple Fine Cracks, 2008. ([http://www.jsce.or.jp/committee/concrete/e/hpfrcc\\_JSCE.pdf](http://www.jsce.or.jp/committee/concrete/e/hpfrcc_JSCE.pdf)).
9. Naaman, A. E. and Reinhardt, H. W. Characterization of high performance fiber reinforced cement composites-HPFRCC, in 'High Performance Fiber Reinforced Cement Composites 2.1995: Ann Arbor, pp. 1-24

Zurich, June 15-17 2016

Sustainable Built Environment (SBE) Regional Conference

## Expanding Boundaries: Systems Thinking for the Built Environment



### LOW CARBON CEMENT: A SUSTAINABLE WAY TO MEET GROWING DEMAND IN CUBA

S. Sanchez<sup>1\*</sup>, Y. Cancio<sup>1</sup>, F. Martirena<sup>2</sup>, I.R. Sanchez<sup>1</sup>, K. Scrivener<sup>3</sup>, G. Habert<sup>4</sup>

<sup>1</sup> Faculty of Economy, Central University "Marta Abreu" of Las Villas (UCLV), Carretera a Camajuaní km 5, Santa Clara, Villa Clara, Cuba

<sup>2</sup> Center for Research and Development of Structures and Materials (CIDem), UCLV, Carretera a Camajuaní km 5, Santa Clara, Villa Clara, Cuba

<sup>3</sup> Laboratory of Construction Materials, Ecole Polytechnique Fédérale de Lausanne, CH-1015 Switzerland

<sup>4</sup> Chair of sustainable construction, ETH Zurich, CH-8093 Switzerland

\*Corresponding author; e-mail: [ssanchez@uclv.edu.cu](mailto:ssanchez@uclv.edu.cu)

#### Abstract

Concrete is, after water, the most used material worldwide and its demand is projected to growth in the next 30 years. Among all concrete materials, cement presents the higher energy consumption and carbon emissions, that's why this industry has been developing several alternatives to gain sustainability. The reduction of the clinker ratio by using Supplementary Cementitious Materials (SCM) allows a better use of existing capacities with low investment while a reduction in emissions, costs and energy per ton of cement is observed. The objective of this article is to assess the environmental and economic impact of a new cement with 50% of clinker: Low carbon cement (LC<sup>3</sup>). A procedure for evaluating sustainable and economic contributions of LC<sup>3</sup>, while projected demand is satisfied, is designed and applied in several scenarios. The results demonstrate that the introduction of LC<sup>3</sup> is the best option to meet growing demand considering capital investment options in non-developed countries conditions with a reduction of ~30% in carbon emissions, of ~10% in costs and a faster return of investments related to OPC figures in Cuba.

#### Keywords:

Low Carbon Cement; cement demand; economic and environmental assessment

### 1 INTRODUCTION

Cement is a key resource for economic progress and development. Consequently, global demand for cement and concrete has increased exponentially in the last twenty years as well as its related environmental impact. Due to this situation, the cement industry has applied several strategies to improve its production efficiency and to reduce both resources consumption and carbon emissions. One of the most effective solutions is the use of supplementary cementitious materials (SCM) [1-2].

Low Carbon Cement (LC<sup>3</sup>) has emerged as new alternative cement as a result of an international joint project funded by the Swiss Agency for Development and Cooperation with the

participation of scientists from Switzerland, Cuba and India. In LC<sup>3</sup> cement, it is replaced by up to 50% of clinker in cement by using calcined clay and limestone.

The Cuban economy is currently experiencing large structural changes. The Cuban government has declared an expected – and needed – annual Gross Domestic Product (GDP) growth from 3 to 5% [3]. To achieve this, the construction sector has to reach a level of production able to satisfy the development demands. In this paper, a method is designed and applied to assess the economic and environmental potential of the LC<sup>3</sup> cement technology in several scenarios of the Cuban context, while projected demand is satisfied.

## 2 DATA AND METHODS

### 2.1 Methodology

To assess the economic and environmental contribution of LC<sup>3</sup> production, the following methodologies are integrated and applied:

- (i) Forecast of cement demand
- (ii) Life cycle assessment (LCA)
- (iii) Capital expenditures (CAPEX) and Operational expenditures (OPEX) analysis

To forecast demand is a major issue in this study in order to estimate the investment needs to reach development. Demand for Cuba, cement demand was calculated using a model based on possible needs of cement according to social and economic infrastructure status and government plans for investments.

The environmental evaluation is done through a Life Cycle Assessment (LCA). It is a method for evaluating the environmental load of processes and products during their life cycle, from cradle to grave [4]. The LCA method is divided into 3 main stages [4]. First, the functional unit and the system boundaries have to be defined. Secondly, the inventory phase includes all inputs to outputs from the considered system. Finally, the environmental impact categories are defined and assessed. These three stages are detailed in the following section.

Capital and Operational Expenditures analysis are performed to assess and compare the economic impact of cements during their life cycle from investment process (CAPEX) until cement is produced. CAPEX were calculated based on literature and OPEX by using accounting norms established in Cuba. To a better understanding all costs were converted to US dollars.

### 2.2 Choice of the functional unit

This study focusses on the production and transport of the cement raw materials and ends at an intermediate stage after concluding the production process at the cement plant (cradle to gate). The functional unit used in the study is 1 ton of cement.

The study compares three cements production in Cuba:

- (1) The standard Ordinary Portland Cement (OPC). This cement in Cuba is made with 5% of Calcium Carbonate.
- (2) The current blended cement sold on the island (PPC). It is produced with 15% of Zeolite tuff considered as a Natural Pozzolan.
- (3) The new cement, called Limestone Calcined Clay cement (LC<sup>3</sup>) where 30% of Calcined Clay and 15% of Calcium Carbonate.

Previous studies provided confidence in the fact that similar compressive strength can be

achieved with these 3 cements [5] what was confirmed in the first industrial trial to produce LC<sup>3</sup> [6].

The production system under study has been separated into five main processes: (i) raw materials extraction; (ii) extraction and refinement of fuels; (iii) transport of raw materials and fuels; (iv) clinkerization and calcination of clays; and (v) grinding, packing and other processes. The final processes are gathered due to their low impact during the whole process of cement production [7].

The determination of same functional unit and system boundaries for economic and environmental assessment allows the integrated assessment after obtaining separately results.

### 2.3 Data collection

In this study the data is organized according to the technological level to be implemented reflecting a gradation in the investment.

- (i) The first level (Pilot) considers no investment. The data used for energy and material consumption were measured during the first industrial trial [6]. The clinkerization as well as the clay calcination were carried out at existing facilities within an inefficient and non-optimized production processes (wet process).
- (ii) The second technological level considers a low investment throughout retrofitting a wet cement kiln into a clay calciner, as a low CAPEX alternative to produce calcined clay. The clinker employed is produced by a more efficient technology (dry process).
- (iii) The third technological level considers massive investment in Best Available Technology (BAT), with state of the art equipment for both the calcined clay and the clinker production. Clay would then be calcined through a flash calciner and clinker would be produced by a dry process with pre heater and pre calciner.

Once these technological packages were established, the necessary data was collected. Data for emission factors and heating values of different types of fuels comes from different sources: (i) the Cement Sustainability Initiative (CSI) of the World Business Council for Sustainable Development [8] and (ii) the Intergovernmental Panel for Climate Change (IPCC) [9]. Some processes linked to the extraction of raw material and fuels, transport and electricity were modelled using the Ecoinvent database [10] and adapted when necessary to the Cuban conditions. The electricity mix, the fuel used for trucks and trains and lifetime of the current stock of Cuban transport infrastructure were adapted.



Preliminary data was collected from the Siguaney factory which has been selected by the Cuban Cement industry to introduce LC<sup>3</sup> production. The main data is related to consumption indexes, distances to raw materials, technology type, transport means and extraction processes.

To analyse CAPEX figures, data related with different investment scenarios was collected. The data is shown in Figure 1, where a simple comparison allows to prove the advantages of retrofitting over investing in a flash calciner.

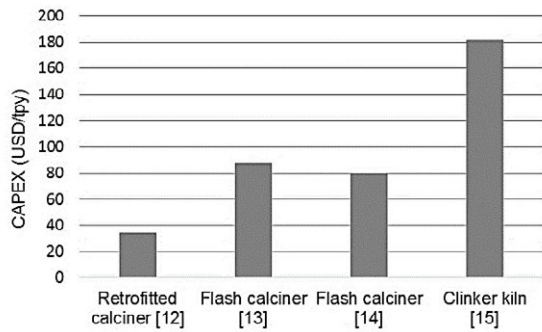

Fig. 1: CAPEX (US dollars per ton of cement per year) and references.

## 2.4 Impact assessment

In this study, only one impact category is shown: Global Warming Potential for one-hundred-year period of time projection (GWP100) expressed in kg CO<sub>2</sub> equivalent. It was calculated by the IPCC 2013 methodology [9]. This reduction is justified by the fact that CO<sub>2</sub> emission is the main impact of concrete industry and it is difficult to look for the large number of background and foreground data required for the other impact categories in Cuban statistics reports.

## 3 RESULTS

### 3.1 Demand forecast for Cuban case

Cuban cement industry reports production of 1.8million tons of cement in 2014 [15], this represents a 56% of utilization of the installed capacity. A higher utilization rate is not possible due to several periods of maintenance and reparation of equipment and facilities associated with the existing outdated technology. Then, a 68% of the available production capacity is determined. This proves the fact that present demand exceeds production and reflects the need for investment in this sector to increase manufacturing capacity.

Official government figures forecast cement demand of 3.5Mt/year by 2019. Demand

projection at peak demand phase (2016-2020) will grow 18% per year. This is linked to an expected booming construction activity that normally occurs in emerging economies. During the peak demand phase annual growth of 10% and 5% of demand are expected. Finally, authors estimate a capacity over 6.5 million tons/year to be reached in 2030.

### 3.2 Comparative Life cycle assessment of LC<sup>3</sup> and other products in Cuban case

#### Energy consumption

Results of a detailed analysis of the improvement potential of LC<sup>3</sup> production in relation to energy use show that the best improvement is observed in clinkerization and fuels extraction processes when compare with OPC production. An increase in energy consumption related to transport and raw materials extraction is also observed but this impact is clearly negligible when it is compared with savings achieved by the other processes. A reduction of ~20% in energy demand is achieved when compare with OPC, except using the BAT (which includes the use of renewable fuels) where 8% of energy is saved if LC<sup>3</sup> is produced. Table 1 presents the final results in energy analysis.

Cement	MJ/t	%
OPC	5292	100
PPC	4626	87
LC <sup>3</sup> _retrofitted	4158	79
LC <sup>3</sup> _flash	3692	70

Table 1: Energy consumption (MJ) per ton of cement produced.

#### Environmental impact (GHG emissions)

The comparison of the environmental impact for OPC, blended cement PPC and LC<sup>3</sup> for the three different technical levels: Pilot, Industrial and BAT– is shown in the figure 3. It is interesting to note that whatever the technological level, the LC<sup>3</sup> cement always produces around 30% savings of CO<sub>2</sub> eq emissions. Furthermore, it is noticed that the worse LC<sup>3</sup> cement made in the pilot industrial trial is better than the best OPC that can be produced with the BAT scenario. Major emission reductions are related to energy savings and clinker substitution, although there is reported a significant decrease in electricity consumption during grinding process due to LC<sup>3</sup> softness in comparison with OPC.

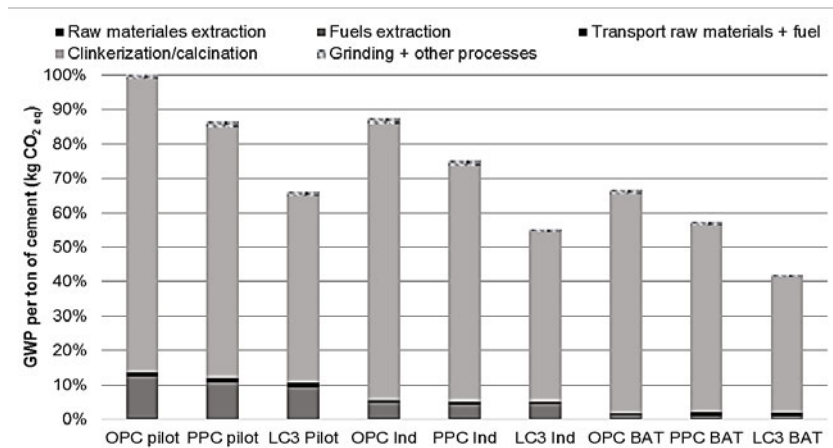

Figure 3. Relative Global Warming Potential impact of cement production in Cuba. All scenarios.

### 3.3 CAPEX and OPEX analysis

Operational expenditures were calculated in collaboration with an economic team of the Siguaney cement plant. Results confirm that with LC<sup>3</sup> production we can save 14-30% of costs in comparison with PPC and OPC respectively as shown in Figure 2.

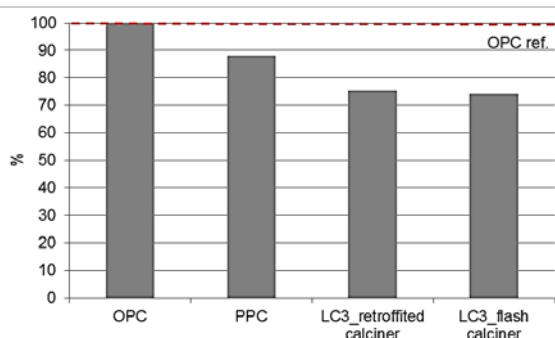

Figure 2. OPEX of cement production: comparison OPC and PPC vs. LC<sup>3</sup>.

Is notable that OPEX between flash and retrofitted are quite similar (flash is only 1% lower). This can be supported by 2 reasons: (i) CAPEX for flash is much higher; (ii) the other processes of cement production process are carried out in similar facilities, thus, costs for grinding, clinker production, packing, etc. are the same.

CAPEX figures show that the construction and installation of a clinker kiln (+ pre heater + pre calciner and cooling facilities) will always be more expensive than a clay calciner. Retrofitting is the best alternative thinking also in the lack of capital of non-developed countries like Cuba and the availability of old wet clinker kilns that can be retrofitted with low investment cost.

## 4 DISCUSSION

This assessment shows that promoting the use of LC<sup>3</sup> in Cuba is a long term efficient strategy from an environmental as well as from an economic point of view. Results show that LC<sup>3</sup> technology,

if implemented in Cuba will definitively provide an environmental advantage compared to the OPC and PPC produced on the island. The cost analysis shows also a smaller difference in comparison with PPC.

Finally, more detailed research needs to be done in the area of investment costs. The study shows the predominant contribution of investment costs (CAPEX) compared to operation costs (OPEX) in the production of cement from an economic and political point of view, but also from the availability of existing infrastructure. Then, the installation of a complete production line, will considerably increase the investment price for the LC<sup>3</sup> technology. Savings from an OPC modernization strategy will still be achieved but the difference will be smaller.

## 5 CONCLUSIONS

This study has assessed, from both an economic and environmental point of view, three cements that can be produced in Cuba. The study shows that the LC<sup>3</sup> technology, which involves the combination of 50% of clinker, 15% of unburned limestone and 30% of calcined clay (and 5% Gypsum), is an energy and cost efficient technology. Savings in term of greenhouse gases emissions as well as production and investment costs are significant.

The results presented have taken into account a number of variables and have shown to be robust. LC<sup>3</sup> has therefore a great potential to provide a viable opportunity to meet an increase in cement demand with low CO<sub>2</sub> released and low cost investment.

## 6 ACKNOWLEDGMENTS

Author would like to acknowledge to the Cuban cement industry, especially Siguaney plant and the Cuban Geological Survey for their collaboration in the process of data collection and costs calculation.

## 7 REFERENCES

1. OECD/IEA, WBSCD, 2009. Cement Roadmap.
2. Scrivener, K., 2014. Options for the future of cement. *Indian Concr. J.*
3. Murillo M. 2014. Speech about New Foreign Investment Law in the National Assambly. November, 10<sup>th</sup> 2014.
4. ISO 14040:2006 Environmental management -- Life cycle assessment -- Principles and framework, 2006.
5. Antoni, M., Rossen, J., Martirena, F., Scrivener, K., 2012. Cement substitution by a combination of metakaolin and limestone. *Cem. Concr. Res.* 42, 1579–1589.
6. Vizcaíno-Andrés, L.M., Sánchez-Berriel, S., Damas-Carrera, S., Pérez-Hernández, A., Scrivener, K.L., Martirena-Hernández, J.F., 2015. Impacto del uso de un cemento de bajo carbono en la mejora de la sostenibilidad de la producción de cemento. *Mater. Constr.* 65, e045. doi:10.3989/mc.2015.00614.
7. Chen, C., Habert, G., Bouzidi, Y., Jullien, A., 2010. Environmental impact of cement production: detail of the different processes and cement plant variability evaluation. *J. Clean. Prod.* 18, 478–485. doi:10.1016/j.jclepro.2009.12.014.
8. WBSCD Cement Sustainability Initiative, 2013. Getting the numbers right project- Reporting CO<sub>2</sub> 2013- Excel worksheet.
9. IPCC, 2015. Climate change 2014: synthesis report.
10. Frischknecht, R., Jungbluth, N., Althaus, H.J., Bauer, C., Doka, G., Dones, R., Hischier, R., Hellweg, S., Humbert, S., Köllner, T., 2007. Implementation of life cycle impact assessment methods. *Ecoinvent Rep.*
11. ECRA, 2009. ECRA\_\_Technical\_Report\_CCS\_Phase\_II [WWW Document]. URL [http://www.ecra-online.org/fileadmin/redaktion/files/pdf/ECRA\\_\\_Technical\\_Report\\_CCS\\_Phase\\_II.pdf](http://www.ecra-online.org/fileadmin/redaktion/files/pdf/ECRA__Technical_Report_CCS_Phase_II.pdf) (accessed 10.20.15).
12. San Nicolas, R., 2011. Performance-based approach for concrete containing metakaolin obtained by flash calcination (Theses). Université Paul Sabatier - Toulouse III.
13. FLSmidth, n.d. Personal communication.
14. Alsop, P.A., 2014. The Cement Plant Operations Handbook: For Dry-process Plants.
15. ONEI. (2014). Statistical Yearbook of Cuba 2013.



Zurich, June 15-17 2016  
Sustainable Built Environment (SBE) Regional Conference



## Expanding Boundaries: Systems Thinking for the Built Environment

### LIFE CYCLE ASSESSMENT OF PRECAST AND CAST-IN-SITU CONSTRUCTION

Y.H. Dong<sup>1</sup>, L. Jaillon<sup>2\*</sup>, C.-S. Poon<sup>3</sup>

<sup>1</sup> Faculty of Science and Technology, Technical and Higher Education Institute of Hong Kong, Hong Kong, China

<sup>2</sup> Department of Architecture and Civil Engineering, City University of Hong Kong, Kowloon, Hong Kong, China

<sup>3</sup> Department of Civil and Environmental Engineering, The Hong Kong Polytechnic University, Kowloon, Hong Kong, China

\*Corresponding author; e-mail: ljaillon@cityu.edu.hk

#### Abstract

Prefabrication is a sustainable construction method to provide better quality control, improved site safety and a reduction of the construction time and labour demand as compared with the traditional cast-in-situ construction. Hong Kong is a mega city with over 40,000 buildings and limited land area. The adoption of precast concrete in building constructions has become more and more frequent in both public and private sectors.

This study aims to compare the environmental impacts of precast and cast-in-situ construction methods through life cycle assessment. A typical private residential building project in Hong Kong is selected as both precast and cast-in-situ methods are used to construct the residential buildings. The comparison is carried out for the functional unit of a concrete façade element of the studied project. The scope of the study is to cover the processes from 'cradle to end of construction', including material extraction, manufacturing, transportation, and on-site construction.

It is found that the precast façade performs 6.3% better than the cast-in-situ façade in terms of the carbon emissions. The carbon emission for the precast façade is 647 kg CO<sub>2</sub> eq, while the figure is 708 kg CO<sub>2</sub> eq for the cast-in-situ façade. Based on the research findings, it is recommended to adopt precast concrete in building constructions. The industry should consider the carbon reduction as a benefit to implement precast concrete.

#### Keywords:

Carbon emissions; Hong Kong; Life cycle assessment; Precast concrete; Prefabrication

### 1 INTRODUCTION

Prefabrication is a process of manufacturing to assemble various materials to form a component part of the final installation at a specialized facility [1]. In Hong Kong, precast concrete has been adopted since the mid-1980s in public residential buildings developed by the Hong Kong Housing Authority (HKHA) [2]. Public and private housing both hold about half the population in Hong Kong. In recent years, precast concrete has been more and more frequently used in private residential

buildings, which is encouraged by the gross floor area (GFA) concession [3].

The adoption of precast concrete can largely reduce the on-site construction waste, time and labour, as well as improve the quality of construction [4]. As reported by previous studies, precast constructions can lead to a reduction of 52% of construction waste and 70% timber formwork [5]. The environmental benefits of precast constructions are also investigated by [6, 7]. While these studies only focused on the public sector, the environmental benefits of precast

concrete in the private sector have yet to be studied.

This research aims at comparing the environmental influence by adopting precast concrete in the private residential building sector. The precast façade element in a typical private residential building in Hong Kong is studied. Carbon emissions of precast façades and cast-in-situ façades are estimated using life cycle assessment (LCA). Project data is collected through questionnaire surveys and interviews. The analysis covers 'cradle-to-end of construction' life cycle stages. Suggestions to the construction industry are provided based on the research findings.

## 2 METHODS

The studied building is a high-rise residential building in Hong Kong to provide about 3,500 apartments. The buildings are 30-35 floors with eight apartments on one floor. A photo of the studied project is shown in Fig. 1. The project applies a precast façade that represent about 6% of the total concrete volume. In this study, a precast façade element in the studied project is compared with a hypothetical cast-in-situ façade element.



Fig. 1: The studied high-rise private residential building project (the photo is provided by developer).

The study system encompasses the 'cradle-to-end of construction' processes regarding a concrete façade element, including material extraction, transportation, manufacturing, and on-site construction. The functional unit for comparison is one concrete façade element.

The project data is collected through a questionnaire survey addressed to the precast manufacturer. The questionnaire is to collect the information about the energy and water consumption of the precast façade, as well as the waste generation within the precast yard. Another questionnaire for the on-site construction is delivered to the project manager for the information of construction waste, equipment use, energy consumption and waste generation

within the construction site. In addition, drawings and electricity bills are solicited from the contractor. Semi-structured interviews are conducted with project managers to further validate the collected data. To establish the LCA model, the Ecoinvent database is adopted to provide secondary data of upstream processes.

The precast yards to produce precast elements for the construction site in Hong Kong are located in Pearl River Delta in mainland China (outside Hong Kong). The transportation of precast elements is one of the key contributors to carbon emissions. The transportation details relevant to the studied building are given in Table 1. The details of the model inputs are given in Table 2. The electricity consumption to produce one precast façade at precast yard is 53 kWh, and the electricity consumption to install one precast façade on the construction site is 21 kWh. On the other hand, the electricity used for a cast-in-situ concrete façade on-site is 66 kWh. Lifting and installing façade elements consumes diesel, and it is estimated that one precast façade uses 12 L diesel, while one cast-in-situ uses 8 L diesel during manufacturing and on-site activities.

The LCA model is established in SimaPro 8. The model is composed of over one hundred project processes. Both the project data and secondary data from databases are used in the model. Since data from different regions are apparently different in terms of their value and quality [8], the model tried to incorporate the local information to offset this unavoidable discrepancy of LCA. The life cycle impact assessment (LCIA) method of Greenhouse Gas Protocol [9] is applied to calculate the carbon emissions of the two scenarios. The method was developed by the World Resources Institute (WRI) and the World Business Council on Sustainable Development (WBCSD) based on the global warming potential (GWP) factors proposed by IPCC.

Material	Country of origin	Distance	Transport method
Concrete mix	HKSAR	25 km	Concrete mixer
Cement	China	150 km	Truck 20-28 t
	China	150 km	Truck 20-28 t
Aggregate	China	150 km	Truck 20-28 t
	China	80 km	Truck 20-28 t
Precast concrete	China	150 km	Truck 20-28 t

Reinforcing steel	China	100 km	Truck 20-28 t
	China	250 km	Truck 20-28 t
Formwork steel	China	200 km	Truck 3.5-20 t
Formwork timber	China	250 km	Truck 20-28 t
Window glass	China	150 km	Truck 20-28 t

Table 1: Transportation details of the materials used in the high-rise residential building.

Item	Unit	Façade element	
		IS	PC
Cast-in-situ concrete	m <sup>3</sup>	0.92	0
Precast concrete	m <sup>3</sup>	0	0.92
Aluminium frame	m	12.5	12.5
Glass	kg	14.1	14.1
Tile	m <sup>2</sup>	4.47	4.45
Transport glass	tkm	2.12	2.12
Transport precast	tkm	0	381

Table 2: Model inputs for the cast-in-situ (IS) and precast (PC) scenarios.

### 3 RESULTS

The comparison for the façade elements is given in Fig. 2. The façade element includes the materials of concrete, steel, aluminium, tiles, glass, etc. The as-built precast façade element emits 941 kg CO<sub>2</sub> eq, while the hypothetical IS scenario emits 1,005 kg CO<sub>2</sub> eq, which is 6.3% higher than PC scenario. The carbon emissions of 0.92 m<sup>3</sup> concrete in PC and IS scenarios are 647 kg CO<sub>2</sub> eq and 708 kg CO<sub>2</sub> eq, respectively.

The difference is mainly due to the different formwork types used in the two different concrete methods. The cast-in-situ construction adopts timber formwork, which can only be reused less than 10 times. On the other hand, the formwork used to produce precast is steel that can be reused over 100 times. To cast 1 m<sup>3</sup> concrete, 45.7 kg timber formwork is required for cast-in-situ concrete, while 14.5 kg steel formwork is used for precast concrete. The carbon emission of timber formwork to produce the same amount of concrete is considerably higher than that of steel formwork.

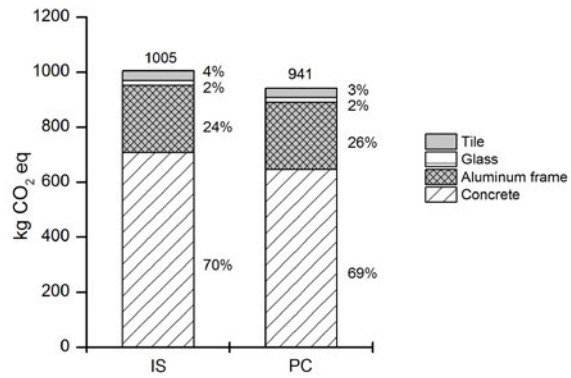

Fig. 2: Carbon emissions of concrete façade element (IS: cast-in-situ concrete; PC: precast concrete).

### 4 CONCLUSIONS

Carbon emissions of precast and cast-in-situ construction methods are compared using LCA. The model considers the "cradle-to-end of construction" life cycle stages. The results show that the carbon emission of precast concrete is apparently lower than that of cast-in-situ concrete. The as-built precast façade element emits 941 kg CO<sub>2</sub> eq, while the hypothetical IS scenario emits 1,005 kg CO<sub>2</sub> eq, which is 6.3% higher than the PC scenario. This is primarily due to the difference in formwork types. The timber formwork which can be reused only less than 10 times emits more greenhouse gases than steel formwork. Based on the research findings, it is highly recommended to adopt precast concrete to contribute to a more sustainable construction industry.

### 5 ACKNOWLEDGMENTS

The authors gratefully acknowledge the financial support of the City University of Hong Kong Strategic Research Grant #7002720. Thanks are due to the professionals of the building industry for their generous contributions and for providing valuable information for this study and giving access to construction sites and manufacturing plants. The authors wish to thank Mr. Tim Grant from Life Cycle Strategies in helping reviewing LCA works.

## 6 REFERENCES

1. CIRIA (1999) *Standardisation and Pre-assembly Adding Value to Construction Projects*, Report 176. Construction Industry Research and Information Association. 1999: London.
2. Mak, Y. *Prefabrication and industrialization of housing in Hong Kong*. The Hong Kong Polytechnic University. 1998: Hong Kong.
3. Buildings Department, *Joint Practice Note No. 2 Second Package of Incentives to Promote Green and Innovative Buildings*. 2011: The HKSARG, Hong Kong.
4. Jaillon, L. and C.-S. Poon, Sustainable construction aspects of using prefabrication in dense urban environment: a Hong Kong case study. *Constr Manage Econ*, 2008. 26: p. 953-966.
5. Jaillon, L. and C.-S. Poon, The evolution of prefabricated residential building systems in Hong Kong: A review of the public and the private sector. *Automat Constr*, 2009. 18: p.239-248.
6. Dong, Y.H. and S.T. Ng, A life cycle assessment model for evaluating the environmental impacts of building construction in Hong Kong. *Build Environ*, 2015. 89: p.183-191.
7. Wong, F. and Y. Tang, Comparative Embodied Carbon Analysis of the Prefabrication Elements compared with In-situ Elements in Residential Building Development of Hong Kong. *World Academy of Science*, 2012. 62: p.161-166.
8. Dong Y.H. and S.T. Ng, Substituting local data for overseas life cycle inventories—a case study of concrete products in Hong Kong. *J Clean Prod*, 2015. 87: p. 414-422.
9. GHGProtocol. 2014 [cited 2014 May 15]; Available from: <http://www.ghgprotocol.org/>





## Expanding Boundaries: Systems Thinking for the Built Environment

### PROCESS MAPPING AND PRELIMINARY ASSESSMENT OF LIFE CYCLE IMPACT IN INDIAN CEMENT PLANTS

R. Gettu<sup>1\*</sup>, S. Prakasan<sup>1</sup>, A. Patel<sup>1</sup>, V. Rathi<sup>2</sup>, K. Nagrath<sup>2</sup>, S. Palaniappan<sup>1</sup>, S. Maity<sup>2</sup>

<sup>1</sup>Indian Institute of Technology Madras, Chennai 600036, India

<sup>2</sup>Development Alternatives, B-32, TARA Crescent, New Delhi 110016, India

\*Corresponding author; e-mail: gettu@iitm.ac.in

#### Abstract

The Indian cement industry is the second largest in the world with an annual production of about 280 million tonnes. Though the environmental impact is significant, little has been done on process mapping, and associated accounting of the energy consumption and emissions in the cement plants. The salient features of cement production in India that distinguish it from other scenarios are highlighted. The present work proposes a framework and sets guidelines for the life cycle assessment. The computing of the energy requirement and CO<sub>2</sub> emissions is done for a typical cement plant considering ordinary portland cement (OPC) and fly ash based portland pozzolana cement (PPC). The values obtained indicate that the impacts could be much lower than those computed in other countries.

#### Keywords:

Life cycle assessment; cement; sustainability; energy; carbon dioxide emission

## 1 INTRODUCTION

With an annual production of about 280 million tonnes and about 200 large cement plants (with more than a million tonne capacity each), India is the second largest cement producer in the world. Assessment of the current scenario leads to the reasonable assumption that over the medium and long term, there will be an increasing trend in both cement and concrete usage. This is also reflected in the report of the Working Group on Cement Industry constituted by the Government of India, which expects cement consumption to increase at the rate of about 10%, and the installed cement production capacity to exceed 1000 million tonnes by 2027 [1]. Such predictions are based on the fact that per capita cement consumption in India is about 180 kg whereas it surpassed 1 tonne/capita in China during the development boom [2]. The major usage of cement in India is in infrastructure projects (about 20%), public buildings (about 18%) and housing (about 42%) [2], the demand for all of which will continue to increase over the next few decades. In addition, the cement usage in road construction, which is currently low, is expected to become significant in the future [2].

Most of the cement production is in integrated plants that produce clinker as well as cement

though there are many grinding units that procure clinker to produce cement for supply in bulk or in bags. Due to logistic reasons, clinker production is primarily concentrated in four geographic clusters, where limestone is in abundance. These plants generally operate limestone mines under licence from the government. Some plants are also located near coal belts to reduce fuel transportation costs; 15-20% of the cost of cement production is attributed to coal, electricity and freight [1].

The energy consumption per tonne of cement has decreased over the years, not only due to more efficient and leaner production but mainly due to the increase in fly ash based portland pozzolana cement, which now accounts for about 67% of the total production, and blast furnace slag based portland slag cement, which accounts for about 8% [2].

The present study focuses on process mapping, and the energy and CO<sub>2</sub> emission assessment for cement production in India based on plant data. The peculiarities of the Indian cement sector are highlighted, and the need for assessing different systems are emphasized.

## 2 LIFE CYCLE ASSESSMENT (LCA)

### 2.1 Goal and Scope

The goal of the LCA here is to assess the energy required and CO<sub>2</sub> emissions from production of cement. Based on the limitations of the data available and discussions with industry representatives, 3 sets of system boundaries have been considered: Ground-to-gate, Gate-to-gate and that conforming to the Cement Sustainability Initiative (CSI). An unambiguous explanation of the processes considered for each system is as follows.

#### (i) Ground-to-Gate (Cradle-to-Gate) System

This system considers all impacts from the mines to the (exit) gate of the cement plant; energy requirements and CO<sub>2</sub> emissions (direct and indirect) from all processes involved in the production of cement are accounted for, including the extraction and transportation of all fuels & raw materials, and the production of electricity. However, energy and emissions from the production of alternative fuel and fly ash consumed are excluded. This system gives a complete (though rather academic) assessment, and is in accordance with most scientific literature. Nevertheless, most assumptions made and conversions are not relevant to Indian conditions and materials, which distort the results considerably.

#### (ii) Gate-to-Gate System

Only processes attributed directly to the cement plant are considered in this system. All raw material and energy required, and emissions are considered from all processes within the plant, including the extraction and transportation of limestone and the production of electricity. The extraction and transportation of fuel are excluded. This system provides data for reliable comparisons with that compiled by the industry, and avoids assumptions that are not relevant to local conditions.

#### (iii) CSI System

This system considers only operations that occur within the perimeter of the cement plant. It includes the energy required and CO<sub>2</sub> emissions related to the limestone extraction, and the use of fuels within the cement plant. However, the extraction of raw materials and transportation outside the plant, the electricity production (both on site and purchased) and impacts of alternative (biomass and waste) fuels are excluded. This system facilitates comparison with Indian cement industry data and the CSI database [3]. The values are based on measurable quantities at the plant level, and no assumption is made that is irrelevant to local conditions. This is needed not only to assess the impacts of existing cements but also to compare the impacts and different alternatives proposed [e.g., 4, 5].

In accordance with the above boundary definitions, Table 1 lists the sub-processes accounted for and excluded in each of the systems, where the columns (i), (ii) and (iii) denote the three systems, respectively.

Sub-process	(i)	(ii)	(iii)
Extraction of limestone	✓	✓	✓
Transportation of limestone	✓	✓	×
Extraction of clay and other materials (bauxite, hematite, ferrite, etc.)	✓	×	×
Transportation of clay, gypsum, fly ash and other materials	✓	×	×
Extraction of fuel	✓	×	×
Transportation of fuel	✓	×	×
Production of electricity	✓	✓	×
Limestone crushing	✓	✓	×
Preparation of raw meal	✓	✓	×
Processing of fuel (for coal mill)	✓	✓	×
Preparation of clinker	✓	✓	✓
Grinding of cement	✓	✓	×
Packing of cement	✓	✓	×
Services (lighting of installations and other facilities, living quarters, etc.)	✓	✓	×

Table 1. System boundaries

### 2.2 Life Cycle Inventory (LCI)

The second step in LCA is the Life Cycle Inventory Analysis (LCI). There are many inventories that exist for cement, such as the popular ecoinvent 3 database [6], accessible through the SimaPro software [7]. However, existing inventories are heavily dependent on local materials and processes, and are not directly applicable to other geographical regions. Further, the use of existing databases for assessing cement production in India is especially unreliable due to the following:

- The raw material input in the clinker is often dominated by limestone, without much input of other materials such as clay, marl, shale, etc., which are common elsewhere.
- Limestone mines are directly managed by the cement companies and the clinkerization units are located near the mines. Therefore, there is little wastage of limestone since the composition of the raw meal is optimized by mixing different qualities of limestone. Further, transportation between the mines and the plant is minimal.

- Most Indian clinkerization units use the dry process so the process water [8] and overall water consumptions of cement are low.
- Electricity in India is produced mostly (70% or more) by burning coal. Therefore, the use of electricity does not necessarily lead to lower impact unless it is generated by alternative sources in the plant or elsewhere.
- Phosphogypsum, a waste product from the fertilizer industry, is used to a large extent instead of natural gypsum.
- There is substantial use of industrial waste and biomass as alternative fuels for meeting the thermal energy requirement; in some plants, as much as 10%.

Therefore, it is ideal that an inventory be compiled for typical plants in India so that conclusions regarding the industry can be made more reliably. The process of compiling a thorough inventory is tedious and the data gaps [e.g., 8] may require assumptions to be made that limit the reliability of the database. However, this is not easy or even feasible most of the time. In the present study, the following hierarchy of data sources is proposed to compile the inventory (with reliability or priority reducing in the descending order):

#### *Data sources for energy requirements*

- Experimental data – Bomb calorimetry of fuels; Thermogravimetric analysis and differential scanning calorimetry of the raw materials
- Reports of the cement plant, say those made for the CSI assessment [9]
- Environmental Protection Agency (EPA) emission factors for greenhouse gas inventories [10]
- Intergovernmental Panel on Climate Change (IPCC) 2006 guidelines for National Greenhouse Gas Inventories [11]
- The ecoinvent 3 database [6]

#### *Data sources for CO<sub>2</sub> Emissions*

- Experimental data – CHNS elemental analysis of the fuel or other chemical analysis to provide carbonate and organic carbon content, and to assess the composition of the organic matter
- EPA Emission factors for greenhouse gas inventories [10]
- The CSI Protocol [9]
- IPCC 2006 Guidelines for National Greenhouse Gas Inventories [11]
- The ecoinvent 3 database [6]

### **2.3 Life Cycle Impact Assessment (LCIA):**

The LCI results are used for the Life Cycle Impact Assessment (LCIA), in the third step in LCA. As mentioned earlier, the energy consumption and global warming are considered as the critical impact categories in this work. The

impacts are quantified in terms of the energy consumption (MJ/Tonne of cement) and CO<sub>2</sub> emissions (kg/Tonne of cement), respectively. Here, the impacts of ordinary portland cement (OPC) and fly ash blended portland pozzolana cement (PPC) have been evaluated and compared.

### **3 CASE STUDY**

The region of Ariyalur, Tamil Nadu, India, which has rich limestone deposits, was chosen for a case study. The integrated plant assessed has a leased limestone quarry for its use. Since the limestone is soft in this region, it is extracted by excavation without blasting, and has an average composition with about 44% CaO, 12.5% SiO<sub>2</sub>, 10% moisture and 35.5% loss on ignition. For the PPC, it is considered that Class F Fly ash is transported from the Mettur Power Plant (over 200 km), with a composition of 61% SiO<sub>2</sub>, 27% Al<sub>2</sub>O<sub>3</sub> and 4% Fe<sub>2</sub>O<sub>3</sub>, and incorporated at 28% by weight of PPC. Phosphogypsum, transported from Tutticorin (385 km), is used in the cement.

Based on detailed site visits and discussions with plant personnel, process maps were developed and relevant available data was collected.

#### *Process maps*

The manufacturing of cement can be sub-divided broadly into four major phases, namely the preparation of raw meal (i.e., input for clinkerization), preparation of clinker, production of cement, and packing of cement. Figure 1 shows the process map from extraction of limestone up to the stocking of the raw meal silo. Figure 2 covers the process up to clinker production. Figure 3 gives the process of transforming the clinker to OPC. In the case of PPC, the fly ash is fed into the horizontal ball mill for blending/grinding. Figure 4 shows the process until dispatch (i.e., exit gate of the plant) of the cement in bulk and bags.

#### *Energy and CO<sub>2</sub> emissions*

Following the principles outlined in the previous section, the inventories were compiled, and the energy and CO<sub>2</sub> emissions were computed for OPC and PPC fabricated in the same plant. Results for the gate-to-gate and CSI systems are given, respectively, in Tables 2 and 3. The gate-to-gate values indicate that the OPC in this plant requires significantly less energy than those of typical plants elsewhere, for example, the value of 4220 MJ/tonne reported for the US [8]. Similarly, the CO<sub>2</sub> emissions are also lower; 852 kg/tonne has been reported for the US [8]. The CSI compatible data in Table 3 show that the energy and CO<sub>2</sub> values obtained are lower than the gate-to-gate values since some impacts, such as that of energy production with alternative fuels, are excluded. In all cases, PPC gives lower impacts, as expected, since fly ash is not

attributed with any impact during its production. Note that average values for India, as reported by CSI, in 2012 are 2400 MJ and 580 kg of energy and CO<sub>2</sub> emissions per tonne of cement, corresponding to a clinker factor of 70.5%, which again indicate that the plant considered is relatively more efficient.

Impact/tonne of cement	OPC	PPC
Energy consumed or Embodied energy (MJ)	3760	2940
Emission of CO <sub>2</sub> (kg)	790	600

Table 2: Gate-to-Gate System Output.

Impact/tonne of cement	OPC	PPC
Energy consumed or Embodied energy (MJ)	2585	1935
Emission of CO <sub>2</sub> (kg)	695	520

Table 3: CSI Compatible System Output.

#### 4 CONCLUSIONS

An attempt has been made to perform an appropriate life cycle assessment on cement production in India, in accordance with the guidelines of the ISO 14040 standard. A typical integrated cement plant that produces both OPC and PPC has been assessed as a case study. Generic process maps of cement production have been drafted, and the energy consumption and CO<sub>2</sub> emission have been calculated following a proposed framework. The energy and emission values seem to be comparatively lower than the values reported in the literature for other locations.

#### 5 ACKNOWLEDGMENTS

The authors are grateful for partial funding from the Swiss Agency for Development and Cooperation through the project on Low Carbon Cement (ref. 7F-0857.01.02) with EPFL, Lausanne. Suggestions and help given by Profs. Karen Scrivener (EPFL), Guillaume Habert (ETHZ) and Shashank Bishnoi (IITD) are sincerely appreciated.

#### 6 REFERENCES

1. Indian Bureau of Mines, Indian Minerals Yearbook 2014, Part-III: Mineral Reviews, Cement. 2015, Ministry of Mines, Govt. of India, [http://ibm.nic.in/writereaddata/files/1218201514339IMYB-2014\\_Cement%28Adv%29.pdf](http://ibm.nic.in/writereaddata/files/1218201514339IMYB-2014_Cement%28Adv%29.pdf) (accessed 31st Jan. 2016), 21 p.

2. RajyaSabha Secretariat, Parliament of India, Performance of Cement Industry, 95th Report. 2011,

[http://dipp.nic.in/English/Performance\\_Cement\\_Industry.pdf](http://dipp.nic.in/English/Performance_Cement_Industry.pdf) (accessed 31st Jan. 2016), 117 p.

3. World Business Council for Sustainable Development, CO<sub>2</sub> and Energy Accounting and Reporting Standard for the Cement Industry, version 3.0. 2011, [http://www.wbcscement.org/pdf/tf1\\_co2%20protocol%20v3.pdf](http://www.wbcscement.org/pdf/tf1_co2%20protocol%20v3.pdf) (accessed 31st Jan. 2016), 80 p.

4. Scrivener, K., Options for the future of cement. *Indian Concrete J.*, 2014. 88(7): p. 11-21.

5. Barcelo, L., J. Kline, G. Walenta and E. Gartner, Cement and carbon emissions. *Materials and Structures*, 2014. 47: p. 1055-1065.

6. ecoinvent Centre. <http://www.ecoinvent.org> (accessed 31st January 2016).

7. PRé Consultants, SimaPro LCA software. <https://www.pre-sustainability.com/simapro> (accessed 31st Jan. 2016).

8. Marceau, M., M.A. Nisbet and M.G. VanGeem, Life cycle inventory of portland cement manufacture, Report SN2095b. 2006, Portland Cement Association, Skokie, Illinois, USA, 69 p.

9. World Business Council for Sustainable Development, The Cement Sustainability Initiative, Progress Report. 2012, [http://csiprogress2012.org/CSI\\_ProgressReport\\_FullReport.pdf](http://csiprogress2012.org/CSI_ProgressReport_FullReport.pdf) (accessed 31st Jan. 2016), 32 p.

10. U.S. Environmental Protection Agency, Emission factors for greenhouse gas inventories. 2015, [http://www.epa.gov/sites/production/files/2015-12/documents/emission-factors\\_nov\\_2015.pdf](http://www.epa.gov/sites/production/files/2015-12/documents/emission-factors_nov_2015.pdf) (accessed 31st Jan. 2016), 5 p.

11. Garg, A., K. Kazunari and T. Pulles, 2006 IPCC Guidelines for National Greenhouse Gas Inventories. 2007, <http://www.ipcc-nggip.iges.or.jp/public/2006gl/vol2.html> (accessed 31st Jan. 2016), 29 p.

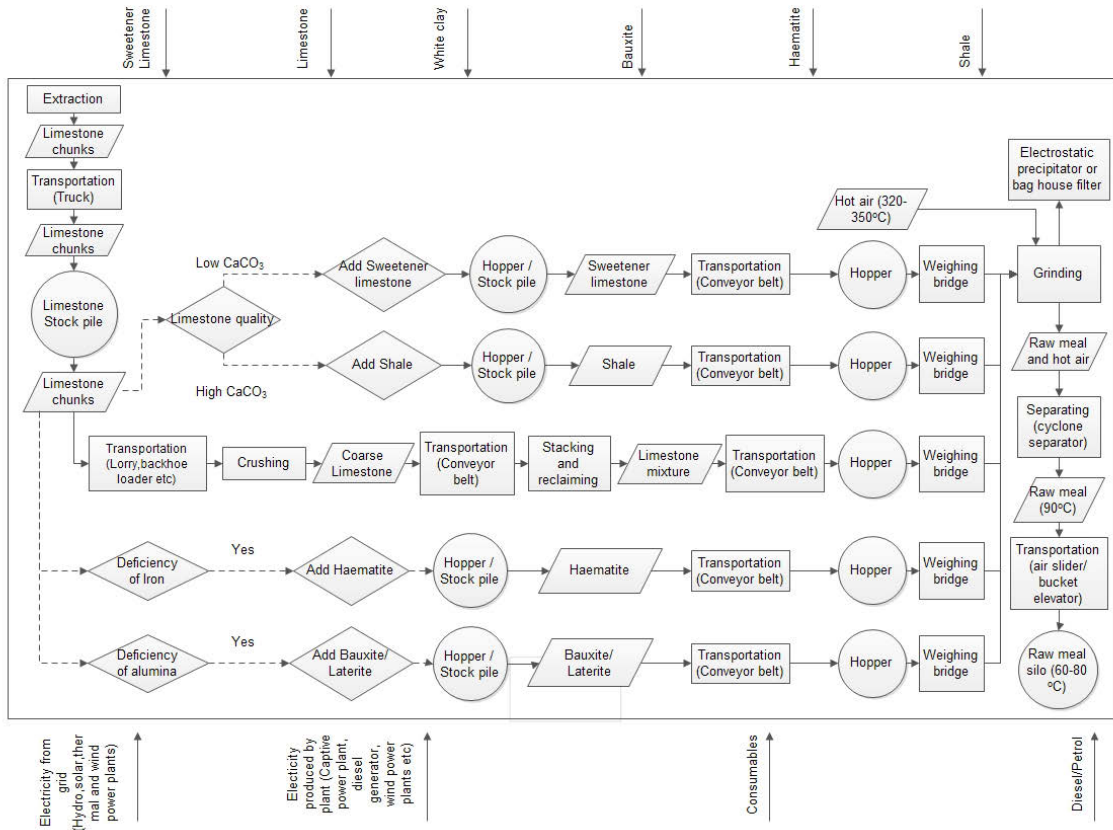

Fig. 1: Preparation of Raw Meal.

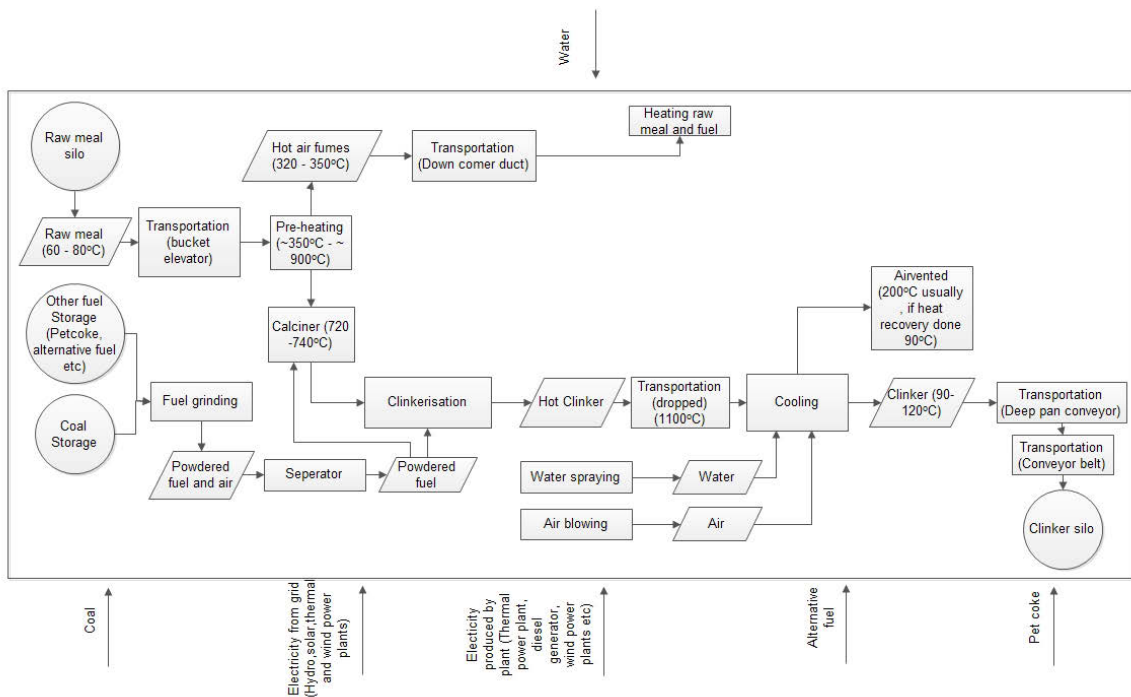

Fig. 2: Production of Clinker.

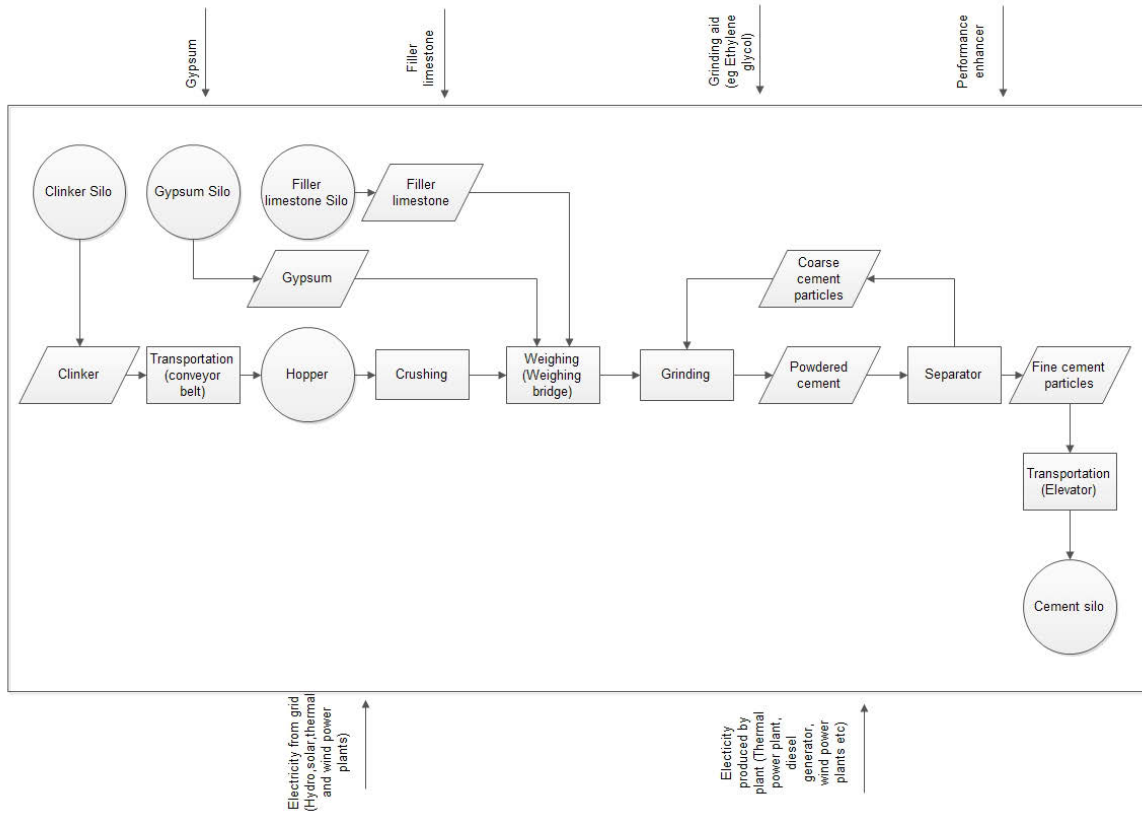

Fig. 3: Production of Ordinary Portland Cement.

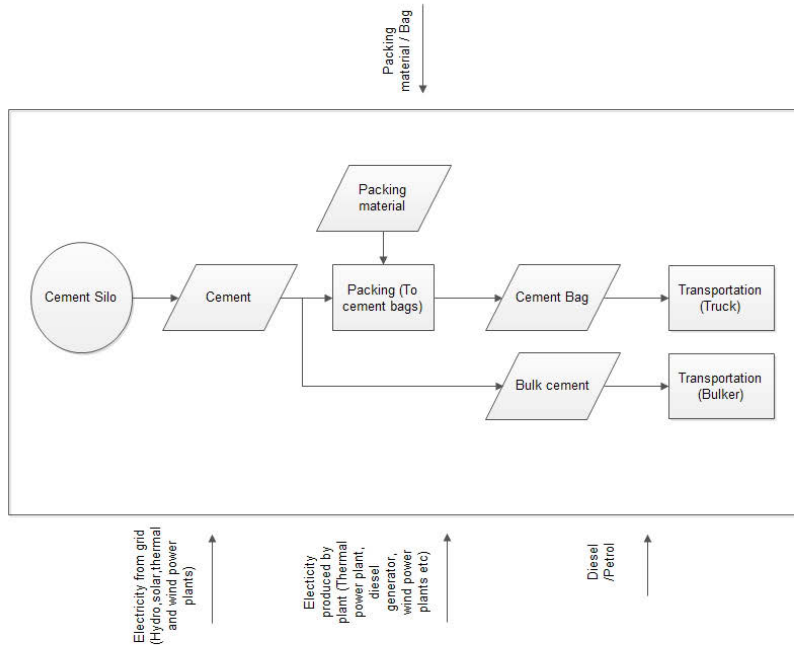

Fig. 4: Packaging of Cement.



## Expanding Boundaries: Systems Thinking for the Built Environment

### THE ENVIRONMENTAL RELEVANCE OF THE CONSTRUCTION AND END-OF-LIFE PHASES OF A BUILDING: A TEMPORARY STRUCTURE LCA CASE STUDY

A. Arrigoni<sup>1\*</sup>, D. Collatina<sup>1</sup>, M. Zucchinelli<sup>1</sup>, G. Dotelli<sup>1</sup>

<sup>1</sup> Politecnico di Milano, Dipartimento di Chimica, Materiali e Ingegneria Chimica, Piazza Leonardo da Vinci 32, Milano, 20133, Italy

\*Corresponding author; e-mail: [alessandro.arrigoni@polimi.it](mailto:alessandro.arrigoni@polimi.it)

#### Abstract

LCA can prevent shifting the environmental burden of a building to peculiar life cycle phases. Components production and demolition stages became much more relevant in new low-energy buildings. The same applies also to temporary structures, whose useful service life is generally limited to the duration of the related event. More attention must therefore be paid to the choice of the construction materials and the way they are assembled in order to reduce resource depletion, embodied energy and waste production. To achieve this goal, it is essential to act in the design phase of the building in order to include environmental problems in the early stages of the decision making process. The objective of our study is to assess the environmental impacts of the different life stages of a temporary structure to support the design phase of future ones. The reference case study is the Brazilian pavilion constructed in Milan (Italy) for EXPO 2015. The aim of the research is to evaluate how much the design phase of the building, the choice of the materials and the end-of-life scenarios can influence the environmental performances of the structure. Primary data for the whole lifecycle are considered and a sensitivity analysis on the materials sustainability is performed. LCA results confirm the importance of the design phase for temporary structures. The predilection of natural and recycled materials in the construction phase and the prevision of a second life significantly reduce the impacts of the building. Among the end-of-life scenarios the best environmental solution proves to be the refunctionalization on site. The priority must be therefore to foresee a second life of the components at an early stage of the decision-making process. Similar conclusions could be expected for low-energy buildings too.

#### Keywords:

LCA; temporary building; demolition phase; end of life

#### 1 INTRODUCTION

IPCC recently reported that the building sector accounts for about 32% of global energy use and for about 19% of greenhouse gas emissions [1]. These numbers are constantly increasing and many countries started to adopt policies aimed at decreasing the energy requirements of the buildings during their use phase. However, the buildings' environmental impacts extend beyond the use phase, including the burdens related to the production phase and the end of life (EOL). In low-energy buildings these phases become more relevant compared to the operational energy, traditionally the main source of buildings' environmental impacts [2, 3]. The vast majority of LCA studies on buildings focus on the use phase,

but several studies have been performed to assess the environmental impacts of the *minor* lifecycle stages: production and EOL [4-7]. The importance of the choice of the materials has also been assessed [8, 9]. Thorough low-energy buildings LCA are difficult to perform because of their EOL, hard to predict and with an allocation methodology of the impacts non-standardized [10-12]. A proxy for these buildings are temporary structures, whose useful service life is generally limited to the duration of the related event and whose EOL is very close in time and easy to predict [13, 14]. The LCA of a temporary pavilion built for the international exposition held in Milan (Italy) from May to October 2015 is performed in order to understand the importance in the choice of the materials and the design phase of the

building. Different scenarios for the temporary structure's EOL (refunctionalization, reuse of building components, recycling of building materials) are studied in order to determine the best solution to apply at the end of the international event. The results could be reasonably extended to new low-energy buildings.

## 2 MATERIALS AND METHODS

### 2.1 LCA

#### *Methodology*

The LCA study was performed according to ISO standards [15, 16]. Allocation rules for the input of recycled materials and the management of wastes refer to the General Programme Instructions for the international Environmental Product Declaration (EPD) system [17], in line with the Ecoinvent cut-off system model [18]:

- recyclable materials in input to the system: available burden free at the beginning of the recycling treatment processes
- recyclable materials in output to the system: the only burdens allocated to the system are the dismantling processes and the transport of the recyclable materials to the processing site
- wastes: the producer is fully responsible for the disposal of its wastes

#### *Functional unit*

The functional unit considered is the temporary pavilion built for the major international event EXPO. To pinpoint the most impacting phase of the structure's lifecycle, a study period equal to the duration of the event and the hypothesis that all the materials are sent to the recycling collection site at the end of the event were considered. Furthermore, to allow a comparison of different scenarios for the pavilion's EOL a reference study period of 10 years, according to the indicative design working life for temporary structures in [19], is considered.

#### *System boundaries*

The life of the building is divided in the stages proposed by the EN 15978 [20]. The processes considered, in a "cradle to grave" approach, are the following:

- Product stage: raw material supply, transport and manufacturing
- Construction stage: transport to site, construction and waste processing
- Use stage: operational energy and water use
- End of life stage: deconstruction, transport, waste processing and disposal

When the role that the choice of the post-event scenario, and all the building techniques related to

this choice, plays in the overall environmental sustainability of the structure is investigated, a study period (10 years) longer than the required service life of the structure (6 months) is chosen. System boundaries are therefore extended from the first use of the building to a 10 year lifetime, including its second use. If the temporary building is not reused after the event, the same methodology considered in the EN 15978 is applied: scenarios for demolition and construction of an equivalent new building are developed. These scenarios provide for an extension of the service life which, when combined with the required service life of the object of assessment, is equal to or more than the reference study period. Another temporary building with the same characteristics shall be therefore considered to cover the reference study period.

#### *Data quality*

Primary data are considered for the materials employed: the vast majority of the data have been directly collected on site through the transport delivery notes and the remaining (about 5%) have been estimated from the building's drawings. HVAC system, water pipelines, kitchen and bathrooms' equipment and furniture were excluded from the system. When available, the environmental impacts of the production processes declared in the EPD certification of the materials used on site were considered. To these values, the impacts related to the transportation from the company gate to the construction site were added. When the EPD certification of the material was not available, we referred to the Ecoinvent database [18]. Information on transports' distances were collected on site and the Ecoinvent database was used to assess the emissions of the trucks. Primary data for the energetic and water consumptions during the construction phase were used. The average energy consumption of a pavilion, declared by the event's energy provider, was considered for the use phase (24 MWh per week). Finally, the energy needed for the dismantling process was assumed to be equal to the one used in the construction phase.

#### *Impact categories*

The impact assessment is carried out for the environmental impact categories recommended by EN 15978 (abiotic depletion (ADP), fossil fuels depletion (ADP fossil), global warming in a time interval of 100 years (GWP), ozone depletion (ODP), acidification (AP), eutrophication (EP), photochemical ozone creation (POCP)) with the characterization factors proposed by the CML institute.



Impact category	Unit	Production	Prod. (no rec, no EPD)	Construction	Use	EOL (recycling)	Total lifecycle
ADP	kg Sb eq.	20.3	52.5	0.00	0.00	0.00	20.3
ADP fossil	TJ	36.3	53.4	2.55	4.89	1.01	44.8
GWP	kton CO2 eq.	2.96	4.69	0.17	0.36	0.07	3.55
ODP	g CFC11 eq.	254	315	30.9	47.1	12.3	344
POCP	ton C2H4 eq.	0.93	2.15	0.03	0.07	0.02	1.05
AP	ton SO2 eq.	13.4	23.2	1.04	1.47	0.58	16.5
EP	ton PO4 eq.	5.24	11.8	0.21	0.25	0.13	5.82

Table 1 : CML-IA Baseline results.

## 2.2 Building

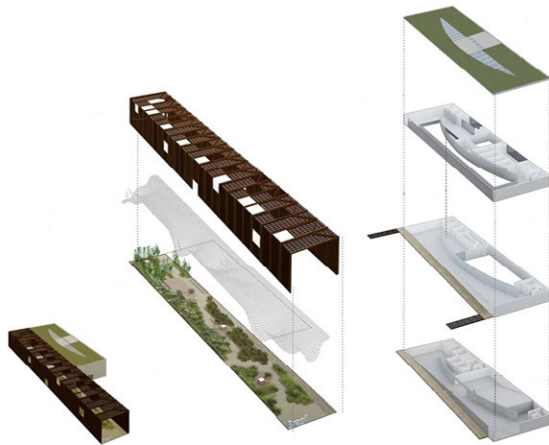

Fig. 1: Brazilian pavilion for EXPO 2015.

The building, shown in Fig. 1, is composed of two parts: a conventional covered structure on three floors (net surface area: 2802 m<sup>2</sup>), and an open gallery traversed by an elevated net on which visitors can walk (net surface area: 1125 m<sup>2</sup>). The total estimated mass of the building is about 5 kiloton (kton) and the materials used in the structure are presented in Fig. 2. Attention to sustainability has been paid by the designers in the selection of materials, choosing for many components materials with a high recycled content or with an EPD. Moreover, during the construction, dry assembly techniques have been used to allow an easy disassembling at the end of the event, guaranteeing therefore the possibility of reusing the components.

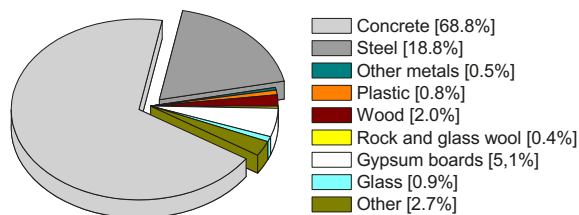

Fig. 2: building materials.

## 3 RESULTS

### 3.1 Life cycle phases

In Table 1 the impacts of the different lifecycle phases of the pavilion are presented. Results point out that the pre-use phase of a temporary building overshadows the rest of the lifecycle, confirming the conclusions of Lavagna et al. in [13]. The pre-use phase contribution ranges from a minimum of 73.8% for the ODP impact category to a maximum of 99.9% for the ADP. The major contributor is the steel, used both in the covered structure (S355) and in the gallery (weathering steel). The impact of steel varies from 19.3% for ADP to 56.7% for ODP, with the latest due to the release of Halon gases in the fire-fighting and refrigeration systems in the production of oil and gas used to generate electricity consumed in the electric arc furnace (EAF) for secondary steelmaking. The highest share of emissions, responsible for most of the other environmental impact categories, derives instead from the combustion of fossil fuels used to produce electricity consumed in the production of steel. An important contribution to the ADP (26%) stems from the galvanized steel used in the dry floors, due to zinc depletion. The contribution of the transportation phase has a maximum of 5.3% for the ODP due, again, to the emissions in the oil production sector. Most of the building materials (85%) are sourced from a range lower than 350 km and just 7% from a range larger than 1000 km. It is worth noting that the latter represents only 1% of the total mass, but have a significant contribution to the whole transport stage impact (i.e. 12% of the GWP). The construction phase, including fuel consumption and waste disposal, has a maximum impact of 3.8% for the AP category, due to the sulphur dioxide emissions in the fuel combustion. The use phase reaches a maximum impact in the ODP (13.7%). Finally, the EOL phase, considering a scenario where all the materials are sent to the recycling collection site, contributes for a maximum of 3.6% (ODP) to the total lifecycle.

### 3.2 Construction materials

The second column of the production phase in Table 1 show the impacts of an equivalent pavilion

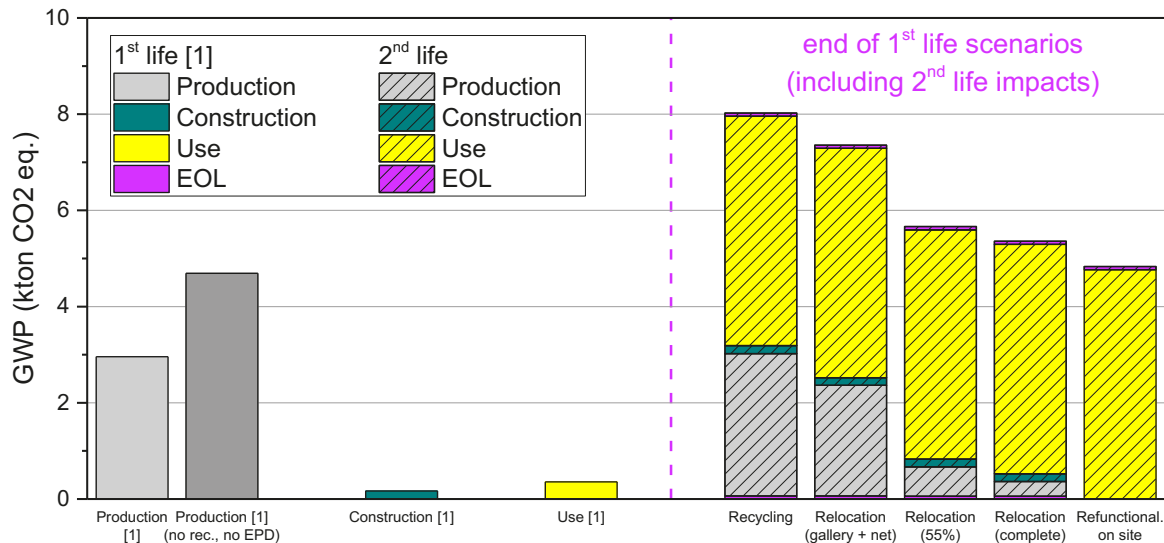

Fig. 3: GWP lifecycle stages.

made with standard construction materials: the recycled component of the materials in input to the system is substituted with virgin matter and the materials with EPD are substituted with standard materials from the Ecoinvent database. The use of recycled and sustainable materials leads to a reduction of the impacts in a range that goes from 19.4% of the ODP to 61.3% of the ADP. The reduction is mainly due to the lower impact of the production of steel from scrap in the electric arc furnaces, compared to the virgin steel produced in blast furnaces.

### 3.3 EOL Scenarios

A comparison among different EOL scenarios is assessed in order to understand the role this phase could play in the whole LCA. The scenarios considered are: refunctionalization of the pavilion on site, relocation of the structure elsewhere and dismantling with all the materials sent to the recycling collection site. Landfilling was not considered as an option because, according to the builders, all the materials used in the building could be recycled at the event. The last 5 columns in *Figure 3* show that, among the scenarios considered, the one with the highest impacts is the recycling option. The partial reuse of the pavilion (open gallery and net) in a different location (100 km away from the event's site) allows a reduction in the GWP impact, compared to the recycling option, of 6%. On the other hand, reusing the share of the materials that are easy to disassemble in the dismantling process (about 55% of the total) leads to a reduction of 21% of the GWP emissions. The ideal relocation case, considering a complete reusing of the building components, prevent the 23% of the greenhouse gas emissions. Results show, however, that the best solution for the options considered is the refunctionalization of the building on site. Extending the service life of the structure to 10 years guarantees a reduction of the GWP of 28%.

The reductions are due to the avoided emissions generated in the production of the materials used for the post-event equivalent pavilion (as shown by the patterned grey stack in the columns in *Figure 3*).

## 4 DISCUSSION

The comparison of the impacts in the lifecycle stages of the pavilion highlights the role that the production of the building materials plays into the overall sustainability. Using *green* materials allows to substantially reduce the emissions in this lifecycle stage. Even though the EOL phase has a small impact compared to the whole lifecycle in terms of direct emissions, the study highlights that the planning of a second life for the pavilion could lead to important environmental benefits. Bearing this in mind, it is necessary during the design phase to foresee a possible second life and to allow the reuse of materials at the end of the event.

## 5 CONCLUSIONS

The goal of the study was to increase the awareness of architects and designers about the environmental impacts associated with the construction of buildings for temporary events. It is unthinkable nowadays to design disposable buildings, with a service life linked to the duration of the event. It is necessary to imagine a sustainable and adaptable structure during the design phase. This way of thinking, called Design for Environment (DfE), stresses the importance to consider, in the design stage, future needs of the community and the surrounding environment. The DfE includes the selection of materials and the use of dry construction techniques. The life cycle environmental impacts can be significantly reduced if the structural components of a building are designed to be durable and reusable.

Additionally, using sustainable materials, either with a high recycled content or with an environmental declaration, would reduce the most impacting phase of buildings with a short service life. The same applies to low energy buildings, whose environmental burden is usually shifted from the use phase to the production of the building components. The design phase has a strategic importance for the overall environmental impact but especially for the EOL phase, highly influenced by the decisions made in the early stages of the work. The objective should be the refunctionalization of the structure, extending its service life as much as possible. The study highlights that a proper design of the structure could lead to a reduction of the environmental impacts, combining choice of the materials and service life extension, of more than 40% of the whole building lifecycle. It is important to highlight that the best environmental option can only be achieved with the intervention of the city organizing the event.

## 6 SUMMARY

The Brazilian pavilion built for the international event EXPO 2015 has been used as reference case study to understand the role that the design phase and the selection of the materials play in the lifecycle sustainability of the building. Choosing sustainable materials and foreseeing a second use for the building at the end of the event could almost halve the lifecycle environmental impacts over a lifespan of 10 years.

## 7 ACKNOWLEDGMENTS

The authors would like to thank the architecture and engineering studio Mosae and the construction company Mantovani group for all the information and the cooperation.

## 8 REFERENCES

1. Lucon, O., et al., *Climate Change 2014: Mitigation of Climate Change. Contribution of Working Group III to the Fifth Assessment Report of the Intergovernmental Panel on Climate Change*, C.U. Press, Editor. 2014, Intergovernmental Panel on Climate Change: Cambridge, United Kingdom.
2. Blengini, G.A. and T. Di Carlo, *The changing role of life cycle phases, subsystems and materials in the LCA of low energy buildings*. Energy and Buildings, 2010. 42(6): p. 869-880.
3. Citherlet, S. and T. Defaux, *Energy and environmental comparison of three variants of a family house during its whole life span*. Building and Environment, 2007. 42(2): p. 591-598.
4. Blengini, G.A., *Life cycle of buildings, demolition and recycling potential: A case study in Turin, Italy*. Building and Environment, 2009. 44(2): p. 319-330.
5. Dewulf, J., et al., *Quantification of the impact of the end-of-life scenario on the overall resource consumption for a dwelling house*. Resources, Conservation and Recycling, 2009. 53(4): p. 231-236.
6. Ortiz, O., J.C. Pasqualino, and F. Castells, *Environmental performance of construction waste: Comparing three scenarios from a case study in Catalonia, Spain*. Waste Manag, 2010. 30(4): p. 646-54.
7. Pajchrowski, G., et al., *Materials composition or energy characteristic – What is more important in environmental life cycle of buildings?* Building and Environment, 2014. 72: p. 15-27.
8. González, M.J. and J. García Navarro, *Assessment of the decrease of CO2 emissions in the construction field through the selection of materials: Practical case study of three houses of low environmental impact*. Building and Environment, 2006. 41(7): p. 902-909.
9. Thormark, C., *The effect of material choice on the total energy need and recycling potential of a building*. Building and Environment, 2006. 41(8): p. 1019-1026.
10. Allacker, K., et al., *Allocation solutions for secondary material production and end of life recovery: Proposals for product policy initiatives*. Resources, Conservation and Recycling, 2014. 88: p. 1-12.
11. Fouquet, M., et al., *Methodological challenges and developments in LCA of low energy buildings: Application to biogenic carbon and global warming assessment*. Building and Environment, 2015. 90: p. 51-59.
12. Marinković, S.B., I. Ignjatović, and V. Radonjanin, *Life-cycle assessment (LCA) of concrete with recycled aggregates (RAs)*. 2013: p. 569-604.
13. Lavagna, M., et al., *The temporary structures for Expo Milan 2015: environmental assessment and solutions for the end of life management*. Techne. Journal of Technology for Architecture and Environment, 2014(7): p. 171-177.
14. Lavagna, M., et al. *La valutazione LCA di strutture temporanee per i grandi eventi: sviluppo di una metodologia di allocazione degli impatti degli scenari di fine vita*. in *ECOMONDO a mediterranean platform for the sustainable growth*. 2014. Rimini, Italy.
15. ISO, *ISO 14040:2006 Environmental management -- Life cycle assessment -- Principles and framework*. 2006.

16. ISO, *ISO 14044:2006 Environmental management -- Life cycle assessment -- Requirements and guidelines*. 2006.
17. Environdec, *GENERAL PROGRAMME INSTRUCTIONS FOR THE INTERNATIONAL EPD® SYSTEM 2.01*. 2013, EPD (International Environmental Product Declaration System): Sweden.
18. Weidema, B.P., et al., *The ecoinvent database: Overview and methodology, Data quality guideline for the ecoinvent database version 3*, [www.ecoinvent.org](http://www.ecoinvent.org). 2013.
19. CEN, *EN 1990:2002 Eurocode - Basis of structural design*. 2002.
20. CEN, *EN 15978:2011 Sustainability of construction works. Assessment of environmental performance of buildings. Calculation method*. 2011.



## Expanding Boundaries: Systems Thinking for the Built Environment

### OVERCOMING OBSOLESCENCE: A CASE STUDY RENOVATION BUILDING - IDEAS ON REUSE IN PLANNING AND BUILDING PROCESS

A. Hafner<sup>1\*</sup>

<sup>1</sup> Resource Efficient Building, Universitätsstr. 150 IC 5/159, Bochum, Germany

\*Corresponding author; e-mail: annette.hafner@rub.de

#### Abstract

In the context of sustainable buildings, closing lifecycle loops is ever more important. Energy efficiency in the use stage has long been the primary focus of these efforts. Recycling and reuse of building components that influence resource efficiency represent the next steps.

This paper presents a renovation building case study. With a main focus on planning instruments and managing reuse and recycling of existing buildings and their structural features, the methods and practicalities of a building's end-of-life stage are discussed in reference to the case study building. This exemplary residential renovation building demonstrates how recycling and reuse of building components could be planned, managed and implemented.

It first describes the existing building and the starting position. Then the planning process and the building process are explained. It details how much material was disposed of and which components were involved. Beside material itself also the pollutant content in different material types were monitored. Critical questions arise from the quality of the material. The planning process focused on how to influence a building's design in terms of easy recyclability and reasonable end-of-life scenarios. In a next step, practical implementation of reused material and components are outlined for the case study. In this example, reuse was possible for wooden flooring, tiles, sockets and switches, staircases, doors and handles, as well as energy recovery for all wooden material. Results also show under which premises material could be reused and which advantages and disadvantages arose from reuse decisions.

#### Keywords:

End-of-life; reuse; recycling; material flow; timber structures; lifecycle

## 1 INTRODUCTION

In the context of sustainable buildings, closing lifecycle loops is ever more important. In the building sector, energy efficiency in the use stage has long been the primary focus. Considering the division of lifecycle in stages according to EN 15978 [1], the focal point of the use stage has been on high-energy performance. In current building practice, highly insulated buildings with efficient building facilities are state of the art. In the product stage, energy consumption and emissions can be restricted through elaborate material choice. The end-of-life stage can be influenced by material choice and deconstruction options. It is linked to material in the product stage and can mainly be triggered through considerations made during the planning process at the beginning of projects. For building renovations, this process is

more difficult and needs a sophisticated approach. Here preliminary studies of the existing building are necessary (material, toxic substances, fire regulations, load bearing capacity). Additionally, the question of demolition and rebuilding, or otherwise renovating requires careful consideration. Results vary strongly depending on building types and the need to preserve listed buildings. No general conclusions can be made on renovation or demolition/rebuilding. The general condition of the building, reuse opportunities, and time and money constraints demand careful consideration in each case.

Therefore, this paper explains ideas on reuse based on an exemplary case study building.

Recycling and reusing building components influence resource efficiency. In this paper, resource efficiency is synonymously used for

efficient use of building material and is not defined according to the broad explanation of, for example, VDI [2]. Building components and structural elements can be separated and recycled in a controlled deconstruction process. By applying the Strategy for Resource Efficient Europe [3], accurate recycling, clearance of toxic substances, and lower waste accumulation, the environment and the resources can notably be preserved.

## 2 END OF LIFE OF BUILDINGS

This paper discusses the practicalities of a building's end-of-life stage with a focus on an existing building and its structures to overcome obsolescence. The explanations are broken down in:

- (i) Planning process: for renovation projects, in the first place, ideas for reuse and enhancement of the building are relevant. Questions arise from the aspired energetic standard, user requirements and possible new building uses.
- (ii) Managing reuse of buildings and their constructions: For renovation, the removal and disposal of construction waste, their amount, the cost, and possible toxic substance contamination are relevant factors.
- (iii) Reusing building materials: It explains how the reuse of building components was planned, managed, and implemented in a realized renovation of an exemplary inner-city residential building.

The paper explains the approach to the building's renovation and extension, in which considerations regarding how to achieve a sustainable solution played a leading role. This case study was built in Munich in 2013-2014, in a conservation area with high pressure on increasing residential living space.

## 3 CASE STUDY RENOVATION BUILDING

The initial building was a 3-story mixed-use building with a ground-floor shop and two small flats on the upper floors. The second floor was added at the end of the 1940s (postwar area) using very simple construction methods and a restricted choice of materials. Building facilities had not been renovated since the last interior renovations took place in the 1970s. The entrance to the building was located within a 2m-wide gap between the buildings. Due to its location in a conservation area, the extent of alteration to the façade and the height of the building were restricted. The maximal possible extension of the building could be achieved through loft conversion by lifting the cullies by 0,5m and closing the gap between buildings.

## 3.1 Planning process



Fig. 1: Existing building: street view and existing gap between buildings.

Figure 1 shows the then existing building with the narrow gap to the adjacent building. Different options were discussed during the planning phase, including renovating the existing house, renovating the ground and first floor, renewing second floor and roof, and closing of the gap to change the entrance situation and enlarge size of flats with the additional advantage of reducing façade to exterior. Complete demolition and rebuilding was not an option due to conservation area restraints.

Alongside the total renovation of the building, including replacing all windows and building facilities, closing the gap between the buildings with energy efficient façade over three stories and extending living space circa 35 m<sup>2</sup> was defined as minimum. Because toxic substances were found in the flooring of the ground floor, complete extraction and new ground floor slab with insulation were necessary.

Alternative planning scenarios included completely renewing the second floor and roof and extending the living area by about 35 m<sup>2</sup> (V0), or only renovating the building with a new, insulated roof (V1). Both scenarios were calculated to reach the same energetic level of 75 kWh/m<sup>2</sup>a. For scenario V0, an additional idea was rebuilding the two new stories with as much renewable material as possible and with an end-of-life concept in mind that permitted the reuse of sorted material. Therefore, structural elements were planned as cross laminated timber.

Figure 2 shows the results of lifecycle analysis calculations over 50 years per m<sup>2</sup> living space for erection, operation, and end-of-life. The calculations [4] were made according to the standard German sustainability assessment scheme BNB [5], ökobaudat 2011, and with program Legep. The green line shows the no-renovation scenario. Here, GHG emissions in operation exceed the renovation options within few years. Additional living area and the use of construction material with low GHG emissions (timber) give scenario V0 a slight advantage over

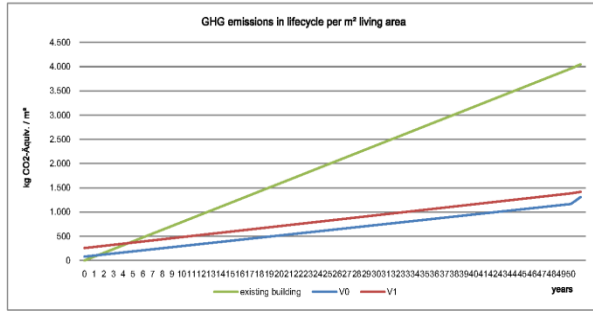

Fig. 2: GHG emissions of different scenarios in lifecycle per m<sup>2</sup> living area.

V1. The steep increase of emissions in V0 at the end-of-life originates from energy recovery of the timber and thereby produced GHG emissions.

Scenario V0 was ultimately built and all further remarks in this paper are based on that scenario. Lifecycle analysis assisted in deciding on the most favourable scenario.

### 3.2 Demolition process

Scenario V0 meant demolishing the second floor, chimney, and roof, completely replacing the floor slab (ground floor), demolishing concrete pavement in gap between buildings, and renewing the sewage inspection chamber. Due to current fire regulations and improvements in sound protection only structural elements remained on the first floor. During building work, the plaster quality was discovered to be very poor, meaning it also had to be replaced. All demolition material was calculated according to bills of quantities and is summarized in Table 1 – divided in different material types. The means of disposal are also shown.

Tests on potentially toxic substances were conducted and results showed high contamination of PAH in materials used in ground floor construction. It was not an option to leave toxic substances in the building and these materials had to be extracted under high security and adherence to health and safety measures.

Although the material mass of extracted toxic material was relatively small, expenses accounted for 33% of total demolition cost. Table 1 shows the percentage of cost for each type of material compared to total demolition cost. Costs were calculated by exact bills of companies and include costs of labour, containers, and waste disposal.

Material output	disposal	% of total demolition cost
Demolition waste	(1)	44
Soil excavation	(1)	20
Timber	(2)	0
Steel sheet	(3)	3
Toxic substances	(4)	33
	(12,9 T)	

With (1) building debris dump, (2) incineration with energy recovery, (3) special sorting, then recycling, (4) special treatment by waste management

Tab. 1: Extracted demolition material calculated with bills of quantities.

### 3.3 Managing reuse of buildings and their constructions

As the author was part of the planning team, detailed insight into the process can be provided. The main design idea was not only to conserve the atmosphere of the existing building, but also to upgrade it to current standards. Aim of the renovation was to reuse as much extracted material as possible.

In this case study, reuse of wooden flooring, tiles, sockets and switches, staircases, internal doors, and handles was possible, as well as, on the waste management side, energy recovery for all wooden material. Windows were in poor condition and could not be renovated. Nearly half of the wooden flooring could be reused for window benches and interior works. As the floorboards had been painted several times, some work was needed to strip the paint. Additionally, it took time to find a carpenter who would agree to reuse material rather than introduce only new material. The interior doors and door-frames were removed and stored offsite. They were later remounted, sanded, and painted. Style-appropriate door handles and window handles were also mounted. All handles were relocated from other demolished buildings. The old wooden staircase only needed some cleaning and amendment. Sockets and switches were also collected from various other buildings. They needed to be completely cleaned and inspected, before being mounted again throughout the building. An open-minded electrician with a passion for environmental issues enabled this reuse. This, however, meant that labour time to install them increased and completely negated the saved material cost. Interestingly, 12mm thick tiles from the last renovation (end of the 1940s) could, due to their thickness, be removed and cleaned of cement quite easily without much damage. Only one third broke or could not be reused. All intact tiles were

mounted after proper cleaning and are now an interesting feature of the building.

All wooden building material from the roof and floors was set aside for energetic recovery. As most of the wooden roof material had been treated with chemical wood protection, energetic recovery was therefore the only option.

In general, only a small part of the building material could be incorporated in a second lifecycle. In all cases of reuse, additional labour was necessary to renovate the extracted material. Thus, additional labour costs negated saved material costs. Especially for private clients, however, such an approach could offer an interesting option for on-site self-work and integrating do-it-yourself practices.

Figure 3 shows the bill of quantities for the renovation building (left) and material output and input for a fictional new building, that in addition to

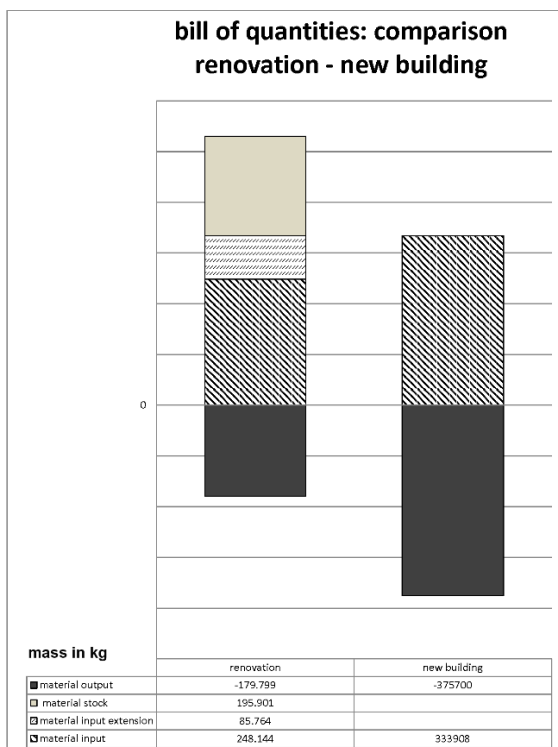

Fig. 3: Bill of quantities: Comparison renovation new building.

much higher amount of demolition waste, would also require a higher material input. This amount of demolition waste and new building material needs to be considered, when deciding on the most favourable option. In case of resource efficiency, renovation generally proves most favourable.

### 3.4 Material concept of renovation building

The planning target was to reuse as much material as possible. This also meant that it was important to focus on easy recyclability and possible correctly sorted reconstruction in detailing the new construction. During the planning process, the following questions arose: Is the construction

easy to redo and can material types be separated completely. Are chemicals in paint and/or glues introduced? Can construction layers be omitted?

Regarding the material concept, the structural elements for the second floor and roof are made of CLT, and were neither further cladded with gypsum board nor painted. All the floors in the house are made of cement screed and are only embedded with sodium silicate. At the end-of-life stage, screed must first be crushed, and then chipped and sorted by an air pressure machine, whereby light parts (plastic tubes of floor heating) are sorted. Plasterboard was only used for vertical shafts (fire regulations) and necessary horizontal front-wall installation in bathrooms. The main focus for all building facilities was on realizing short routes and compact construction. Only the minimum necessary equipment was used: gas calorific value boiler for heating and warm water, and ventilation with heat recovery.

New construction to close the gap between the buildings consists of concrete wall (requirement for fire safety), internal prefabricated concrete staircases, and large triple-glassed windows with wood-aluminium frames on both façades. Windows facing the street were designed as wooden frames in historic style.



Fig. 4: Street view of renovated building.

Connections were optimized through focusing on low material consumption. For example, interior doors were fixed directly in the CLT walls without extra wooden doorframes. This was possible due to the high precision of CLT prefabricated walls. Thereby the decision was taken that no door sealing was to be used, which then resulted in a lower sound protection standard. However, given required air-gap ventilation, doors here couldn't have been sound protective anyway. Such small adjustments helped in rethinking material consumption and desired standards.

During the planning process, end-of-life options and demolition process were also discussed. Set parameters for material were: (i) check material input on toxic substances (here paint, glue, etc.);





*Fig. 5: View from inside (loft extension) showing reduced material concept.*

(ii) use only a small variety of materials; (iii) rethink construction, especially joints. This delivered a reduced material concept using as much non-treated material as possible. For example, frames for doors were left out as the hocks also could be connected to the wooden walls. The wooden construction is only fixed by easily replaceable screws and steel brackets. Only the insulation of exterior façades (wooden soft fibre board) is inseparably connected to rendering.

## 4 RESULT

### 4.1 General

The renovation project made it possible to extend the living area of the upper flat from 45 to nearly 120 m<sup>2</sup>. Presently, a four person family and couple (first floor flat) inhabit the house.

Rethinking the design process by paying careful attention to demolition and sorting accuracy strengthened the design concept of reducing material selection and material consumption.

The paper shows the demolition material flows of the building. The input material was additionally calculated and compared to a new erection. All building facilities had to be renewed. As these building facilities are essential for long usage of building, their renewal helps to extend the service life of the building.

### 4.2 Material

When planning a renovation, early investigation of toxic substances is necessary in order to decide on reasonable options. Demolition may be the most favourable option if toxicity is too high. The reuse of extracted material could also be a design principle. To realize this, however, extra labour time is required to extract reusable material carefully and to find ways to store it properly for the intermediate period. The reuse of material adds quality to renovation and makes it incomparable to standard buildings. For the described building, the owner and visitors perceive it as an advantage of the building. On the other hand, the careful extraction of material and

reuse demands good preparation, labour time, and good craftsmen. This eventually adds to the costs and overturns the saved material expenses. Good quality craftsmanship, however, reduces cost in the long run (repair, maintenance, quality of detailing).

One example presented here were electrical sockets and the work of electricians. As most of the sockets and switches were reused, no cost was accrued for these technical parts. However, the labour required for mounting these items nearly

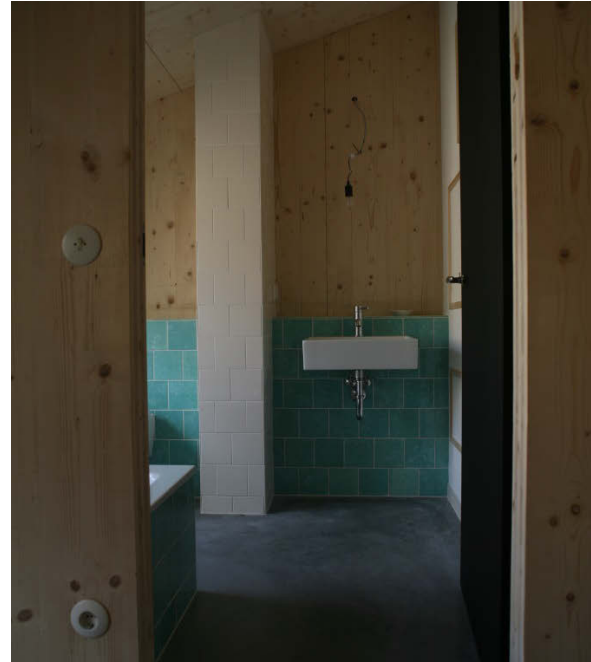

*Fig. 6: view from inside showing material concept.*

doubled as the mounting was more expensive, as two screws were always needed instead of one. The final cost of this part of electric renovation was in the end the same as using new sockets. Figure 6 shows the reuse of tiles (green) in a new context alongside additional tiles (white). Reuse of tiles was possible because of limited breakage due their thickness and careful extraction. Wood used as construction material can be reused after demolition as CLT parts for floors and still have a reasonable size and complete disassembly is possible. This can be achieved by unscrewing building parts, extracting cellulose insulation, removing floor screed, and sound protection. Only when reuse is not possible should energy recovery be an option. For the case study building, current construction drawings of building parts exist (as built) in addition a material list that are helpful for end-of-life considerations.

## 5 DISCUSSION

Overall results for the case study can be outlined as follows: From a design perspective, reuse is an interesting issue and could help to showcase

individuality of projects. Reuse of building material needs sensitive craftsmen with interest in that sort of work. Only a small selection of building parts could be reused on an economically efficient basis.

Reuse of buildings always maintains the existing load bearing structure. Amendments needed to be realized for additional loft conversion in compliance with fire regulations and sound protection. In considering renovation as an option, required standards mandate critical assessment.

The issue of grey energy and resource efficiency preservation is the most adventurous procedure.

“Re-building” requires extra examination and discussion from the architectural side. It demands a higher planning effort. On the other hand, exactly this effort is a creativity engine in terms of design solutions that would not have been considered without the building stock. Material discussions could be an interesting issue to create individual solutions that, on the environmental side, incorporate end-of-life options into the design process.

## 6 CONCLUSION

The documentation of the case study showed an environmentally friendly renovation of an existing building with energetic upgrading to overcome obsolescence. A precise investigation of the building, which included investigations on pollutant content of material, was necessary. This emission control adds strongly to the cost. The reuse of building materials was possible for wooden flooring, tiles, sockets, switches, staircases, and internal doors. The environmental advantage of reused material was not accompanied by economic advantages. Rethinking construction detailing can help to optimize the construction. From this case study general results are transferable to other cases with a focus on reuse:

- Exact investigations on the existing structure, material qualities, and pollutant content in building constructions is necessary.
  - Additional costs through reuse of building material in terms of disassembly and labour time are incurred. Here, environmental advantages still outweigh economic advantages.
  - Building process on site and positive input and willingness from craftsmen are necessary to achieve good results.
- Construction details need to be discussed in the light of reduction of layers under compliance with building codes.

Generally, the focus of new construction needs to be on easy disassembly, sorted parting, and high reusability or recyclability. It is important to avoid material with pollutant content. In this case, this was achieved through timber walls and roof. To use these parameters as design principals is not new [6], but there are only few examples in literature which describe the entire implementation process. The described case study is one of them.

Resource efficiency in building sector needs to also focus on the reuse and renovation of buildings. As the existing building stock has already carries environmental burdens, demolition and rebuilding must only be an option when pollutant content is too high or reuse is impossible. To overcome obsolescence of buildings the renovation is a second chance for the building stock which contributes to reduced mass flow as only part of the material needs to be demolished. In case of new buildings resource efficiency on material side must include demolition of the old building, thereby accounting for mass flow for both demolition and new building.

## 7 REFERENCES

1. EN 15978: Sustainability of construction works – Assessment of environmental performance of buildings – Calculation methods
2. VDI-Richtlinie: 4800, Blatt 1: Ressourceneffizienz, Methodische Grundlagen, Prinzipien und Strategien
3. European Commission: Roadmap to a Resource Efficient Europe, 2011. Communication from the commission to the European parliament, the council, the European economic and social committee of the regions. <http://eur-lex.europa.eu/LexUriServ/LexUriServ.do?uri=COM:2011:0571:FIN:EN:PDF>.
4. Kiel, F., Der Einfluss von Sanierung /Abriss und Neubau auf die Ökobilanz am Beispiel eines Mehrfamilienhauses. 2013, München. Germany: master thesis
5. [www.bnb-nachhaltigesbauen.de](http://www.bnb-nachhaltigesbauen.de)
6. Hassler, U., Langfriststabilität - Towards a Sustainable Development of the Built Environment. 2011. Institut für Denkmalpflege und Bauforschung: Zürich



## Expanding Boundaries: Systems Thinking for the Built Environment

### RESOURCES IN BUILDINGS AND THEIR RECYCLING OPTIONS

K. Krause<sup>1\*</sup>, A. Hafner<sup>1</sup>, S. Schäfer<sup>1</sup>

<sup>1</sup> Ruhr-University Bochum, Universitätsstraße 150 44801 Bochum, Germany

\*Corresponding author; e-mail: karina.krause@rub.de

#### Abstract

In this paper, the material quantities generated from real existing buildings are presented. Location-based information about resources and recycling materials and their potential stock can help to develop concepts for recycling industry to maximize economic benefits and minimize environmental impact. Based on a literature research, the current recycling possibilities of different material groups are pictured. Issues and challenges in the use of recycling materials are also addressed. With the bottom-up analysis of a sample region, a more accurate statement about the material in the building stock is introduced.

#### Keywords:

resource efficiency, implemented materials, quality recycling, demolition waste

## 1 INTRODUCTION

The construction industry is one of the most resource-intensive industries worldwide. 550 m tonnes of mineral materials are installed in Germany, which corresponds to 85 percent of the total domestic extraction.

Therefore, the construction industry plays a key role in the implementation of resource efficiency. If it is possible to make the implemented resource available and to keep the materials in the circular flow, the consumption of resources can be reduced. But there is a lack of reliable data and information of resource and material implemented in buildings and recycling of building materials.

## 2 CONSTRUCTION WASTE IN GERMANY

### 2.1 Waste accumulation and recycling rate

During the deconstruction of buildings significant masses of material are released. The main category are stones, earth and excavated material. Also relevant aspects are the mineral waste from concrete and masonry plus steel from steel reinforcement and steel girder. Approximately 200 m tonnes of construction waste are accumulated per year through the construction, reconstruction and deconstruction of buildings. That is over 50% from the total waste accumulation in Germany in 2012 [1]. This percentage was in recent years at a similar level (s. fig. 1).

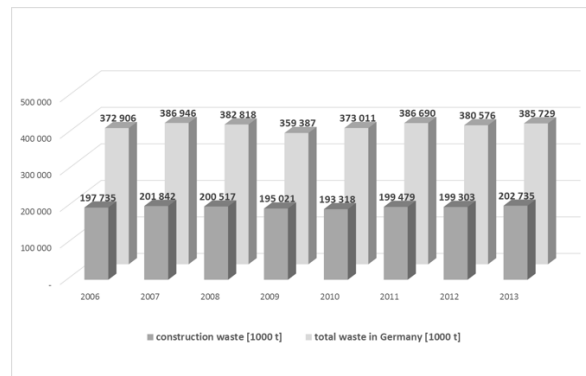

Fig. 1: waste balance in Germany [1].

The 200 m tonnes of construction waste split in 110 million tonnes earth and stones, 52 m tonnes mineral waste and 18 m tonnes road demolition waste.

20 m tonnes of the construction waste have been disposed of. This means that nearly 90% of construction waste was recycled in 2012. This recycling rate includes material recycling and thermal recycling. Main recycling options are road constructions and ground work.

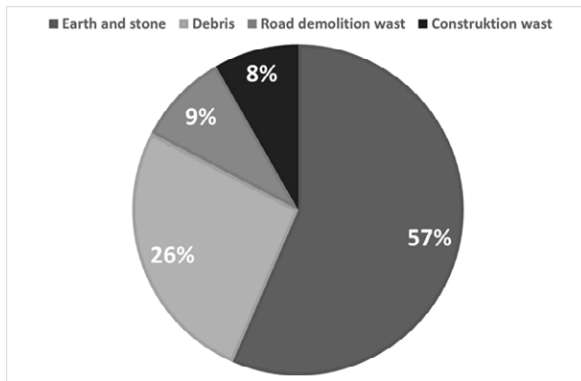

Fig. 2: categories of construction waste 2012 [1].

## 2.2 Recycling options of building construction material

The end-of-life options for construction and demolition waste are generally preparation for reuse, material recycling, energy recovery, or filling the landfill. At the recycling facility, there are differences in terms of quality. The level of recycling is divided into three stages; down cycling, recycling and upcycling.

Furthermore, the disposal options, in particular the recycling of selected waste fractions, are briefly explained.

### Mineral construction waste

In the mineral rubble, it is useful to separate as much as possible from each other, in order to remove possible contaminants in advance like crushed concrete, ceramics, tiles and masonry rubble.

The processing technology determines the quality of the recycling potential. The possibilities for recycling of concrete fractions depend on the structural and environmental requirements in the related application. Possible fields of application are the road construction, earthworks, the production of asphalt and concrete with recycled aggregate and other utilization. Road construction is the most widely used recovery path with more than 50% [2].

Demolition of brick originates from walls and roof tiles. Provided that the bricks can be mechanically cleaned of plaster and mortar residues, it is generally possible to reuse them as a whole. Otherwise broken brick is used as an aggregate for mortars, plasters, sand-lime bricks or as a natural bulk and substructure material for road construction. In addition, recycled bricks may be used as a lightweight aggregate in concrete or as an aggregate in tennis sand [3].

### Timber

Direct reuse of untreated waste wood as beams, formwork material or wooden paving is in principle possible.

Less than a quarter of the resulting waste wood is recycled for the production of laminated wood mouldings and chipboard. The vast majority will be

incinerated in biogas plants and private households for energy recovery [3]. The small percentage of recycled material is partly due to the treatment and coating of wood with wood preservatives, for example, PCP.

### Glass

In general, the majority of waste glass is melted on as often as desired and used for the manufacture of new glass products [3].

Insulating materials made of glass wool are made of recycled glass up to a limit of 70% and are melted with other ingredients. From waste glass foam glass (plates) can be produced for insulation. Furthermore, expanded glass granulate, which can consist of up to 95% recycled glass, is used as a lightweight aggregate for mineral plasters or lightweight concrete, as well as bulk insulation and sound absorbers [4].

However, these material recycling options can cause an interruption in the glass material cycle due to limited means of disposal of the new insulating materials.

### Polyvinyl chlorid

Especially polyvinyl chloride (PVC) is widely used in construction as plastic window frames, pipes, cable insulation, flooring and roofing membranes. For the recycling of PVC windows, doors and roller blinds Rewindo GmbH has built a nationwide collection and transport system in Germany [5]. The mostly non-existent purity of PVC composite materials is a problem for recycling.

### Metal

Structural steel from steel beams, sheets, tubes and rebar have a nearly closed cycle of materials of 99%. 11% of it can be reused directly. This direct re-use avoids re-melting, thus saving energy. The remaining portion is melted down as scrap steel primarily in electric arc furnace and then recycled in high quality new secondary building materials [6].

Copper is also widely used in the building industry. Around 26% of the copper can be found in the construction sector in pipes of plumbing and heating systems, in alloys and claddings. Copper can be recycled any number of times [7].

### Insulating material

The significant proportion of these materials is mineral wool, in particular glass wool and rock wool, and rigid foam insulation made of expanded polystyrene (EPS) for thermal insulation composite system [8][9].

The annual amount of waste of mineral wool products is estimated at approximately 100,000 tonnes. The majority consists of old carcinogenic KMF. Although a higher recycling rate of new KMF is generally possible, currently the majority is landfilled, as described below [8]. Unpolluted rock wool waste can be recycled [10].

Expanded polystyrene (EPS) is composed of approximately 98% air, 2% polystyrene and belongs to the group of foamed plastics [11]. The problem with the recycling of EPS is partly due to the transport cost which arise due to the low bulk density of the EPSs and the lack of economic efficiency of existing treatment processes. Further difficulties arise from the frequent processing of EPS in thermal insulation systems and the use of flame retardants compounds. In this way, the clean separation is made more difficult. Therefore, the main part of the EPS-waste is incinerated. Only small amounts are processed as grist for equalizing screeds, Poroton brick or polystyrol recycle for injection moulding [12].

#### *Material made of gypsum*

Gypsum is used due to its good processability and its low-energy production, in the construction industry as plaster, dry screed, or as plasterboard in interior design. Theoretically, any gypsum can be recycled many times, because the starting material is chemically identical to the hardened end product. For a practical application the plaster must be sorted, which is hardly to be found, because the plaster is usually a part of the overall construction waste [3].

Possibilities of separation and treatment processes for gypsum waste are described in [13] and [14].

### 3 RESOURCES IN BUILDINGS

#### 3.1 Building stock in Germany

For a forward-looking material process management of materials in the construction it is necessary to have information of the existing material and its quantities. In Gruhler et al. [15], a building material calculation program was developed, which calculates the housing stock and documents material and energy characteristics of building types. There are ten multi-family houses (MFH) built between 1880-1990 and eight single-family homes (SFH) built between 1960-1990. The types of buildings have been selected, so that these reflect the totality of the existing building stock in Germany. System boundary is the outer dimensions of the building, extensions (balconies) are not considered. Basement are included in the calculation.

Here concrete and bricks are summarized as mineral materials. The existing storage in building is described in the material intensity. The material intensity is defined as the quotient of the material warehouse and a typical building area or a typical building volume. For the results shown here, the gross external area (GEA) according to German DIN 277-1 is selected as a typical building area. Figure 3 shows the material intensity of different MFH and SFH in t/m<sup>2</sup> GEA. Gruhler et al. comes to the following conclusions: MFH have a material

intensity in t/m<sup>2</sup> main usable area (MUA) of average 2,2 t/m<sup>2</sup> MUA, the traditional types of buildings are always more intense than the industrially erected. SFH have an average of 2.8 t/m<sup>2</sup> MUA a 0.6 t/m<sup>2</sup> MUA (27%) higher material intensity as MFH SFH are more material intensive than double or detached SFH. The number of floors, has a large influence on the material intensity in MFH [15].

#### 3.2 Material intensity in new buildings

Own calculations are based on real-built buildings. They have been carried out on the basis of design drawings and mass calculations. This bill of quantities is also the basis for the performance of life cycle assessment (LCA) of the buildings. In LCA the materials are studied for their effect on the environment. In this study the mass investigations are used to make a statement about the included resources in buildings.

The studied buildings are SFH and MFH. The SFH have a maximum of three storeys. In the MFH, number of floors vary between three and eight. The construction type's massive wood construction, timber frame, conventional (reinforced concrete, EIFS, brick) and hybrid constructions were calculated. Hybrid structure is understood as a combination of mineral load bearing structure and wooden facade.

The year of construction of the buildings is maximum of five years back, so all have a high energy standard. The system boundary of the investigations are the floors above ground. Basements, balconies and outdoor facilities were not taken into account. Altogether we calculated 16 SFH (8 wooden, 8 mineral buildings), and 27 MFH (6 wooden, 13 hybrid and 8 mineral buildings).

Figure 4 shows the amounts of materials in SFH houses per m<sup>2</sup>/GEA. The largest share is the mineral fraction. Even buildings, where the primary structure is made of wood, show a high proportion of mineral materials although no basement is included. The comparison of the masses of SFH shows in buildings of conventional design twice as much mineral material as in wooden structures. Wooden structures contain twice as much of renewable materials. The same results show calculations of MFH. On average, new mineral buildings (MFH and SFH) show a material intensity of 1.2 t/m<sup>2</sup> GEA.

Wooden buildings have a lower material intensity of 0.6 t/m<sup>2</sup> GEA for SFH and 0.8 t/m<sup>2</sup> GEA in MFH. Hybrid constructions have a value of 1.0 t/m<sup>2</sup> GEA. The results show that the quantities and composition of material is critically dependent on the construction.

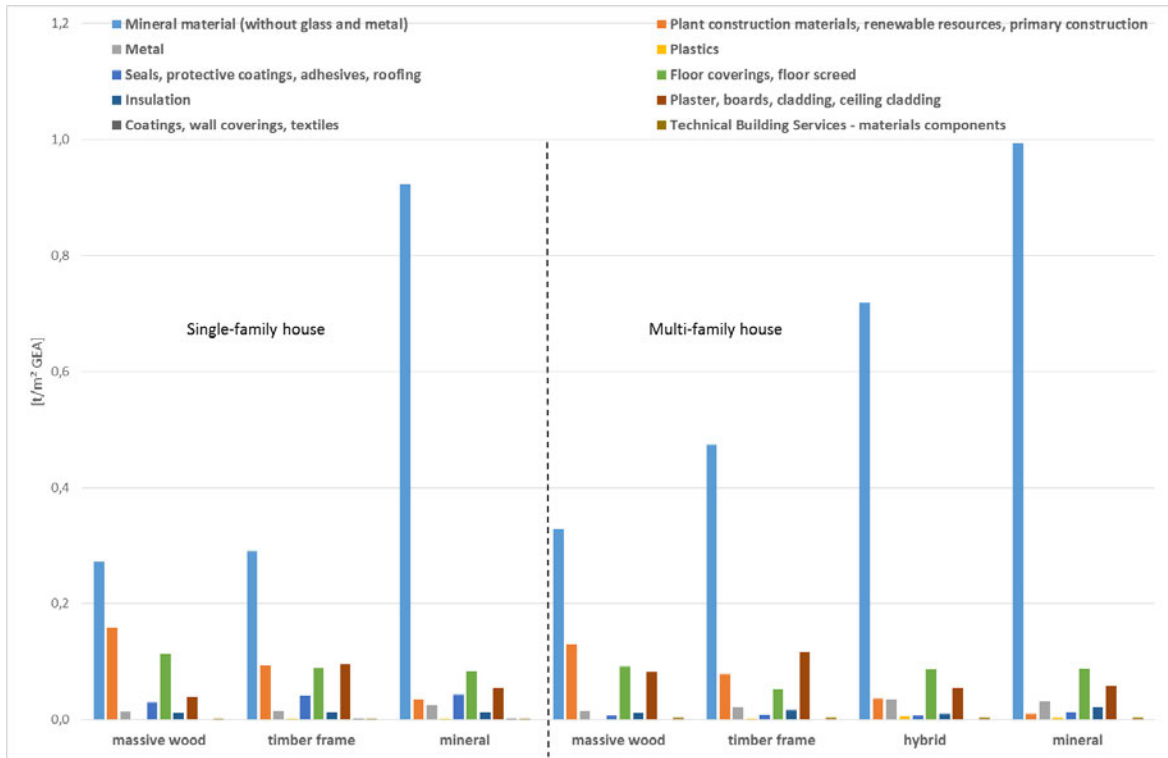

Fig. 3: mass of resource in buildings. Adapted after [15].

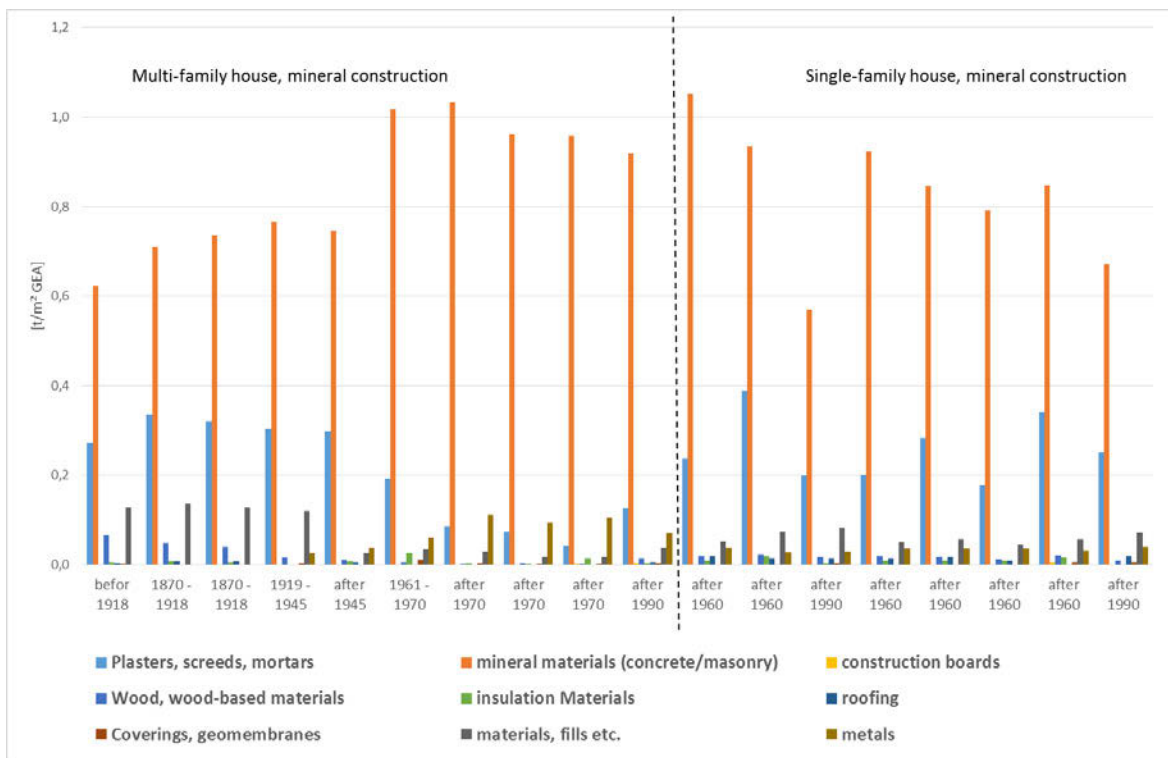

Fig. 4: average mass of material in SFH and MFH.

### 3.3 Material quantities of a new residential quarter

The city of Munich is currently planning a new residential quarter on a former military conversion site with 1800 units and a floor area of approximately 254.000 m<sup>2</sup>. The goal is to develop strongly needed affordable housing and at the same time to address issues of energy efficiency and environmental impact with innovative approaches. The development plan for the new quarter is shown in figure 5 and shows a wide variety of buildings. The southern part of the quarter will be designed as an „Eco-City“. In this part – outlined by the red line - around 500 flats are to be built. Framework for the „Eco-City“ is innovative energy supply with renewable energies, buildings in plus-energy-standard and building with wood, a mobility concept and shared facilities. The „Eco-City“ contains small terraced houses, free standing four story-buildings and 5-7 multi-story residential buildings.



Fig. 5: new residential quarter in Munich [16].

It is assumed the entire northern part will be erected in a conventional mineral design.

In the part of the “Eco-City” 25% of floor area is assumed to massive timber constructions and 43% in timber frame construction. 32% of floor area is expected to be realized in a hybrid construction, which has been accepted here.

From the calculated values (s. fig 4) average values are made for the construction types massive wood, timber frame and conventional-mineral. Hybrid structures will be considered in the MFH additionally. The calculated buildings can be classified to the planned buildings types. The SFH meet the small terraced houses with a maximum number of 3 floors. The MFH meet free standing four story-buildings and 5-7 multi-story residential buildings.

By assigning the calculated average values of real buildings to the planned building development in floors and GEA the expected material stock of the new residential quarter can be determined. In

figure 6 the calculated material quantities in tonnes for the investigated area are shown.

An area of 30 hector (subdivided in approx. 53.000 m<sup>2</sup> floor area of wooden construction and 201.000 m<sup>2</sup> floor area of mineral construction) with the building typologies described above includes approximately 200,000 tonnes of material resources.

The result shows the proportion of predominantly mineral material. Despite an increased proportion of wooden buildings as usual, the mineral materials dominate. The mineral materials have a 80% share of the total material usage.

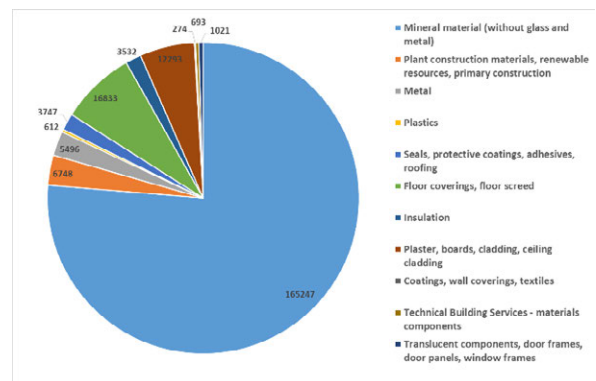

Fig. 6: mass of resource of a new residential quarter in tonnes.

### 3.4 DISCUSSION

The presentation of results of existing buildings from own LCA calculation and transmission on new planned buildings shows that a unified planning tool for material documentation is useful.

The calculations also show a material intensity of 0.9 t/m<sup>2</sup> GEA for SFH and 1.0 t/m<sup>2</sup> GEA for MFH of mineral material in mineral constructions (s. fig. 4). Investigations by [15] show a material intensity of 0.6 t/m<sup>2</sup> GEA for SFH and 0.9 t/m<sup>2</sup> GEA for MFH by consideration mineral materials of buildings after 1990 (s. fig. 3). The comparison of the own mineral material quantity calculation and quoted literature values indicate a comparable level. The differences may be caused by variations in the considered elements or in the definition of material categories. Future arrangements for system boundaries should be developed for a consistent documentation of materials. Depending on the material type and construction type material intensity varied. The choice of reference area is crucial for the assessment of buildings. It offers different interpretations [15].

## 4 SUMMARY

It could be shown that the building industry is one of the most resource-intensive industries, but also high rates of recovery or recycling are realised. They are available for almost all materials of the demolition in building. Quality recycling is complicated for complex materials, inseparable

materials and critical compounds or it is even entirely prevented. To facilitate future technical conditions for an efficient and high-quality use of materials, data on the size and composition of the existing anthropogenic raw material storage are required. Investigations by [15] for the existing material storage in buildings were shown.

Based on own LCA calculations, possible material stock of new buildings was calculated, and extrapolated for a planned housing estate. It has been shown that the choice of construction material has an influence on the material intensity. Wooden buildings have lower material intensity than conventional constructions. But the proportion of renewable materials is twice as large compared to mineral material construction. This has a big influence in the consideration of energy efficiency and environmental impacts. The exact values of environmental impact will become even more evaluated.

## 5 REFERENCES

1. Statistisches Bundesamt, [www.destatis.de](http://www.destatis.de) Retrieved 20.04.2016.
2. Bundesverband Baustoffe – Steine und Erden e.V. (Hrsg.): Mineralische Bauabfälle – Monitoring 2010. Berlin: Kreislaufwirtschaft Bau, 2013
3. Krauß, O.; Werner T.: Kurzanalyse Nr. 8: Potenziale eines hochwertigen Recyclings im Baubereich. Berlin: VDI Zentrum Ressourceneffizienz GmbH (VDI ZRE), 2014
4. Korb, N. (Hrsg.): Glaswolle – Ökobilanz. URL: <http://nachhaltiges-bauen.de/baustoffe/Glaswolle>. Retrieved 20.04.2016.
5. Rewindo GmbH: So gelangen Ihre alten Fenster ins Recycling. URL: <http://www.rewindo.de/rewindo-recycling-service/index.html>. Retrieved 20.04.2016.
6. Fischer D.; Hauke, B.: Umwelt-Produktdeklaration Baustähle Erläuterungen. Düsseldorf: Bauforumstahl e.V.(Hrsg.), 2010
7. Dorner U.: DERA Rohstoffinformationen - Rohstoffrisikobewertung – Kupfer. Berlin: Deutsche Rohstoffagentur (DERA) in der Bundesanstalt für Geowissenschaften und Rohstoffe (BGR), 2013
8. Bundesinstitut für Bau-, Stadt- und Raumforschung (Hrsg.): Künstliche Mineralfaserdämmstoffe. Bonn, 2011
9. Statista GmbH: Struktur der Wärmedämmverbundsysteme in Deutschland nach Dämmstoffart im Jahr 2013. 2014. Quelle: Fachverband Wärmedämm-Verbundsysteme
10. DEUTSCHE ROCKWOOL Mineralwoll GmbH & Co. OHG: Nachhaltigkeit. URL: <http://www.rockwool.de/d%C3%A4mmstoff+steinwolle/nachhaltigkeit#click.tabs.4>. Retrieved 22.04.2016.
11. Korb, N. (Hrsg.): Polystyrol EPS – Ökobilanz. URL: <http://nachhaltiges-bauen.de/baustoffe/Polystyrol%20EPS>. Retrieved 22.04.2016.
12. Fraunhofer-Institut für Verfahrenstechnik und Verpackung IVV: EPS-Loop - Recycling von EPS-Abfall zu re-expandierbarem Polystyrol. URL: <http://www.ivv.fraunhofer.de/de/geschaeftsfelder/kunststoff-rezyklate/recycling-eps-abfall.html>. Retrieved 22.01.2016.
13. Müller, A.: Bauschutt ohne Gips. In: Steinbruch und Sandgrube, S.40-45, 11/2012
14. Meier, R. H.: Gipsrecycling senkt Abfallkosten. In: Applica, S. 14-16, 2007
15. Gruhler, K. et al., Stofflich-energetische Gebäudesteckbriefe – Gebäude- vergleiche und Hochrechnungen für Bebauungsstrukturen, Institut für ökologische Raumentwicklung e.V., Band 38, Dresden, 2002
16. Stadt München, <http://www.muenchen.de/rathaus/Stadtverwaltung/Referat-fuer-Stadtplanung-und-Bauordnung/Stadt-und-Bebauungsplanung/Stadtplanung-Ost.html>. Retrieved 25.04.2016





## Expanding Boundaries: Systems Thinking for the Built Environment

### LIFE CYCLE GHG EMISSIONS FROM A WOODEN LOAD-BEARING ALTERNATIVE FOR A ZEB OFFICE CONCEPT

A. Houlihan Wiberg<sup>1</sup>, T. Barnes Hofmeister<sup>1,2</sup>, T. Kristjansdottir<sup>2</sup>, B. Time<sup>2</sup>

<sup>1</sup> Zero Emission Building Research Centre (ZEB), The Faculty of Architecture and Fine Art, Norwegian University of Science and Technology (NTNU), N-7491 Trondheim, Norway

<sup>2</sup> SINTEF Building and Infrastructure, Høgskoleringen 7b, N-7465 Trondheim, Norway

\*Corresponding author; e-mail: aoife.houlihan.wiberg@ntnu.no

#### Abstract

A major contributor to global greenhouse gas emissions is the production of concrete and steel for the construction industry IPCC (2007). To combat global warming, innovative solutions are needed in the construction industry to reduce emissions from both energy and material use in buildings. In a previous study the first phase of a GHG emissions analysis for a Norwegian ZEB office concept was presented. The aim of which was to achieve a zero emission balance where operational and material emissions are accounted for ZEB OM. The results from the first phase showed that the load bearing system accounted for a large share of the embodied emissions. In addition, the ZEB OM ambition level was not met, thus emphasizing the need for further work on alternative solutions and material choices.

This paper presents the results of a comparative study between this original office concept study and a predominantly wooden alternative loadbearing structure consisting of wood trusses, glue laminated beams and columns. The wooden alternative is comparable since it has been dimensioned to fulfil the same technical requirements for bearing capacity, sound and fire resistance. In addition, the system boundary was extended to include three alternative end-of-life scenarios. It was found that the wooden alternative structure almost halved the emissions compared to the original concrete and steel ZEB office concept model. This trend is the same in the cradle to gate and all three end-of life scenario's. The analysis clearly shows that emissions from the production process outweigh any emissions from the material's end-of-life treatment. This means that the material choice plays a major role in embodied emissions, as well as it being crucial to reduce the required construction material quantity.

#### Keywords:

Embodied emissions; materials; ZEB

### 1 INTRODUCTION AND BACKGROUND

The results from the office concept study showed that material emissions accounted for a large share of the total emissions. Also, the results showed that the emissions from the load bearing structures were a large contributor. The ambition level ZEB-OM was not met, thus emphasizing the need for alternative options and material choices.

This study looks at material emissions from the original ZEB office concept and compares it with emissions from an alternative wooden load

bearing structure. Furthermore, the study includes three end-of-life emission scenarios for the load-bearing alternatives. The first scenario calculates end-of-life emissions based on end-of-life treatment data from Ecoinvent Version 2.2 [1]. The second scenario looks at the effects of incineration of used construction wood in a municipal incineration plant, and the third scenario is based on information from the Norwegian recycling industry. The wooden alternative has been dimensioned by

Hammersland [2]. The full details of this study can be found in Barnes Hofmeister et al. [3].

## 2 METHOD

The overall method is to document greenhouse gas emissions due to the material use in a wooden load bearing system suitable for an office building. An attributional life cycle carbon dioxide emission analysis is applied. The life cycle assessment methodology is described in Dokka et al. [4].

### 2.1 Goal and scope

The goal of this analysis is to calculate the embodied GHG emissions for a wooden load bearing alternative for a zero emission office building concept for the production stage (A1-3). Fig. 1 shows the life cycle stages considered in the initial concept study (dotted black box) and the expanded boundaries for this study (dotted red box). The service lifetimes are assumed to be 60 years for both the bearing system based on the initial assumption in Dokka et al. [4].

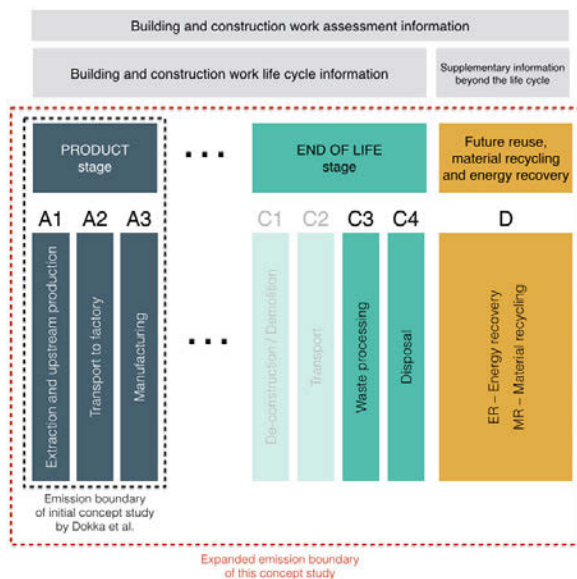

Fig. 1: System boundaries in initial study [4] and the extended boundaries used in this study (illustration based on EN 15978).

### 2.2 Case building

The building, Fig. 2, is a typical Norwegian four story office building with additional underground parking facilities. The heated floor area is 1980 m<sup>2</sup>. The basic design is based on the current Norwegian building codes TEK 10 [5], but the energy concept is based on the Norwegian passive house standard [6] and the building is estimated to have a service life time of 60 years. The model is designed for Oslo climate. Detailed descriptions of the building physics and energy concepts can be studied in Dokka et al. [4].

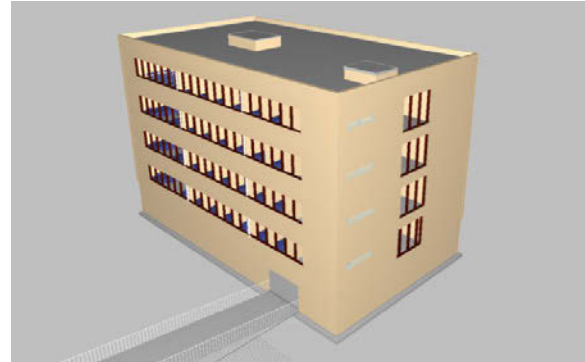

Fig. 2: Revit Model [4].

### 2.3 Construction alternatives

Hammersland [2] takes the original ZEB Office concept model and dimensions major parts of the loadbearing structure with wood trusses and glue-laminated beams and columns. This work includes details on the load analysis to make a realistic design with the same performance criteria and room program as the base case. The wooden alternative, however, maintains concrete and steel in reduced quantities for the foundation works and technical shafts within the structure. Neither the reference structure nor the wood case has been optimized from a statics perspective.

#### Base Case: Concrete and steel load bearing structure

The load-bearing structure follows a very traditional approach using concrete slabs supported by steel beams and columns. The building envelope is placed on the outside of this load-bearing skeleton. The basement and foundations are both made of reinforced concrete. The slabs are hollow core elements. The load-bearing element in the original floor is 200 mm reinforced concrete with a 30 mm concrete finish.

#### Wood Case: Wood load bearing structure

The altered loadbearing structure consists of wood trusses resting on glue-laminated beams and columns. The flooring material itself consists of oriented strand boards (OSB) covering the truss construction, creating a continuous surface (Fig. 3). For structural reasons the elevator shaft, the staircase and the ceiling over the meeting room, as well as, the basement (walls, columns, floor and ceiling) are kept as concrete components. However, the foundations are reduced in size since the wooden structure is lighter than the traditional concrete and steel one. In order to take wind loads a steel cross is implemented in the east façade of the building.

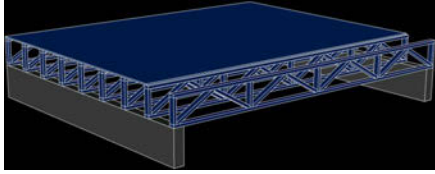

Fig. 3: Revit Model [4].

The wooden alternative is a timber structured floor, where the structural element is a wooden truss. In the ceiling there are two gypsum boards, giving the structure sufficient protection during a fire. Due to the issues of sound spreading through wood sound, impact plates are added underneath and overtop the truss-OSB chip-board ceiling. Sound impact plates are typically made from mixed cell polyurethane foam, while the product *Silencio*, also intended to mitigate sound penetration, is made of wood fibre. The truss will be prefabricated, allowing an efficient building process.

## 2.4 Inventory

Emission data from Ecoinvent was chosen since it was used in the original ZEB office concept model. Also based on the study by Barnes Hofmeister and Thorkildsen [7] the Ecoinvent proved to be the most comprehensive data source, offering information for all required materials. The load-bearing structure of the original is only composed of four materials whereas the wooden alternative consists of nine different materials. The complete inventories for both alternatives are given in Table 1. The material quantities for the concrete and steel load-bearing structure of the base case are based on Dokka et al. [4]. In the wood case all major components are taken from Hammersland [2]. However, since Hammersland's work did not go into detail concerning the floor/ceiling build up, material quantities for gypsum plaster boards, sound impact plates and wood fibreboards are derived from information provided by the wood truss producer. Concrete is the major construction material in both cases. This is due to maintaining a concrete basement and foundations also in the wooden construction alternative. Additionally, the wood case uses a larger material variety. All emission factors are converted to  $\text{kgCO}_2/\text{m}^3$  with the respective densities provided by Ecoinvent (Table 2).

Material	Base Case [m <sup>3</sup> ]	Wood Case [m <sup>3</sup> ]
Structural timber	0	70
Glulam beams/columns	0	19
Chip boards	0	43
Nail plates	0	0,2
Steel studs	0,3	0
Gypsum plaster boards	32	65
Sound impact plates	0	44
Silencio (wood fibreboard)	0	19
Reinforcing steel	19	5
Concrete foundation	104	33
Concrete inner load-bearing walls	134	134
Concrete in columns	3	3
Concrete in slab structures	524	125
Concrete in outer walls	109	109
Concrete total	874	408
<b>TOTAL</b>	<b>925</b>	<b>673</b>

Table 1: Overview of material quantities for both construction alternatives.

Material	Emissions (kg CO <sub>2</sub> /m <sup>3</sup> )	Reference
Structural timber	104	Sawn timber, softwood, planed, kiln dried at plant/ RER U
Glulam beams/columns	205	Glued laminated timber indoor use, at plant/ RER U
Chip boards	312	Oriented Strand Board, at plant/ RER U
Nail plates / steel studs	27554	Steel, low-alloyed, at plant/ RER U + steel product manufacturing, average metal working /RER U
Gypsum plaster boards	274	Gypsum plaster board, at plant/ CH U
Sound impact plates	129	Polyurethane, rigid foam, at plant/ RER U
Wood fibre board	56	Fiber board soft, at plant (u=7%)/CH U
Reinforcing steel	11383	Reinforcing steel, at plant/RER U
Concrete	261	Concrete, normal, at plant/ CH U

Table 2: Overview of extracted product stage emission factors.

## 2.5 Waste Scenario's

In order to gain understanding of the environmental impact of the various end-of-life treatments three scenarios are investigated.

Generic Ecoinvent:	This scenario follows the recommended end-of-life treatment for building materials described in table 3.18 in Part V Building Material Disposal of the report collection affiliated with SimaPro [8]. There will be no energy recovery from waste materials treated with the process of municipal incineration.
Ecoinvent w/ Energy Recovery:	This scenario is congruent with Generic Ecoinvent, but considers energy recovery from municipal incineration.
Norwegian Recycling Contractor:	For a better apprehension of the end-of-life of the building within the Norwegian framework, data has been gathered from a Norwegian recycling contractor regarding typical end-of-life treatments. The provided process descriptions were modelled with SimaPro S 8.0.1 Multiuser Classroom in order to attain emission data. The recovered energy substitutes fossil fuel that leads to factored-in emission savings. For a clear picture of the building material lifetime emissions, product stage emissions were added to the end-of-life emissions.

Table 3: Investigated scenarios.

### 3 RESULTS

Fig. 4 below shows the comparison of the three scenarios. It is apparent that the wooden structure (wood case) causes almost 40% less emissions compared to the original ZEB office concept model (base case) in concrete and steel. This trend is the same in all scenarios.

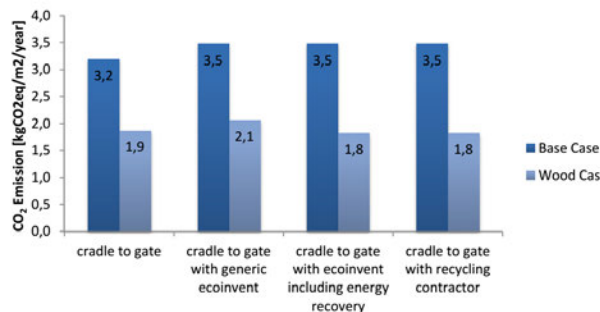

Fig. 4: Three end-of-life scenarios including product stage emissions compared to only cradle-to-gate emissions.

The total emissions (all life cycle stages) for the base case only vary in the third scenario. The reason is that gypsum plasterboards are landfilled instead of recycled, causing a slightly higher impact. For the wood case, however, the emissions fluctuate from scenario to scenario. The scenario based on information from the Norwegian recycling contractor shows the lowest emissions due to larger fossil fuel emissions being substituted with demolition wood (wood replacing fuel oil in private enterprises). The wood products from the scenario 'Ecoinvent with energy recovery' substitute emissions caused by a mixture of fuel oil and natural gas, which are slightly lower than the ones of pure fuel oil.

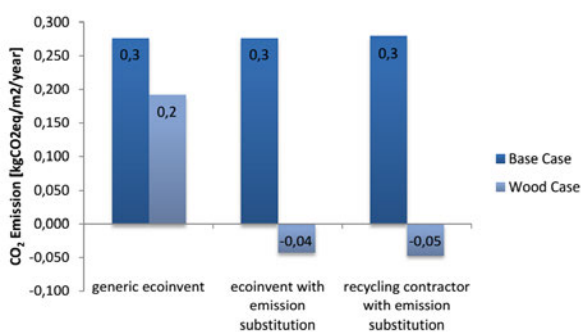

Fig. 5: End-of-life emissions for all three scenarios showing negative emissions in case fossil fuels are substituted with wood.

Fig. 5 shows the overall emissions from all considered life cycle stage. Comparing the data for all three scenarios it becomes obvious that wood as energy carrier substituting fossil fuels leads to negative end-of-life emissions. Despite higher emissions due to landfilling of gypsum plasterboards (four times higher compared to recycling) the Norwegian recycling contractor scenario has the largest emission savings due to demolition wood substituting fuel oil in private

enterprises. Considering that a possible future situation in the Norwegian energy sector might be that demolition wood will not substitute fossil fuels, but rather emissions from heat pumps driven by electricity, the benefits of wood as laid out here may decrease.

Since the emission from the end-of-life stages are in the order of one magnitude smaller than the production stage emissions, it becomes clear how crucial it is to be conservative with respect to the material use in buildings, regardless of whether the structure is made of wood or concrete and steel. Especially concrete and steel have a tremendous impact compared to all other materials. In both models concrete is the strongest emission driver. Although the major environmental impact is caused during the product stages (A1-A3), the end-of-life of concrete causes the major fraction of emissions among all end-of-life processes (C3 and C4).

Combustible materials substituting fossil fuels drive negative emissions as shown in Fig. 5. This will of course only be feasible as long as the back-up fuels in district heating systems are fossil fuels. Overall, the fossil fuel mixture of 1/3 natural gas and 2/3 fuel oil has 18 times (20 times for pure fuel oil) higher emissions than the end-of-life procedure for wooden building materials including municipal incineration. In the case of wood fibreboards, the emissions are almost comparable (0,8 times the emissions of substituted fossil fuel) due to chemical adhesives used to bind the fibres into solid boards.

The assessment, however, also showed that incineration is not preferable in any case. While wood products are favourable to fossil fuels, the sound impact plates used in the wooden constructions, made of polyurethane foam, cause four times higher emissions than the substituted fossil fuel.

### 4 DISCUSSION

Since the original ZEB office model concept was modelled after a typical four-story office building including a basement for parking, the same structure has been used in the alternative wooden load-bearing structure. Due to lower weight the reinforced concrete foundations and basement walls are downsized in the wood case. However, the emission picture is still dominated by the emission of the remaining concrete and steel components. In order to really minimize emission in the wooden construction it should be considered to not assume that there is a basement underneath or to use a different technology (e.g. solid wood based basement, e.g. a combination of concrete, steel and wood).

The study shows that it is crucial to keep product life cycle emission in mind while initially conceptually designing a building, since

upstream alterations, such as replacing a concrete and steel load-bearing structure with a wooden one, might result in only minor benefits. The study also shows that reducing production stage emissions is highly relevant, since even energy recovery in an end-of-life scenario only will result in about a 20% energy yield.

In order to gain a better understanding of the overall building, in the next steps a thorough ZEB-balance should be established going beyond the changes within the load-bearing structure.

In this preliminary study on how different end-of-life processes impact the building emissions, all numerical data has been extracted from EcoInvent. The scenarios itself are intended to reflect current building practice and are therefore based upon information from the building sector rather than scientific sources. Detailed numerical values for the three investigated scenarios can be found in the appendix of Barnes Hofmeister et al. [3]. Especially in the case of the Norwegian recycling contractor, this data might not be accurate enough, since it was only possible to find information about the specific processes, but with no insights into specific emission values. Given that the electricity mix in Norway has a much lower emission factor compared to other parts of Europe the recycling processes will reflect that. In future analyses it would be recommended to find more precise numerical values either from Norwegian processes or via the means of Norwegian EPDs. To this day Norwegian EPDs, however, were insufficient in their data variety to sufficiently model especially the wooden load-bearing structure.

Consideration of the building's lifetime may impact its environmental load. Quantitatively looking at our current built environment, it seems that masonry buildings can last longer than lighter wooden structures. With more scientific insight, an alteration of assumed lifetimes for lighter and heavier buildings might be necessary to better represent their true environmental impact.

## 5 CONCLUSION

Our study indicates that the emissions due to the material use in the wooden alternative are around 40% less than the initial concrete and steel bearing system. This also confirms that compared to the production stage emissions, the end-of-life emissions add less than 10 % to the overall balance (8 % base case, 9 % wood case). At the same time, concrete and steel prove to be the responsible for 75 % of the production stage

emissions even in the building with the wooden load-bearing structure. Most of the concrete and reinforcing steel is utilized in the basement. We have not considered the impacts of thermal mass on the operational energy use of the buildings.

## 6 ACKNOWLEDGEMENTS

This paper is based on a ZEB report 20 within the Research Centre on Zero Emission Buildings. The authors gratefully acknowledge the support from the Research Council of Norway, BNL – Federation of construction industries, Brødrene Dahl, ByBo, DiBK– Norwegian Building Authority, Caverion Norge AS, DuPont, Entra, Forsvarsbygg, Glava, Husbanken, Isola, Multiconsult, NorDan, Norsk Teknologi, Protan, SAPA

## 7 REFERENCES

1. EcoInvent version 2.2., www.ecoinvent.ch
2. Hammersland, P.V. *En nullutslipps konsept-analyse av et kontorbygg Optimalisering av bæresystem i forhold til bundet CO<sub>2</sub>-utslipp*. ZEB Internal report. Trondheim: 2013
3. Barnes Hofmeister, T., Kristjansdottir, T., Time, B., Houlihan Wiberg, A. (2015) *Life Cycle GHG Emissions from a Wooden Load-Bearing Alternative for a ZEB Office Concept*. ZEB Project report 20–2015. ISBN 978-82-536-1440-3
4. Dokka, T. H., HAASE, M., Kristjansdottir, T., Mellegård, S., Time, B., Tønnesen, J. *A zero emission concept analysis of an office building. The Research Centre on Zero Emission Buildings Project Report 8, 2013*, SINTEF Academic Press, Oslo.
5. KR D, Kommunal og regionaldepartementet (2010) Forskrift om tekniske krav til byggverk (Byggteknisk forskrift – TEK10, FOR-2010-03-26-489). Technical Building Regulations (TEK10, FOR-2010-03-26-489, in Norwegian).
6. Standard Norge. (2012) Kriterier for passivhus og lavenergibygninger - Yrkesbygninger (Criteria for passive houses and low energy buildings - Nonresidential buildings) NS 3701:2012.
7. Barnes Hofmeister, G.T., and I. Thorkildsen. *Environmental Comparison of the load-bearing structure in the ZEB Office model concept with a wood based alternative*. Internal project report. Trondheim: NTNU 2014
8. Doka, G. *Building Material Disposal*. EcoInvent report No. 13 part V. Dübendorf: Swiss Center for Life Cycle Inventories, 2007





## Expanding Boundaries: Systems Thinking for the Built Environment

### SMART REGENERATION OF PUBLIC UTILITY BUILDINGS

E. Arbizzani<sup>1\*</sup>, P. Civiero<sup>1\*</sup>, C. Clemente<sup>1\*</sup>

<sup>1</sup> Department of Pianificazione Design Tecnologia dell'Architettura, Sapienza University of Rome, Rome, Italy

\*Corresponding authors; e-mail: eugenio.arbizzani@uniroma1.it,  
paolo.civiero@uniroma1.it, carola.clemente@uniroma1.it

#### Abstract

Energy renovation is instrumental for reaching the EU 2020 goals and smart districts are integral parts for the development of Smart Cities in the near future. At building scale, every structure runs differently and energy consumption profiles depends not only on climatic locations and technological quality of buildings, but also on occupancy levels and different types of public utility buildings (school, healthcare and homes for the elderly, office, university).

A new smart regeneration approach will represent the central focus beyond a simple technological concept of Smart Building, where the buildings should be seen as part of a larger system of energy networks and whose diffusion within the city could be linked with the concept of urban energy network and physical "nodes".

Currently, good practices and projects aim to promote the adoption of the key technology and to identify and remove barriers to deployment. Still today, approaches to record non-residential assets in a comparable structure have not been successfully implemented yet and data are fairly poor.

An integrated approach is proficient to reveal the performance of the innovation, its technical requirement, as well as prerequisite required in terms of existing infrastructures, technical expertise, regulatory requirements and financial costs involved.

An ongoing research from the PDTA Dept. is promoting a set of exemplary of public utility buildings and a portfolio of material, industrialized systems, smart and energy equipment solutions to be used in refurbishment projects, in order to stimulate a whole vision of the smart efficient buildings and different scenarios according to the boundaries of a smart district level in Rome Municipality.

#### Keywords:

Interactive nodes; systemic approach; Building Energy Management Systems; set of technical solutions

## 1 INTRODUCTION

A large number of studies and surveys at the EU level and Eurostat data show that the existing European building stock requires urgent adaptation to current and future needs. More than 40% of the energy consumption in Europe is due to heating, ventilation and air conditioning and lighting operations within buildings. The non-residential building sector is characterized by a large number of different building types, each with specific functional, morphological and structural characteristics and parameters. In addition, the buildings differ on account of their

age, the construction materials used in the corresponding periods and their technical equipment.

In the recent past some approaches have been made to reflect the current situation in terms of available information, but also in terms of finding appropriate ways to structure a non-residential building typology. Due to the poor availability of data so far, there is a great need for further research. Therefore, understanding energy use in the non-residential sector is complex as end-uses such as heating, ventilation, cooling, lighting, IT equipment and appliances vary greatly from one

building category to another. Utility buildings, according to existing building and construction standards, have to be partly renovated (building envelope, HVAC) approximately every 20 years, and completely retrofitted approximately every 35 years [1]. A large portion of the existing utility building stock in the EU was built after the Second WW and mainly during the 60-ies and 70-ies. The renewal of this stock to meet energy standards and face climate issues – based on more efficient processes and zero or nearly zero emission – represents the next perspective for cities [2]. A sensible management of energy in these buildings can achieve major savings in the energy use (and thus, also cost) and in the reduction of greenhouse emissions.

Nowadays this is no more a vision but a concrete challenge for governments, associations, stakeholders and policy makers at all levels, and represents currently a priority for G20, World Bank and OECD agenda. According to the EPBD (Directive 2010/31/EU), all new buildings shall be nearly zero-energy buildings by the 31<sup>st</sup> of December 2020, and 2 years earlier for buildings occupied and owned by public authorities. Public authorities should set the example by renovating each year 3 % of central government buildings with insufficient energy performances, as required by the Energy Efficiency Directive (EED, 2012/27/EU). This requirement is complemented by the EED obligation for Member States to put in place longer-term renovation strategies. The implementation of the EPBD is supported by a set of European standards, dealing with the thermal performance of buildings and building components, ventilation, light and lighting, heating systems, building automation, controls and building management.

Buildings could be transformed from purely demand driven electricity consumers to interactive partners with a potential to store thermal energy [3]. The concepts of the Smart City and Smart Grid provide one of the possible solutions that could make historic, consolidated cities more efficient and sustainable, encouraging reflection, ideas, research and projects to regenerate this kind of environment with a focus on smart services [4]. A multi technology perspective, combined with energy management, will make existing energy systems of urban areas more intelligent, where decentralized energy generations and highly interconnected urban infrastructures are in place, buildings become physical interactive nodes of a larger Smart Grid which calls for an upgrade of building models in the direction of Smart Buildings, for a transition from single buildings to Smart Objects [5].

## 2 METHOD

The goal of this ongoing study is to design a roadmap for the retrofit of the existing public utility building stock, through the analysis of case studies of major significance in terms of building characteristics and period of construction.

According to the World Energy Outlook 2015 this study puts itself forward as a methodological approach to the widespread problems of saving energy, in which the construction sector is a fundamental element. Furthermore, Smart Cities and Communities Initiative highlights the importance of intelligent energy management systems in cities in order to achieve massive reductions of greenhouse gas emissions by 2020, and the integration of renewable energy sources as outlined in the 20-20-20 targets and in the European Energy Roadmap 2050 [6]. The Energy Roadmap 2050 considers that the high “energy efficiency potential in new and existing buildings is key” to reach a sustainable energy future in the EU, contributing significantly to the reduction of energy demand, the security of energy supply and the increase of competitiveness [7]. The Roadmap to a Resource Efficient Europe identifies the buildings among the three key sectors responsible for 70% to 80% of all environmental impacts [8]. In 2011 a survey on buildings' gross floor space in the EU27 revealed that this floor space totals approximately 30,500 sq km. 25% of this floor space are made up by non-residential buildings of which 28% consist of retail buildings, 23% of offices (the largest part are public buildings) and 28% are pure public buildings such as schools 17%, hospitals 7% and sports facilities 4%. The majority of these buildings are not owned by the national governments but by local authorities such as cities, urban communities, Lander, provinces, regions and others. When a Private property represents the ownership entity, usually these local authorities provide a subvention for their construction and maintenance [9]. The development and use of intelligent solutions based on ICT could promote efficiency, connectivity and the integration of urban infrastructures and systems at two distinct levels: building/district - district/city (IEA 2014. Energy Technology Perspectives-ETP). The City of Rome is trying to come into line, culturally and strategically, with European standards of environmental health and energy savings.

The City of Rome is divided into 19 municipalities (district), each with its own administration and management. The 2nd District (II Municipio) is one with the most relevant urban area to verify the theoretical background of the research as well as to the verification of prerequisites for regeneration strategy choice. The 2nd District evinces a high concentration of structures for basic and university education, advanced



research and healthcare services, but also relevant buildings for public and private services and several student housings [10].

According to the peculiar concentration of this type of buildings of such strategic functions makes it possible to an effective simulation of the potential effects of a series of interrelated renovation actions, both at a building scale and at local level. The District dimension, the building concentration and a good associative structure and participative characterization of this territory can finally facilitate the involvement of potential users for the growth of the smart community at a district level, increasing the benefits of the social inclusion in each renewal action on buildings.

These buildings are strategic case studies because they are representative for dimensional cubature, for their constructive characteristics and for the chronological distribution of their construction in order to conduct an analysis of substantial statistical significance. An operation carried out on building complexes with similar characteristics will allow us to direct a large part of the interventions on the entire stock, focusing immediately on the causes of the problems of degradation and inefficiency and the most effective lines of action to take.

The recognition of the consistency of the existing building stock and the subsequent selection of the buildings that are representative of general conditions make it possible to compare results and draw from them intervention guidelines that are applicable to almost all of the public utility building stock. Many energy efficient measures and technologies in retrofit processes can be developed to improve building energy performance for the lighting, window, HVAC, insulation system etc. These include replacing/converting LED, CFL and T8 tubes for lighting systems, VFD chiller system, VAV boxes, conversion of hot water boiler etc. for HVAC system, and mechanical systems such as variable flow primary/secondary systems. Smart lighting technology, which is combined smart LED lights and wisdom lamp holders, hardware and software, can bring more than 30% of energy saving in library and school buildings.

Smart, innovative, intelligent and energy-efficient buildings are concepts that have characterized recent academic literature as the recent funded projects under the 7thFP (Joint initiative EeB-PPP). In this context "Smart Buildings" can be defined as attractive for citizens and investors, as based on an alliance between economic innovation, environmental sustainability, social and cultural development and open governance, in line with the European Strategy 2020 and the EERA (European Energy Research Alliance) Joint Program Initiative on Smart cities.

According to a typology approach, the non-residential categories had been firstly defined (12

major categories each including a certain number of specific subtypes, see Table 1), and then the ones with special consideration to the main relevance in the district and/or due to their quantitative relevance were chosen among the others. An analysis of selected buildings from the research initiative shows that in some buildings, there is no distinct daily time profile for the electricity consumed for heating and cooling, whilst in other buildings, night setbacks or fixed operating times lead to very characteristic daily electricity consumption profiles for heating and cooling [11].

Category	Function
Education Buildings	Schools, Kindergartens, Universities
Housing for elderly	Residential buildings for the third age
Office and Administration Buildings	Banks, Insurance-buildings, Government buildings, Official buildings
Factory Buildings	Large-scale enterprises, Manufacturing buildings
Workshop Buildings	Craft, Trade
Health Buildings	Hospitals, Polyclinics
Retail and Trade Buildings	Shopping Centre, Food, Non-Food
Warehouses	Central Warehouses, Shipping Depots
Sports Halls	Private, School and College Sports, Indoor Centres
Indoor Swimm. Pools	Leisure Pools, Small Indoor Swimming Pools
Cultural Buildings	Operas, Theatres, Concert Halls, Cinemas, Exhibition Buildings
Accommodation Buildings	Hotels, detached Restaurants

Table 1: Typological categories for non-residential buildings.

Efforts to increase the rate and depth of renovation will stimulate at the same time the market uptake of highly efficient and renewable technologies and construction techniques that can deliver the expected increase of the actual energy performance of buildings.

Different new design approach for building energy management systems (e.g. Modelica) which are an object oriented description language, these methods create a simulation model of the entire building, including the technical equipment, weather and occupancy.

In this context, the typologies for the support of industrialized modular retrofit of existing types of social housing and of existing types of school buildings can serve as a model for the development of a typology handbook for

industrialized modular retrofit of public utility buildings. Renovating public buildings in the traditional (and thus lengthy) way as used for home dwellings, would mean moving entire user populations for the time of the retrofitting process, which is hardly feasible and certainly very expensive (costs of twice moving and re-housing). For this reason, the vision is to transform the retrofitting construction sector from the current craft and resource-based construction towards an innovative, high-tech, energy efficient industrialized sector. In this project, new retrofit solutions in planning, design, technology, construction, operation and use of buildings are investigated and will be evaluated.

In a modular retrofit system concept, industrialized craftsmen, within a temperate indoor working climate, produce the new facade and roof components in factories, safely and under much better working conditions than at the construction site. The components (modules) are pre-fitted with heating, cooling and ventilation ducts and service ducts for energy and data transport and are then transported to the site and mounted on site with cranes, within a very short period (days instead of weeks / months).

### 3 RESULTS

The ongoing investigation led to the identification of the dimensional characteristics of a large part of buildings (mainly school buildings), information on electrical and heat consumption over the previous three years, inspections for the examination and direct verification of data, as well as providing a detailed survey and thermographic and thermos physical surveys useful for the characterisation of the building envelope in terms of thermal performance.

Energy management systems will be able to reduce the energy consumption in buildings. This enables informed decisions about the investment and operating costs, energy savings and comfort to be made at an early stage. The use of simulation based verification and optimisation methods dramatically simplifies the complex design process for trades planning energy management.

When planning a retrofit, multiple performance strategies and actions have to be considered. For this reason, a decision support methodology will be used to select the most appropriate retrofit strategy/actions. The simulation-based retrofit design process consists of three phases: (i) Analysis of existing conditions, (ii) Development of retrofit strategies/actions (+evaluation), (iii) Implementation of retrofit strategies/actions.

The specifications for the building management system will also derive from the requirements for the building behaviour defined from the user profiles and the possibilities offered by the

building services technology. The states of the building services technology and their temporal development will be described using a so called state machine which responds to changing sensor values in the building and, based on parameterised functions, determines suitable regulating variables for the respective building services technology. These assignments can be changed during simulations across the year in order to optimise the defined quality criteria.

At the same time, the share of renewable energies in a grid of energy-efficient interactive Buildings, with electricity based technologies for heating and cooling (e.g. heat pumps, compression chillers, CHP plants) will contribute to relieving the electricity system and reducing the demand for electrical storages and energy conversion processes by shifting the electricity consumption for heating and cooling temporarily, using technical storages and the mass of the building to store the energy as heat or cold.

This will enable surplus solar and wind power to be used and stored with a high efficiency as heating and cooling energy. Control and energy management concepts will be necessary to ensure that buildings interact favourably with a dynamic power grid and assume a more active role as part of the energy system.

Some important activities are now going to be sufficiently anticipated, in order to ensure the overall energy performance of the buildings and the grid simulations. For these reasons, considerable work on energy performance monitoring, socio-economic studies, E-GIS and software design have to be carried out in parallel, making the renovation project not only a building construction project but also providing a holistic approach to integrate rational use of energy at a neighbourhood scale.

Actually a renovation project at district scale included an important task on the monitoring of the global performances of the buildings such as energy consumption, comfort criteria and quality of renewable energy systems. Monitoring techniques serve to assess the actual and the post-renovation performance of the buildings. Monitoring activities are classified in terms of stakeholders involved, technologies and feedbacks to actors, based on past experiences, in order to provide guidance on the choice of a particular solution.

As no actual standard exists for such large scale monitoring activity, a reflection on the methodologies is needed to highlight the strong/weak points of each of them depending on the initial objectives of the monitoring.

The program represents a unique opportunity of the demonstration project (scale of the project, strong political commitment) to innovate and enhance existing energy policies and practices at local level by: transforming project experience

into municipal policy, regulation and best practices, thus ensuring immediate replication of the results, proposing evolution for regional and national policies and regulations, making the lessons available to others via the development of policy guidance notes thus facilitating the adoption and use of this innovation by other municipalities and urban planners.

The academic implication of the PDTA Department in the project as promotor proves to be highly beneficial. It provides credibility and legitimacy to the project actions, while taking one step forward the internal reflection regarding the leading role of the university for the development of sustainable urbanism and energy efficiency.

Last but not least, the replicability of this activity also demands a highly mechanization degree since tele-control and monitoring systems advance very quickly.

#### 4 DISCUSSION

The greatest challenge in the renovation market is to find new solutions for an existing situation (built structure and its use). An advanced retrofit strategy aims at establishing a holistic building strategy for the entire, remaining life cycle of the building. The ultimate option in the building strategy is to construct a new building in replacement.

Since the non-residential buildings exist in all communities (e.g. there are more than 370.000 school buildings alone in the EU) the set of technical solutions would be applicable in all cities and regions throughout the EU for all those non-residential buildings that have a structure which allows modular retrofit [12].

The aim of the research program is to evaluate the implications of different critical parameters for reaching the EU2020 energy renovation goals, starting from the lack of a consolidated classification regarding different type of utility buildings such as schools, universities, healthcare and administration buildings [13]. On the other hand, the aim is to overcome also technological and knowledge barriers alongside the transition towards the smart building diffusion, as well as to share the good practices across several national and international contexts. The technology of modular retrofit of existing housing is in full development however the solutions cannot be transposed automatically to utility buildings because of several factors and barriers that impede the diffusion of the industrialized mass retrofit market for utility buildings.

#### 5 CONCLUSIONS

An urgent need for adaptation and transfer of these industrialized technologies towards utility buildings is required and for the creation of the instruments for master planning and stakeholder

involvement for adequate retrofit and use of public utility building stock.

The following steps have to be implemented in the future to create a non-residential buildings typology tool:

- (i) Create, based on different available sources, database for non-residential buildings
- (ii) Analysis of data to build up the typology, relevant tool
- (iii) Create final building matrix for defined buildings category

By promoting and thus increasing the use of these smart technologies in the utility building renovation market, demand will rise creating more offer of automated, industrialized production, leading to prices dropping towards or even below the existing price level for traditional renovation.

#### 6 REFERENCES

1. Rey, E., Office building retrofitting strategies: multi criteria approach of an architectural and technical issue, *Energy and Buildings*. 2004. 36: p. 367-372.
2. RENAISSANCE (2012). Innovative Buildings for Low-Energy Cities.
3. Boarin, P., Edilizia scolastica. Riquilificazione energetica e ambientale. Metodologie operative, requisiti, strategie ed esempi per gli interventi sul patrimonio esistente, 2010, Edicom. Monfalcone.
4. Arbizzani, E., Civiero, P., Ortega Madrigal, L., Serrano Lanzarote, B., "Smart solutions for low-income buildings rehabilitation: international researches and experiences". *Techne. Journal of Technology for Architecture and Environment*. 2015. Firenze University Press, Firenze: 10/2015, pp. 222-231.
5. Arbizzani, E., Civiero, P., Clerici, Maestosi P., Smart Interactive Buildings. Topic: Education and Knowledge Management. In: *World SB 14 Barcellona*. 2014: Barcellona, Spain.
6. EU, Smart Reno-Up 2020: Smart Renovation of Utility Patrimonium to the EU 2020 targets. 2013.
7. Bahr, V. (ed.), *Energy Solutions for Smart Cities and Communities. Lessons learnt from the 58 pilot cities of the CONCERTO initiative*. 2014. Offizin Scheufele: Stuttgart, Germany.
8. BPIE, Europe's buildings under the microscope. A country-by-country review of the energy performance of buildings. 2011: BPIE.
9. BPIE, A Guide to Developing Strategies for Building Energy Renovation. Delivering Article 4 of the Energy Efficient Directive. 2013: BPIE.
10. Calice, C., Clemente, C., de Santoli, L., Fraticelli, F. Guidelines for the retrofit of the school building stock for sustainable urban

regeneration of the city of Rome. 2011. WIT Transactions on Ecology and the Environment, 155, pp. 417-428.

11. Cole, R. J., Regenerative design and development: current theory and practice. Building Research & Information, 2012. 40(1): p 1-6.

12. EIB, "Guidance on Energy Efficiency in public buildings". 2012: EPEC, Luxembourg.

13. TABULA, Typology Approaches for Non-Residential Buildings in Five European Countries - Existing Information, Concepts and Outlook. 2012: Research Report.



## Expanding Boundaries: Systems Thinking for the Built Environment

### DEMOLITION VERSUS DEEP RENOVATION OF RESIDENTIAL BUILDINGS: CASE STUDY WITH ENVIRONMENTAL AND FINANCIAL EVALUATION OF DIFFERENT CONSTRUCTION SCENARIOS

L. Wastiels<sup>1\*</sup>, A. Janssen<sup>1</sup>, R. Decuyper<sup>1</sup>, J. Vrijders<sup>1</sup>

<sup>1</sup> Belgian Building Research Institute (CSTC-WTCB), Avenue P. Holoffe 21, B-1342  
Limelette, Belgium

\*Corresponding author; e-mail: Lisa.Wastiels@bbri.be

#### Abstract

In a context where buildings are required to be and become very energy efficient – also for the existing housing stock – the question arises whether a thorough retrofit really is a better alternative than demolishing the building and re-constructing a new one.

This paper presents a building case study where the environmental and financial impact of different construction scenarios (renovation versus demolition/new construction) are evaluated. It concerns a single-family house, located in Brussels, deeply renovated up to the passive standard by using a box-in-box system. For the analysis, two additional scenarios were defined: one considering more commonly used renovation techniques (installing an external insulation), the other considering a demolition of the existing building and the construction of a new building within the same volume. Life cycle analysis (LCA) and life cycle costing (LCC) are used to gain insights in the environmental and financial impacts of the different retrofitting (or new built) strategies.

The results reveal that the environmental impact of the new building is about 20% higher than that of the box-in-box renovation and that the total life cycle cost of demolition and re-construction is about 30% higher. However, when taking the considerable difference in useable floor space into account, the results also show that the new construction performs significantly better per square meter of heated floor space than the box-in-box renovation – both financially and environmentally. In an urban context where space is scarce, the option of demolition and re-construction thus might be valuable.

#### Keywords:

LCA; Life Cycle Assessment; Construction; Renovation; Case study

## 1 INTRODUCTION

In the context of sustainable development, and more specifically the targeted reduction of CO<sub>2</sub>-emissions, buildings are required to be and become very energy efficient. For the existing housing stock, a deep energy retrofit step is needed in order to meet the required energy standards. Considering the magnitude of such renovations, the question arises whether a thorough retrofit really is a better alternative than demolishing the building and re-constructing a new one.

A building case study is selected and different retrofitting scenarios are defined for the analysis. The scenarios all consider the current standards in terms of comfort and energy consumption. In

addition to the “as-renovated” situation, two alternative scenarios are defined: one considering some commonly used renovation techniques, another considering a complete demolition of the building and the erection of a new building. The different alternatives are compared to each other from an environmental point of view by use of life cycle analysis (LCA).

Naturally, the costs related to the retrofitting or demolishing of the building might strongly influence the feasibility of these different scenarios. Therefore, also a life cycle costing analysis (LCC) is performed for the different scenarios. As a result, the feasibility of retrofitting versus demolition and new construction can be

discussed from both an economic and an environmental point of view.

## 2 CASE STUDY

### 2.1 Building case study

The project in scope is a single-family house with three floors, located in Schaarbeek, Brussels. The house was going to be demolished, until the owners decided to keep it for deep renovation up to the passive house standard. External insulation was not possible due to city regulations, so the building had to be insulated from the inside. As a result, a completely new wooden structure was erected within the existing structure (box-in-box). The building was renovated within the context of the call 'BATEX – Voorbeeldgebouwen -Bâtiments Exemplaires', which promotes the construction and renovation of buildings with good environmental and energetic performances in the Brussels Capital Region. The very low energy use (passive house standard), reuse of rain water, use of ecological construction materials, reuse of waste materials, attention to soft mobility and use of solar energy for the production of sanitary hot water and electricity all contributed to this award.

### 2.2 Investigated scenarios

The main differences between the considered scenarios are represented conceptually in Fig. 1 (i.e. box-in-box renovation (BB), ETICS renovation (ET) and new construction (NC)).

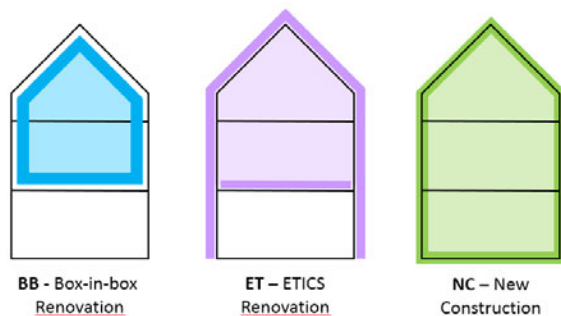

Fig. 1: Conceptual representation of the investigated scenarios.

In the **Box-in-Box renovation (BB)**, the building is insulated from the inside. The ground floor is kept for (unheated) storage because of the limited available free height of the spaces. The heated area consists of a living space on the first floor and bedrooms on the second floor, with a total of 110m<sup>2</sup> of useable (heated) floor area.

In the **ETICS renovation (ET)**, the building is insulated by use of an ETICS (External Thermal Insulation Composite System) on the outside of the building. This is a hypothetical scenario, as adding insulation from the outside was restricted through urban regulations. As in the BB-scenario, the ground floor is kept for (unheated) storage. The heated area consists of a living space on the

first floor and bedrooms on the second floor, with a total of 127m<sup>2</sup> of useable (heated) floor area.

In the **New Construction scenario (NC)**, the original building is demolished and a new building is erected within the same volume. The complete building is insulated. The heated area consists of a living space on the ground floor and bedrooms on the first floor. The attic on the second floor is also insulated so can be considered within the heated volume. This leads to a total useable (heated) floor area of 196m<sup>2</sup>.

Table 1 provides an overview of the most important dimensions and summarizes the main differences between the different scenarios in terms of material use.

## 3 METHODOLOGY

### 3.1 Energy consumption

Even though the different scenarios all strive for a high thermal efficiency of the building, some differences in energy use will exist due to the differences in conception of the buildings (e.g. type of insulation, used floor space). To account for these differences over the building's life time, the energy consumption is calculated for all scenarios using the PHPP-software (PHPP2007). The energy consumption includes the energy consumption for heating, for cooling, for warm water and auxiliary energy (for ventilation system and for circulation pumps for the heat distribution).

### 3.2 LCA approach

The environmental impact of the different scenarios defined earlier is determined by the use of life cycle analysis (LCA). The cradle-to-grave LCAs carried out within this study take into account the principles described within the ISO 14040 international standards series and the European harmonised standards on the environmental evaluation of buildings (NBN EN 15978) and construction products (NBN EN 15804) [1], [2].

As a functional unit for this study, the whole building is taken into account. The reference study period is set to 60 years, corresponding to the expected service life of the building (after renovation or new construction). Materials or components with a shorter service life have to be replaced during the considered reference period. All newly applied construction materials are taken into account; materials that are being reused are not considered as they fall outside the system boundary. Technical installations for heating and ventilation (boilers, radiators, photovoltaic panels, ducts, fans, etc.), sanitary installations (kitchen and bathroom) and electrical installations (wiring, lighting, etc.) are excluded from the study.

Two sets of life cycle impact assessment methods are used to interpret the environmental impact of the considered scenarios: 1) ReCiPe Endpoint (H) v1.10, Europe ReCiPe H/A represented by use of

a single score per scenario (expressed in Points) [3] and 2) the CEN indicators (CML Baseline) as described in EN15804+A1 [2]. The results for the CEN indicators are given on a relative scale (expressed in %).

For this study, the generic Swiss LCI database Ecoinvent v2.2 is used [4], [5]. Most data within this database is representative for Switzerland or

Western Europe. In the current LCA, data for Western Europe is used when available. For Swiss data, the electricity mix is replaced by the European mix. Furthermore, data is harmonised to the Belgian context by considering transportation and end-of-life (EOL) scenarios representative for the Belgian situation [6].

		BOX-IN-BOX RENOVATION (BB)	ETICS RENOVATION (ET)	NEW RECONSTRUCTION (NC)
Building footprint		83 m <sup>2</sup>	93 m <sup>2</sup>	89 m <sup>2</sup>
Total floor area (level 0+1+2)		177 m <sup>2</sup>	194 m <sup>2</sup>	196 m <sup>2</sup>
<b>Useable (heated) floor area</b>		<b>110 m<sup>2</sup></b>	<b>127 m<sup>2</sup></b>	<b>196 m<sup>2</sup></b>
<b>Use</b>	Level 0	Storage space, ceiling insulated	Storage space, walls and ceiling insulated	Living area
	Level +1	Living area	Living area	Bedrooms
	Level +2	Bedrooms	Bedrooms	Attic, insulated
<b>Basement</b>		/	/	/
<b>Exterior walls</b>	Structure	Construction in wood on inside	Maintain existing structure	Construction in wood
	Foundations	Reinforcement using concrete pillars for back façade / reinforcement using I-beams for front façade	Existing foundations	New foundations
	Insulation	cellulose 40 cm + 4 cm hemp insulation	EPS 30 cm	cellulose 40 cm + 4 cm hemp insulation
	Finishing	Cedar wood, only front façade, levels +1/+2	Plaster, all facades, levels 0/+1/+2	Cedar wood, all facades, levels 0/+1/+2
<b>Interior walls</b>		Wooden structure, gypsum panels	Wooden structure, gypsum panels	Wooden structure, gypsum panels
<b>Roof</b>	Structure	Wooden structure	Wooden structure	Wooden structure
	Insulation	cellulose 40 cm + 2 x 6 cm wood fiber panels	glass wool 40 cm	cellulose 40 cm + 2 x 6 cm wood fiber panels
	Covering	Ceramic roof tiles	Ceramic roof tiles	Ceramic roof tiles
<b>Floors</b>	Ground floor / floor level 0	Existing floor	Existing floor	Concrete, PUR insulation, finishing cork
	Floor level +1	New wooden structure, cellulose 40 cm, finishing cork	Existing floor, PUR 12 cm, finishing cork	New wooden structure, finishing cork
	Floor level +2	New wooden structure, finishing cork	Existing floor, finishing cork	New wooden structure, no finishing
<b>Windows</b>	Openings	Existing + new openings	Existing + new openings	More/larger windows
	Frames	wood	wood	wood
	Glass	triple glazing	triple glazing	triple glazing
<b>Stairs</b>	Outside	existing stair	existing stair	none
	Interior	1 new stair +1/+2, wooden	1 new stair +1/+2, wooden	2 stairs, from 0/+1 and +1/+2, wooden

Table 1: Summary of the main differences (surface and materials) between the scenarios considered in this study.

### 3.3 LCC methodology

The Life Cycle Costing (LCC) calculations are executed according to ISO 15686-5 on life cycle costing [7]. Construction costs, operational costs (energy, cleaning, etc.), maintenance costs (preventive maintenance, curative maintenance, replacements, etc.) and the end-of-life costs are

taken into account. The following costs are excluded from the LCC-analysis: externalities (costs caused by the building, but at the expense of a third party), non-construction costs, income (rental income, subsidies, etc.), acquisition costs, water consumption, regular cleaning costs and

energy consumption for lighting and housing appliances.

The Life Cycle Cost will be described using the Net Present Value (NPV) as economic indicator. All cash flows occurring during the period of analysis are discounted back to their present value, after which they are summed up. A reference study period of 30 years is considered for the LCC. A nominal discount rate of 3.5% is used for the study (including sensitivity analysis).

## 4 RESULTS LIFE CYCLE ASSESSMENT (LCA)

### 4.1 Comparison total building cradle-to-grave (ReCiPe)

A first comparison of the environmental impact of the different scenarios is made using the ReCiPe methodology. Results show that the total environmental impact of the NC-scenario is larger than the other two scenario's (BB and ET), which are comparable in terms of total life cycle environmental impact (see Fig. 2).

The distribution of the impacts over the different life cycle phases is similar for the different scenarios, with the highest impacts related to the production phase and the energy consumption during the use phase. These phases represent 82-85% of the total life cycle impact for all scenarios. For the BB-scenario and NC-scenario the impact of the production phase is slightly higher than the impact related to the energy consumption. For the ET-scenario the impact related to the energy consumption is significantly higher because of the lower thermal efficiency of the building. The construction phase (1%) and EOL phase (5-6%) are small for all scenarios. The impacts related to the replacements are slightly higher (9-11%) but still small in comparison to the production and energy use phase. The impact of replacements is the highest for the NC-scenario where more windows have to be replaced, as well as the complete wooden cladding on all 4 facades.

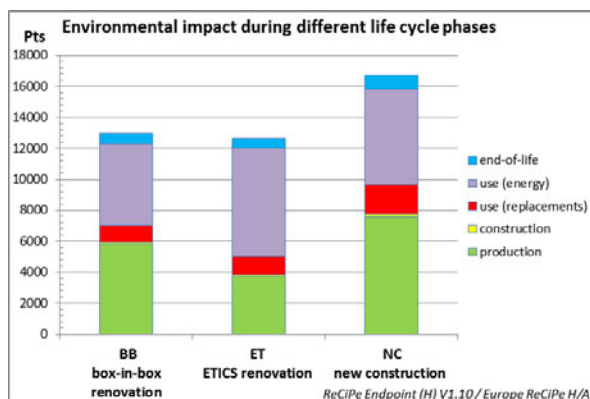

Fig. 2: Comparison of the environmental impact of the different scenarios over the building's complete life cycle (cradle-to-grave).

In the discussion above it should be noted that the installations themselves have not been modelled but would lead to a significant contribution in the production, use (replacements) and EOL phase. This would thus alter the comparison of the different phases for each scenario, with higher impacts for all phases except the energy consumption phase.

### 4.2 Comparison in relation to floor area (ReCiPe)

As seen in the results above, the new construction results in higher environmental impact for almost all life cycle phases and building elements. However, the new construction (NC) also has a larger potential in terms of useable floor space as the contained (heated) volume houses three floor levels instead of only two in the other scenarios (BB and ET). Therefore it seems useful to compare the total impacts of the buildings in relation to the useable floor space (see Table 1).

Looking at the environmental impact in relation to the floor area provides some valuable and interesting nuances in the results (Fig. 3). First of all, the comparison per  $m^2$  leads to a lower environmental impact for ET than for BB. Whereas the total life cycle impact is similar for both scenarios when considering the total building impact (see Fig. 2), the impact per square meter of useable floor space is lower in case of the ET-scenario (Fig. 3).

The discussion of these results is more difficult for the new construction. When considering the complete heated floor area, the NC-scenario scores significantly better than both the ET- and BB-scenario (see Fig. 3). However, the second floor is not finished for the NC, and given the significantly larger total floor space one could state that the functional unit does not allow for a correct comparison. Nevertheless, the wish for as much useable floor space as possible remains very important, especially in an urban context.

The results where only two floors of the new construction are considered as useable floor area ( $129m^2$ ) reveal that the environmental impact of the new construction is slightly higher than the box-in-box renovation when considered per  $m^2$  of useable floor area (see Fig. 3).

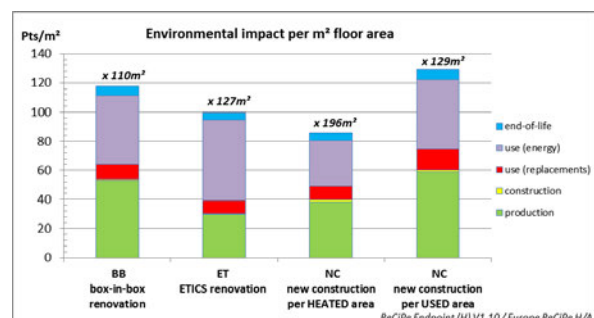

Fig. 3: Environmental impact for the three scenarios per  $m^2$  of floor area.



### 4.3 Comparison of scenarios for individual impact categories (CEN indicators)

The consideration of individual impact categories according to the 7 CEN indicators (see Fig. 4) allows for a more nuanced comparison of the scenarios. The impact represents the impact for the complete renovation and does not take into account the differences in useable floor area (m<sup>2</sup>). The results show that the NC-scenario has the highest environmental impact for all categories. The impact of the BB-scenario is about 20% lower for each indicator. Finally, the impact of the ET-scenario varies according to the indicator. For Photochemical oxidation the impact of EC is the same as for the new construction NC. For Abiotic depletion (ADP) and Eutrophication (EP) the impact of EC is significantly lower than that of BB (-20%). For the remaining indicators, the impact of the ET-scenario is comparable to that of the BB-scenario.

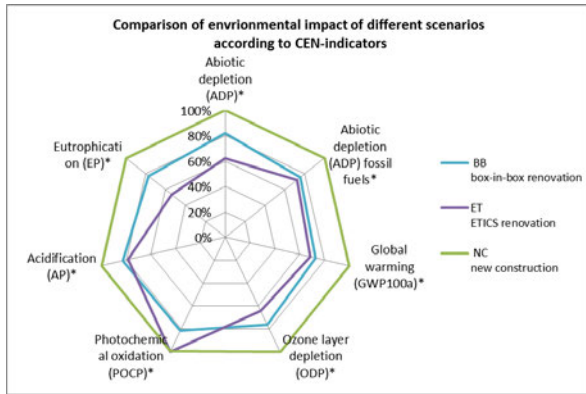

Fig. 4: Environmental impact of the different building and renovation scenarios according to the 7 CEN-indicators.

### 5 RESULTS LIFE CYCLE COSTING (LCC)

The life cycle costs are summarized in Fig. 5, together with the resulting total Life Cycle Cost. The end-of-life costs, calculated as residual values (via linear depreciation), are included as negative costs.

The ET-scenario has the lowest Life Cycle Cost, but the difference with the BB-scenario is small (3.5% difference). The LCC of the NC-scenario is significantly (34%) higher than the ET-scenario.

The energy cost (operation cost) represents only a minor part of the LCC for these nearly passive buildings. Especially for the BB and NC-scenarios (1.8% and 2.1% of the total LCC respectively), but also for the ET-scenario with an operations cost of only 3.8% of the total LCC.

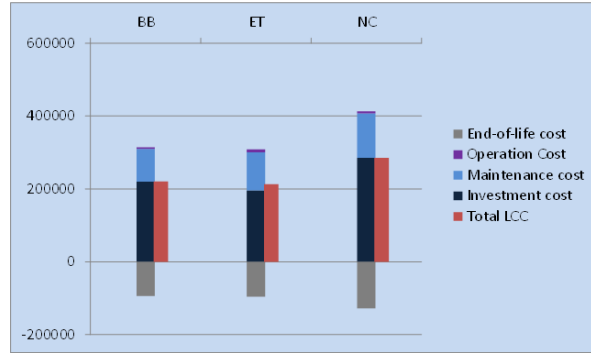

Fig. 5: Total life cycle cost.

In the calculations above, the total life cycle costs are represented without consideration of the differences in useable floor space for the different scenarios. Comparing the costs in relation to the useable floor space reveals that the NC-scenario has the lowest life cycle cost per square meter – being 27% lower than for the BB-scenario (see Fig. 6). Also between the BB and ET-scenarios (with comparable absolute life cycle cost) a difference of 16% is found when considering the cost/m<sup>2</sup>.

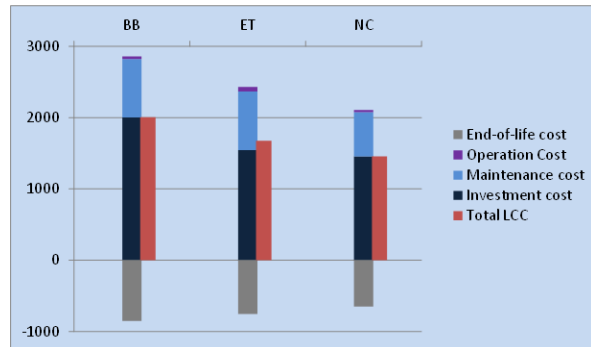

Fig. 6: Total life cycle cost per square meter.

### 6 DISCUSSION COMBINATION LCA/LCC

As both environmental indicators and economic indicators have different units of measurement it is difficult to compare results from the LCA and LCC analyses. However, Fig. 7 shows a relative comparison of the scenarios, where the scenario scoring the worst for an indicator is used as the 100% reference. For the LCA, the Initial impact of production and the Total life cycle environmental impact are considered (both using ReCiPe). For LCC, the Investment cost and the Total life cycle cost are included.

The graph shows that the new construction (NC) scores about 20% worse than the box-in-box renovation (BB) for the main LCA and LCC indicators. The ETICS renovation (ET) has a similar scoring to the box-in-box renovation (BB), except for the LCA Production impact where it scores significantly better. The latter can be explained by the fact the ET-scenario consumes significantly less materials than the other scenarios. The resulting lower thermal efficiency,

however, compensates any gains over the considered life cycle of 60 years.

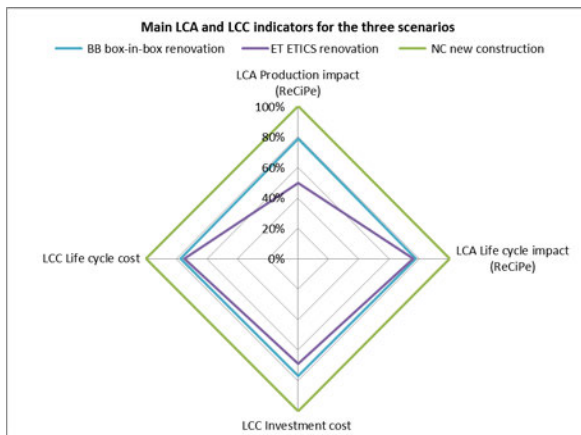

Fig. 7 : Main environmental and economic indicators for comparing the three scenarios BB, ET and NC.

## 7 CONCLUSIONS

For the present case study, the results reveal that the NC-scenario (new construction) has the largest overall environmental impact and the highest life cycle cost: the environmental impact of the new building is about 20% higher than that of the box-in-box renovation (BB-scenario) and the total life cycle cost of demolition and reconstruction is about 30% higher. However, when taking the considerable difference in useable floor space into account, the results reveal that the new construction (NC) performs significantly better per square meter of heated floor space than the box-in-box renovation (BB) – both financially and environmentally. The higher total environmental impact and higher total costs generated during the demolition/new construction are thus compensated by a gain in useable floor space.

Considering the total environmental impact and total life cycle cost, the ETICS-scenario performs similar to the BB-scenario. The environmental impact of the materials used for the ET-renovation is lower than that of the BB-renovation. However, this difference is compensated by the higher impact for energy during the use phase in the ET-scenario. In terms of costs, the ET-scenario has the lowest Life Cycle Cost, but the difference with the BB-scenario is only 3.5%. When considering the impacts per square meter, the ET-scenario performs better than the BB-scenario because of the larger useable floor space (related to insulating from outside instead of inside).

To conclude, the scenario considering the demolition and new construction leads to the highest total environmental impact and the highest life cycle cost. However, considering the additional floor space that can be created in a new construction, this option might be a valuable one, especially in an urban context where space is scarce.

## 8 ACKNOWLEDGMENTS

The authors thank the architects for providing the detailed information on the case study. This study was performed in the context of the Innoviris Strategic Platform Environment 2012 – Brussels Retrofit XL – funded by the Brussels Capital Region.

## 9 REFERENCES

1. Nationaal Bureau voor Normalisatie / CEN, *NBN EN 15978 - Sustainability of construction works – Assessment of environmental performance of buildings – Calculation method*. 2012, p. 63.
2. European Committee for Standardisation, *EN 15804:2012+A1:2013 - Sustainability of construction works - Environmental product declarations - Core rules for the product category of construction products*. 2013.
3. M. et al. Goedkoop, *ReCiPe 2008, A life cycle impact assessment method which comprises harmonised category indicators at the midpoint and endpoint level, 1st ed., Report I: Characterisation*. VROM, 2009.
4. R. Frischknecht, N. Jungbluth, H.-J. Althaus, G. Doka, S. Hellweg, R. Hirschler, T. Nemecek, G. Rebitzer, and M. Spielmann, "Ecoinvent report n° 1. Overview and methodology," 2007.
5. "Ecoinvent data v.2.0." [Online]. Available: <http://www.ecoinvent.ch>.
6. L. Delem, J. Van Dessel, A. Janssen, K. Allacker, F. De Troyer, W. Debacker, L. De Nocker, K. Peeters, C. Spirinckx, and R. Servaes, "Environmental Profile of Building elements," 2013.
7. International Standardisation Organisation (ISO), *ISO/DIS 15686-5 - Buildings and constructed assets -- Service-life planning -- Part 5: Life-cycle costing*. 2008.



## Expanding Boundaries: Systems Thinking for the Built Environment

### RETROFITTING MEASURE VS. REPLACEMENT – LCA STUDY FOR A RAILWAY BRIDGE

F. Gschösser<sup>1\*</sup>, R. Schneider<sup>2</sup>, A. Tautschnig<sup>1</sup>, J. Feix<sup>3</sup>

<sup>1</sup> Leopold-Franzens University of Innsbruck, Unit of Project and Construction Management, Technikerstraße 13, A-6020 Innsbruck, Austria

<sup>2</sup> Prof. Feix Ingenieure GmbH, Nymphenburger Straße 5, D-80335 Munich, Germany

<sup>3</sup> Leopold-Franzens University of Innsbruck, Unit of Concrete Structures and Bridge Design, Technikerstraße 13, A-6020 Innsbruck, Austria

\*Corresponding author; e-mail: florian.gschoesser@uibk.ac.at

#### Abstract

The LCA study analyses a short-term retrofitting measure carried out for a railway bridge of the railway line Bamberg-Rottendorf (Germany). The retrofitting extends the lifetime of the bridge for further 15 years. Without this service life extension, the bridge would have been closed within half a year. The retrofitting site works were completed within 4 weeks without an impact on rail traffic. The measure increases the flexural strength of the bridge structure by screwed steel plates, which act as tension elements ("external reinforcement").

The LCA results for the retrofitting are compared to results of a total replacement of the bridge structure. The duration of planning and construction processes for a new bridge was estimated to be 2 years in total, what would have caused a closure of the rail track for 1½ years. Therefore, for the LCA of the bridge replacement a detour of 50 km over the whole closure period is considered in addition to construction related processes. The new bridge construction was defined to be a double-webbed T-beam carried out as a prestressed concrete structure.

The analysis period of the LCA study was set to 15 years including the new construction of the bridge after the retrofitting measure becomes ineffective. For both the retrofitting measure and the replacement of the bridge, no influential maintenance processes are required over the analysis period.

The results of the analysis show the great influence of the route closure and the associated detour. Already one day of route closure causes about twice the amount of environmental impacts as the entire retrofitting measure. Taking into account the whole closure period shows a marginal influence of all construction related processes and underlines the environmental relevance of transport distance extensions. This study furthermore demonstrates the environmental influence of route-shortening infrastructure such as bridges and tunnels and their reliability.

#### Keywords:

Life Cycle Assessment; Railway bridge; Retrofitting measure; Replace; Route closure

## 1 INTRODUCTION

This study analyses a short-term retrofitting measure carried out for a bridge on the railway line Bamberg-Rottendorf (Germany) by applying the Life Cycle Assessment (LCA) methodology. The results are compared to the environmental impacts caused by a complete replacement of the bridge construction.

The existing bridge structure was built in 1968 as a skew two-span girder. The prestressed concrete construction has a total span of 35 m (2 x 17,5 m). The two separated beams of the superstructure of the bridge were carried out as single-cell box girder.

The prestressing steel applied for the existing structures has a high tendency to stress

corrosion. Therefore, the individual prestressing tendons can crack gradually without recognizing these cracks from outside. In combination with the little amount of reinforcing steel this causes the risk of a sudden failure without visible crack formation.

Based on this improbable, but possible scenario, the Federal Railway Authority would have closed the bridge and thus the railway line Bamberg-Rottendorf at the beginning of 2015 for the time span of the replacement. This would have caused a detour of 50 km for all trains over an alternative route for one and a half years.

The retrofitting measure was completed within four weeks and did not cause a closure of the railway route. Furthermore, the traffic flow on the crossing highway A70 was guaranteed by shifting the single lanes according to the construction progress of the retrofitting measure. The retrofitting extends the lifetime of the bridge for further 15 years. After these 15 years the bridge needs to be replaced, what can be prepared with an appropriate period of time and without any closure of the railway route.

## 2 LIFE CYCLE ASSESSMENT

The life cycle assessment (LCA) methodology is applied to determine environmental aspects and

potential environmental impacts occurring throughout the life cycle of a product or service. A complete LCA according to ISO 14040 [6] and ISO 14044 [7] contains the following elements:

- Goal and scope definition
- Life cycle inventory
- Life cycle impact assessment
- Evaluation

### 2.1 Goal and scope

The goal of the LCA study is to compare the environmental impacts of the bridge retrofitting, which was carried out in four weeks and did not cause a closure of the railway line, with the replacement construction of the bridge with the consequence of a closure of the railway line for one and a half years.

According to engineer experience the planning, awarding and construction of a new bridge structure would have taken two years in total. However, it can be assumed that the planning would have started at the same time as the bridge retrofitting (Start 2nd half of 2014), i.e. the period for the line closure can be set to one and a half years (approx. 550 days). Therefore, the assessed scope and the system boundaries of both variants analysed can be defined as shown in Fig. 1.

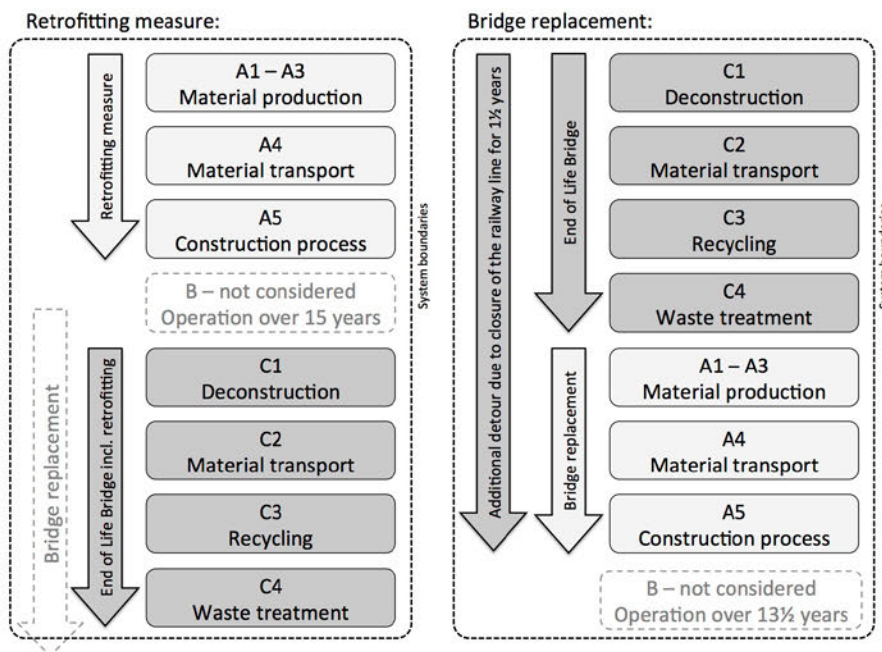

Fig. 1: Scope and system boundaries of the LCA study.

The denomination of the individual life cycle phases in Fig. 1 (A1-A3, A4, ...) is in accordance with standards of CEN TC350 (Sustainable Buildings and Civil Engineering Works).

The analysis period was set to 15 years and corresponds to the lifetime of the bridge structure after the retrofitting measure.

For both variants no influential maintenance measures are expected during the analysis period. Therefore, the operation phase (including maintenance, cleaning, etc.) is not considered in the LCA study, because it is identical for both variants.

Only the additional detour (50 km extra) caused by the usage of the alternative route will be considered for the replacement variant during the closure period.

In order to keep the construction phase for the bridge replacement after the end of life of the retrofitted structure as short as possible, the construction of the new bridge structure will be started before the deconstruction of the existing structures to be able to just “slide in” the finished new structure.

## 2.2 Life cycle inventory

During the life cycle inventory phase of the LCA all material and energy flows (inputs and outputs) necessary for the specific processes of the analysed life cycle phases are collected [6].

The materials (A1-A3) required for the bridge retrofitting are based on the shop drawings of the measure. The materials for the bridge replacement were estimated based on engineering experience.

For the bridge replacement only the replacement of the superstructure (without abutments and piers) is taken into account. The transport (A4) of the materials for the retrofitting was carried out by a lorry over a distance of 140 km. The concrete for the new construction is transported by a concrete mixing lorry from a nearby concrete mixing plant (10 km). Reinforcing and prestressing steel for the new structure will also be transported by lorry over a distance of 140 km. Based on experiences made throughout previous LCA studies it is known that construction processes (A5) generally have minor impact on the LCA results (compared to material production processes) due to low energy and material requirements. In order to reduce the effort for data collection, the construction processes are considered with 2% of the ecological impacts of material production processes [8]. Also the impact for deconstruction processes (C1) is set to 2% of the environmental impacts of material production processes.

Regarding the recyclability of the deconstructed materials it was assumed that 90% of the materials are introduced to recycling processes (C3) and that 10% are delivered to a landfill for inert material (C4).

The transport of deconstructed materials (C2) to recycling plants and inert material landfills is for

both variants assumed to be similar to the material transports to the building site.

During the closure of the railway line Bamberg-Rottendorf all trains will be rerouted via Fürth, what causes a detour of 50 km [9]. In order to include necessary extra processes (i.e. shunting processes, waiting time, etc.) the detour was extended by 10%, what brings a total detour of 55 km.

The passenger transport on the Rottendorf-Bamberg line is performed by 34 daily train runs (17 in each direction). The passenger trains consist of four railway coaches and have a maximum capacity of 250 passengers. For this study it was assumed that all passenger trains have an average utilisation ratio of 75%, what results in 188 passengers per train.

Regarding freight transport the Umweltbundesamt (Federal Environment Agency) numbers 25 train runs per day on the Bamberg-Rottendorf line [10]. The average transport load of the freight trains was set to be 1000 tons.

The closure lasts for one and a half years, i.e. approximately 550 days.

## 2.3 Life cycle impact assessment

The life cycle impact assessment part of the LCA study determines the environmental impacts occurring over the product's life cycle [6]. Due to the limited extent of the paper, only three impact indicators are applied to express the induced environmental impacts (in the overall study a variety of indicators was utilized):

- Global Warming Potential (GWP)  
[kg CO<sub>2</sub> equiv.]
- Acidification Potential (AP)  
[kg SO<sub>2</sub> equiv.]
- Non-renewable cumulative energy demand (NR-CED)  
[kg MJ equiv.]

The life cycle assessment was performed with the LCA-program SimaPro and the LCA-database ecoinvent v2.2 [11].

Before the influence of the closure is taken into account the results for the retrofitting measure and the bridge replacement are compared over the analysis period of 15 years (Fig. 2 to 5).

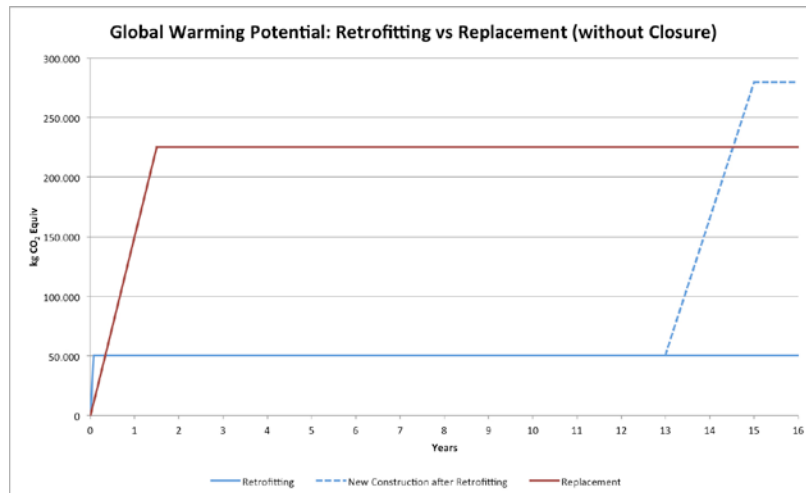

Fig. 2: Retrofitting vs. replacement – GWP.

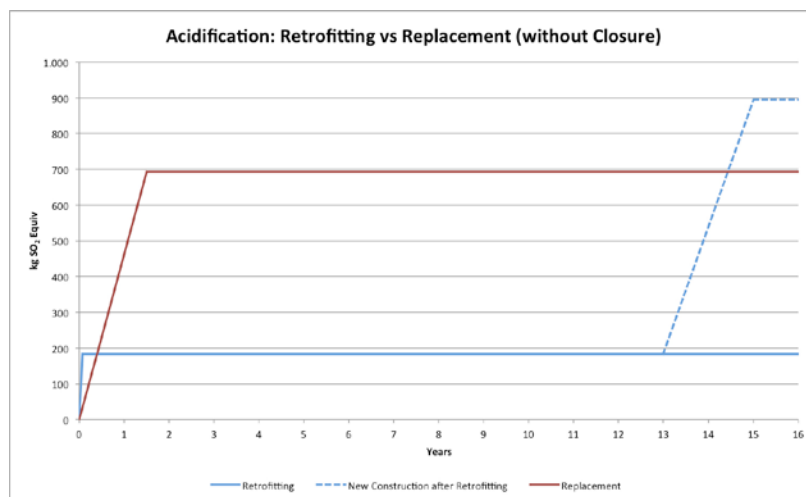

Fig. 3: Retrofitting vs. replacement – AP.

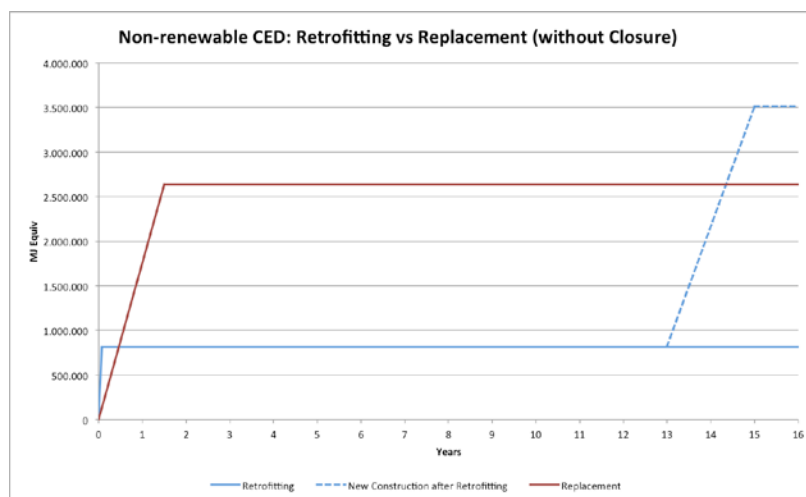

Fig. 4: Retrofitting vs. replacement – NR-CED.

The results for all three indicators show that the retrofitting measure causes lower environmental impacts than the replacement of the bridge. The retrofitting measure extends the lifetime of the bridge for 15 years, what postpones the environmental impacts for a new bridge structure.

Taking a look at the influence of the closure of the railway line demonstrates the main advantage of the retrofitting measure. In order to show the importance of the closure, the environmental impacts for a “one-day closure” will be compared to the results of the retrofitting measure and the bridge replacement (Fig. 5).

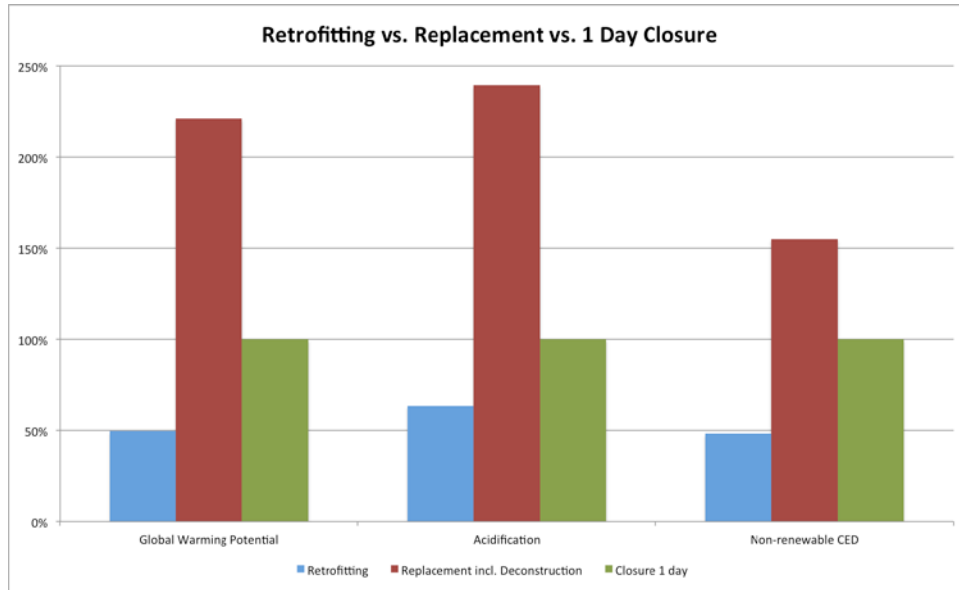

Fig. 5: One-day closure vs. retrofitting and replacement.

Fig. 5 shows that the extra consumption of electricity for a closure of one day causes on average twice the environmental impacts as the complete retrofitting measure.

The bridge replacement causes 1.5- to 2.4-times higher environmental impacts than the one-day closure, which would be compensated after at least three days of closure.

Comparing the environmental impacts of the retrofitting measure and bridge replacement to results of the entire closure of the railway line over one and a half years demonstrates the marginal influence of construction processes in comparison to the influence of detours and extra distances for the railway traffic (Fig. 6).

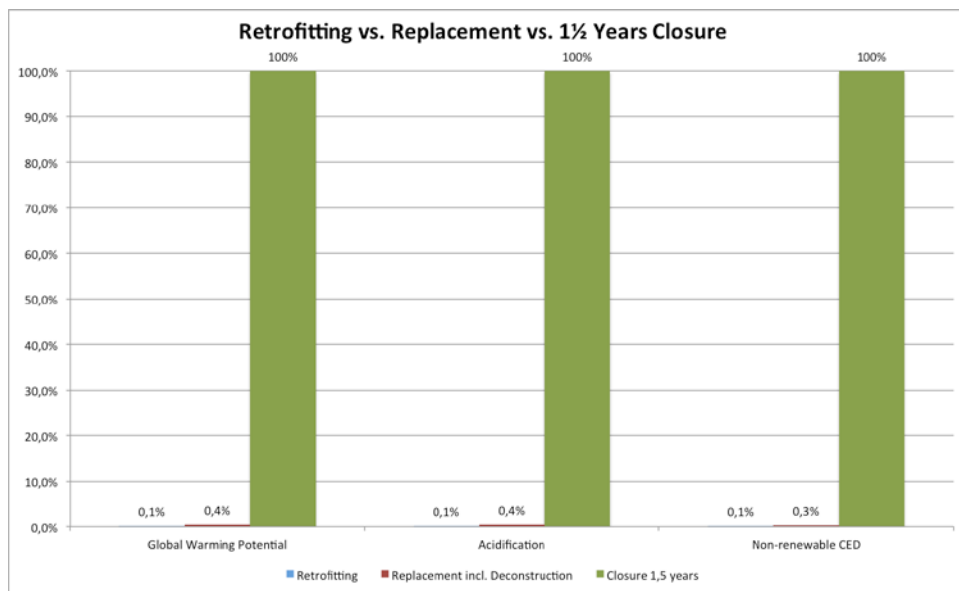

Fig. 6: Closure for 1 1/2 years vs. retrofitting and replacement.

### 3 DISCUSSION AND CONCLUSIONS

This study shows the enormous environmental influence of transport services and transport distance extensions. The performance of the retrofitting measure for the analysed bridge indicates that avoiding a route closure is of higher

environmental importance as the choice of construction methods and materials.

Thus, the study also underlines the environmental importance of distance-shortening engineering structures such as bridges and tunnels. The results of this study correspond with

similar studies, which have shown the environmental influence of strategically important transport infrastructure assets. Hence, this study is one more example that demonstrates the importance of the availability and reliability of infrastructure systems.

#### 4 REFERENCES

1. CEN, *EN 15804 – Sustainability of construction works – Environmental product declarations – Core rules for the product category of construction products*. 2014, CEN - European Committee for Standardization: Brussels.
2. Gschösser, F. and H. Wallbaum, *Life Cycle Assessment of Representative Swiss Road Pavements for National Roads with an Accompanying Life Cycle Cost Analysis*. Environmental Science and Technology, 2013. **47**(15): p. 8453–8461.
3. Santero, N., et al., *Methods, Impacts, and Opportunities in the Concrete Pavement Life Cycle*. 2011, Concrete Sustainability Hub of the Massachusetts Institute of Technology (MIT): Cambridge (MA, USA).
4. ASTRA, NISTRA: *Nachhaltigkeitsindikatoren für Strasseninfrastrukturprojekte - Ein Instrument zur Beurteilung von Strasseninfrastrukturprojekten unter Berücksichtigung der Nachhaltigkeitsziele*. 2003: Bern.
5. CEN. *Overview of CEN/TC 350*. 2015 [cited 15.01.2015 15.01.2015]; Available from: [http://portailgroupe.afnor.fr/public\\_espacenormalisation/centc350/chairman\\_remark.html](http://portailgroupe.afnor.fr/public_espacenormalisation/centc350/chairman_remark.html).
6. ISO, *ISO 14040:2006 - Environmental management - Life cycle assessment - Principles and framework*. 2006, International Standard Office: Geneva.
7. ISO, *ISO 14044 - Environmental management - Life cycle assessment - Requirements and guidelines*. 2006, International Standard Office: Geneva.
8. Gschösser, F., H. Wallbaum, and B.T. Adey, *Environmental analysis of new construction and maintenance processes of road pavements in Switzerland*. Structure and Infrastructure Engineering, 2014. **10**(1): p. 1-24.
9. Wikipedia. *Bahnstrecke Bamberg–Rottendorf*. 2015; Available from: [https://de.wikipedia.org/wiki/Bahnstrecke\\_Bamberg%E2%80%93Rottendorf\\_-\\_Verkehrsangebot](https://de.wikipedia.org/wiki/Bahnstrecke_Bamberg%E2%80%93Rottendorf_-_Verkehrsangebot).
10. Umweltbundesamt, *Schienennetz 2025/2030 - Ausbaukonzeption für einen leistungsfähigen Schienengüterverkehr in Deutschland 2010*, Umweltbundesamt: Berlin.
11. Ecoinvent Center, *ecoinvent database v2.2*. 2010, Swiss Center for Life Cycle Assessment: Dübendorf, Schweiz.





## Expanding Boundaries: Systems Thinking for the Built Environment

### TOWARDS A RELIABLE COMPARISON BETWEEN ENVIRONMENTAL AND ECONOMIC COST OF SWISS DWELLINGS: A MODEL WITH BUILDING MATERIALS' SERVICE LIFE UNCERTAINTY

I.-F. Haefliger<sup>1</sup>, V. John<sup>1\*</sup>, S. Lasvaux<sup>2</sup>, E. Hoxha<sup>2</sup>, A. Passer<sup>3</sup>, G. Habert<sup>1</sup>

<sup>1</sup> ETH Zurich, Chair of Sustainable Construction, Zurich, Switzerland

<sup>2</sup> Université Paris Est, CSTB, Grenoble, France

<sup>3</sup> TU Graz, Institute of Technology and Testing of Building Materials, Graz, Austria

\*Corresponding author; e-mail: viola.john@ibi.baug.ethz.ch

#### Abstract

**Purpose:** In this study, the authors develop a method for the estimation of uncertainties arising from the building material service-life in the context of building LCA and LCC. **Method:** Life Cycle Assessment and Life Cycle Costing analysis were conducted on four newly built Swiss dwellings. The related uncertainties arising for the variability of the building material service lives was evaluated with a Monte Carlo simulation. **Findings:** The outcome of the study shows that the greenhouse gas emissions or the cost uncertainties of the replacements represent between 6 and 16% of the total result of the buildings' LCA or LCC. Furthermore, the uncertainties' estimation of the replacements allows to compare more accurately the buildings' environmental or economic performances.

**Conclusion:** The study highlights the interest of taking into account uncertainty estimation for the replacement phase, especially in the context of more energy efficient buildings.

#### Keywords:

LCA; LCC; uncertainty; building material service life; Monte Carlo simulation

## 1 INTRODUCTION

Buildings are the largest emitters of greenhouse gases, both in the developed and developing countries. In continental Europe, the energy used in buildings is responsible for up to one third of all greenhouse gas emissions [1]. Urgent changes are therefore required to lower those emissions through for instance energy savings, use of renewable resources, or the reuse and recycling of building materials. However, in order to be able to focus on the pertinent and most sensitive aspects of the building sector, it is fundamental to accurately identify which stages of the building life cycle and which construction materials are the main contributors to the buildings' greenhouse gas emissions.

Concerning buildings, the reliability and robustness of Life Cycle Assessment (LCA) results is even more complex than for the other industrial sectors due to their very long service life. Furthermore, some building materials have to

be replaced during a building's life cycle in order to maintain its usability and comfort. In building LCA, the frequency of replacements of those materials is calculated based on a service life (SL) of building material with regard to a building reference study period (RSP) [2]. The SL of building materials can be influenced by many factors which are not only the physical properties of the materials but also socio-economic aspects, such as a change in the consumer needs or a change of the building's user [2]. All these factors will strongly affect the SL of building materials and consequently, the amount of needed construction materials throughout the building's service life and the related greenhouse gas emissions.

The estimation of the uncertainties that are induced by the SLs strengthens the results of LCA and allows for a robust and reliable comparison between building outcomes. Cirotth et al. proposes an overview of different approaches

for the estimations of uncertainties in LCA [3]. They are divided into two types: Monte Carlo simulations or approximation methods. One can find an example in a study undertaken by Hoxha et al. [4], the study estimates the uncertainties in building LCA, originated by the SL with an approximation method.

Since in this study the evaluation of the greenhouse gas emissions of buildings is linked to their economic performance, the uncertainty estimation method developed by Hoxha et al. [4] could not be applied. This is due to the discontinuity of the cost evaluation functions. In this study, the evaluation of the economic performance of the buildings is made through a Life Cycle Costing (LCC) analysis. Arja et al. [5] analyses that most of the studies and researches about uncertainties in LCC for buildings focus mainly on the business or the institution risks, whereas the physical uncertainties such as the one induced by the building materials SL are very little investigated. Therefore, this study tries to develop an uncertainty estimation method regarding the SL applicable for both LCA and LCC, and to evaluate the influence of the SL on LCA and LCC results.

## 2 DATA AND METHODS

For the uncertainty estimation induced by the SL, a Monte Carlo simulation based on 30'000 iterations is conducted for both LCA and LCC. The input distribution for the Monte Carlo simulation is the building material SL, and the output is the number of replacements (Nr) probability distribution for this material. The distributed SL are based on a database provided by the CSTB, which gives the SL mean and standard deviation value for different building materials. Based on those values, normally distributed SL for a specific building material are constructed and used as input distribution for the simulation.

The simulation is implemented in a way that randomly distributes the replacements over the reference study period of the building (Figure 1 (a)) and not linearly over time (Figure 1 (b)). Furthermore, the distribution function of the Nr for the LCC is weighted with a related discounting factor. This means, that the discounting factor is associated with the Nr and not with the cost of a replacement.

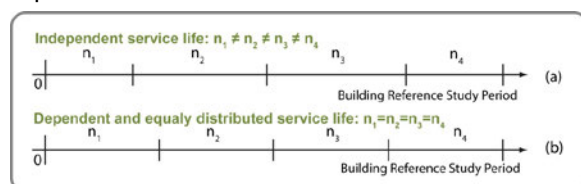

Fig. 1: Distribution of the replacement over the reference study period.

This was possible because all replacement costs were identical with real values over time. The fact that the discounting factor was associated with the Nr made it possible to integrate it into the Monte Carlo simulation, which simplified the uncertainty estimation. This approach made it possible to evaluate the uncertainties for LCA and LCC with the same methodology.

The simulation output for a specific material gave either the probability distribution of the Nr for the greenhouse gas emissions or the Nr for the costs. The probability distribution is fitted with a lognormal distribution.

The simulation was run at the material scale, e.g. a simulation for every building material was conducted. For every material and its related SL, distributed Nr were calculated and for each building material, a minimum and maximum Nr for both LCA or LCC were assessed. This was based on the approach of Slob [6]: the minimum and maximum values were calculated with the geometric mean and standard deviation. A confidence interval of 68% was considered. The minimum and the maximum Nr were calculated by (1).

$$\text{probability} \left\{ \frac{\mu_g}{\sqrt{Cf}} < X < \sqrt{Cf} \cdot \mu_g \right\} = 0.68 \quad (1)$$

Where  $\mu_g$  is the geometric mean of the sample and  $Cf$  is the confidence factor and equals:  $Cf = e^{2\sigma^*}$  with  $\sigma^*$  as the scale parameter of the lognormal distribution. The mean value for the Nr is evaluated by the mean of the lognormal distribution  $\mu$ .

Based on the minimum and the Maximum Nr, it is possible to evaluate the environmental impacts or the cost with (2), (3) and (4).

$$\text{Mean}_i \text{ impact/cost material } i = \mu_i * Q_i * Eval_i \quad (2)$$

$$\text{Min}_i \text{ impact/cost material } i = \frac{\mu_g}{\sqrt{Cf_i}} * Q_i * Eval_i \quad (3)$$

$$\text{Max}_i \text{ impact/cost material } i = \mu_{g_i} \cdot \sqrt{Cf_i} * Q_i * Eval_i \quad (4)$$

Where the index  $i$  represents a material,  $Q_i$  the quantities in kg of material  $i$ , and  $Eval_i$  the evaluation function for the costs or the environmental impacts expressed respectively in [kg CO<sub>2</sub>eq/kg] or [CHF/kg].

In order to estimate the uncertainty at the building scale, it is assumed with the central limit theorem that the uncertainties are normally distributed:

$$\sigma_{building} \approx \sqrt{\sum_{i=1}^k \left( \frac{max_i - min_i}{2} \right)^2} \quad (5)$$

Where  $max_i$  and  $min_i$  are the minimum and maximum replacement cost or environmental impact for a given material at the material scale and  $k$  represents the different materials. The mean value of the replacements at the building scale  $\mu_{building}$  is the sum of the various means at the element scale (6).

$$\mu_{building} \approx \sum_{i=1}^k \mu_i * Q_i * Eval_i \quad (6)$$

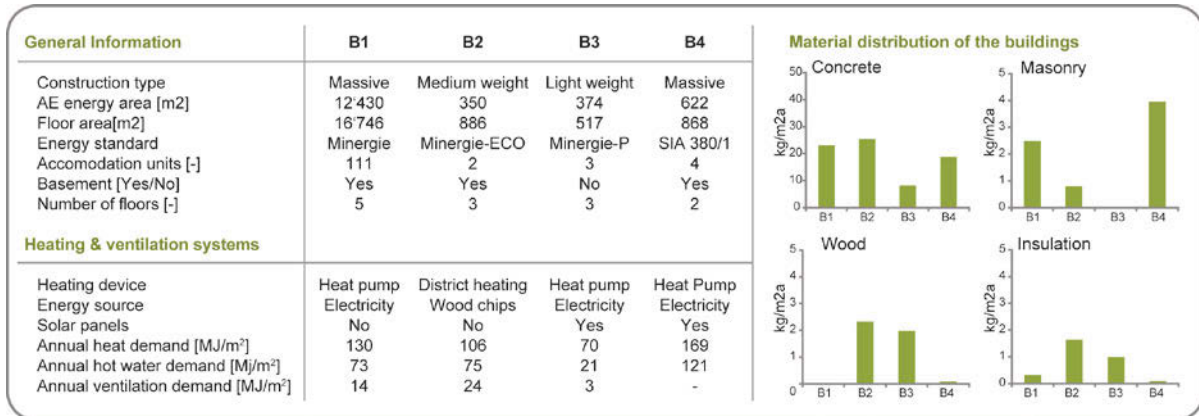

Fig. 2: Main construction materials for the buildings.

## 2.1 Case Study

For this study, four Swiss buildings were selected (B1, B2, B3 and B4). The four buildings show various characteristics: they differ in size, construction type, construction materials, and their energy performances. Thus, they represent a large variety of newly built Swiss dwellings. Figure 2 summarises the building characteristics and their composition in terms of their main building materials. The buildings were selected from the doctoral thesis of V. John [7], where also further detailed building information on the sample is available (buildings: mfh01, mfh02, mfh03 and mfh04).

The four buildings are assessed for their greenhouse gas emissions with the LCA method, and for their costs with the LCC approach. The uncertainty estimation method presented previously is applied to the building sample. The system boundary of the LCA is defined to be a Cradle-to-Grave analysis, focusing on the structural components (Structural components include: walls, ceilings, roof, foundations, windows, external doors.) as well as on the energy consumption during the use phase. Heating and ventilation devices are also taken into account, while transportation and the contributions of craftsmanship are neglected. The greenhouse gas emissions are evaluated with the Swiss Bauteilkatalog BTK [8] and with the indicator Global Warming Potential (GWP) 100a. The tool BTK is based on data from the Swiss ecoinvent database (v.2) ([www.ecoinvent.org/](http://www.ecoinvent.org/)). The LCA results for annual energy demand for heating and ventilation energy demands are taken from the doctoral thesis of V. John [7]. The functional unit is chosen as one square metre of energy reference area per one year of building study period. Figure 3 presents the LCA parameters used in this study.

The system boundary for the LCC is selected in accordance with that of the LCA analysis. The structural element costs are evaluated in Swiss

francs (CHF) using the Swiss Bauteilkatalog [8] with its reference prices for construction materials. The costing is evaluated following the dynamic approach given by the Swiss Research Centre for Rationalisation in Building and Civil Engineering CRB [9], implemented with the reference energy costs proposed by the Canton of Zurich [10]. The costs for the heating and ventilation devices are evaluated based on data from the Swiss Department for Statistics [11]. Those costs account for 12% of the structural construction costs. The results of the LCC are also expressed with the functional unit previously defined. Figure 3 presents the LCC parameters applied in this study.

General parameters	Parameters
System boundaries	Cradle-to-Grave
Building RSP	60 years
Material service life	Normal distributed variable
<b>LCA parameters</b>	
Software and database	Bauteilkatalog (KBOB), ecoinvent v2.0 database
Indicator	Global Warming Potential (GWP) 100a
<b>LCC parameters</b>	
Discount rate	3%
Electricity costs	0.234 [CHF/kWh]
Electricity price evolution	1.4% (linear increase per year)
Wood pellet costs	0.074 [CHF/kWh]
Wood pellet price evolution	1.6% (linear increase per year)
Heat pump COP	3.5
Software and database	Bauteilkatalog (KBOB), guideline prices 2010

Fig. 3: LCA and LCC system parameters ADD GWP 100a.

## 3 RESULTS

The next paragraphs will present the LCA and LCC results and the related uncertainties for the replacements. Figure 4 shows the results for the LCA and LCC results of the four buildings and the related uncertainties. First, the relation of uncertainties and energy performance of the buildings will be highlighted. Secondly, the influence of the uncertainties on the building results for LCA and LCC will be assessed.

The uncertainties related to the replacements represent on average  $\pm 6$  to 16% of the total LCA

or LCC results (Figure 4 (a), (b)). The building (B4) presenting the lowest uncertainties (6.7% for emissions, and 5.9% for the costs), is also the building with the highest energy needs for the utilization phase. Building B2 bears high uncertainties for cost as well as greenhouse gas emissions; it is also one of the most energy efficient buildings. This trend underlines the causality between energy efficient building and uncertainties of the replacement phase. More construction materials, especially insulation materials, are required for high energy-efficient buildings. Therefore, the embodied greenhouse gases and the costs for the construction as well as for the replacement phase are more consistent. In opposition to the energy, greenhouse gas emissions and costs are decreasing with better insulated buildings.

This leads to a shift in the life cycle results; the replacement phase is gaining in importance. Thus, with the development of new energy efficient buildings, the necessity to introduce uncertainty estimation for the replacement of

building materials is becoming more significant for both LCA and LCC.

Furthermore, the integration of uncertainties into LCA or LCC results allows for a stronger comparison of buildings' outcomes. In this case study, the uncertainty estimations enable better ranking of the buildings in terms of greenhouse gases, as well as in term of costs. Indeed, when considering the results of the buildings Figure 4 (c) without uncertainties, B3 is the most environmentally friendly building and B1 the cheapest one. Concerning uncertainty, one can define that the difference in terms of greenhouse gases between those two buildings (B1 and B3) is not significant, whereas in terms of Swiss francs, it is. **Uncertainties allow to compare more accurately the performance of buildings.** In our case, we could tell that B3 is significantly different from B4, regarding life cycle costs.

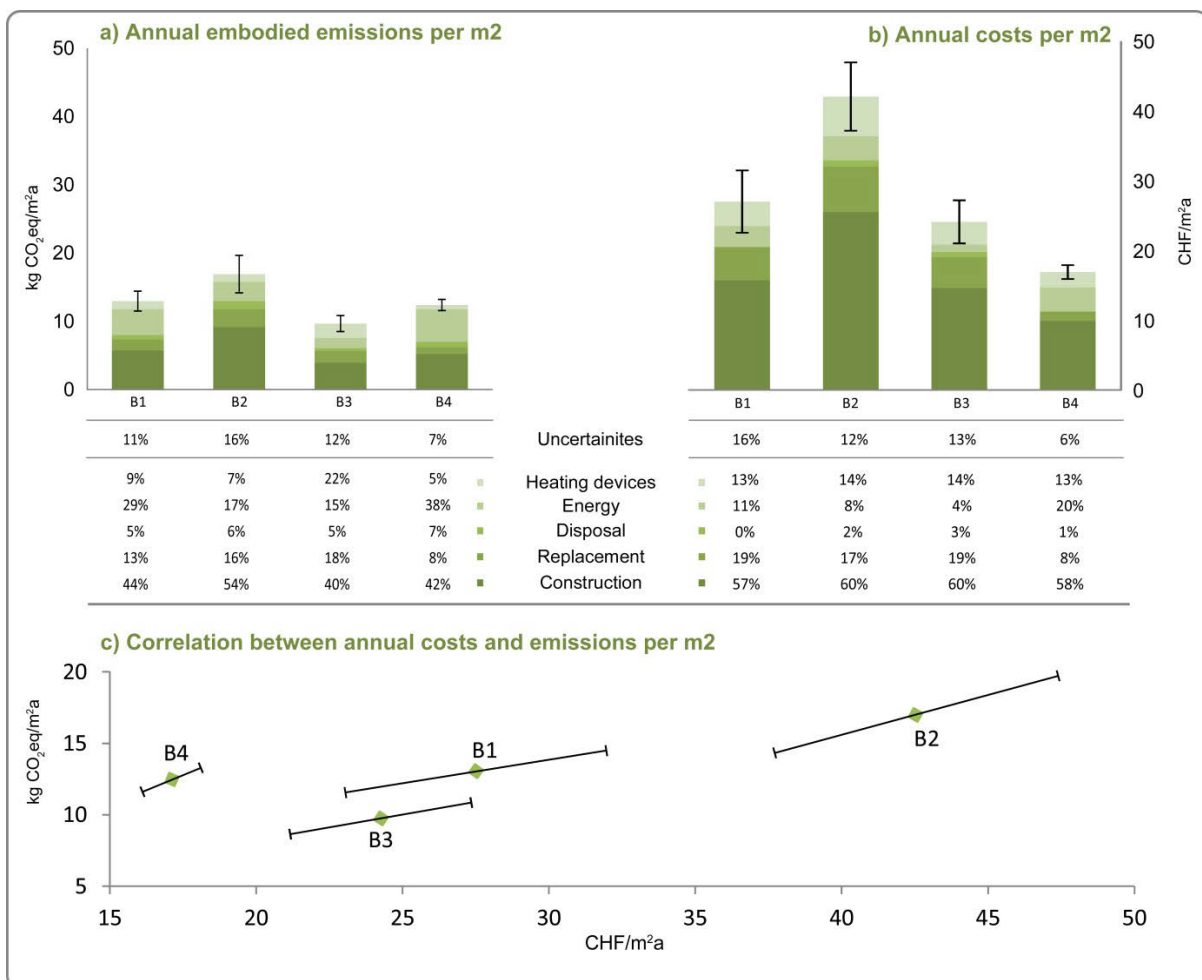

Fig. 4: LCA and LCC for the four buildings with uncertainty. Error bars represent standard deviation ( $\pm 2\sigma$ ).

#### 4 DISCUSSION

This study underlines the importance of the replacement uncertainties arising from SL in the context of increasing energy efficiency of buildings. However, to strengthen those results, the analysis should be carried out more deeply in details at the material scale, as well as by increasing the number of evaluated buildings. Also, one should be careful about the strong variation of the buildings' characteristics and the scattering of the LCA or LCC results.

Finally, there seems to be a correlation between economic and environmental cost; the most environmental friendly building of the sample is also one of the most economical buildings, while being of similar comfort and service. This study may open the discussion on future perspectives in the construction industry by raising the question, if the track we are following at the moment really is the most effective one for new sustainable buildings.

#### 5 ACKNOWLEDGEMENTS

The authors would like to acknowledge the support of the CSTB for the provided database concerning the material service lives uncertainties.

#### 6 REFERENCES

1. UNEP, U.N. (2009). Buildings and Climate Changes: Summary for Decision-Makers. Paris. Nations Environment Programme.
2. EN 15978 (2010). Sustainability of construction works – Assessment of environmental performance of buildings – Calculation method. Brussels. European Committee For Standardization.
3. Ciroth A., Fleischer G. and Steinbach J. (2004). Uncertainty Calculation in Life Cycle Assessments – A Combined Model of Simulation and Approximations. *International Journal of LCA*, 9(4): 216 – 226, doi: 10.1065/lca2004.05.158.
4. Hoxha E., Habert G., Chevalier J., Bazzana M. and Le Roy R. (2014). Method to analyse the contribution of material's sensitivity in buildings' environmental impacts. *Journal of Cleaner Production*, 66: 54-64, doi: 10.1016/j.jclepro.2013.10.056.
5. Arja M., Sauce G. and Souyri B. (2009). External uncertainty factors and LCC : a case study. *Building research & Information*, 37(3): 325-334, doi:10.1080/09613210902863609.
6. Slob W. (1994). Uncertainty Analysis in Multiplicative Models. *Risk Analysis*, 14(4): 571 – 576, doi:10.1111/j.1539-6924.1994.tb00271.x.
7. John V. (2012). Derivation of reliable simplification strategies for the comparative LCA of individual and "typical" newly built Swiss apartment buildings. *ETH Zurich*, doi:10.3929/ethz-a-007607252.
8. Koordinationskonferenz der Bau- und Liegenschaftsorgane der Öffentlichen Bauherren KBOB (2012). *Ökobilanzdaten im Baubereich 2009/1*. Bern. KBOB.
9. Schweizerische Zentralstelle für Baurationalisierung CRB (2012) *LCC Leitfaden – Planung der Lebenszykluskosten*. Zurich. CRB.
10. Koordinationskonferenz der Bau- und Liegenschaftsorgane der Öffentlichen Bauherren KBOB (2012). *Wirtschaftlichkeitsrechnung im Hochbau – Draft version 2014*. Bern. KBOB.
11. Office Fédéral de la Statistique OFS (2012). *La statistique suisse des prix de la construction octobre 2010*. Neuchâtel. OFS.



Zurich, June 15-17 2016

Sustainable Built Environment (SBE) Regional Conference

## Expanding Boundaries: Systems Thinking for the Built Environment



### ENGAGING STAKEHOLDERS THROUGH LOCAL PROJECT COMMITTEES

G. Barbano<sup>1\*</sup>, A. Moro<sup>1</sup><sup>1</sup> iiSBE Italia R&D, via Livorno 60, 10144 Torino, Italy

\*Corresponding author; e-mail: giulia.barbano@iisbeitalia.org

#### Abstract

The EU FP7 project FASUDIR (Friendly and Affordable Urban Districts Retrofitting) was born to develop models and tools to support European building retrofitting market mobilization towards the fulfilment of 2020 and 2050 targets. The key instrument proposed by the project is the Integrated Decision Support Tool (IDST), a software developed to help decision makers to select the best energy retrofitting strategy to increase the sustainability of the whole district. The IDST was conceived to merge a robust modelling and simulation core with a decision making methodology.

However, such a methodology must be validated with the key stakeholders in urban retrofitting, in order to prove effective and respond to the actual needs of the users. Therefore, in order to ensure the development of a usable and effective methodology and tool, the FASUDIR project introduces the concept of Local Project Committees (LPCs), establishing one LPC per partner country (Germany, Hungary, Italy, Spain, UK). The Committees are composed of representatives of different stakeholders (designers, public administration, policy makers, energy providers, researchers, industry, etc) and are convened at each key step of the project to provide their expert advice on advanced draft proposals by the project, before the finalisation of each key output.

This paper will describe the workshop approach and successful experiences carried out during the FASUDIR project, highlighting lessons learnt and best practices to establish efficient research to stakeholder feedback loops, crucial to ensure fruitful dissemination and exploitation of the results beyond the lifetime of the project.

#### Keywords:

Stakeholders; engagement; workshop; participation

### 1 INTRODUCTION

The traditional approach to the building energy efficient retrofitting can bring poor results in relation to the urban sustainability, resource efficiency and economic return. Although the district retrofitting approach is frequently proposed as more sustainable and cost-effective, the complexity of decision making grows exponentially when the intervention targets larger scales, even more when considering the fragmentation of the construction sector.

The FASUDIR project (Friendly and Affordable Sustainable Urban Districts Retrofitting) was born to develop an Integrated Decision Support Methodology and Tool, merging a decision making methodology with a robust modelling and simulation software, which shall support such

complex decisions and help urban planners in defining the optimal energy retrofitting scenario to improve the overall sustainability of the refurbished district, through a structured phases approach featuring variant comparison supported by a suite of tools, including KPI-based decision making and advanced energy analysis tools[1].

The decision to create such a tool came from the specific issues and complexities of urban retrofitting: the long lifetime of the process, the multiplicity of decision makers and the variety of involved stakeholders require an overall approach that is structurally different from building retrofitting. However, a methodology that involves such a diverse amount of expertise cannot be designed in a void and be successful: rather, it requires the implementation of feedback loops in all steps of its development.

Therefore, within the project framework, several meetings have been planned to transfer important market inputs into the FASUDIR Project; at the same time, the collected knowledge of the project is transmitted to the local stakeholders that are the potential end users of the main FASUDIR result, the IDST.

To achieve this objective, in each country (Italy, Spain, Germany, Hungary and UK), project partners have established a Local Project Committee (LPC), which consists of experts and members of the building sector both from the public and private side. The LPCs meet to assess and discuss the status of the project FASUDIR and offer advice. The main purpose is to ensure the development of a software (IDST) that really meets the needs of the stakeholders.

## 2 DATA AND METHODS

### 2.1 Role of the LPCs

The LPCs have been formed by the different stakeholders representative of the potential end users of the IDST, by introducing either expert knowledge or a market perspective, and are developed to act both as a multiplier and an aggregation system. The LPCs provide the vision, needs and expectations of the community of stakeholders that will be the beneficiaries of the project's results.

The main tasks of LPCs in the FASUDIR project are: to provide advice from the end user's point of view on the IDST; to support the organization of local dissemination events; to act as multiplier and aggregation system for stakeholders; to support the IDST in reach its target market; to secure developments of the IDST beyond the project's lifetime.

### 2.2 Establishment of the LPCs

In each country, stakeholders have been invited through existing networks and direct contacts, ad-hoc meetings, and regional conferences. The invited stakeholders cover the whole spectrum of the expertise addressed by FASUDIR, and are the potential end users of the IDST: experts, members of the building sector, and representatives of public organizations.

#### 2.2.1 Stakeholder types

In order to facilitate the invitation process, an initial list of stakeholder types and features was drafted to propose the key expertise set that shall be covered within the LPCs. Such types include:

**Central government:** Characterized by long term policy objectives to reduce carbon emissions, support new technologies, stimulate the economy through the construction sector, improve social welfare.

**Local government and municipalities:** In this category are included the Urban Managers that are interested in increasing the sustainability of

the city and consequently identifying the urban areas that could require and benefit from deep renovation and guiding the neighbours in this process. This stakeholder type is crucial, as regional planning objectives take a systematic view and tend to involve many building and district level sustainability Key Performance Indicators (KPIs), which are at the core of the Integrated Decision Support Methodology developed within FASUDIR.

**Multilateral funding bodies:** These major lending institutions have overall targets to meet in terms of the amount energy efficiency projects and loans to activate. Generally, they act in the field by making funds available to retail banks or special programmes.

**Retail banks:** In order to guarantee funding for retrofitting, in some cases it is necessary to rely on conventional lending structures. However, banks require sound financial plans showing positive returns, adequate debt coverage ratios and a low risk of default. In general, they tend to be more risk averse than the multilateral funding bodies.

**Social housing organizations:** A crucial stakeholder type with a marked interest on improving performance on all three pillars of sustainability, and usually an availability of a portfolio of buildings that is optimally placed to be retrofitted through a district-scale approach. In general, reducing energy costs and improving various housing quality indices are among the most relevant objectives.

**Public sector facilities and commercial users:** Reducing energy costs, understanding revenue potentials, providing stable and sustainable energy, as well as perhaps a "green" image, tend to be important targets for this type of stakeholder.

**Distribution utilities:** The implications of changes in consumption and embedded generation have a significant impact on system planning and infrastructural performance, as well as provide potential opportunities to change tariff schemes and billing.

**Planners, architects:** Another key stakeholder in the process: often local governments and municipalities rely on their technical expertise to manage the overall retrofitting approach in an intervention area. They design and develop the best retrofit actions that concern their constructions/infrastructures. Furthermore, as Technical Staff, they are able to propose the best available solutions (materials, technical installations, etc.) on the market.

**ESCOs, analysts:** Experts with specific knowledge can also be invited to be part of the LPC, focusing on those who hold a deep expertise on urban retrofitting and sustainable building issues. This group includes researchers, academics, members of public building authorities, etc.



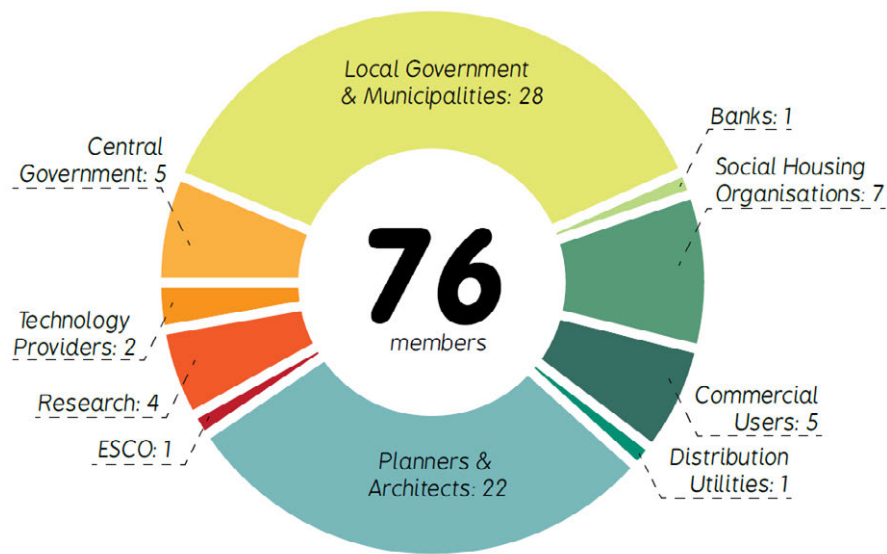

Fig. 1: Stakeholder breakdown by type

### 2.2.2 Stakeholder breakdown

The stakeholders' recruitment process started early in the FASUDIR project life, and has resulted in an overall involvement of 76 representatives across 10 stakeholder types (Fig. 1).

In particular, the two most represented stakeholder types are the Local Governments and Municipalities (36,8%) and the Planners and Architects (28,9%). Furthermore, it is interesting to note that Commercial users and Analysts have both been broken down further to identify two other key stakeholder types, the Technology Providers and the Researchers respectively.

The number of LPC members per country ranges from 6 to 23, ensuring a manageable number of participants during the meetings and fostering a high-engagement atmosphere.

## 2.3 LPC meetings

### 2.3.1 Main objectives

Throughout the life of the project, four LPC meetings have been planned, one at each critical stage of the project: one at the beginning, to get feedback on the expectations from the tool; one when the methodology is defined; one meeting once a beta version of the tool is available to evaluate it; one at the end of the project, to show the system running in real scenarios and present the FASUDIR project achievements.

At the time of writing, the first two meetings have been carried out. The first meeting, on setting expectations, took place in early 2014; the second, on the final draft of the methodology, was carried out in January-February 2015. The third meeting, focused on presenting the beta version of the IDST, is scheduled for April-May 2016.

### 2.3.2 Methodology

The preferred methodology for the organization of an LPC meeting has been a half-day workshop format, divided in two main parts: at the beginning,

the LPC organizer presents the main content of the meeting, both using electronic presentations and supporting paper materials as required; after this initial presentation, the meeting takes a more informal structure, with the organizer leading the participants in an open discussion on the presentation, and aiming to answer a few key questions. In some occasions, it has not been possible to convene the whole LPC for an in-person meeting, substituting with remote conferencing and one-on-one conversations; however, the overall format of presentation and discussion has been maintained in these variants.

Following the meeting, the organizer summarizes the outcomes as minutes according to a common template, in order to record the main results and share them with the other FASUDIR partners.

### 2.3.3 Support materials

In order to make the most of the meetings and ensure a consistent feedback, all workshops have been supported with content developed by the Dissemination and Exploitation Coordinator in cooperation with the project partner leading the developments presented to the LPCs. Such content has been provided in advance to the organizers, in order to allow translations in the local language, if necessary. Furthermore, all LPC organizers have been provided with an agenda template with suggested times, in order to ensure a similar experience across countries. Finally, to guarantee a certain level of homogeneity in the outcomes, the discussion session was supported by a set of key questions and discussion topics which had to be put forward to the LPC members.

## 2.4 Other types of LPC involvement

The LPC members have further been involved throughout the life of the project through informal consultations, such as interviews and questionnaires [2]. Furthermore, LPC members have been kept apprised of all developments

through the project newsletter and targeted invites.

### 3 RESULTS

The first LPC meeting took place on February 2014 and it has been successful in defining the scope of the IDST, focusing on the type of proposed IDST features and highlighting key critical issues. Different types of inputs have been received reflecting the different stakeholders involved in the LPC. Having groups of mixed stakeholders participating in the LPC meeting and not addressing each kind of stakeholder separately showed to be very positive. Profitable discussions arise more easily, and the different points of view enrich the contributions.

FASUDIR is a complex project because of the scale addressed (urban districts) and for the high number of stakeholders addressed. One key objective of the project is the creation of a collaborative platform that should facilitate the interaction between the different stakeholders during the study and implementation of an urban district retrofit. The first LPC meeting allowed to provide the IDST developers with the necessary information to follow in the development of a tool able to answer the user's needs. This is the key success factor of all the research projects targeted to develop new products and software: provide something that will be accepted and requested by the market.

The second meeting has been useful in providing final adjustments to the methodology and confirming the overall approach, structure and understanding of retrofitting process. The meeting was of particular importance because the methodology can be considered the core element of the whole project. The explanation of the methodology has been simplified to be more understandable by participants, in particular the ones without a specific technical or scientific background. Inputs were provided by LPCs concerning the transparency of data and information, the business case and financial calculations, the need for IDST contextualization, how to manage historical buildings, how to make effective the stakeholders' involvement, the need for a user friendly graphic interface.

### 4 DISCUSSION

The main difficulty on LPC setup has been to motivate the stakeholders to participate. The members of an LPC provide voluntary work, they don't receive any financial contribution from the project. In the "recruitment" phase specific benefits have been identified for each kind of stakeholder in the way to raise their interest to be part of the LPC. For instance SMEs and professional can learn about new business possibilities linked to innovative services. Public

administrations can understand the possible support provided by decision making tool in the urban planning activities.

Another problem has been the occasional time availability of stakeholders. This makes it difficult to get repeated engagement, and at times it is necessary to bring new stakeholders on board and thus have different levels of experience with the project within the LPC.

Between the first and the second meeting, the composition of the LPCs has been improved in terms of number of members and type of stakeholders represented. This has been facilitated by the possibility to show the first concrete results of the project and consequently FASUDIR's objectives looked more understandable. Raising interest has been a quite easier task. Other possibilities to stimulate the participation have been explored like the provision of benefits during the exploitation phase or the visibility in FASUDIR outputs.

It has been more easy to access some categories of stakeholders, in particular professionals, SMEs and municipalities. This is due to their direct and active role in urban scale retrofitting processes. It is easier to access these stakeholders also because of contacts and relationships already existing. Other categories of stakeholders, as investors and developers, have been more difficult to access and to involve in LPCs.

### 5 CONCLUSIONS

One of the main problems of any innovative research project is how to efficiently involve the end users. This issue is of particular relevance for the projects that intend to launch on the market new products. It's true that usually the projects produce exploitation plans and activities but these usually come at project's midterm, when at least the concept of the new product has been already developed. The solution provided in FASUDIR to answer this need has been to establish local groups of stakeholders representing the main end users and to involve them since the early phases of the project. In this sense during the first LPC meeting the objectives and scope of the project have been illustrated to verify the need to recalibrate them. The main function of the LPC is to provide directions and advices during the whole project's life, also validating the results, in the way to develop products that fits the expectations of the end users.

After two years of FASUDIR project, the LPC approach showed to be successful and it will be replied in future other projects. The lessons learnt from the FASUDIR experience will be used to improve the efficiency of the LPCs. In particular sources of funding for LPCs should be identified, the occasion when LPC members have to be convened should be further detailed in the project

drafting, the meeting timing should be considered carefully with respects to project progress in order to optimize the stakeholders' time availability and maximize the impact of their feedback.

The LPC method showed to be a very effective networking tool among the local stakeholders that often don't have the possibility to discuss about the topics addressed by the project. LPCs can play a key role after the conclusion of the project by contributing to ensure the durability and transferability of results. Starting from FASUDIR, local national committees have been implemented for the first time. This will facilitate their activation in future projects.

## 6 ACKNOWLEDGMENTS

The research leading to these results has received funding from the European Union Seventh Framework Programme (FP7/2007-2013) under grant agreement n° 609222.

## 7 REFERENCES

1. Mittermeier, P., Eßig, N., Khoja A., Romero, A. A holistic Methodology for District Retrofitting projects management through an Integrated Decision Support Tool, in Sustainable Built Environment Conference 2016 in Hamburg : Strategies, Stakeholders, Success factors, 7th - 11th March 2016 ; Conference Proceedings. 2016: Hamburg, Germany. p. 62-71.
2. Barbano, G., Bunn, D., Camiruaga, I., Eßig, N., Ferrando, V., Kiss, I., Mittermeier, P., Moro, A., Zukowska, E.A., Is it possible to achieve a friendly and affordable urban district retrofitting?, in Proceedings of the World Sustainable Building Conference, Barcelona. 2014: Barcelona, Spain.





## Expanding Boundaries: Systems Thinking for the Built Environment

### MANAGEMENT OF USER AND STAKEHOLDER INTERESTS IN MULTI CRITERIA ASSESSMENTS

H. Kreiner<sup>1\*</sup>, A. Passer<sup>2</sup>

<sup>1</sup> Institute of Technology and Testing of Building Materials - Working Group  
Sustainability Assessment

Graz University of Technology, Austria

\*Corresponding author; e-mail: [helmuth.kreiner@tugraz.at](mailto:helmuth.kreiner@tugraz.at)

#### Abstract

Individual user and stakeholder interests in the context of project requirements and goals often lead to trade-offs; especially during the early design stage of a building. Investors for example strive to achieve a maximum sustainability assessment score on the one hand and optimized initial costs on the other. Users often prefer good indoor environment conditions and low operating costs. A systematic approach is called for in order to achieve both, a high level of stakeholder satisfaction on the one hand and a high performance in the context of sustainability assessment on the other.

We applied a new approach linking building assessment and network analysis based on the Austrian building assessment system (ÖGNI/DGNB) and using a reference project of a public office building in Austria. Giving full consideration to the individual user and stakeholder goals, the determination of sustainability performance is carried out by a scenario analysis taking into account criteria interdependency.

Depending on the investigated scenarios for improvement representing stakeholder influence, the results indicate an optimization potential of ÖGNI/DGNB target achievement between 1.3% and 5.2%.

Systemic influence caused by different optimization strategies on single assessment criteria is an important aspect for the sustainability improvement of buildings. Arising as a result of system trade-offs, inappropriate optimization scenarios – induced by users and stakeholder goals – improve the instantaneously assessed criterion but simultaneously these can lower overall building sustainability. A balanced improvement of all assessment areas is thus indispensable to ensure a high assessment level already in early planning stages and furthermore to achieve stakeholder satisfaction.

#### Keywords:

Systemic Approach; Sustainability Assessment; LCC; LCA; multi criteria design optimization

### 1 INTRODUCTION

During the past few decades various building assessment systems (e.g. LEED (Leadership in energy and environmental design), BREEAM (BRE Environmental Assessment Method) or DGNB (German Sustainable Building Council)) have been established for the assessment of buildings' sustainability. National assessment systems - for example in Austria - are DGNB/ÖGNI (Austrian Green Building Council), ÖGNI/TQ-B (Austrian Sustainable Building Council) and klima:aktiv (building and

refurbishment assessment system). The quality of a building is described by individual assessment criteria in these systems. These criteria are dedicated to different sustainability targets and often related to specific audience groups (depending on the assessment system). In most of the assessment systems the included assessment criteria address more or less similar topics, however the criteria assessment method as well as the weighting algorithms behind the systems are quite different [7]. In the context of the CEN/TC 350 assessment concept, sustainability assessment systems [4] should

cover a broad range of environmental, social and economic aspects as well as functional and technical performance.

A comparison of current assessment systems showed the advantages of DGNB/ÖGNI system in context with the main goals of this study. This assessment concept is in line with the most recent concept of CEN/TC 350 and is even more a performance based approach [14], [15], [21]. This performance-based approach is the foundation for highlighting the quantitative and systemic consequences of stakeholder decisions during the planning process. In other words, achieving a high quality building is closely and strongly related to a balanced improvement of building sustainability taking into account all categories of sustainability assessment.

The current lack in suitable methods for the estimation of change in building sustainability due to stakeholder decisions is often associated with relatively high efforts in early planning phases [14]. Current optimization strategies are thus often based on singular issues disregarding effects of possible criteria interdependencies. [1], [9], [13], [18]. The improvement of building sustainability could not be fully exhausted; in the worst-case scenario building sustainability decreases.

A systemic approach is a requirement in order to ensure implementation of stakeholder decisions next to high sustainability performance of a building. Based on a systemic approach the behaviour of ÖGNI assessment and final energy demand due to variation of several design measures is presented in [14]. In this article the results achieved by stakeholder analyses (represented by scenario analyses of investigated measures in [14]) are presented.

## 2 METHODS

Systemic thinking (i.e. systems engineering, building cybernetic, etc.) is gaining ever more attention – not least in the construction sector – as a result of the increasing complexity caused by multi criteria assessments in the sustainability improvement process of buildings, [6], [12], [20], [22]. Several systemic approaches to identify correlations of sustainability-criteria have been developed and described [2,6,16,17]. Current works covering important aspects in context with systemic building improvement are described in [1], [2], [10], [11], [23].

The studies on multi optimization approaches described show that most of the current methods in hand are only partly suitable for application to holistic building improvement using building assessment systems. They do not permit an optimization approach covering both estimation of optimization scenario influence on overall building sustainability and (varying) stakeholder

objectives by highlighting their system interdependencies.

A new systemic approach to improve the sustainability performance of office buildings in the early design stage is presented in [14] and applied to show the systemic behaviour caused by varying stakeholder interests in context to sustainability assessment.

### 2.1 Systemic approach

The approach defines the quality of building as an open, dynamic system [19]. The term “dynamic” represents life cycle approach; the term “open” is associated with variable stakeholder objectives.

The applied methodological approach for systemic improvement of building performance includes 6 main steps. The identification of ÖGNI assessment criteria role is implemented using the sensitivity model of Vester [20] identifying the “key”-criteria and the different roles of the assessment criteria (step 1). During the planning process knowledge about the influence of single measures on the sustainability performance of building is of key interest. Appropriate construction measures for optimization must be carried out by a prior semi-quantitative assessment of building sustainability based on a reference building (step 2). One the quantitative (results from LCCA (Life Cycle Cost Assessment) and LCA (Life Cycle Assessment)) and qualitative optimization potential and the behaviour of sustainability criteria (from Vester-analysis) are known and established possible optimization measures can be defined (step 3). The identification of systemic influence of each measure is then identified by a subsequent project specific systemic evaluation due to network-analysis (step 4). Finally, after identification of the holistic influence single measures have on building sustainability assessment (step 5) the influence of stakeholder interests is investigated (step 6). The investigated single measures are thus combined to scenarios that fulfil stakeholder goals best possible. Due to understanding the systemic behaviour of single measures possible trade-offs can now be highlighted and considered during the further planning process.

### 2.2 Case Study

The methodological approach has been applied to a case study. The investigated building is part of a renovated building complex in the centre of Graz, owned and operated by the Styrian Landesimmobiliengesellschaft mbH. Tab. 1 provides an overview of the key building parameters (in acc. to [14]).

Parameter	Description
Size	Appr. 2.300 m <sup>2</sup> (gross floor area)
Floors	5+1 / reinforced concrete
Facade	Concrete, bricks, Thermal insulation composite system, double glazing-iso with aluminium frame
Energy certificate	B (39 kWh/m <sup>2</sup> *a) n acc. To standard H5055
S/V-ratio	0,21 [m <sup>-1</sup> ]
HVAC	District heating / Convectors, manual ventilation, hot water supply (ground floor: central; upper floors: instantaneous water heater), no cooling supply with exception of multi-functional room (multi split air conditioning)
Mean U-value	0,565 [W/m <sup>2</sup> *K]

Tab. 1: Key parameter of case study.

The semi quantitative sustainability assessment is based on the building assessment system of ÖGNI (usage type – office and administrative buildings) [16]. Tab. 2 gives a short overview of the sustainability criteria and their weighting as a basis for further investigations.

LCA	Life Cycle Assessment	13,5%
C6	Risks to the local environment	3,4%
C8	Sustainable use of resources / wood	1,1%
C14	Drinking water demand and volume of waste water	2,3%
C15	Space demand	2,3%
LCCA	Building related life-cycle costs	13,5%
C17	Suitability for third-party use	9,0%
C18	Thermal comfort in the winter	1,6%
C19	Thermal comfort in the summer	2,4%
C20	Interior air hygiene	2,4%
C21	Acoustic comfort	0,8%
C22	Visual comfort	2,4%
C23	User control possibilities	1,6%
C24	Quality of outdoor spaces	0,8%
C25	Safety and risk of hazardous incidents	0,8%
C26	Handicapped accessibility	1,6%
C27	Space efficiency	0,8%
C28	Suitability for conversion	1,6%
C29	Public access	1,6%
C30	Bicycling convenience	0,8%
C31	Assurance of design and urban development quality in a competition	2,4%
C32	Percent for art	0,8%
C33	Fire prevention	4,5%
C34	Sound insulation	4,5%
C35	Quality of building envelope with regard to heat and humidity	4,5%
C40	Ease of cleaning and maintenance	4,5%
C42	Ease of dismantling and recycling	4,5%
C43	Quality of project preparation	1,3%
C44	Integral planning	1,3%
C45	Optimization and complexity of planning method	1,3%
C46	Evidence of sustainable aspects in call for and awarding of tenders	0,9%
C47	Creation of conditions for optimal use and management	0,9%
C48	Construction site / construction process	0,9%
C49	Quality of contractors / prequalification	0,9%
C50	Quality assurance for construction	1,3%
C51	Commissioning	1,3%

Tab. 2: Assessment criteria (in acc. to ÖGNI).

A preliminary assessment of the building showed a quantitative optimization potential for construction work areas “Façade” and “Technical Building Services”. Through system analysis criteria C35 and C10/11 (representing primary energy demand as a part of term “LCA” in Tab. 2) has been identified as “systemic suitable criteria” for further optimizations (in acc. to [20]). In a next step, appropriate optimization measures have been identified. In total 25 different variants were analysed and dedicated to the following optimization measures [14]:

- Thermal insulation - facade
- Thermal insulation - roof
- Windows
- Thermal insulation - ceiling above passage
- Lighting
- Ventilation
- Heat generation
- Heat supply
- Hot water
- Cooling
- Shading + glazing
- Power generation

Due to the active and critical system influence [20] of the chosen optimization criteria a project specific network analysis was carried out to identify the chain of causes and effects for the measures described.

### 2.3 Stakeholder Scenarios

Construction measures are combined to different optimization scenarios based on the primary optimization goal of individual stakeholders. Depending on the type of usage (i.e. for investment, for private use or for rent, etc.) and the associated optimization strategy, those indicators are defined that need to be optimized.

Tab. 3 gives a short overview of the investigated scenarios. Scenario 2 represents the reference case (as the case study is built) where no optimization indicator has been dedicated.

Stakeholder scenario	Optimization goal	Performance indicator	Unit
S 1	Short-term return	Initial cost	EUR/m <sup>2</sup>
Case Study (S 2)	-	-	-
S 3	short- to medium-term reduction of operating cost	Heating demand	kWh/m <sup>2</sup>
S 4	short- to medium-term reduction of operating cost incl. Improved comfort	Heating demand	kWh/m <sup>2</sup>
S 5	long-term reduction of energy consumption	Final energy demand	kWh/m <sup>2</sup>
S 6	long-term reduction of environmental impact	LCA performance	%
S 7	long-term reduction of economic impact	LCCA performance	%
S 8	Increase of social performance next to reduction of economic impact	User benefit	%
S 9	Reduction of environmental and economic impact	LCA+LCCA performance	%
S 10	DGNB/ÖGNI performance	DGNB/ÖGNI assessment	%

Tab. 3: Stakeholder scenarios.

### 3 RESULTS

The evaluation of the optimization potential of each scenario is compared to a reference scenario (=scenario 1) which represents minimum requirements in the context to legal energy efficiency standard (see OIB-Richtlinie 6 [17]; HWB\* (Heating demand) and KB\* (Cooling demand)). Also with regard to technical building services, the reference scenario is characterized by the fulfilment of minimum requirements and is therefore designed as “initial cost optimum building”.

Fig. 1 shows the variation of the ÖGNI assessment in the categories LCCA, LCA and ÖGNI overall assessment. In the context of European H2020-targets [8] the results are additionally compared to a possible reduction of final energy demand and related to reference scenario 1.

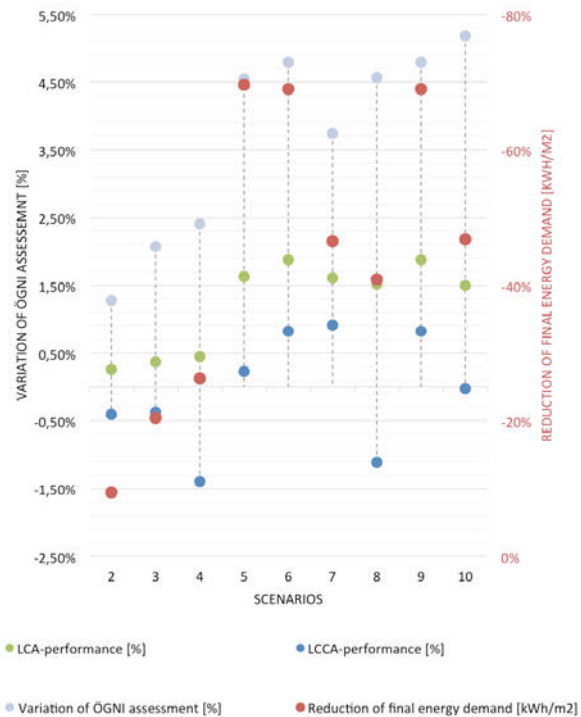

Fig. 1: Influence of stakeholder scenarios on building performance.

In dependence on the optimization strategy, the results show a relative reduction potential of final energy demand from 9.5% to 69.6%. An improvement of 2.2% to 16.2% compared to the reference scenario is possible in the assessment category “LCA” [3], [5]. ÖGNI assessment (representing the term “variation of ÖGNI-assessment” in Fig. 1) can be increased between 0.3% and 1.9%. By contrast LCCA [12, 13] indicates trade-offs (variation from -11.5% to 7.5%). The ÖGNI assessment varies from 1.4% to 0.9% in total.

By considering systemic effects of all criteria based on the investigated strategies and compared to the reference case, the ÖGNI assessment can be improved from 1.3% to 5.2%.

### 4 DISCUSSION

Depending on the primary goals of building performance optimization and in order to manage stakeholder trade-offs in the specific decision making process the results in Fig. 1 are discussed in exemplary form in scenarios 5 and 6 both of which represent public interests. With regard to the European directive 2010/31/EU [8] on the energy performance of buildings scenario 5 represents energy policy objectives (i.e. covering the reduction of final energy demand). By contrast scenario 6 represents environmental policy targets (reduction of global warming, reduction of primary energy demand, etc.) The results show that reduction of final energy demand is in line with improvement of LCCA



performance of the building even in scenario 6. This is due to the implicit consideration of final energy assessment in LCA and the importance of energy impact in the use phase of the building. In this case scenario 6 is recommended for further investigations due to negligible difference between the final energy reduction and the improvement strategies that have been considered. Furthermore, scenario 6 results in a lower initial investment together with a significant reduction of LCC to reach the described optimization targets. The overall assessment almost equals the results for the balanced improvement (see scenario 10). A consideration of the other strategy results shows that any potential improvements from focusing on the parameters “initial cost”, “heating demand” and “customer benefit” are less suitable for implementation in the context of the given stakeholder goals.

The results show, however, that a balanced improvement for highest sustainability performance must not necessarily go hand-in-hand with achievement of the highest energy reduction or the highest reduction of environmental impact. Those decisions with the scenario potential for implementation in practice will at least be based on the willingness of the stakeholders to find a consensus within often complex and specific project conditions.

The advantage of the methodological approach presented is the supporting and managing of multi criteria decisions by providing the systemic and holistic impact of different optimization strategies.

## 5 CONCLUSION

Systemic influence caused by different optimization strategies on single assessment criteria is an important aspect for the sustainability improvement of buildings. Building assessment combined with a systemic approach is an appropriate method for improving building sustainability. Inappropriate optimization scenarios resulting from system trade-offs – induced by stakeholder goals – improve the immediately assessed criterion but simultaneously can lower overall building sustainability. A balanced improvement of all assessment areas is thus indispensable for ensuring a high assessment level already in early planning stages and also for achieving user and stakeholder satisfaction.

## 6 ACKNOWLEDGMENTS

The analysis and results provided here are part of a current research project “UNAB - Sustainable design process & integrated

façades” at Graz University of Technology, Austria. The authors would like to acknowledge all the participants of the UNAB project. A summary and a list with all the members can be found in TUGonline [24]. Finally, the authors are grateful to be financially supported by the Zukunftsfonds Steiermark. and would like to thank the Landesimmobilien-Gesellschaft mbH (Styria) for the provision of the case study data.

## 7 REFERENCES

1. ASADI, SOMAYEH ; AMIRI, SHIDEH SHAMS ; MOTTAHEDI, MOHAMMAD: On the development of multi-linear regression analysis to assess energy consumption in the early stages of building design. In: *Energy and Buildings* Bd. 85 (2014), S. 246–255
2. BASBAGILL, JOHN P. ; FLAGER, FOREST L. ; LEPECH, MICHAEL: A multi-objective feedback approach for evaluating sequential conceptual building design decisions. In: *Automation in Construction* Bd. 45 (2014), S. 136–150
3. CEN: ÖNORM EN ISO 14040 Environmental management - Life cycle assessment - Principles and framework Bd. 2006 (2006)
4. CEN: ÖNORM EN 15643-1 Sustainability of construction works - Assessment of buildings, Part 1: General Framework, ASI (2010)
5. CEN: ÖNORM EN 15978:2012-10-01-*Nachhaltigkeit von Bauwerken - Bewertung der umweltbezogenen Qualität von Gebäuden - Berechnungsmethode*, 2012
6. COLE, RAYMOND J.: Environmental Issues Past, Present & Future: Changing Priorities & Responsibilities for Building Design. In: *SB11 Helsinki*, 2011
7. EBERT, T ; EßIG, N ; HAUSER, G: *Zertifizierungssysteme für Gebäude Nachhaltigkeit bewerten; internationaler Systemvergleich; Zertifizierung und Ökonomie*. Bd. 1. München, 2010 — ISBN 3920034465, 9783920034461
8. EU: *RICHTLINIE 2010/31/EU DES EUROPÄISCHEN PARLAMENTS UND DES RATES vom 19. Mai 2010 über die Gesamtenergieeffizienz von Gebäuden*. Bd. 2010, 2010
9. FRÖCH, GEORG: Sustainability issues in the valuation process of project developments. In: *Energy and Buildings* (2015)
10. GEYER, PHILIPP: Systems modelling for sustainable building design. In: *Advanced Engineering Informatics* Bd. 26 (2012), Nr. 4, S. 656–668

11. HAFNER, ANNETTE: *Wechselwirkung Nachhaltigkeit und ( Bau- ) Qualität – Systemische Betrachtung des Zusammenspiels von Nachhaltigkeitsaspekten und Kriterien der ( Bau- ) Qualität im Sensitivitätsmodell und in der Analyse von beispielhaften Gebäuden* Dissertation : Annette H, TU München, 2011
12. HUNKELER D., LICHTENVORT. K., REBITZER G.: *Environmental Life Cycle Costing*: SETAC, 2008
13. KARIMPOUR, MAHSA ; BELUSKO, MARTIN ; XING, KE ; BRUNO, FRANK: Minimising the life cycle energy of buildings: Review and analysis. In: *Building and Environment* Bd. 73, Elsevier Ltd (2014), S. 106–114
14. KREINER, H. ; PASSER, A. ; WALLBAUM, H.: A new systemic approach to improve the sustainability performance of office buildings in the early design stage. In: *Energy and Buildings* (2015)
15. KREINER, HELMUTH ; PASSER, ALEXANDER: Interdependency of LCCA and LCA in the assessment of buildings. In: *Third International Symposium on Life-Cycle Civil Engineering*: TAYLOR and FRANCIS GROUP, 2012 — ISBN 9780415621267, S. 1794–1801
16. ÖGNI: Kriteriensteckbriefe NBV09 AUT 01 - Stand 2010-03 (2010)
17. ÖSTERREICHISCHES INSTITUT FÜR BAUTECHNIK: OIB-Richtlinie 6-Energieeinsparung und Wärmeschutz (2007)
18. PICCO, MARCO ; LOLLINI, ROBERTO ; MARENGO, MARCO: Towards energy performance evaluation in early stage building design: a simplification methodology for commercial building models. In: *Energy and Buildings*, Elsevier B.V. (2014)
19. SCHALCHER, HANS RUDOLF: Systems Engineering. In: *IBB-Institut für Bauplanung und Baubetrieb* (2008)
20. VESTER, F.: *Die Kunst vernetzt zu Denken-Ideen und Werkzeuge für einen Umgang mit Komplexität*: Deutscher Taschenbuch Verlag, 2008
21. WALLBAUM H. AND HARDZIEWSKI R.: Minergie und die Anderen -- Vergleich von vier Labels. In: *TEC21* Bd. 47 (2011), S. 32–39
22. WILMS, FALKO E.P. ; ET.AL.: *Wirkungsgefüge - Einsatzmöglichkeiten und Grenzen in der Unternehmensführung*: Wilms, Falko, E.P., 2012
23. WITTSTOCK, BASTIAN: *Methode zur Analyse und Beurteilung des Einflusses von Bauprodukteigenschaften auf die Nachhaltigkeitsbewertung im Rahmen der Zertifizierung von Gebäuden*. Stuttgart, Fraunhofer Verlag, 2012
24. UNAB - Sustainable Designprocess & Integrated-Facades  
[https://online.tugraz.at/tug\\_online/fdb\\_detail.ansicht?cvfanr=F34029&cvorgnr=2265&sprache=2](https://online.tugraz.at/tug_online/fdb_detail.ansicht?cvfanr=F34029&cvorgnr=2265&sprache=2)



## Expanding Boundaries: Systems Thinking for the Built Environment

### BUSINESS MODEL INNOVATION FOR LOCAL ENERGY MANAGEMENT: A SYSTEMATIC METHODOLOGY

E.Facchinetti<sup>1\*</sup>, S.Sulzer<sup>1</sup>

<sup>1</sup> Lucerne Competence Center for Energy Research, Lucerne University of Applied Science and Arts, 6048 Horw, Switzerland

\*Corresponding author; e-mail: emanuele.facchinetti@hslu.ch

#### Abstract

The energy market and its actors are currently exposed to a triple challenge: the undergoing market liberalization, an extremely uncertain regulatory framework, and the increasing market penetration of renewable energy. This challenge is expected to provoke a deep reorganisation of the whole energy sectors. Traditional business models operated by utility companies do not guarantee any more competitiveness in the market. Energy market stakeholders are urged to identify the new business opportunities emerging with the energy transition and how to successfully exploit them. In this perspective, business model innovation has been acknowledged as of strategic importance for the successful deployment of the energy transition. This work contributes to this topic by introducing a systematic approach for the identification, development and assessment of innovative business models tailored on Local Energy Management concepts.

#### Keywords:

Local Energy Management; Energy Hub; Business models; Business innovation; Distributed generation; Renewable energy

## 1 INTRODUCTION

The first universal legally binding agreement on climate change recently signed in Paris represents a bridge between in force policies and the objective of climate neutrality by the end of the century [1]. This transition towards a more sustainable and decarbonized global energy system requires a deep reorganization of the energy sector.

The energy market and its actors are currently exposed to a triple challenge [2]: the undergoing market liberalization, an extremely uncertain regulatory framework, and the increasing market penetration of distributed generation.

As a consequence, a term, the energy supply value chain is expected to be deeply impacted [3]. Currently the main actors of the sector, utility companies, are losing market competitiveness and profitability and strive to find appropriate solutions to adapt to the undergoing transition [4] [5]. Many amongst the largest European utilities, among others the German E.ON [6], RWE [7] and EnBW [8], the French EDF [9], the Italian

ENEL [10] and the Swiss REPOWER [11], in the last months announced important reorientations of their activities due to the fact that traditional business models do not allow any more to be competitive in the market. The creation of innovative business models is required to exploit the new business opportunities arising with the energy transition[3], [5].

Recently, several scientific works highlighted the emerging major role of business model innovation in supporting the radical change in value proposition and value creation logic required to promote sustainability [12], [13]. In particular, a restricted number of contributions specifically has recently focused on business model innovation within the energy sector. Look [14] investigated through choice experiments with investment managers the business models that could favour the market penetration of renewable energy. Richter [15] compared the currently used business models for renewable energy and outlined how utilities should invest in business model innovation to increase their

competitiveness. The same author [16], analysing the German case, outlined as utilities tend to fail perceiving photovoltaic based distributed generation as new business opportunities and posited as business model innovation could take advantage by being addressed by newly created entities, external to the main utility company, such as spin off.

However, available research is lacking in the identification of tailored general business models potentially applicable to the energy transition. In this regard, recently the authors [17] [18] introduced a conceptual framework easing the identification of business model patterns best suited for Local Energy Management concepts (LEM) - the management of energy supply, demand and storage within a given geographical area. Building upon this conceptual framework, this work presents a systematic methodology for the identification, development and assessment of business models tailored on LEM concepts.

The paper is organized as follows. In the second section the analytical framework is delineated. Afterwards the proposed methodology is presented and discussed. Finally, in section 4 the conclusions are outlined.

## 2 ANALYTICAL FRAMEWORK

In this section the analytical framework supporting the methodology described in the next section is defined. In particular, the definition of Local Energy Management and business model concepts considered by the authors are outlined.

### 2.1 Local Energy Management

Local Energy Management, depicted in *Fig. 1*, can be concisely defined as the management of energy supply, demand and storage within a given geographical area [17]. Purely considering the energy services perspective, the Local Energy Management is an entity guaranteeing, within a limited geographical area and for multiple energy carriers, the energy supply to meet the demand through the optimized management of internal flexibilities and energy market participation. Considering the market perspective, the Local Energy Management is a business, potentially ran by utilities, aggregators, ESCOs or public bodies, connecting consumers, prosumers, and partners (i.e. neighbour Local Energy Management, industry, utilities) to each other and with the wholesale energy market [17]. The value chain of a Local Energy Management can be summarised in 5 steps: the acquisition of customers and partners; the procurement of the infrastructures required to generate and managed the energy services; the operation and control of said infrastructures; the delivery of the energy services; and finally the pricing of said services to customers and partners.

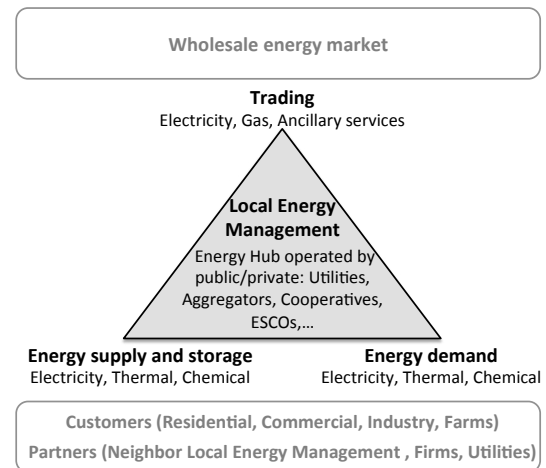

*Fig. 1: Local Energy Management concept [17].*

### 2.2 Business models

Business models are attracting more and more interest from the scientific literature. No univocal accepted definition exists. Instead many authors provided general and compatible definitions. Two common coherent definitions widely used in the literature and in particular applied to the energy sector [15], [17], [19] are the one proposed by Gassmann et al. [20], who define the business model as "a unit of analysis to describe how the business of a firm works"; and Osterwalder et al. [21], who define it as "the rationale of how an organization creates, delivers, and captures value". Many of the existing definitions, and in particular the ones proposed above, rely on four key elements to fully characterise a business model. Following the naming proposed by Osterwalder et al. [21] these elements are: the value proposition, describing what is offered to the customers; the customer interface, including the characterisation of the target customers; the infrastructures, including all means needed to deliver the value proposition; and finally the revenue streams, explaining how profit is generated.

The flourishing literature on business models feeds the research on business model innovation. Business model innovation is framed in the literature as a discipline supporting the change of value proposition to a customer [13], generally involving the change of the way a business is ran [22], and considering a large number of stakeholders and a broad value-network going well beyond the existing firm perspective [22], [23]. In particular, several works targeted business model innovation for sustainability, which focus on maximising not only economic profit but also societal and environment gains [12], [13], [24]. Recently a comprehensive literature review on this topic has been performed by Bocken et al. [13] to derive a number of business model archetypes promoting sustainability.

The authors contributed to the topic of business model innovation for sustainability with the development of a conceptual framework supporting business model innovation for Local Energy Management concepts [17], [18].

### 3 RESULTS AND DISCUSSION

Based on previous scientific works [17] [18] and as a result of the experience acquired in business innovation related collaborations with industrial partners (i.e. mainly including utility companies), a systematic methodology addressing the business model innovation for Local Energy Management has been developed and it is presented hereafter.

The objective of the methodology is to systematically guide potential Local Energy Management stakeholders through the business model innovation process. In particular, the methodology aims on the one hand to enable the assessment of new business opportunities with respect to their market penetration potential; and on the other hand to support the creation of tailored business model concepts considering in an holistic perspective technology, economic and social aspects. The methodology is depicted in its six steps in Figure 2.

#### I. Identify the intended concept

At first, the intended Local Energy Management concept must be identified. In particular, the intended business idea must be generally delineated with respect to the four key features characterising a business model presented above [21]: the value proposition, the customer interface, the infrastructures, and the revenue streams. Within this step, Stakeholders Analysis and Customer's Pains and Gains Analysis (Osterwalder and Pigneur, Y., 2010) are performed to highlight opportunities and barriers related to the intended concept.

#### II. Intended concept characterisation

Within the second step the intended concept is systematically characterized with respect to general main determinants defined in a previous work [18] including technical aspects related to the intended Local Energy Management typology, customer socio-demographic aspects, macro-economy and regulatory frameworks related aspects.

The characterisation through general predefined determinants enables to associate the indented concept with the most appropriate portion of the conceptual business model solution space for Local Energy Management defined in a previous work [17].

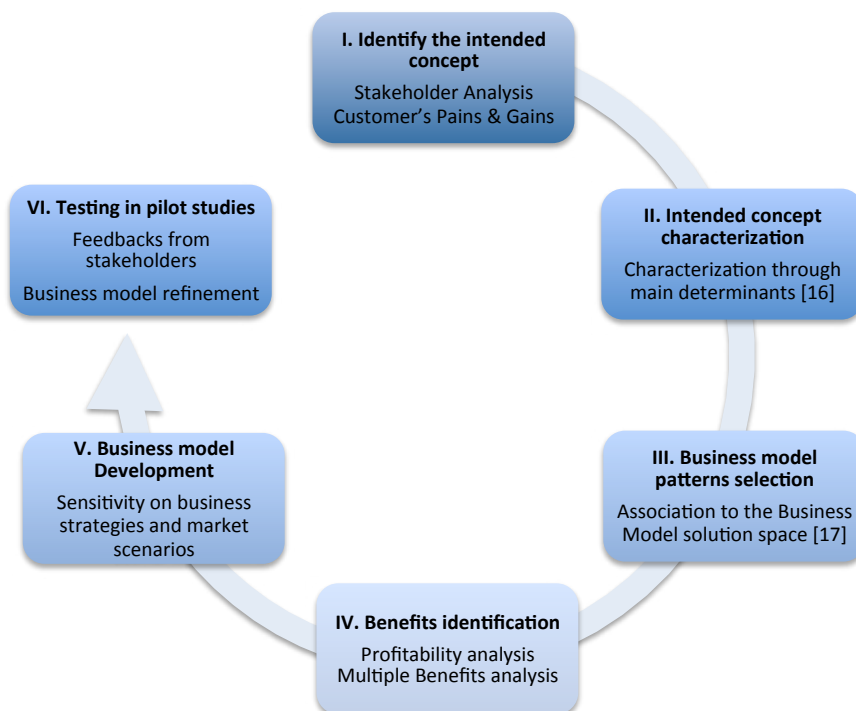

Fig. 2: The systematic methodology for Local Energy Management Business Model Innovation.

### III. Business model pattern selection

The conceptual framework defining the business model solution space [17], comprehensively organises in a structured way the general business model patterns potentially applicable to Local Energy Management. Associating the main determinants characterised in the previous step to the business model solution space, the general business model patterns that are most appropriate to the intended concept can be identified. Each pattern refers to a certain region of the solution space and includes a number of basic business model ideas organised with respect to the Local Energy Management value chain step. The combination of the identified business model ideas is used in step V to create specific business models.

### IV. Benefits identification

Within this step, the benefits obtainable from the intended concept are assessed. The benefits are distinguished in two different main categories: the ones directly and the ones indirectly associated to economic profitability.

The benefits belonging to the first category are assessed through the combination of:

- thermo-economic analyses, investigating the trade-off between energy efficiency performance and investment/operating costs of the energy conversion, storage and grid infrastructures required by the intended concept;
- and profitability analyses estimating the value that the intended concept can potentially create within the retail (i.e. the market value of the services provided to the customers) and wholesale energy markets (i.e. the market value obtainable from the valorisation of the internal flexibilities).

The full added value potential of an intended concept must also include all benefits not directly associable to economic profitability. In the scientific literature these benefits are often referred to as multiple benefits or co-benefits [25]. In the Local Energy Management perspectives, multiple benefits analysis aims to capture and assess all additional benefits facilitating the achievement of the objectives of the different involved stakeholders [25], including for instance: emission reduction, improved energy security, improved local air pollution, creation of local employments, avoidance high voltage electricity transmission lines, etc.

The comprehensive assessment of all potential benefits enables to spot all the value creation opportunities associated to the intended concept.

### V. Business model development

Combining the information on the business model strategies most suitable to the intended concept (outcome of step III) with the understanding on where and how value is created (outcome of step

IV), within step V a range of specific business models tailored on the intended Local Energy Management concept can be designed.

The range of developed business models should address different strategies (i.e. considering several business model archetypes based on the selection performed in step III) and multiple future market scenarios. The direct involvement of a variety of stakeholders is crucial at this stage to capture their preferences through behavioural/preference surveys. This step should lead to the selection of a restricted number of promising business models to be tested in pilot experiments.

### VI. Business model development

The final step of the methodology focuses on the implementation in pilot experiments of the newly developed business models. The testing in pilot experiments prior the market implementation is considered essential to validate new business models and refine them based on the feedbacks collected directly in the field from the involved stakeholders [20] [21]. Furthermore, from the pilot experiments useful insights can be derived to define the most appropriate market implementation strategy.

The presented methodology is kept in continuous refinement and evolution through the integration of new analysis approaches as well as the knowledge continuously acquired from stakeholder's preferences investigations.

## 4 CONCLUSIONS

Business model innovation emerges as a key driver towards the reorganisation of the energy market required to achieve the ambitious goals of the undergoing energy transition. The present work contributes to this topic proposing a systematic methodology for the business model innovation of Local Energy Management - the management of energy supply, demand and storage within a given geographical area. The presented methodology has been developed based on the outcomes of previous scientific works in this topic and on the experience acquired through business innovation projects carried out in collaboration with industry partners. The six steps methodology aims to support potential stakeholders in a systematic way through the business model innovation process: from the identification and the assessment to the business model development and testing of Local Energy Management related business opportunities.

## 5 ACKNOWLEDGMENTS

This work has been accomplished in the frame of the Swiss Competence Center for Energy

Research on Future Energy Efficient Buildings & Districts SCCER FEEB&D, funded by The Commission for Technology and Innovation of the Swiss Confederation.

## 6 REFERENCES

1. UN. UN Climate Change Conference Paris 2015 2015. <http://www.un.org/sustainabledevelopment/cop21/> (accessed December 12, 2015).
2. IEA. World Energy Outlook 2014. 2014.
3. Schleicher-Tappeser R. How renewables will change electricity markets in the next five years. *Energy Policy* 2012;48:64–75. doi:10.1016/j.enpol.2012.04.042.
4. Sühlsen K, Hisschemöller M. Lobbying the “Energiewende”. Assessing the effectiveness of strategies to promote the renewable energy business in Germany. *Energy Policy* 2014;69:316–25. doi:10.1016/j.enpol.2014.02.018.
5. Fratzscher S. The Future of Utilities: Extinction or Re-Invention? A Transatlantic Perspective. Heinrich Böll Stift 2015.
6. E.ON. New corporate strategy: E.ON to focus on renewables, distribution networks, and customer solutions and to spin off the majority of a new, publicly listed company specializing in power generation, global energy trading, and exploration and p. Press Release 2014. <http://www.eon.com/content/eon-com/en/media/news/press-releases/2014/11/30/new-corporate-strategy-eon-to-focus-on-renewables-distribution-networks-and-customer-solutions-and-to-spin-off-the-majority-of-a-new-publicly-listed-company-specializing-in-power-g> (accessed November 30, 2014).
7. RWE. RWE launches future-oriented business with new subsidiary. Press Release 2016. <http://www.rwe.com/web/cms/en/113648/rwe/press-news/press-release/?pmid=4014734> (accessed March 31, 2016).
8. EnBW. EnBW launches new strategic orientation. Press Release 2013. [https://www.enbw.com/company/press/press-releases/press-release-details\\_36928.html](https://www.enbw.com/company/press/press-releases/press-release-details_36928.html) (accessed June 17, 2013).
9. EDF. The renewable energy development strategy of the EDF Group. Press Release 2015. <https://www.edf.fr/en/the-edf-group/dedicated-sections/press/all-press-folders/the-renewable-energy-development-strategy-of-the-edf-group> (accessed November 26, 2015).
10. ENEL. ENEL CEO Francesco Starace announces new sustainable development commitment at UN summit. Press Release 2015. [https://servizi.enel.it/eWCM/salastampa/comunicati\\_eng/1664486-1\\_PDF-1.pdf](https://servizi.enel.it/eWCM/salastampa/comunicati_eng/1664486-1_PDF-1.pdf) (accessed September 28, 2015).
11. REPOWER. Repower positions itself for the future. Press Release 2015. <http://www.repower.com/group/media-investors/media/news-releases/repower-positions-itself-for-the-future-1009/> (accessed December 18, 2015).
12. Schulte UG. New business models for a radical change in resource efficiency. *Environ Innov Soc Transitions* 2013;9:43–7. doi:10.1016/j.eist.2013.09.006.
13. Bocken NMP, Short SW, Rana P, Evans S. A literature and practice review to develop sustainable business model archetypes. *J Clean Prod* 2014;65:42–56. doi:10.1016/j.jclepro.2013.11.039.
14. Look M. Going beyond best technology and lowest price: on renewable energy investors’ preference for service-driven business models. *Energy Policy* 2012;40:21–7. doi:10.1016/j.enpol.2010.06.059.
15. Richter M. Utilities’ business models for renewable energy: A review. *Renew Sustain Energy Rev* 2012;16:2483–93. doi:10.1016/j.rser.2012.01.072.
16. Richter M. German utilities and distributed PV: How to overcome barriers to business model innovation. *Renew Energy* 2013;55:456–66. doi:10.1016/j.renene.2012.12.052.
17. Facchinetti E, Sulzer S. General business model patterns for Local Energy Management concepts. *Front Energy Res* 2016. doi:10.3389/fenrg.2016.00007.
18. Facchinetti E, Eid C, Bolliger A, Sulzer S. Business model innovation for Local Energy Management: a perspective from Swiss utilities. *Submitt to Environ Innov Soc Transitions* 2016.
19. Okkonen L, Suhonen N. Business models of heat entrepreneurship in Finland. *Energy Policy* 2010;38:3443–52. doi:10.1016/j.enpol.2010.02.018.
20. Gassmann, O., Frankenberger, K., Csik M. *The Business Model Navigator*. FT press; 2014.
21. Osterwalder A, Pigneur, Y. *Business Model Generation: A Handbook for Visionaries, Game Changers, and Challengers*. vol. 5. Hoboken NJ: Wiley; 2010.
22. Zott C, Amit R. The business model: A theoretically anchored robust construct for strategic analysis. *Strateg Organ* 2013;11:403–11. doi:10.1177/1476127013510466.

23. Beattie V, Smith SJ. Value creation and business models: Refocusing the intellectual capital debate. *Br Account Rev* 2013;45:243–54. doi:10.1016/j.bar.2013.06.001.
24. Bocken NMP, Short SW. Towards a sufficiency-driven business model: Experiences and opportunities. *Environ Innov Soc Transitions* 2015. doi:10.1016/j.eist.2015.07.010.
25. IEA. *The Multiple Benefits of Energy Efficiency: Measuring the Positive Impacts*. 2014.



Zurich, June 15-17 2016

Sustainable Built Environment (SBE) Regional Conference

## Expanding Boundaries: Systems Thinking for the Built Environment



### ESTABLISHING LINKS FOR THE PLANNING OF SUSTAINABLE DISTRICTS

S. Cajot<sup>1,2,†\*</sup>, N. Schüler<sup>2,†\*</sup>, M. Peter<sup>1</sup>, J. Page<sup>3</sup>, A. Koch<sup>1</sup>, F. Maréchal<sup>2</sup>

<sup>1</sup> European Institute for Energy Research, Karlsruhe 76131, Germany

<sup>2</sup> Industrial Process and Energy Systems Engineering Group, École Polytechnique Fédérale de Lausanne, Lausanne 1015, Switzerland

<sup>3</sup> Institut Systèmes Industriels, HES-SO Valais-Wallis, Sion 1950, Switzerland

<sup>†</sup>These authors contributed equally to this work.

\*Corresponding authors; e-mails: cajot@eifer.org, nils.schueler@epfl.ch

#### Abstract

Cities can play a key role in mitigating climate change impacts, as they represent two thirds of the world's energy consumption and greenhouse gas emissions. This paper presents a model-based approach to support cities in the challenge of including energy issues in early stage urban planning. Recognizing that successful planning must rely on highly integrated solutions, this paper aims, through its approach, to better understand and reinforce links between generally fragmented sectors, scales, stages and disciplines.

Considering the planning framework of the Swiss canton of Geneva, the main planning instruments are presented and an in-depth analysis of the urban and energetic goals and constraints is carried out. Linking the disciplines of planning and optimization, a Mixed Integer Linear Programming (MILP) model is formulated to identify optimal energy strategies, as well as to provide insights into the urban layout, distribution and size of buildings. Additionally, this approach aims to overcome one of the difficulties of early stage planning, where information regarding energy is scarce. In this regard the proposed methodology generates building information based on available data and constraints. The simultaneous consideration of multiple scales allows to assess the interactions of building scale decisions with overall district energy supply alternatives. The resulting depiction and quantification of trade-offs should allow planners to anticipate optimal energy system configurations and adapt their plans accordingly.

#### Keywords:

urban planning; urban energy system; multi-scale; optimization; renewable energy

## 1 INTRODUCTION

### 1.1 Context

According to the International Energy Agency, cities represent two thirds of the world's energy consumption and greenhouse gas emissions, considerably increasing the effects of climate change [1]. Urban actors are therefore key in reducing overall impacts from cities, in particular by focusing on the building sector. Indeed, in the European context, 40% of the total final energy consumption is from buildings [2]. Urban planners

have a significant part to play in the challenge of developing low carbon cities, as one of their main tasks is that of a mediator: to coordinate multiple actors and balance a wide range of often conflicting interests [3, 4]. Historically guided mainly by socio-economic values, current urban planning must as well consider eco-system sustainability [4, 5]. Previous works revealed that considering the energy supply system just in a second step could lead to worse system designs [6, 7].

## 1.2 Goals of this work

First, within the context introduced above, this paper presents a model-based approach to provide support in the challenge of early stage local urban planning. Considering the planning framework of the Swiss canton of Geneva, an in-depth analysis of the main urban and energetic goals and constraints was carried out. Reflecting as closely as possible this context, though with the aim of extending and generalizing its use to other cities, a Mixed Integer Linear Programming (MILP) model is formulated and applied to identify optimal energy strategies, as well as to provide insights into the urban layout, distribution and size of buildings.

Second, realizing that successful planning must rely on highly integrated solutions, this paper aims, through its approach, to better understand and reinforce links between generally fragmented areas:

- The first link is sectorial and concerns the need for effective methodologies which bridge energy planning requirements with urban planning frameworks [8, 9].
- The second link is between scales. The reliability of planning is increased by recognizing that decisions both on district and building scale mutually depend on each other [6, 10, 11].
- The third link is more practical, dealing with a dichotomy between the strategic phase of planning where uncertainty is high and available information scarce, with the subsequent operational phase which requires and contains more detailed, quantifiable information [12].
- The fourth link is between two disciplines, planning and mathematical programming. The application of the latter may provide highly valuable practical outcomes for planners, but require a fine understanding of the existing planning context and challenges [13].

## 2 MATERIALS AND METHODS

To achieve the goals stated above, a methodology was adopted, which combines the synthesis of key planning documents and discussions with planners, with the simultaneous development of a MILP model (Fig. 1). The workflow begins with a general question, which can be redefined according to insights provided by the outcomes of the optimization phase.

### 2.1 Planning framework synthesis

#### *Description of case-study*

The proposed approach was applied to a green-field urban development site located in Geneva. Originally identified over a decade ago as a suitable urban development site, a rural zone has been modified in 2011 to receive a mixed-use district, including residential, office, commercial and public buildings.

Regarding energy, the project aims to meet the 2000 watts society targets, which includes covering 75% of energy supply with renewable energy sources (RES) [14]. In addition, it is envisaged to become a positive energy district, by exploiting in priority local resources, as well as synergies between activities. The main energy strategies considered in preliminary studies involve geothermal, photovoltaic (PV), and waste heat recovery from the neighboring industrial zone.

#### *Planning framework description*

Urban planning can be defined as a tool to ensure a coherent development of the urban space by public action [15]. It is a process which brings together multiple actors from different sectors, connects different scales and administrative levels and seeks to anticipate long-term social, economic and environmental requirements. In practice, planning relies on the use of multiple,

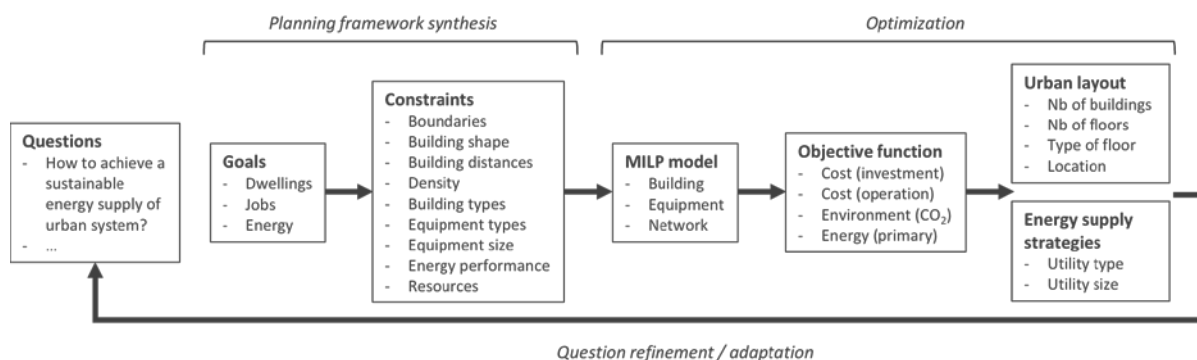

Fig. 1: Adopted workflow.

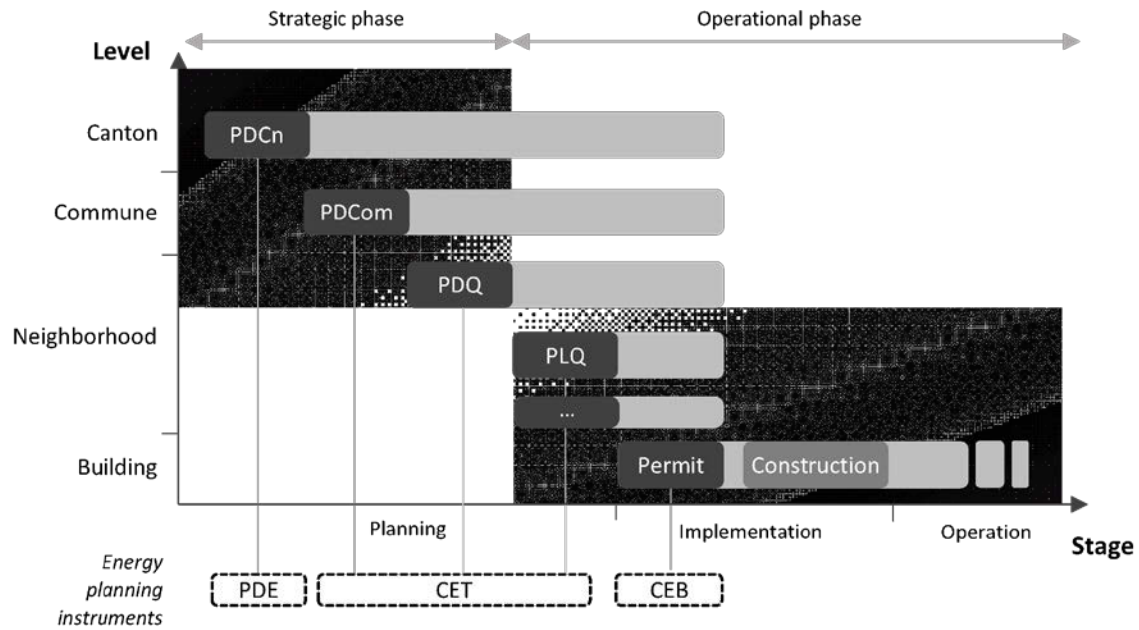

Fig. 2: Main planning phases and instruments applied to the Geneva context (see Table 1 for abbreviations).

interacting instruments [16]. These instruments span temporally across different stages, and vertically across different administrative levels. Based on typical planning stages identified by [17] and on the multiple planning levels, the main instruments involved in an urban development project were mapped across these two axes (Fig. 2). This process can be divided in two phases, in which instruments serve either a strategic function, or an operational one. We use the term strategic as relating to “a careful plan or method for achieving a particular goal, usually over a long period of time” [18], and operational as in “ready for use” [19]. The strategic phase indeed includes plans and documents which identify long-term goals in a broad range of fields, as well as different possible alternatives. The operational phase extends the general strategies identified in the initial plans, providing local details on the layout of the urban area (e.g. location and size of buildings, infrastructure, public equipment, etc.). The resulting physical plans then lead to building authorizations, construction and, eventually, monitoring, serving for the elaboration of the future strategic plans.

Due to evolutions in the scope of urban planning, which today tends to include the many facets of sustainability [4, 5, 15, 16], the topic of energy is generally present in master plans. However, the extent of its influence on the process, and the methodologies with which it integrates urban planning, if any, are very context specific. The methodology proposed in this paper thus contributes to deepen the understanding of possible synergies between urban and energy

planning at the local level. Indeed, as can be observed on Fig. 2, the ‘tipping point’ between strategic and operational phases occurs at the neighborhood scale. The dichotomy between the formulation of strategies and the process of their implementation was furthermore identified as a main obstacle for sustainable planning [12]. Regarding energy issues, one of the challenges at this point is to identify and assess meaningful alternatives in spite of missing or incomplete information on buildings or public equipment. Modeling approaches can therefore help planners by providing relevant information, and is a main focus of the paper.

#### *Review of legal and planning documents*

To take into account the existing goals and constraints which ultimately influence the development of the considered urban development project, several legal and guiding documents have been reviewed (Table 1). The main urban constraints included density, building heights and minimum distances. Regarding energy, constraints of interest included general efficiency and RES goals, building energy performance requirements and available resources. The information gained in this step could be used to construct the model accordingly. Because the Cherpines project is still in the strategic planning phase, the localized neighborhood plan (PLQ), as well as the building permits and energy concepts (CEB) were not considered.

Name	Type	Description
LGZD	Cantonal law	Development zone law (Loi générale sur les zones de développement du 29 juin 1957)
LCI	Cantonal law	Construction and installation law (Loi sur les constructions et les installations diverses du 14 avril 1988)
RCI	Cantonal regulation	Regulation on the construction and installation law (Règlement d'application de la loi sur les constructions et les installations diverses du 27 février 1978)
LEN	Cantonal law	Energy law (Loi sur l'énergie du 18 septembre 1986)
REN	Cantonal regulation	Regulation on the energy law (Règlement d'application de la loi sur l'énergien du 31 août 1988)
OPB	National ordinance	Ordinance on noise protection (Ordonnance du 15 décembre 1986 sur la protection contre le bruit)
LaLAT	Cantonal law	Application of the federal spatial planning law (Loi d'application de la loi fédérale sur l'aménagement du territoire du 4 juin 1987)
LAT	National law	Spatial planning law (Loi fédérale sur l'aménagement du territoire du 22 juin 1979)
SIA-norms	Norm	Set of standards and requirements for planning and construction in Switzerland. (Société Suisse des ingénieurs et architectes).
PDCn 2030	Cantonal directive plan	Document which coordinates confederation, cantons, and surrounding regions. It sets strategic goals as well as measures to reach them. (PDCn – Plan directeur cantonal).
PDCom Plan-les-Ouates (2009)	Communal directive plan	Document providing a global vision of a commune's development over 10-15 years, coordinating with canton and neighboring communes. Contains a concept and synthesis map, as well as measures to reach the objectives. (PDCom – Plan directeur communal).
PDCom Confignon (2006)	Communal directive plan	Document providing a global vision of a commune's development over 10-15 years, coordinating with canton and neighboring communes. Contains a concept and synthesis map, as well as measures to reach the objectives. (PDCom – Plan directeur communal).
PDQ Les Cherpines (2013)	Neighborhood directive plan	Document depicting a future neighborhood in the mid-term. Sets the projects principles, but not the details of layout and construction. Contains layout alternatives, objectives and synthetic map, as well as measures to reach objectives. (PDQ – Plan directeur de quartier).
PDE	Energy directive plan	Document which sets the energy policy goals on the canton level, and establishes desired shares of energy resources, including RES. (PDE – Plan directeur de l'énergie).
CET Secteur des Cherpines (2011)	Territorial energy concept	Approach and document on the territorial scale which organizes and coordinates actors to reduce energy needs by developing energy efficient infrastructure and promoting the use of local energy sources. (CET – Concept énergétique territorial).

Table 1: Main reviewed legal and planning documents.

## 2.2 Optimization model

Simultaneously to the synthesis of the planning framework, and mutually dependent on it, the second part of the adopted workflow consists in optimization to provide answers to identified

questions (Fig. 1). A computational framework for modelling and optimization of energy systems (OSMOSE) was extended to meet urban specific requirements (e.g. Geographic information system (GIS) interfacing). Within this framework an

object-oriented model of urban energy systems was developed which serves to instantiate MILP models for buildings, utilities and networks.

### Buildings

The overall density is defined as the sum of floor areas  $A_{fl}$  of all buildings per net buildable area of the entire district  $A_{nb}$ .

$$ID = \frac{\sum^b \sum^c A_{fl}^{b,c}}{A_{nb}}$$

In order to achieve a specified density, the sum of floor areas over all buildings per usage is constrained by a minimum total floor area per usage :

$$\sum^b A_{fl}^{b,c} \geq A_{fl,min}^c \quad \forall c \in C$$

The floor area per building and usage results from footprint and number of floors per usage:

$$A_{fl}^{b,c} = n_{fl}^{b,c} \cdot A_{fp} \quad \forall b \in B, c \in C: c \neq res$$

$$A_{fl}^{b,c} = (n_{fl}^{b,c} + n_{fl,extra}^{b,c}) \cdot A_{fp} \quad \forall b \in B, c \in C: c = res$$

According to the law, to promote the development of dwellings, the building height limit can be increased, if this floor is used for residential purposes (LCI, Table 1). In order to account for mixed used buildings, this constraint is slightly adapted so as to allow extra floors only for buildings which dedicate at least half of the floors to residential purposes:

$$n_{fl,extra}^b \leq n_{fl}^{b,c=res} / 2 \quad \forall b \in B$$

The number of floors is limited by the permissible building height:

$$\begin{aligned} \sum^c n_{fl}^{b,c} \cdot h_{fl}^c + n_{fl,extra}^b \cdot h_{fl}^{c=res} \\ \leq h_{b,max} + n_{fl,extra}^b \cdot h_{b,extra} \quad \forall b \in B \end{aligned}$$

The floor height per usage is assumed as the average specific floor height for the existing building stock of Geneva [20].

To calculate annual energy demands and design heating power the area-specific values defined by the MINERGIE-P norm [21] were used (Table 2).

floor usage	annual heat demand	annual electricity demand	design heating power
	$q$	$e$	$\dot{q}$
	(kWh/m <sup>2</sup> /y)	(kWh/m <sup>2</sup> /y)	(W/m <sup>2</sup> )
residential	30	25	10
office	25	22.2	10

Table 2: Specific energy demand according to MINERGIE-P norm.

The annual heat and electricity demand per building are thus:

$$Q^b = \sum^c A_{fl}^{b,c} \cdot q^c \quad \forall b \in B$$

$$E^b = \sum^c A_{fl}^{b,c} \cdot e^c \quad \forall b \in B$$

The norms just specify design heating power requirements, but not the according values for electricity. Therefore the design heating power is calculated as:

$$\dot{Q}^{b,t=1} = \sum^c A_{fl}^{b,c} \cdot \dot{q}_{design}^c \quad \forall b \in B$$

A second time step is introduced in order to account for the annual heat demand where the heating power requirement is:

$$\dot{Q}^{b,t=2} = \frac{Q^b - \dot{Q}^{b,t=1} \cdot D^{t=1}}{D^{t=2}} \quad \forall b \in B$$

with  $D^{t=1} = 1h$  and  $D^{t=2} = 8759h$ . Likewise the electric power requirement for all time steps is:

$$\dot{E}^{b,t} = \frac{E^b}{\sum^t D^t} \quad \forall b \in B, t \in T$$

Having these two time steps allows designing the system according to maximum heating requirements and thus having a fair representation of investment costs while also calculating annual operation costs correctly. For electricity needs the sizing step is not as important because at the current state it is assumed that the cantonal/national electricity grid is able to balance any surplus or shortcomings of electricity.

In order to locate the buildings the net buildable area is divided into a regular grid of quadratic cells (see section 3.1). Each cell can host one building. A building exists only if there are floors:

$$y^b \leq \sum^c n_{fl}^{b,c} \quad \forall b \in B$$

$$n_{fl}^{b,c} \geq 0 \quad \forall b \in B, c \in C$$

This is important to allow the construction of PV cells only on rooftops.

technology	const. cost coefficient	linear cost coefficient	lifetime	efficiency	size	Ref.
	$c_{inv,1}$ (CHF)	$c_{inv,2}$ (CHF/kW)	$lt$ (y)	$\eta$ (-)	$f$ (kWth)	
dec. gas boiler	9124 <sup>lin</sup>	177.1 <sup>lin</sup>	20	0.8	[0, 100]	[26,29]
cen. gas boiler S	25387 <sup>lin</sup>	50.74 <sup>lin</sup>	20	0.8	[100, 1000]	[26,29]
cen. gas boiler L	67258 <sup>lin</sup>	14.79 <sup>lin</sup>	20	0.8	[1000, 10000]	[26,29]
cen. CHP	181670 <sup>lin</sup>	242.8 <sup>lin</sup>	25	0.37 (th), 0.45 (el)	[350, 3500]	[26,29]
cen. NSHP S	102449 <sup>lin</sup>	408.7 <sup>lin</sup>	20	0.6	[100, 1000]	[26,30]
cen. NSHP L	258617 <sup>lin</sup>	289.1 <sup>lin</sup>	20	0.6	[1000, 10000]	[26,30]
dec. GSHP	41864 <sup>lin</sup>	2916.6 <sup>lin</sup>	20	0.43	[0, 100]	[26,33]
PV	-	4000	20	0.16	-	[26]
dec. HTS	1185 <sup>lin</sup>	15.93 <sup>lin</sup>	15	-	[0, 1000]	[30]
cen. HTS	14130 <sup>lin</sup>	7.01 <sup>lin</sup>	15	-	[0, 125000]	[30]
network pipes	752.8 CHF/m	7047 CHF/m <sup>2</sup>	60	-	-	[25]

lin: original cost function of author was linearized  
 dec.: decentralized  
 cen.: centralized

S: small  
 L: large

Table 3: Energy technology parameters.

### Energy utilities

For a technologic and economic description of all utility models besides of PV it is referred to the work of [22]. All numeric values of utility parameters can be found in Table 3. The electric power generation of PV cells depends on the solar irradiance, electric efficiency and maximum available collector area:

$$\dot{E}^{u,t} = \dot{I}^t \cdot \eta_{el,PV} \cdot A_{PV,max} \quad \forall u \in U_{PV}, t \in T$$

Considering an available area as defined in [23], only a share of the footprint area can be covered by PV:

$$A_{PV,max} = 0.16 \cdot A_{fp}$$

The factor 0.16 was found to be the average available collector area per building over the building stock of the Canton of Geneva [20].

### Heating network

To account for heat losses in the pipes, the distance-dependent temperature model of [24] is adapted.

In order to estimate the investment costs for the network pipes, the overall pipe length is estimated using the formula of [25]:

$$L_{max} = 2 \cdot (n_b - 1) \cdot T \sqrt{\frac{A_{nb}}{n_b}}$$

The number of buildings  $n_b$  is assumed to be the number of cells. To account for reduced costs in case not all cells are connected to the network, the maximum length  $L_{max}$  is weighted with the number of used heat transfer stations (HTS) at buildings [26]:

$$L = \frac{\sum^{u=HTS} y^u}{n_b} \cdot L_{max}$$

The investment costs for the pipes are then estimated according to [25]:

$$C_{inv} = (c_{inv,1} + c_{inv,2} \cdot d_{ln}) \cdot L$$

### Energy target constraints

The 2000 watts society targets of covering 75% of energy supply with RES is formulated as a constraint to the MILP problem:

$$f_{n-RES,grid} \cdot E_{grid,import} + H_{gas,import} \leq (1 - f_{RES,target}) \cdot \sum_b (E^b + Q^b)$$

Thus the sum of imported non-renewable electricity and gas may not exceed a specified share of the electricity and heat demand of all buildings.

Parameter	Unit	Value	Ref.	Remarks
interest rate	-	0.06	[30]	-
gas price	CHF/kWh	0.0844	[28]	average price for residential building categories
electricity price buy	CHF/kWh	0.2076	[31]	Canton of Geneva, 2015
electricity price sell	CHF/kWh	0.0944	[31]	Canton of Geneva, 2015
external temperature	°C	-7, 12	[25,30]	-
soil temperature	°C	10	[7]	-
annual solar irradiation	kWh/m <sup>2</sup> /y	1330	[35]	Geneva, 2014
peak solar irradiance	kW/m <sup>2</sup>	1.07	[35]	Geneva, 2014
gas emissions	kg <sub>CO2eq</sub> /kWh	0.203	[34]	Switzerland, 2015
electric grid emissions	kg <sub>CO2eq</sub> /kWh	0.122	[32]	electricity mix of Swiss suppliers, 2012
share non-renewables electric grid	-	0.433	[32]	electricity mix of Swiss suppliers, 2012
electric grid losses	-	0.09	[22]	-
max. building height	m	21	LCI	-
max. extra height	m	6	LCI	can be allowed for residential floors
floor height residential	m	4	[20], LCI	average over building stock of Geneva
floor height office	m	4.8	[20], LCI	average over building stock of Geneva
footprint	m <sup>2</sup>	400	[20], LCI	average over building stock of Geneva
cell size	m <sup>2</sup>	900		respects minimum distances as defined by law
minimum density index (ID)	-	1.8	LGZD, PDQ	-
building distances	m	10-20	LCI	street gap between buildings defined relatively to the building heights
design velocity pipes	m/s	2.5	[30]	-
thermal conductivity pipes	W/m/K	0.028	[37]	-
average diameter pipes	m	0.222	[20]	average over heating networks of Geneva
thickness pipe walls	m	0.05	[26]	-
topology factor	-	0.23	[25]	Statistical analysis performed on the heating networks of Geneva
waste heat power	MW	10.75	CET	assumed to be constant over the year
waste heat temperature	°C	20	CET	assumed to be constant over the year
waste heat price	CHF/kWh	0.05	[38]	estimated from current end price of 0.22 CHF/kWh minus investment and operational costs

Table 4: General parameters.

### 3 RESULTS AND DISCUSSION

The present study is based on the indicative information available in the current state of the project.

#### 3.1 Case-study application of the MILP model

The values for the parameters considered used are summarized in Table 4. The optimization was performed with CPLEX 12.6.0.0 [27] with a time limit of 300 seconds.

The strength of the model is demonstrated by addressing the fivefold interdependencies between social targets, environmental constraints, economic implications, technological feasibility and urban layout (Fig. 3). The costs were minimized for varying densities and RES targets.

As can be seen in Fig. 4, there are thresholds above which costs start to increase faster with density. This is due to changes in the technological system chosen. In the first section, fully decentralized systems of ground source heat pumps (GSHP), boilers and PV are favoured (Fig. 5).

As soon as all cells are occupied, buildings closest to the feed-in point of the industrial waste heat are connected to the heating network (Fig. 6). This can be explained with the following observations. For a waste heat price of 0.05 CHF/kWh the optimization model finds the decentralized options to be economically slightly preferable. However,

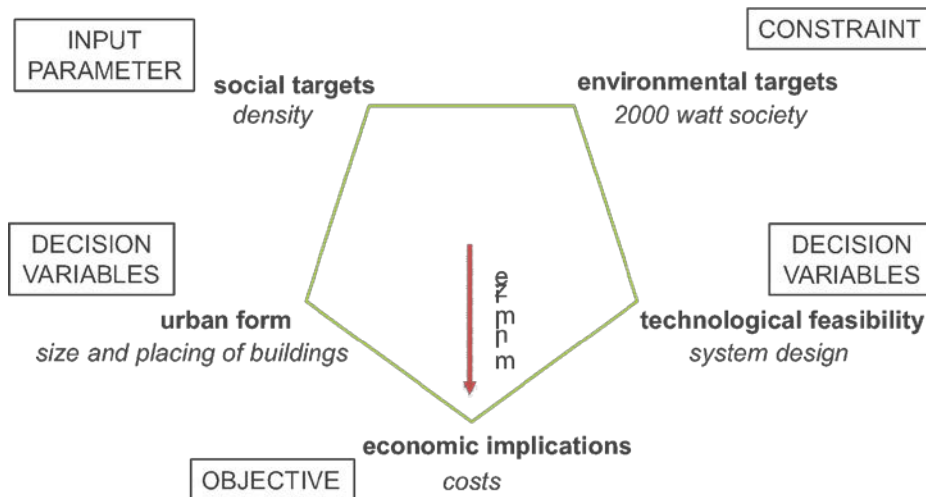

Fig. 4: Depiction of the fivefold interdependencies in the optimization problem.

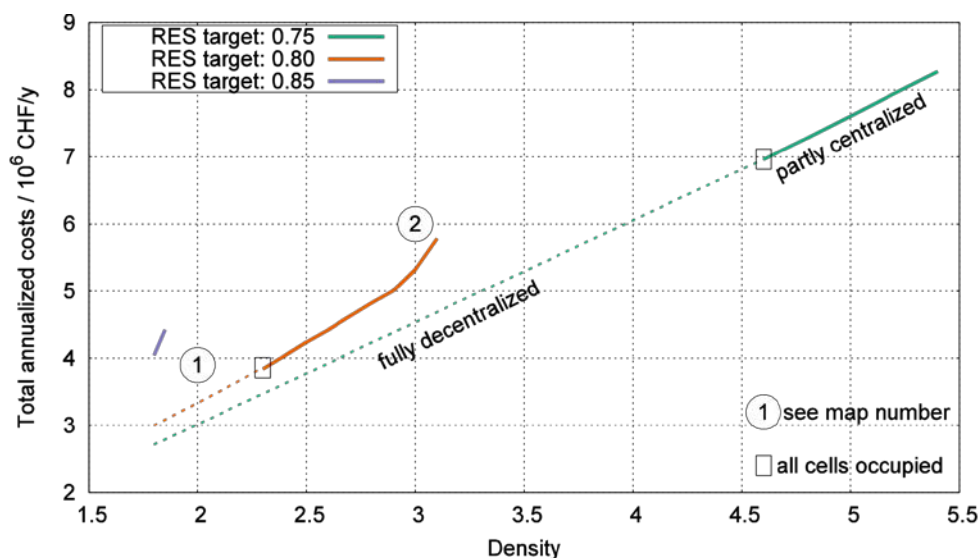
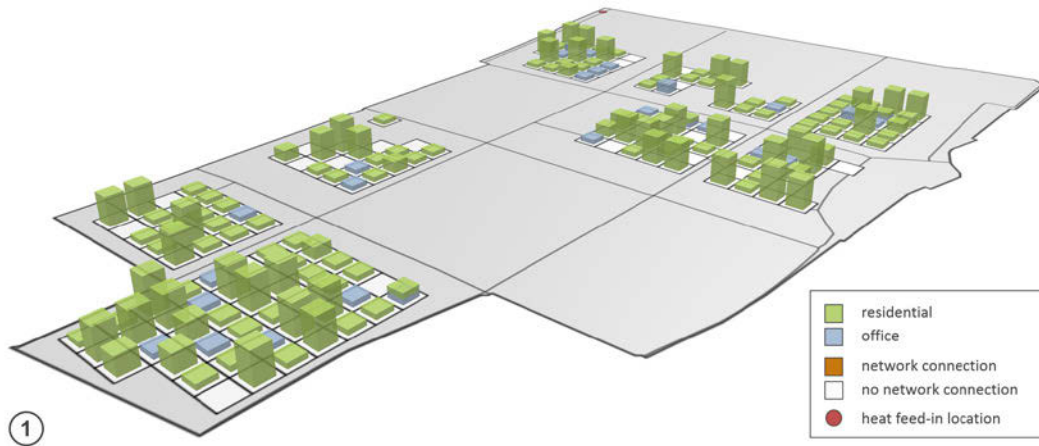

Fig. 3: System costs for different RES targets, over varying density. The boxes indicate when all cells host a building. The line style indicates the shift from a decentralized system (dotted) to the use of a heating network (plain). Maps are provided for the numbered points hereafter.





①

Fig. 5: Map of case-study, for a density of 2. The RES target is achieved with a fully decentralized energy supply system, resulting in an overall scattering of buildings.

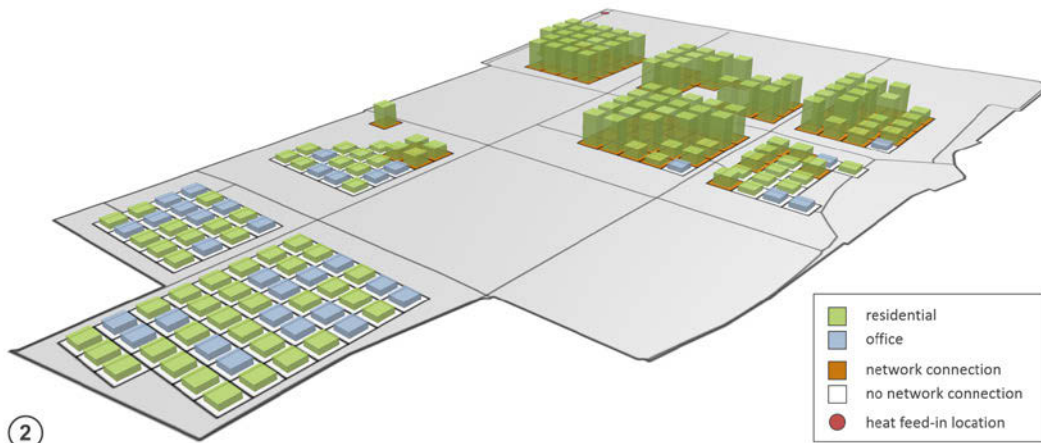

②

Fig. 6: Map of case-study, for a density of 3. The RES target is met by including a heating network. High residential buildings are clustered close to the feed-in point and connected to the network.

already in the decentralized system designs, PV panels are required to meet the RES target. With increasing density, more buildings are built, providing space for additional PV. When all cells are occupied, no more PV can be installed. In order to still fulfil the energetic constraint, the overall system efficiency has to be increased. This can only be achieved by connecting buildings to the network, since a centralized network source heat pump (NSHP) using the industrial waste heat is the most efficient option. The higher the RES target, the lower are these density thresholds.

The main levers in shaping these curves were identified as the achievable share of collector area and the waste heat price. A waste heat price of 0.035 CHF/kWh is found to be the threshold up to which a network is installed even for low densities, regardless of the RES target.

### 3.2 General results

As stated in Section 1.2, one of the goals of the work was to understand and reinforce links between several separated areas.

- Regarding the first link, the proposed methodology represents a useful way for planners to anticipate effects of their decisions, e.g. regarding density on energy strategies. In this sense, the link may be consolidated with a better understanding of two sides of the planning scope: urban and energy aspects.
- The model-based approach supports decisions simultaneously on the building and the district scale. It thus allows to depict interdependencies between them, which, for complexity reasons, may be difficult to grasp with mere intuition.

- The third link can similarly be improved with a MILP approach, which has proven effective to quickly generate information from which calculations can be performed. This represents an improvement from more general approaches which rely on rough approximations and assumptions regarding the unknown information.
- The fourth link was successfully established, and the planning framework and constraints could be modelled through mathematical expressions in line with legal and practical constraints.

#### 4 CONCLUSIONS AND OUTLOOKS

Stemming from the identification of key planning requirements, the adopted methodology could provide deep insights into how planning decisions are interdependent with energy questions.

A first set of questions could be tackled using an MILP model approach. The presented results illustrated how the choice of a density value influences the cost of achieving energy targets, an energetically optimal urban layout and a corresponding energy supply scenario.

Additionally, required links for improved planning of districts were established. Although the adopted methodology allowed to gain a clearer insight into the nature of these links, additional efforts remain to reinforce them. This includes the ongoing development of the model, as well as the embedding of this work in the framing research project which aims to develop a wide range of urban energy systems simulation tools and decision support methods [36].

#### 5 ACKNOWLEDGMENTS

The authors gratefully acknowledge the European Commission for providing financial support during the conduct of research under the FP7-PEOPLE-2013 Marie Curie Initial Training Network "CINERGY" project with Grant Agreement Number 606851. The authors would also like to thank the Canton of Geneva for their fruitful discussions supporting this work.

#### 6 REFERENCES

1. IEA, World Energy Outlook, STEDI MEDIA. IEA Publications, Paris, 2008.
2. ODYSSEE-MURE, Energy Efficiency Trends and Policies in the Household and Tertiary Sectors, ADEME, 2015.
3. ECTP-CEU, The Charter of European Planning, European Council of Spatial Planners (ECTP-CEU), Barcelona, 2013.
4. Teriman, S., Yigitcanlar, T., et al., Sustainable Urban Development: An Integrated Framework for Urban Planning and Development, Rethinking Sustainable Development: Urban Management, Engineering, and Design, p. 1, 2010.
5. Knox, P. L., Cities and Design. London ; New York, NY: Routledge, 2010.
6. Immendoerfer, A., Winkelmann, M., et al., Energy Solutions for Smart cities and Communities - Recommendations for Policy Makers. European Union, 2014.
7. Weber, C. and Shah, N., Optimisation based design of a district energy system for an eco-town in the United Kingdom, vol. 36, no. 2, pp. 1292–1308, 2011.
8. Strasser, H., Implementation of Energy Strategies in Communities--From Pilot Project in Salzburg, Austria, to Urban Strategy, in *ASHRAE Transactions*, Chicago, 2015, vol. 121, pp. 176–184.
9. Zanon, B. and Verones, S., Climate change, urban energy and planning practices: Italian experiences of innovation in land management tools, *Land Use Policy*, vol. 32, pp. 343–355, 2012.
10. Caputo, P. and Pasetti, G., Overcoming the inertia of building energy retrofit at municipal level: The Italian challenge, *Sustainable Cities and Society*, vol. 15, pp. 120–134, 2015.
11. Koch, A., Girard, S., et al., Towards a neighbourhood scale for low- or zero-carbon building projects, *Building Research & Information*, vol. 40, no. 4, pp. 527–537, 2012.
12. Williams, P. M., Community strategies: mainstreaming sustainable development and strategic planning?, *Sustainable Development*, vol. 10, no. 4, pp. 197–205, 2002.
13. Keirstead, J., Samsatli, N., et al., SynCity: an integrated tool kit for urban energy systems modelling, in *Proceedings of the 5th Urban Research Symposium*, Marseille, 2009.
14. Novatlantis, Swissenergy, et al., Smarter Living, Moving Forward to a Sustainable Energy Future, with the 2000 Watt Society, 2011.
15. Gallez, C. and Maksim, H.-N., A quoi sert la planification urbaine ?, *Flux*, no. 69, pp. 49–62, 2007.
16. UN-Habitat, Global report on human settlements 2009: Planning sustainable cities. Earthscan, 2009.
17. Di Nucci, M. R. and Pol, O., Planning and implementation process assessment report -

CONCERTO Report, Vienna: Austrian Institute of Technology, 2010.

18. strategy, *Merriam-Webster.com*. 2016.

19. operational, *Merriam-Webster.com*. 2016.

20. SITG | Le territoire genevois à la carte. [Online]. Available: <http://ge.ch/sitg/>. [Accessed: 15-Jan-2016].

21. MINERGIE, MINERGIE-P, 2016. [Online]. Available: <https://www.minergie.ch/standard-minergie-p-fr.html>. [Accessed: 19-Jan-2016].

22. Weber, C. I., Multi-objective design and optimization of district energy systems including polygeneration energy conversion technologies, EPFL, 2008.

23. Desthieux, G., Carneiro, C., et al., Cadastre solaire du Canton de Genève - Phase 1, hepia, Geneva, 1, 2011.

24. Wakui, T., Kinoshita, T., et al., A mixed-integer linear programming approach for cogeneration-based residential energy supply networks with power and heat interchanges, vol. 68, pp. 29–46, 2014.

25. Girardin, L., A GIS-based Methodology for the Evaluation of Integrated Energy Systems in Urban Area, École Polytechnique Fédérale de Lausanne, 2012.

26. Fonseca, J. A., Nguyen, T.-A., et al., City Energy Analyst (CEA): Integrated framework for analysis and optimization of building energy systems in neighborhoods and city districts, *Energy and Buildings*, vol. 113, pp. 202–226, 2016.

27. CPLEX. IBM, 2014.

28. Eidgenössisches Departement für Wirtschaft, Bildung und Forschung, Eidg. Volkswirtschaftsdepartement EVD - Preisüberwachung. [Online]. Available: <http://gaspreise.preisueberwacher.ch/web/index.asp?z=9>. [Accessed: 08-Jan-2016].

29. Voll, P., Automated optimization-based synthesis of distributed energy supply systems, 1. Aufl. Aachen: Wissenschaftsverl. Mainz, 2014.

30. Henchoz, S., Potential of refrigerant based district heating and cooling networks, PhD thesis, EPFL, Lausanne, 2015.

31. Eidgenössische Elektrizitätskommission, Strompreis-Webseite der EICOM: Vergleichen Sie Ihren Strompreis. [Online]. Available: <https://www.strompreis.elcom.admin.ch/Map/ShowSwissMap.aspx>. [Accessed: 08-Jan-2016].

32. Frischknecht, R., Itten, R., et al., Treibhausgas-Emissionen Schweizer Strommixe, Bundesamt für Umwelt BAFU, Uster, Switzerland, 2012.

33. Bochatay, D., Blanc, I., et al., Projet PACOGEN, Evaluation économique et environnementale de systèmes énergétiques à usage résidentiel, 2005.

34. Röthlisberger, R., Faktenblatt CO<sub>2</sub>-Emissionsfaktoren des Treibhausgasinventars der Schweiz, Bundesamt für Umwelt BAFU, O051-345, 2015.

35. Federal Office of Meteorology and Climatology, MeteoSwiss IDAWEB: Welcome at IDAWEB! [Online]. Available: <https://gate.meteoswiss.ch/idaweb/system/welcome.do>. [Accessed: 08-Jan-2016].

36. CI-ENERGY. [Online]. Available: <http://www.ci-nergy.eu/>. [Accessed: 18-Jan-2016].

37. Kristjansson, H. and Bøhm, B., Optimum Design of Distribution and Service Pipes, in *EH&P*, Hanover, 2006, vol. IV.

38. CADZIPLO SA, Projet CADZIPLO, 2014. [Online]. Available: [http://www.energy8.ch/projets/item/download/4\\_9a368980c0148c627a6bc6e7250acc72](http://www.energy8.ch/projets/item/download/4_9a368980c0148c627a6bc6e7250acc72).





## Expanding Boundaries: Systems Thinking for the Built Environment

### WHICH ADDITIONAL IMPACT CATEGORIES ARE READY FOR UPTAKE IN THE CEN STANDARDS EN 15804 AND EN 15978? EVALUATION FRAMEWORK AND INTERMEDIATE RESULTS

K. Allacker<sup>1\*</sup>, D. De Lathauwer<sup>2</sup>, W. Debacker<sup>3</sup>, W.C. Lam<sup>3</sup>, K. Boonen<sup>3</sup>

<sup>1</sup> KU Leuven, Faculty of Engineering Science, Department of Architecture, Kasteelpark  
Arenberg 1, B-3001 Leuven, Belgium

<sup>2</sup> Federal public service, Health, Food chain safety and Environment, Eurostation,  
Place Victor Horta, 40-10, B-1060 Brussel, Belgium

<sup>3</sup> VITO, Unit Smart Energy and Built Environment, Boeretang 200, B-2400 Mol,  
Belgium

\*Corresponding author; e-mail: karen.allacker@kuleuven.be

#### Abstract

The European standards developed by CEN TC350 for assessing the sustainability of construction works, i.e. EN15804 (construction products) and EN15978 (buildings), consider seven impact categories within the life cycle assessment approach. When looking at commonly used Life Cycle Impact Assessment (LCIA) methods (e.g. IMPACT 2002+ and ReCiPe) and the recently developed Product Environmental Footprint (PEF) of the European Commission, more impact categories are included. Scientific studies indicate the necessity to consider these additional impact categories. The question arises if declaring solely the seven CEN TC350 impact categories is sufficient or if additional impact categories should be taken up. In the context of this potential need for a broader environmental perspective, a new work item proposal within CEN TC350 has been approved for drafting a CEN Technical Report (TR) containing an overview and evaluation of additional impact categories. The goal of the TR is to collect information on six impact categories: human toxicity, ecotoxicity, particulate matter, ionising radiation, land use/biodiversity and water scarcity. The TR can be used as input for further discussions on the need for updating the standards. The draft TR was finalised in January 2016 on the basis of literature study and feedback from experts, amongst others the EC-Joint Research Centre. The process of the development of the TR and the framework for the evaluation of the seven additional impact categories (and potentially others in future) are described. Finally, the main draft conclusions on the impact categories are summarised.

#### Keywords:

Life cycle assessment; impact categories; European Standards; EN 15804; EN 15978

## 1 INTRODUCTION

The European standards developed by CEN TC350 for assessing the sustainability of construction works, i.e. EN15804 (construction products) and EN15978 (buildings), consider seven impact categories within the life cycle assessment (LCA) approach. The seven impact categories included are: depletion of abiotic resource elements, depletion of abiotic resource fossil fuels, acidification for soil and water, ozone depletion, global warming,

eutrophication and photochemical ozone creation. A more extended list of impact categories is however considered in commonly used Life Cycle Impact Assessment (LCIA) methods (e.g. IMPACT 2002+ and ReCiPe) and the recently developed EC Product Environmental Footprint (PEF). Scientific studies indicate that different design decisions might be taken when a more extended number of impact categories are considered in LCA studies of buildings. The question arises if declaring solely the seven CEN

TC350 impact categories is sufficient or if additional impact categories should be included in the standards in order to have a more comprehensive insight in the environmental impact of construction products and buildings. In the context of this potential need for a broader environmental perspective, a new work item proposal (NWIP) within CEN TC350 has been approved in November 2014 for drafting a CEN Technical Report (TR) containing an overview and evaluation of several additional impact categories: Work Item 00350023 0. The goal of the TR is twofold, i.e. (1) to develop a framework to evaluate if additional impact categories should be included in the CEN standards EN 15804 and EN 15978, and (2) to collect information on six impact categories: human toxicity, ecotoxicity, particulate matter, ionising radiation, land use/biodiversity and water scarcity (in line with the evaluation framework developed). The TR serves as input for further discussions on the need for updating the previously mentioned standards. The draft TR was finalised in January 2016 on the basis of a literature study, feedback from experts, amongst others the EC-Joint Research Centre, and feedback from the members of Working Group 1 (cf. construction products) and 3 (cf. buildings) of CEN TC 350 (WG1&3). The process of the drafting of the TR and the framework for the evaluation of the six additional impact categories (and potentially others in future) are described. Finally, the main draft conclusions on the impact categories are briefly summarised.

## 2 METHODS

### 2.1 Process drafting Technical Report

The TR has been developed based on a multidimensional approach. In a first step and preliminary to the acceptance of the NWIP, a two-day workshop was organized (June 2014) in Brussels to gain insights from LCA experts and experts from the construction sector on the additional impact categories to be analysed. The workshop was attended by about 60 participants representing LCA practitioners, knowledge institutes, standardisation entities, sector federations and the European Commission (DG Environment, DG Growth and DG JRC), whereof 17 experts (i.e. Karen Allacker, Jerome Payet, Morten Birkved, Wim Debacker, Lorenzo Benini, Sebastien Humbert, Assumpció Antón, Mark Goedkoop, Johannes Kreissig, Stephan Pfister, Peter Maydl, Jeroen Guinée, Frank Van Assche, Frank Werner, David Crowhurst, Ralf Lehman, Sylviane Nibel). The participants contributed to the workshop by sharing their perspective on the relevance of the additional impact categories and the scientific robustness of the impact assessment models available to assess the impacts. The information from the workshop was accompanied by an in depth literature review by KU Leuven,

VITO and the Belgian Federal Public Service Health, Food Chain Safety and Environment, and a consultation of the EC-JRC experts. This led to a first draft TR. In order to include stakeholder consultation in the drafting, several WG1&3 meetings have been organised during which the intermediate versions were discussed and improved and based on which the draft TR has evolved to the final draft of January 2016. At several moments written feedback was asked and received by the members of WG1&3.

The final draft version of the TR (January 2016) includes a description of the evaluation framework developed and the evaluation of each of the six additional impact categories. Possibilities for uptake in the standards are included for each impact category in an informative annex. In the subsequent section 2.2 the evaluation framework is described and in section 2.3 the main conclusions from the evaluation are summarised for each impact category evaluated.

### 2.2 Evaluation framework

The evaluation framework (Fig. 1) is subdivided in two sets of criteria: standardization criteria and scientific/applicability criteria 0 but were slightly changed in order to avoid duplications with the standardisation criteria. The scientific/applicability criteria are further referred to as ILCD criteria. The framework consists of seven steps.

The **first step** evaluates the environmental relevance of the impact category by answering the following questions:

- What is the degree of pertinence of the indicator(s) for the addressed impact category?
- Is it documented clearly what the proposed additional impact category addresses?
- Is the impact category identified as important by the society?
- Is the building sector contributing to the impact category?
- Is it documented whether it is a midpoint or an endpoint indicator or whether it is a resource indicator?

In the **second step** the relevance of the impact category for buildings and construction products is evaluated based on the following questions:

- Could the impact category and related indicator affect the design of a building or building product?
- Is the impact and related indicator specific to the site (i.e. applicable only to the site of the works)?
- Is the impact and related indicator specific to the construction products used in the building, i.e. is it an embodied impact?
- Could the impact category and indicator affect the choice of materials and products incorporated in buildings?

In the **third step** the policy relevance is evaluated. In respect of legislation, regulation and/or official recommendations, the following question is asked:

- Is the impact category/indicator referred to in any existing/notified national or European legislation?

#### Standardisation criteria

**Step 1:** Identify the environmental relevance of the effects and impact categories to be addressed at the building level.

**Step 2:** Assess the likely relevance of the environmental impact; both at building and at product level (site specific vs embodied) relevance for buildings and construction products.

**Step 3:** Assess the policy relevance: are the indicators already referenced in European legislation or in other European standards?

The first three steps evaluate the relevance in relation to the TC350 standards of the impact category and its possible indicators.

#### ILCD criteria

#### ILCD criteria

**Step 4:** Establish a list of possible performance based and quantifiable indicators (LCA-based).

**Step 5:** Assess existing LCIA models based on the science based criteria developed in the ILCD Handbook.

**Step 6:** Evaluate existing LCIA models based on practice based criteria: availability of characterization factors and data, and applicability at EU level.

**Step 7:** Determine if there is any authoritative body in place and their recommendation if any.

If the LCIA models have been identified as having significant drawbacks (i.e. not applicable, or a low level of scientific robustness), non-LCA methods may be searched for and described.

Fig. 1: Evaluation framework for the additional environmental impact categories.

The character of the indicator is evaluated in the **fourth step**. As the CEN standard provides quantified environmental information, a prerequisite for the indicators is that they are quantifiable. Preference is given to LCA indicators rather than to quantifiable non-LCA indicators (e.g. embodied energy and amount of occupied land).

The **fifth step** focuses on the scientific robustness and certainty of the LCIA models and is based on the ILCD handbook criteria. This evaluation step considers the scientific quality of the characterisation models, the completeness of the scope, the quality of the modelling of the cause-effect chain and the transparency and level of reproducibility.

The **sixth step** evaluates the applicability of the LCIA model by considering the following criteria:

- Availability of life cycle inventory (LCI) data and characterisation factors

- Experience: how widely is the model used?
- Availability of the model within existing, widely used LCA tools (within the TR, Simapro (Pre Consultants), GABI (Thinkstep) and openlca (GreenDelta) are considered)

As broad acceptance is important in standardisation, in the **final step** it is determined whether there is an authoritative body behind a model (consensus/international endorsement), and if such an authoritative body has made any recommendations regarding any LCIA model and related indicator.

In summary, for each identified impact category/group of environmental effects identified in step 1 and found relevant in step 2 and/or step 3, a list of possible LCA-based assessment models and related indicators is established (step 4). In step 5 the models and indicators are assessed regarding the science based criteria of the ILCD handbook (see further) and in step 6 the practicality is evaluated. In the final step 7, recommendations of any authoritative body are identified.

## 3 RESULTS

### 3.1 Human toxicity

Human toxicity is found to be relevant for the environment and both at building and construction product level. Human toxicity is moreover part of European and international policies. The USEtox model v1.01 is identified as the preferred LCIA model for human toxicity, as it is a consensus model that is updated regularly 0.

The members of the CEN TC 350 WG1&3 identified some issues regarding the scientific robustness and practicality of the USEtox model v1.01. More specific concern exists on the availability and quality of LCI data (both foreground and background). These concerns are mainly identified for the product group metals.

The TR hence concludes that toxicity assessment of construction products and buildings using current methodologies should not be communicated without interpretation due to inherent uncertainties and recommends further improvements on the availability and quality of LCI data. It is however important to note that recently USEtox v.2.0 0 has been released but could not be evaluated in the timeframe of the TR. It is suspected that several of the identified issues regarding scientific robustness and practicality have been resolved in this latest version.

### 3.2 Ecotoxicity

For freshwater ecotoxicity, identical conclusions are drawn as for human toxicity (see section 3.1). Marine and terrestrial ecotoxicity are found relevant for the environment and both construction

products and buildings, but the USEtox model v1.01 is found to be insufficiently robust.

### 3.3 Particulate matter

Particulate matter (PM) is found to be relevant for the environment, and both at the building and product level, and is part of European and international policies.

RiskPoll/Humbert (2009) is identified as the recommended LCIA model 00. It is highlighted that it is difficult to accurately measure total suspended particles (TSP) and different PM fractions, especially for fugitive dust sources or in humid conditions. If to be included in the CEN standards, guidelines for measurement (e.g. Dutch standard, NTA 8029+C1:2012 0) might be an important issue.

### 3.4 Ionising radiation

The analysis of ionising radiation revealed that it is relevant for the environment. Both at the construction product level and at the building level it is however not clear if ionising radiation is relevant. It is identified as a potentially good indicator to identify nuclear energy use during the life cycle of the building and construction products. It is clarified that ionizing radiation exposure of a person is mainly caused by exposure to natural sources; direct exposure from the ground is sometimes high and is influenced by location and the design of the building. Ionising radiation is part of European, international and national policies and is widely regulated in EU member states.

For human health, the LCIA model of Frischknecht et al. 0 and for ecosystem health, the LCIA model of Garnier-Laplace et al. 0 substantially meet the evaluation criteria in the framework.

### 3.5 Impacts related to land use / biodiversity

The land use interventions evaluated in the TR cover both land transformation and land occupation. The impact of these interventions on biodiversity, soil quality and ecosystem functions is evaluated. The impact on land as resource is not evaluated as no explicit statistical or other data is found.

It is concluded that land use related to buildings (in situ and embodied land use) and construction products (embodied land use) cause relevant environmental impacts. If land use is to be included, it would be important to include it in a comprehensive way in order to understand the burdens that arise. No single indicator is currently available which cover the several impacts identified. The EC-JRC is developing such single land use indicators (expected September 2016).

From the currently available LCIA models, the following are identified as the most preferred. For the impact on biodiversity, the LCIA model for land use within ReCiPe (based on Köllner, 2001 0) is identified as the best available method to assess biodiversity losses. It however neglects land transformation to and from mineral extraction sites

and urban areas. Eco-Indicator 99 0, on the other hand, includes land transformation impacts and takes into account land transformation processes related to mineral extraction and the urban built area. This method however is based on old data with a geographically limited scope and needs to be updated. For the impact on soil quality, the LCIA model of Mila I Canals et al. 0 (Soil Organic Matter) seems to substantially meet the evaluation criteria in the framework. Although this method has been updated (new data and a better global coverage) by Brandao and Milà i Canals, 2013 0, the updated method is currently not available in the common LCA software and hence fails the practicality criterion. Regarding ecosystem functions, the only available LCIA model is the LANCA model which does not meet the evaluation criteria in the framework.

### 3.6 Water scarcity

Water scarcity is found to be relevant for the environment, and both at building and at product level. Water scarcity is part of European, international and national policies.

It is concluded that impact category water scarcity better represents the environmental impact associated with water use than the current measure of net freshwater use included in the EN 15804 and EN 15978.

Regarding the choice of indicator, for both human health and quality of ecosystems, the WULCA recommended method – AWaRe – substantially meets the evaluation criteria of the framework 0. However, it has not been widely applied yet.

## 4 CONCLUSIONS

A draft version of the CEN technical report on additional environmental impact categories has been finalised in January 2016. The main outcomes of this TR are presented in this paper. The TR reveals that many of the additional impact categories analysed are relevant for the environment, for construction products and buildings and have a policy relevance. For many of the additional impact categories sufficiently robust LCIA models are available, however sometimes with some issues to be taken care of. The TR will be an important document for discussing the uptake of additional impact categories in the current standards EN 15804 and EN 15978.

## 5 ACKNOWLEDGMENTS

We thank the member of the CEN TC WG1 and WG3, the EC-JRC and all experts involved for their valuable inputs.

## 6 REFERENCES

1. EN 15804:2012+A1:2013, Sustainability of construction works – Environmental products



declarations – Core rules for the product category of construction products (2013).

2. EN 15978:2011, Sustainability of construction works – Assessment of environmental performance of buildings – Calculation method (2011).

3. Humbert, S., De Schryver, A., Bengoa, X., Margni, M., Jolliet, O. Impact 2002+: user guide draft version Q2.21. (2012), Quantis, Switzerland.

4. Goedkoop, M., Heijungs, R., Huijbregts, M., De Schryver, A., Struijs, J., van Zelm, R. ReCiPe 2008: a life cycle impact assessment method which comprise harmonised category indicators at the midpoint and the endpoint level. First edition report I: characterization. (2012) Ruimte en Milieu Ministerie van Volkshuisvesting, Ruimtelijke Ordening en Milieubeheer, The Netherlands.

5. European Commission. 'ANNEX II Product Environmental Footprint (PEF) Guide', in: 2013/179/EU: Commission Recommendation of 9 April 2013 on the use of common methods to measure and communicate the life cycle environmental performance of products and organisations. Official Journal of the European Union, L 124, Volume 56, 4 May 2013.

6. Allacker, K. Sustainable Building: The development of an evaluation method, PhD dissertation (2010). KU Leuven, [https://lirias.kuleuven.be/bitstream/123456789/267749/1/Karen%20Allacker\\_PhD\\_final\\_for%20upload.pdf](https://lirias.kuleuven.be/bitstream/123456789/267749/1/Karen%20Allacker_PhD_final_for%20upload.pdf)

7. Allacker, K., Souza, D.M., Sala, S. Land use impact assessment in the construction sector: An analysis of LCIA models and case study application. The international Journal of Life Cycle Assessment, 2014. 19(11): p. 1799-1809.

8. Allacker, K., Debacker, W., Delem, L., De Nocker, L., De Troyer, F., Janssen, A., Peeters, K., Servaes, R., Spirinckx, C., Van Dessel, J., Environmental Profile of Building Elements, (2013) Danny Wille, Mechelen.

9. Allacker, K., Sié, M., Trigaux, D., Payet, J., De Troyer, F., Search for the environmental indicators relevant for the building sector, in: Proceedings of the World Sustainable Building Conference. 2014: Barcelona, Spain.

10. [http://portailgroupe.afnor.fr/public\\_espace/normalisation/CENTC350/index.html](http://portailgroupe.afnor.fr/public_espace/normalisation/CENTC350/index.html); [www.din.de/en/getting-involved/standards-committees/nabau/projects/wdc-proj:din21:204129314](http://www.din.de/en/getting-involved/standards-committees/nabau/projects/wdc-proj:din21:204129314)

11. European Commission-Joint Research Centre (EC-JRC). Institute for Environment and Sustainability: International Reference Life Cycle Data System Handbook (ILCD) (2011). ILCD Handbook: Recommendations for Life Cycle Impact Assessment in the European context. First edition, November 2011. EUR 24571 EN.

Luxemburg. Publications Office of the European Union.

12. Rosenbaum, R.K. et al.: USEtox - The UNEP-SETAC toxicity model: recommended characterization factors for human toxicity and freshwater ecotoxicity in Life Cycle Impact Assessment. The International Journal of Life Cycle Assessment, 2008. 13(7): p. 532-46.

13. Fantke, P., et al. USEtox 2.0: Recommended characterization factors for human and freshwater ecotoxicity for new and updated substances, exposure pathways, and regions, 2015, SETAC 25th Annual Meeting. Barcelona, Spain.

14. Rabl, A., and J.V. Spadaro, The RiskPoll Software, version is 1.051 and Greco et al., Spatial patterns of mobile source particulate matter emission-to-exposure relationships across the United States. Atmospheric Environment, 2007. 41: p. 1011-25.

15. Humbert, S. Geographically Differentiated Life-cycle Impact Assessment of Human Health. Doctoral dissertation (2009). University of California, Berkeley, USA.

16. NTA 8029+C1, Determination and registration of industrial particulate matter emissions (2013)

17. Frischknecht, R. et al., Modelling human health effects of radioactive releases in Life Cycle Impact Assessment. Environmental Impact Assessment Review, 2000. 20(2): p. 159-89.

18. Garnier-Laplace, J.C. et al. A Screening Level Ecological Risk Assessment and ranking method for liquid radioactive and chemical mixtures released by nuclear facilities under normal operating conditions, in: Proceedings of the International conference on radioecology and environmental protection. 2008. Bergen. and Garnier-Laplace, J.C. et al. A Screening Level Ecological Risk Assessment and ranking method for liquid radioactive and chemical mixtures released by nuclear facilities under normal operating conditions. Radioprotection, 2009. 44(5): p. 903-08.

19. Köllner, T. Land use in Product Life Cycles and its Consequences for Ecosystem Quality. PhD thesis no. 2519. 2001, University St. Gallen. And: Countryside Survey 2000: Survey of Broad Habitats and Landscape features.

20. Goedkoop, M. and R. Spriensma, The Eco-indicator 99: A damage oriented method for Life Cycle Impact Assessment Methodology, 2002. Ministry of VROM, The Hague, The Netherlands

21. Mila I Canals, L., Romanya, J. and S.J. Cowell, Method for assessing impacts on life support functions (LSF) related to the use of 'fertile land' in Life Cycle Assessment (LCA). Journal of Cleaner Production, 2007. 15: p. 1426-40.

22. Brandao, M. and L. Milà i Canals, Global characterization factors to assess land use impacts on biotic production. *The International Journal of Life Cycle Assessment*, 2013. 18: p. 1243-52.

23. AWaRe (WULCA) [www.wulca-waterlca.org/project.html](http://www.wulca-waterlca.org/project.html)



## Expanding Boundaries: Systems Thinking for the Built Environment

### INTEGRATED PROCESSES FOR THE EVALUATION AND OPTIMIZATION OF BUILDING PERFORMANCES

B. Daniotti<sup>1</sup>, A. Pavan<sup>1</sup>, D. Pasini<sup>1\*</sup>, M.A. Chiozzi<sup>2</sup>

<sup>1</sup> Politecnico di Milano, Department of Architecture, Built Environment and Construction Engineering, Via G. Ponzio, 31 - 20133 Milano - Italy

<sup>2</sup> Queensland University of Technology, School of Civil Engineering and Built Environment, 2 George St - Brisbane, QLD 4000 - Australia

\*Corresponding author; e-mail: daniela.pasini@polimi.it

#### Abstract

An efficient way to reduce the consumption of materials and energy in buildings is represented by an improvement of building processes. A regulated information management is essential to avoid delays, cost overrun, errors and lack of performances during the whole building life-cycle.

Thus, the adoption of an integrated design process is becoming of great importance; BIM, considered as building information modelling and management, could be a way to perform such integrated processes.

A central repository for project data and information could be advantageous if knowledge is exchanged between different stakeholders (e.g. through IFC or gbXML). Moreover, BIM supports building performance analyses and evaluations, allowing, for instance, simulation of energy performance, computation of environmental impacts and estimation of costs. In this way, it is possible to compare several options and choose the optimal ones.

The importance of the link between BIM and sustainable buildings is underlined by the state of the art, such as the Green Overlay to the RIBA Outline Plan of Work, the series 10 of COBIM related to energy analysis, and the BIM Guide for energy performance developed by GSA.

An Italian case study for the improvement of the building process is Innovance, a research project with the aim of developing a national database for the construction sector. In order to improve the collection, storing, management and sharing of data, an unambiguous classification system and standardized technical sheets have been developed and a web portal has been designed to ensure the interaction among stakeholders.

#### Keywords:

BIM; Information Management; Behavioural Modelling; Interoperability.

### 1 INTRODUCTION

As the construction sector has a great influence on energy consumption and greenhouse gas emissions, AECO (Architecture, Engineering, Construction and Operation) industry is putting effort into the reduction of these impacts during the whole building life-cycle.

Several improvements have been made as related to technological aspects, but changes have been introduced even in the building process.

Indeed, several benefits can be achieved through an integrated building process.

Particularly, this paper focuses on the support of BIM (Building Information Modelling) to the evaluation and optimization of building performance and sustainability.

The research goals are twofold: 1) highlighting how an integrated process could improve the achievement of an energy efficient and sustainable behaviour of buildings; 2) considering how digitalization could support sustainability

evaluation through information management at building level.

The analysis aims to show how benefits can be achieved not only in the design stages, when designers can predict buildings' impacts, but also during the operational stages, when users' behaviour and activities affect buildings' emissions and consumptions.

In fact, sustainability should be actively considered in design, construction and operation of buildings, as clarified in the Green Overlay to the RIBA (Royal Institute of British Architects) Outline Plan of Work [0]. Each stage (from the strategic definition to the in-use stage) is characterized by sustainability checkpoints, in order to illustrate behaviours and activities that should support a more sustainable approach.

Also in the Italian context, sustainable aspects are recently considered, as it is emerged in a proposal for integrating the new Building Code [0]. The fulfilment of sustainable criteria is required, giving additional points to solutions with low environmental impact and low cost, evaluated during the whole life-cycle.

## 2 STATE OF THE ART

Many stakeholders are involved and a great amount of information is required during a building process [0], especially regarding well-performing and energy efficient buildings. However, the lack of communication, coordination and transparency among stakeholders often affects the fulfilment of requirements and performances. The fragmented nature of the construction industry hinders integration, both among the actors and the stages of a building process. For this reason, the effective exchange of information may be very difficult [0].

New methods and technologies have been developed to manage a great variety of information, improving its traceability and possibility of use. The whole building process is becoming more integrated and organic, with a close collaboration of several stakeholders, especially in the case of intelligent buildings.

Within this context, BIM is emerging as it allows the integration and cooperation, for example by making it possible to share information and documents between all the actors, through a central data repository. It is possible to use, exchange and update information along the building life-cycle, collecting data in a database and using them repeatedly. In this way, data are not re-inserted and so they are not redundant [0].

### 2.1 Evaluation of sustainability in design stages

Different methods and tools can be used to estimate and compare building performance since the design phases [0, 0].

In this context, topics of BIM and sustainability are interrelated. Several guidelines and standards have been developed by different corporations, as the series 10 of Finnish COBIM (Common BIM Requirement) related to energy analysis [0] or the BIM Guide for energy performance developed by US GSA (General Services Administration) [0].

Generally, the assessment of building sustainability is performed during the design stages, mostly for the certification rather than for the evaluation and comparison of different alternatives. This is mostly due to the lack of data and to the great amount of time required to perform an analysis. In order to bring forward this analysis, it should be useful to define and keep track of the necessary information and the appropriate modelling procedures for each specific analysis that should be carried out.

This should be possible by connecting, as an example, BIM and LCA (Life Cycle Assessment). Indeed, the research and implementation of BIM has become widespread as it can be considered as a process to support communication (sharing data), collaboration (acting on shared data), simulation (using data for prediction) and optimization (using feedback to improve design, documentation and delivery) [0]. Therefore, BIM should support the design and analysis of building systems since the early design stage, when specific sustainability trade-off analyses could be conducted, different design options could be compared, decision-making processes could be performed, "what-if" scenarios could be developed, and most effective decisions could be made [0, 0, 0, 0]. Since the conceptual design phase, all the stakeholders should be able to acquire, store and organize data related to different performance of components, and so to generate feedback during the design process [0]. Once these data are stored, they could be made routinely available and could be updated during the whole life-cycle.

These data could be used in BEM (Building Energy Models) to compare different design choices and predict future buildings' behaviour. However, as values and schedules are only assumed for most of the input parameters, results are not accurate enough to predict the real consumption during operation [0].

BIM and BEM could be used together to perform buildings' performance analyses along the whole life-cycle. Several researches have been carried out in relation to the theme of interoperable information modelling for energy performance analyses, focusing on open formats as IFC and gbXML [0, 0, 0]. However, interoperability still represents criticalities in relation to the complete integration and unambiguous interpretation of results between BIM and BEM [0, 0].

## 2.2 Evaluation of sustainability in operational stages

The achievement of optimized performances in buildings is challenged by the uncertainty that affects the surrounding environment, consequently buildings' impacts should be considered also in operational stage.

As related to buildings' use phase, the gathering of required information for the assessment of buildings' performances could be improved through real-time metering and monitoring technologies. The collected information could be useful for the definition of control strategies by which it would be possible to harmonize sustainability goals with comfort goals.

BACS (Building Automation and Control Systems) could measure real impacts and consumptions, monitoring and controlling different building systems. In this way, appropriate feedbacks could be provided to users, increasing their awareness and promoting sustainable behaviours. At the same time, these feedbacks could be used to train buildings in order to adapt their behaviours to particular conditions.

Recently, pervasive sensor networks allow an accurate and dynamic monitoring of the indoor environment, taking advantage of the knowledge of the overall building and executing actions for forcing the building towards expected states [0]. Indeed, control policies could be implemented in advance, through integrated models for the prediction of the near future behaviour of the controlled environment under specific conditions.

In this context, BIM could be coupled with real time monitoring systems gleaned from BACS for recording and storing parametric real-time data [0]. Some attempts have been done in using remote sensors to populate BIM models. Data acquisition technology has already been integrated with BIM tools (i.e. Onuma Planning Systems), linking models with real time energy sensors, lighting and webcam data [0].

## 3 CASE STUDY

Innovance is an Italian research project funded by the Ministry of Economic Development. The aim is the creation of an interoperable platform for exchanging information in the building industry, through a central database to smartly store and share information.

### 3.1 Goal

The scope of the research project is threefold: 1) developing an unambiguous classification system for every object of the construction sector; 2) collecting informative attributes through datasheets; and 3) designing a user friendly website.

The Italian construction sector is characterized by a great amount of rules, definitions and practices, causing difficulties in data transmission among stakeholders. For this reason, the aim of the project has been the creation of a coding system based on a standardized and unequivocal name. In order to manage and use information through the construction process, technical datasheets have been defined among homogeneous objects categories. Users can easily and quickly retrieve and compare information throughout a web-based portal that relies on a database.

A great part of the information stored in the database could be used for a sustainable design of buildings. In fact, several specific sections of the database are related to the assessment of environmental impacts (in conformity with UNI EN 15804:2014 [0]) or to the simulation of energy performance (according to the Italian normative context).

### 3.2 Methodology

The classification and definition of every object involved in the construction process have been the core of the research. The database is structured considering objects belonging to:

- Functional-Spatial System, for describing a whole building and its division into functional and spatial homogeneous areas
- Technological System, for collecting information on construction products, in site elements and technical elements
- Processual System, related to activities, machineries and manpower

As related to the development of an unambiguous classification system, the research has been carried out starting from the literature review, analysing existing coding standards, i.e. UNI 11337 [0], UNI 8290 [0], and OMNICLASS [0]. Each object is defined by an unequivocal name, made by the aggregation of seven characteristics. These seven fields are: category, typology, reference standard or function, principal performance, geometry, dimensions, physical-chemical characteristics (Fig. 1).

ELEMENTO PER MURATURA		DIMENSIONE	
Tipologia	A foratura verticale rettificato	Altezza [mm]	235
Riferimento normativo	UNI EN 771-1	Foratura [N]	45
Conducibilità termica [W/mK]	0,148	Lunghezza [mm]	250
Geometria	Con zigrinature per l'intonaco	Spessore [mm]	300
		Materiale	Laterizio alleggerito

Fig. 1: Unequivocal name.

Moreover, every object is described by a set of standardized informative attributes, identified through a direct partnership with association and federation of product manufacturers and

construction. As related to the technological system, the main sections are: code, description, use, manufacturer's data, performances, sustainability impacts, geometry, visual aspects, physical-chemical properties, tolerances, composition, transportation, packaging, product declarations and attachments. A standardized template for each category of construction objects allows storing data always in the same position, enhancing comparisons and statistics between them and simplifying decision making processes (Fig. 2).

The image shows a technical datasheet for a construction object. It is divided into several sections:

- Informazioni identificative del prodotto:** Includes fields for 'Descrizione Commerciale' (e.g., 'Resistenza RFD, RFD, RFD'), 'Codice interno attribuito da INNOVANCE' (e.g., 'DR 417'), 'Codice QR', and 'Decorazione da Capotesto tecnico'.
- Caratteristiche Fisico-chimiche Qualitative:** A section for qualitative physical-chemical characteristics.
- Caratteristiche Fisico-chimiche Quantitative:** A section for quantitative physical-chemical characteristics.
- Tolleranze:** A section for tolerances.
- Composizione:** A section for composition.
- Caratteristiche Essenziali:** A section for essential characteristics, including 'Conduttività termica' (0.18), 'Resistenza a compressione caratteristica (paragonata alle faccende)', and 'Resistenza a compressione caratteristica (paragonata alle faccende)'. Each has a 'valore' and 'unità' column.
- Normativa di riferimento (EN/ETI):** Lists standards like 'EN 12618'.
- Dimensioni e sezioni:** Includes 'Dimensione di sezione per installazione' and 'Classificazione secondo norme di tecnica e materiali'.

Fig. 2: Technical datasheet.

### 3.3 Results

The result of the project has been an open web-portal for the use and exchange of data between several stakeholders.

The web portal should allow users to manage their projects, by these functions (Fig. 3):

- objects creation, allowing the definition of an unambiguous name and adding information to technical datasheets according to the standardized structure of the database
- object search, in order to download and manage information related to all the stored objects, also with pre-formatted views targeted to different users' categories (clients, designers, contractors, manufacturers, etc.)
- BIM server, to manage a project, from the early phases to construction, use, maintenance and disposal or handover. This section contains standardized folders in which users can upload documents and drawings. It can be used also as a repository, to store BIM models; database interoperability is guaranteed by the adoption of the IFC protocol
- BIM library, allowing users to exchange standardized BIM objects and use them in their own models.

Some actors who can benefit from the portal are:

- manufacturers interested in uploading information about their products;
- construction companies interested in consuming stored information about

products and machineries in their projects, loading data related to in site elements and assembled systems, and adding information related to their activities

- architects and engineers interested in using objects (in particular BIM objects) in their projects
- customers interested in collecting information related to involved stakeholders and following the development of the project.

Through the availability and transparency of all the collected data, stakeholders are able to choose the most sustainable alternatives that fulfil the required performances.

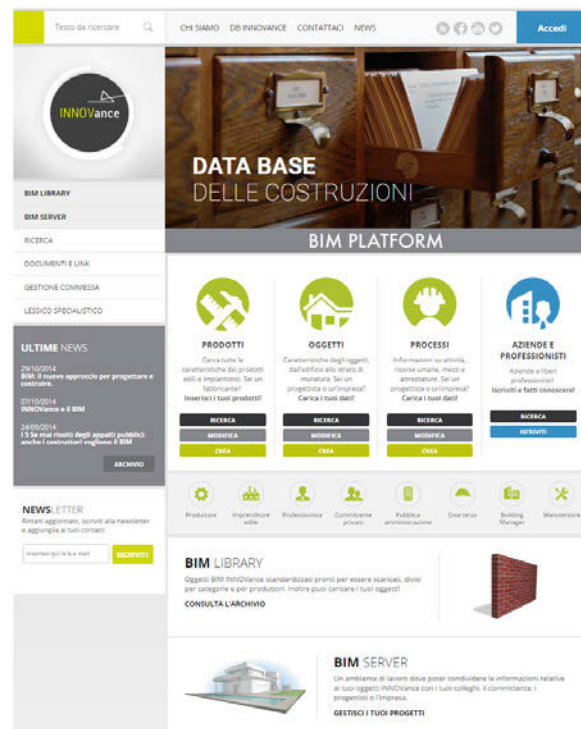

Fig. 3: Web-portal.

### 4 FUTURE WORKS

As related to sustainable buildings, Innovance can be a useful tool, especially in design stages. However, as emerged from the state of the art, it is important to consider sustainability also in operation.

In this way, it should be possible to correlate predicted performance in the design stage with real measurement in the operational one. This would allow defining how occupants can affect buildings' sustainability and how buildings can modify their behaviour according to different conditions. Starting from these considerations, future works should consider building behaviour in operational stage, defining a framework for the evaluation of buildings' sustainability using a whole life-cycle approach, in order to:

- understand whether and how the centrality of users can change the building process
- propose a proper structure for data management and a correct flow of information among different systems for the acquisition and use of knowledge
- extract useful information from available and multifaceted data and develop web interfaces to inform involved stakeholders using real time information.

Therefore, it should be possible to:

- compare how buildings in use differ from the expectations of their design, considering not only the way buildings are designed, but also the way they are used and managed
- define control strategies for the reduction of building impacts;
- provide feedback to users, making them aware of their behaviours.

## 5 CONCLUSION

BIM is an important process to support the evaluation and optimization of buildings' performance, especially considering aspects, such as:

- Integrated design and management of well-performing buildings need BIM as a process for allowing collaboration and cooperation among different actors and skills.
- Simulation of building performance since the design phase requires the integration of tools for parametric modelling and performance analysis.
- Monitoring of building behaviour in the use phase represents the connection between tools for parametric modelling and systems or devices for building automation and control.

In Italy, however, BIM is increasingly becoming widespread, although the implementation process is still at the origin – often only limited to case studies – and proceeds slowly, with a heavy lagging behind other countries.

In this context, Innovance is proposed as a tool to support the implementation of BIM in the Italian construction sector, as it enhances an ordered information management, with particular regard to the design of well-performing buildings.

## 6 ACKNOWLEDGMENTS

The authors would like to mention and acknowledge the whole team involved in the Innovance project, especially F. Re Cecconi, S. Lupica Spagnolo, S. Maltese and V. Caffi.

## 7 REFERENCES

1. Royal Institute of British Architect, RIBA Plan of work 2013, United Kingdom.
2. Delega al Governo per l'attuazione delle direttive 2014/23/UE, 2014/24/UE e 2014/25/UE del Parlamento europeo e del Consiglio.
3. O'Donnell, J.T., Maile, T., Rose, C., Mrazović, N., Morrissey, E., Regnier, C., Parrish, K., and Bazjanac, V., Transforming BIM to BEM: Generation of building geometry for the NASA ames sustainability base BIM, Report of Lawrence Berkeley National Laboratory, 2013.
4. Isikdag, U., and Zlatanova, S., A SWOT analysis on the implementation of Building Information Models within the Geospatial Environment. Urban and Regional Data Management - UDMS Annual 2009, pp.15-30.
5. Laine, T., and Karola, A., Benefits of Building Information Models in energy analysis. Proceedings of Clima 2007 WellBeing Indoors, Helsinki.
6. Schlueter, A., and Thesseling, F., Building information model based energy/exergy performance assessment in early design stages. Automation in Construction, 2009. 18, pp.153-163.
7. Aksamija, A., BIM-based building performance analysis: evaluation and simulation of design decisions. Proceedings of the 2012 ACEEE Summer Study on Energy Efficiency in Buildings.
8. buildingSMART Finland, Common BIM Requirement 2012 - Series 10: Energy Analysis, Finland, 2012.
9. U.S. General Services Administration Public Buildings Service, GSA BIM Guide Series 05: BIM Guide for Energy Performance, USA, 2014.
10. Laiserin, J., Building information modeling for today and tomorrow, To BIMfinity and Beyond!), Cadalyst, 2007. Retrieved from <http://www.cadalyst.com/aec/to-bimfinity-and-beyond-aec-insight-column-3686>.
11. Bank, L.C., McCarthy, M., Thompson, B.P., and Menassa, C.C., Integrating BIM with system dynamics as a decision-making framework for sustainable design and operation. Proceedings of the 1st International Conference on Sustainable Urbanization, 2010.
12. Azhar, S., Building Information Modeling (BIM): Trends, Benefits, Risks, and Challenges for the AEC industry. Leadership and Management in Engineering, 2011. 11, pp.241-252.
13. Cho, C., Chen, D., and Woo, S., Building Information Modeling (BIM) - based design of energy efficient buildings. International Association for Automation and Robotics in Construction, 2011, pp.1079-1084.

14. Jrade, A., and Jalaei, F., Integrating building information modeling with sustainability to design building projects at the conceptual stage. *Building Simulation*, 2013. 6, pp.429-444.
15. Ries, R., and Mahdavi, A., Integrated computational life-cycle assessment of buildings. *Journal of Computing in Civil Engineering*, 2001. 15, pp.59-66.
16. Coakley, D., Raftery, P., Molloy, P., and White, G., Calibration of a detailed BES model to measured data using an evidence-based analytical optimisation approach. *Proceedings of 12th Conference of International Building Performance Simulation Association*, 2011, Sydney.
17. ISO 16739, Industry Foundation Classes (IFC) for data sharing in the construction and facility management industries - First Edition, 2013.
18. Bazjanac, V., IFC BIM-Based methodology for semi-automated building energy performance simulation. *Proceedings of the 25th International Conference on Information Technology in Construction*, 2008.
19. Dong, B., Lam, K.P., Huang, Y.C., and Dobbs, G.M., A comparative study of the IFC and gbXML informational infrastructures for data exchange in computational design support environments. *Proceedings of Building Simulation 2007*.
20. Ciribini, A.L.C., De Angelis, E., Tagliabue, L.C., Paneroni, M., Mastrolembro Ventura, S., and Caratozzolo, G., Workflow of interoperability toward energy management of the building. *Proceedings of ISTeA Conference on environmental sustainability, circular economy and building production*, 2015, pp.443-461.
21. Zanchetta, C., Paparella, R., Cecchini, C., and Alessio, G., Performance based building design through Building Energy Modeling (BEM). *Proceedings of ISTeA Conference on environmental sustainability, circular economy and building production*, 2015, pp.462-481.
22. Ansuini, R., Lemma, M., and Giretti, A., Monitoring system for energy management of buildings: design of models and sensor networks for supporting control systems. *Journal for Housing Science*, 2014. 38 (2), pp.105-114.
23. Mohammed, Z., *Building Information Modeling (BIM) and Building Automation Systems (BAS): potential and innovation in the building industry utilizing integrated BIM and BAS*, 2011.
24. Ozturk, Z., Arayici, Y., and Coates, S. P., Post occupancy evaluation (POE) in residential buildings utilizing BIM and sensing devices: Salford energy house example. 2012. Retrieved from <http://usir.salford.ac.uk/20697/>.
25. UNI EN 15804, Sustainability of construction works - Environmental product declarations - Core rules for the product category of construction products, 2014.
26. UNI 11337, Building and engineering works - Coding criteria of works, activities and resources - Identification, description and interoperability, 2009.
27. UNI 8290-1, Edilizia residenziale - Sistema tecnologico - Parte 1: Classificazione e terminologia, 1981.
28. OMNICLASS, A strategy to classify the built environment, 2013. Retrieved from <http://www.omniclass.org>.





## Expanding Boundaries: Systems Thinking for the Built Environment

### CRITICAL ANALYSIS OF SUSTAINABILITY SCORING TOOLS FOR NEIGHBOURHOODS, BASED ON A LIFE CYCLE APPROACH

D. Trigaux<sup>1\*</sup>, K. Allacker<sup>1</sup>, F. De Troyer<sup>1</sup>

<sup>1</sup> KU Leuven - Faculty of Engineering Science – Department of Architecture – Division of Architectural Engineering, Kasteelpark Arenberg 1 box 2431, 3001 Leuven, Belgium

\*Corresponding author; e-mail: damien.trigaux@asro.kuleuven.be

#### Abstract

The neighbourhood scale has become an important focus in sustainable decision taking. To support designers and building stakeholders several Building Sustainability Assessment Methods (BSAM) have been developed. Among these methods, a distinction can be made between scoring tools and Life Cycle Assessment (LCA) tools. Scoring tools, such as BREEAM Communities and LEED Neighborhood, associate scores to a number of criteria (credits), covering a wide range of sustainability issues such as energy, materials, water, user transport and comfort. LCA tools, such as novaEQUER and GreenCalc+, are based on a systematic study of the environmental impact caused during the entire neighbourhood life span.

This paper analyses the effectiveness of scoring tools in assessing the sustainability of neighbourhoods, by comparing their methodology with an integrated life cycle approach, combining Life Cycle Assessment (LCA) and Life Cycle Costing (LCC). Based on a schematic neighbourhood model, the financial and environmental impact of a number of sustainability measures related to energy use, material use and user transport are evaluated. The results are compared with the credits awarded in BREEAM Communities, regarding those aspects. Based on this comparison, convergences and divergences are highlighted and recommendations for methodological improvements are formulated.

#### Keywords:

BREEAM Communities; Integrated life cycle approach, Life Cycle Assessment; Life Cycle Costing; Sustainability measures

## 1 INTRODUCTION

As buildings interact with their surroundings, the neighbourhood scale has become an important focus in sustainable decision taking. To support designers and building stakeholders, several Building Sustainability Assessment Methods (BSAM) have been developed. Among these methods, a distinction can be made between scoring tools and Life Cycle Assessment (LCA) tools [1]. Scoring tools, such as BREEAM Communities [2] and LEED Neighborhood [3], associate scores to a number of criteria (credits), covering a wide range of sustainability issues such as energy, materials, water, user transport and comfort. LCA tools, such as novaEQUER [4] and GreenCalc+ [5], evaluate the environmental impact generated during the entire neighbourhood life span. A comparative analysis of BSAM tools for neighbourhoods, based on a literature review can be found in [1]. In this study the strengths and weaknesses of the different tools are identified.

Scoring tools are found to be more user-friendly compared to LCA tools, which deal with a huge quantity of data. Moreover scoring systems are more comprehensive as the focus of LCA tools is limited to the environmental dimension of sustainability, neglecting economic, social and quality aspects. However the robustness of scoring tools to support sustainable decision taking is questioned as these tools are not based on a systematic study of impacts.

The goal of this paper is to analyse the effectiveness of scoring tools in assessing the sustainability of neighbourhoods, by comparing their methodology with an integrated life cycle approach, combining Life Cycle Assessment (LCA) and Life Cycle Costing (LCC). In a previous research [6], LEED credits, applied to an office building case study, were analysed based on an LCA. The study revealed discrepancies between the rating levels and their actual environmental impact. In this paper, not only the environmental

impact, but also the financial consequences of a number of sustainability measures related to the energy use, material use and user transport are evaluated, based on a schematic neighbourhood model. The results are then compared with the credits awarded in BREEAM Communities, regarding those aspects.

In the subsequent section, the methodology is presented, including a description of BREEAM Communities, the integrated life cycle approach and the analysed case study. Section 3 focuses on the LCA and LCC results and related BREEAM credits. In section 4, convergences and divergences between the life cycle approach and BREEAM are highlighted. Recommendations for methodological improvements and conclusions are formulated in the final section.

## 2 MATERIALS AND METHODS

### 2.1 BREEAM Communities

BREEAM Communities [2] is a sustainability assessment tool developed in the UK by the BRE Group. The tool focuses on the assessment of moderate to large scale developments. Assessment issues and the related indicators are subdivided in 6 thematic categories: Governance, Social and economic wellbeing, Resources and energy, Land use and ecology, Transport and movement and Innovation. Those issues cover the environmental, economic and social dimension of sustainability but also a number of qualities, such as functional, technical, site and process qualities [1]. The scores for the different indicators are weighted to an overall score by applying weighting factors, defined in consultation with a stakeholder and expert panel. Based on the overall score, a rating is attributed on a scale from Pass, Good, Very Good, Excellent to Outstanding.

### 2.2 Integrated life cycle approach

The integrated life cycle approach used in this paper is based on the sustainability evaluation method for buildings developed in the SuFiQuaD ("Sustainability, Financial and Quality Evaluation of Dwelling Types") research project [7][8]. This method assesses the environmental and financial impact over the entire building life cycle, by combining LCA and LCC calculations. In a recent research, the SuFiQuaD method was extended to the neighbourhood scale level, by evaluating building clusters, in combination with the required road infrastructure [9].

#### *Life Cycle Assessment (LCA)*

The environmental impact assessment method in SuFiQuaD was recently updated within the MMG ("Environmental profile of building elements") research project [10]. In addition to individual impact indicators, the MMG method provides an aggregated single-score indicator, expressed in monetary value (EURO). This indicator represents the external environmental cost caused by

environmental impacts. The environmental data, used in the analysis, are based on the Ecoinvent database version 2.2 [11]. However, in order to increase the representativeness for the Belgian context, Swiss data records were adapted by replacing the Swiss electricity mix and transport processes by European corresponding processes [10].

#### *Life Cycle Costing (LCC)*

The financial impact is calculated based on the LCC methodology. To assess the life cycle financial cost, discounting of future costs is applied, by calculating their present value. More detailed information on the assumptions and economic parameters can be found in [7][8]. The financial data are collected from different sources. Cost of building components are mainly based on the Belgian cost database ASPEN [12][13], combined with product specific data. For data related to road infrastructure and external works, the British Spon's Price Books are used [14][15]. Concerning the energy use, prices per energy source are based on Belgian statistical data [16]. For the financial cost of user transport, a study of Transport & Mobility Leuven is used, including the calculation of consumer prices for different transport modes [17].

### 2.3 Case study

#### *Reference Case*

As reference case, a schematic neighbourhood layout is defined, consisting of detached houses along a roadway with a footpath on both sides (Fig. 1). This neighbourhood layout can be seen as representative for the low density Belgian suburbs. Different assumptions are made. Firstly, simplified box buildings, consisting of 2 floors of each 60m<sup>2</sup>, are used for the analysis. The glazing surface area is assumed to be equal to 15% of the total floor area of each housing unit, in order to achieve a good level of daylighting. Secondly, buildings are composed of standard building elements from the MMG database, which are in line with the low energy standards. Only the space delimiting elements (i.e. floors, walls, roofs, stairs, windows and doors) are considered in the analysis. The technical systems (e.g. heating, ventilation and water supply) are not included. For the road infrastructure, standard road and footpath sections with an asphalt pavement are selected.

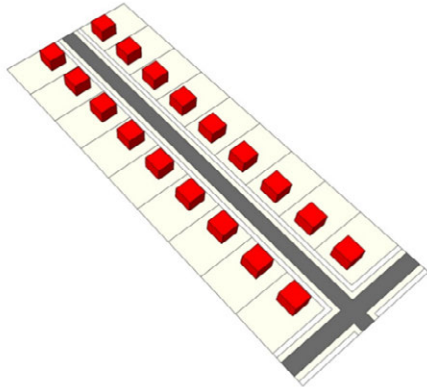

Fig. 1: Schematic neighbourhood layout.

Thirdly, the heating energy use in buildings is calculated based on the dynamic Equivalent Degree Day method, which is a simplified approach to estimate the heating demand in neighbourhoods [18][19]. Regarding user transport, it is assumed that the inhabitants have a transport profile similar to the Flemish average [20].

#### Sustainability measures

In this paper, four measures to improve the sustainability of the neighbourhood are analysed in detail (Fig. 2).



Fig. 2 : Analysed sustainability measures.

The first measure (M1) consists of improving the building insulation level to the passive house standards, by increasing the insulation thickness and replacing double pane glazing by triple pane glazing. Measure 2 (M2) focuses on the use of reclaimed materials for the road base and subbase by replacing crushed gravel by crushed rubble. In the third variant (M3), a bicycle path is integrated along both sides of the road in order to stimulate the use of the bicycle in the neighbourhood. In this scenario, it is assumed that the number of short distance trips by car, i.e. trips over a distance from 0 to 5 km, is reduced by 80%, in favour of the bike. The last measure (M4) focuses on the neighbourhood layout, by

simulating a denser neighbourhood model, consisting of terraced houses.

## 3 RESULTS

### 3.1 Life Cycle Assessment

The results of the LCA, expressed in euro per inhabitant, are shown in Fig. 3, with a distinction between the impact resulting from the building materials, energy use and user transport. For the reference case user transport and building materials contribute most to the life cycle environmental cost, with respectively 71 and 20% of the total impact. The contribution of heating energy use is much lower (9% of the total impact) because the reference case is in line with the low energy standards.

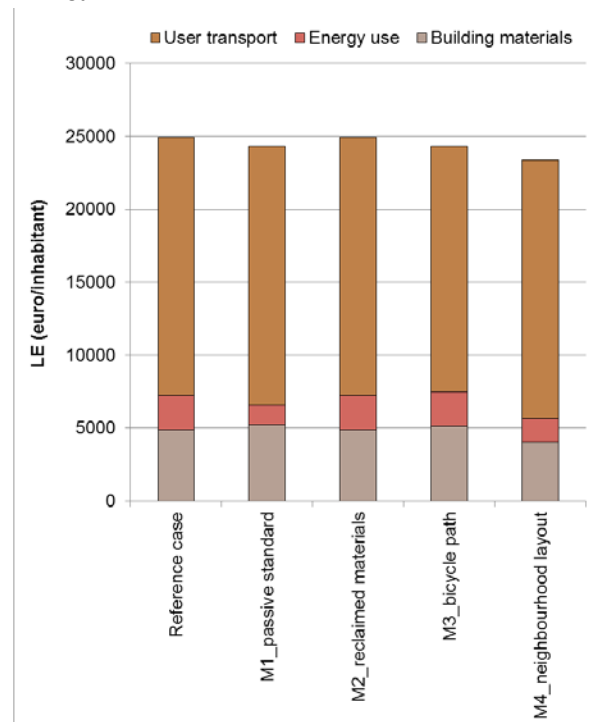

Fig. 3: Life cycle environmental cost (LE) of the reference case and the four sustainability measures.

Considering the different sustainability measures separately, the highest reduction in life cycle environmental cost is obtained for measure M4, followed by M3, M1 and M2, with reductions of respectively 6%, 2%, 2% and 0.02%. Firstly, measure M1 has only a limited influence as the reduction of the environmental cost of energy use is partially compensated by an increase in the cost for building materials. Secondly, the use of reclaimed materials for road construction leads to a negligible reduction in impact because the environmental impact of gravel mainly results from the crushing process, which is also required in the production of rubble. Thirdly, measure M3 results in a small reduction of the environmental cost due to the additional impact of the construction and maintenance of the bicycle path and the limited

reduction of the environmental load based on increased bicycle use. Even if for 80% of the short distance trips bicycles are used, the effect upon the total impact of user transport is limited as short distances represent only a limited fraction of the transport movements. Finally, the highest impact reduction is obtained for measure M4 as compact terraced buildings have a lower material and energy use per inhabitant.

### 3.2 Life Cycle Costing

Similar trends can be seen from the financial results (Fig. 4). User transport and building materials are the biggest contributors, with respectively 50% and 45% of the life cycle cost of the reference case. The contribution of heating energy use is much lower, i.e. limited to 5% of the life cycle cost.

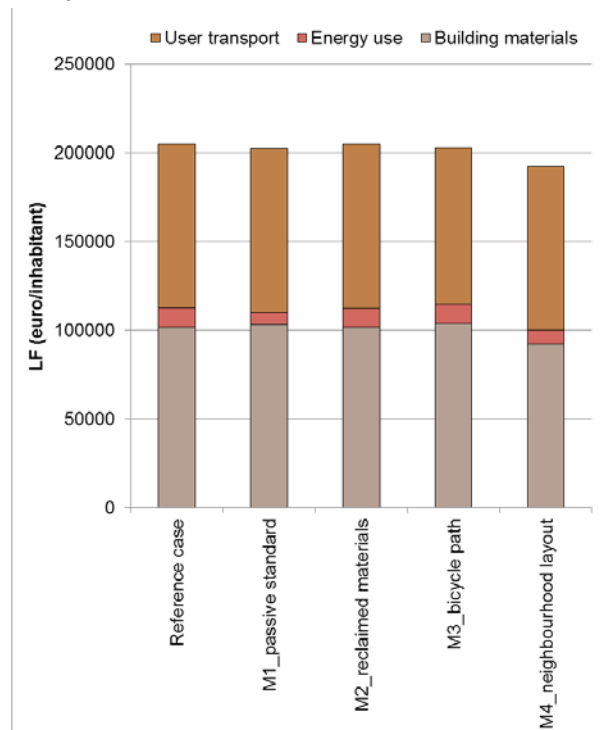

Fig. 4: Life cycle financial cost (LF) of the reference case and the four sustainability measures.

When looking at the sustainability measures, measures M1, M2 and M3 have a negligible impact on the life cycle cost, with reductions of respectively 1%, 0.1% and 1% compared to the reference case. Similar to the environmental cost, the highest reduction (6%) in life cycle cost is obtained for the denser neighbourhood layout.

### 3.3 BREEAM credits

In BREEAM Communities different assessment issues in the categories “Resources and energy” (RE) and “Transport and movement” (TM), are linked to the impact of building materials, energy use and user transport. An overview of those assessment issues and the related weighting factors is given in Fig. 5. Most credits are awarded for issues related to user transport (16.5%),

followed by the building materials (8.1%) and energy use (4.1%).

For each sustainability measure, we estimated the number of credits awarded in BREEAM. Firstly, measure M1 results in a reduction of 13% in CO<sub>2</sub> emissions compared to the Target CO<sub>2</sub> Emission Rate, defined in the English building regulations [21]. For this measure, a weighted score of 0.4% is attributed to the assessment issue “RE 01 – Energy strategy”. Secondly, a weighted score of 1.3% is awarded to “RE 05 – Low Impact materials” for the use of reclaimed road construction materials. Thirdly, the integration of a bicycle path results in a weighted score of 2.1% for the assessment issue “TM 03 – Cycling network”. Finally, no specific credit is awarded for measure M4 as the neighbourhood layout is not evaluated in any assessment issue.

ASSESSMENT ISSUES	WEIGHTING (%)
<b>Building materials</b>	<b>8.1</b>
RE 02 – Existing buildings and infrastructure	2.7
RE 05 – Low impact materials	2.7
RE 06 – Resource efficiency	2.7
<b>Energy use</b>	<b>4.1</b>
RE 01 – Energy strategy	4.1
<b>User transport</b>	<b>16.5</b>
TM 01 – Transport assessment	3.2
TM 02 – Safe and appealing streets	3.2
TM 03 – Cycling network	2.1
TM 05 – Cycling facilities	1.1
TM 04 – Access to public transport	2.1
TM 06 – Public transport facilities	2.1
RE 07 – Transport carbon emissions	2.7

Fig. 5: BREEAM Communities assessment issues related to building materials, energy use and user transport.

## 4 DISCUSSION

Based on the comparison of the LCA/LCC results with the BREEAM credits, convergences and divergences can be identified. Concerning the convergences, BREEAM allocates a high number of credits to assessment issues related to user transport, which is also one of the main contributors to the neighbourhood life cycle environmental and financial cost. Furthermore, a limited number of credits are attributed to issues linked to energy use, which contributes to a small part of the impact in low energy neighbourhoods.

However discrepancies are found between the BREEAM credits and the LCA/LCC results (Fig. 6). Firstly, a weighted score of 1.3% is awarded to measure M2, while the use of reclaimed road construction materials has a negligible influence on the financial and environmental impact. Secondly, the neighbourhood layout seems to be a key parameter to reduce the financial and environmental impact of neighbourhoods but no credit is attributed to this aspect in BREEAM. Finally, the consequences of burden shifting between sustainability aspects are not taken into

account in the BREEAM methodology. For example, credits are awarded for improvements in energy efficiency, without considering the potential impact increase related to the building materials.

	M1	M2	M3	M4
LCA (impact reduction)	2%	0.02%	2%	6%
LCC (impact reduction)	1%	0.1%	1%	6%
BREEAM (credits)	0.4%	1.3%	2%	0%

Fig. 6 : Comparison between the LCA/LCC results and the BREEAM credits for the four sustainability measures.

## 5 CONCLUSIONS

In this paper, the scoring tool BREEAM Communities is compared with an integrated life cycle approach, combining LCA and LCC. The analysis of a number of sustainability measures shows discrepancies between the LCA/LCC results and the credits awarded in BREEAM. Measures leading to higher reductions in financial and environmental impact are not always stimulated, confirming the assumption that scoring tools are not adapted to support sustainable decision taking [1].

Therefore two recommendations are formulated. Firstly, the weighting factors in scoring tools should be adjusted based on a detailed life cycle study of the assessment issues. Moreover, assessment criteria which result in a low reduction of the financial and environmental impact should be removed. Secondly, a more in depth adaptation would be to integrate life cycle evaluation criteria in scoring tools in order to increase their robustness. For example, second generation scoring tools, such as DGNB New Urban Districts [22], already include a number of criteria based on LCA and LCC for the evaluation of the economic and environmental dimension of sustainability.

In this research, only the preliminary results of a more extended research on sustainability scoring tools were presented. Further research should focus on the analysis of additional sustainability measures and the application to other case studies in order to confirm the above mentioned conclusions.

## 6 REFERENCES

- Trigaux D, Allacker K, De Troyer F. Comparative analysis of Building Sustainability Assessment Methods for neighbourhoods. In: Allacker K, Z. Khan A, editors. *Architecture and Sustainability: Critical Perspectives for Integrated Design*, Brussels: Luca - KU Leuven Press; 2014.
- BRE. *BREEAM Communities, Technical manual*. 2012.
- USGBC. *LEED 2009 for Neighborhood Development*. 2012.
- IZUBA énergies. novaEQUER. <http://www.izuba.fr/logiciel/novaequer> [accessed January 14, 2016].
- GreenCalc+ 2013. [www.greencalc.com](http://www.greencalc.com) [accessed January 25, 2016].
- Humbert S, Abeck H, Bali N, Horvath A. Leadership in Energy and Environmental Design (LEED) - A critical evaluation by LCA and recommendations for improvement. *Journal of Life Cycle Assessment* 2006. DOI: 10.1065/lca2006.12.291.
- Allacker K, De Troyer F, Trigaux D, Geerken T, Debacker W, Spirinckx C, et al. *SuFiQuaD: Sustainability, Financial and Quality Evaluation of Dwelling types*. Brussels: Belgian Science Policy (BELSPO); 2013.
- Allacker K. Sustainable building, The development of an evaluation method. *PhD dissertation*. KU Leuven, Heverlee, 2010.
- Trigaux D, Allacker K, De Troyer F. Model for the environmental impact assessment of neighbourhoods. In: Passerini G, Brebia CA, editors. *Environmental Impact II, Second International Conference on Environmental and Economic Impacts on Sustainable Development, incorporating Environmental Economics, Toxicology and Brownfields*. Ancona, Italy: WIT Press; 2014. DOI: 10.2495/EID140091.
- Allacker K, Debacker W, Delem L, De Nocker L, De Troyer F, Janssen A, et al. *Environmental profile of building elements*. Mechelen: OVAM; 2013.
- Ecoinvent centre. Ecoinvent 2014. <http://www.ecoinvent.ch/> [accessed January 25, 2016].
- ASPEN, editor. *ASPENINDEX - Nieuwbouw (translated title: ASPENINDEX - New construction)*. 39th ed. Antwerpen: 2008.
- ASPEN, editor. *ASPENINDEX - Onderhoud, ombouw (translated title: ASPENINDEX - Maintenance, renovation)*. 39th ed. Antwerpen: 2008.
- Spon press, editor. *Spon's External Works and Landschape Price Book*. 34th edition. London: AECOM; 2015.
- Spon press, editor. *Spon's Civil Engineering and Highway Works Price Book*. 29th edition. London: AECOM; 2015.
- CREG. <http://www.creg.be/nl/compprix.html> [accessed January 17, 2016].
- Delhaye E, De Ceuster G, Maerivoet S. *Internalisering van externe kosten van transport in Vlaanderen (translated title: Internalisation of*

*external cost of transport in Flanders*). Mechelen: VMM; 2010.

18. Trigaux D, Allacker K, De Troyer F. A simplified Approach to integrate Energy Calculations in the Life Cycle Assessment of Neighbourhoods. *Sustainable habitat for developing societies, 30th International PLEA Conference*. Ahmedabad, India: CEPT University Press; 2014.

19. Trigaux D, Oosterbosch B, Allacker K, De Troyer F. A design tool to optimize solar gains and energy use in neighbourhoods. In: Cucinella M, Pentella G, Fagnani A, D'Ambrosio L, editors. *Architectuur in (R)Evolution, 31st International PLEA Conference*. Bologna, Italy: Ass. Building Green Futures; 2015.

20. Declercq K, Janssens D, Wets G. *Onderzoek Verplaatsingsgedrag Vlaanderen 4.5 (2012-2013), Tabellenrapport (translated title: Research Displacement Behaviour in Flanders 4.5 (2012-2013), Table report)*. Diepenbeek: Instituut voor Mobiliteit, Universiteit Hasselt; 2014.

21. HM Government. The Building Regulations 2010 - Conservation of fuel and power - Approved Document L1A 2014.

22. DGNB 2015. [www.dgnb.de](http://www.dgnb.de) [accessed January 25, 2016].



## Expanding Boundaries: Systems Thinking for the Built Environment

### BUILDING OCCUPANCY CERTIFICATION: DEVELOPMENT ON AN APPROACH TO ASSESS BUILDING OCCUPANCY

O. Guerra-Santin<sup>1\*</sup>, T. Jaskiewicz<sup>1</sup>, J. Doolaard<sup>1</sup>, D. Keyson

<sup>1</sup> Faculty of Industrial Design Engineering, Delft University of Technology

\*Corresponding author; e-mail: o.guerrasantin@tudelft.nl

#### Abstract

Improving energy efficiency in commercial buildings is of great importance, given the large percentage of energy consumed in the sector. However, the incentives to save energy in these environments are unusual. From the perspective of managers, energy consumption is only a very small part of the financial burden of companies in comparison to materials, rent or salaries, and thus, economic incentives have a low impact in these environments. On the one hand, unlike in home environments, occupants of office building do not see a direct financial effect on their energy related occupancy practices, as so, their incentive is also not a monetary one. Thus, to effectively reduce energy consumption in office buildings, a different approach should be followed. The Building Occupancy Certification System (BOCS) project aims at developing a building evaluation system focused on the building's occupancy instead of its technical or physical characteristics. The objective of BOCS is the reduction of energy consumption in office buildings while improving indoor conditions. In this regard, the improvement of indoor conditions and thus, productivity, is the incentive for company managers and staff to implement the BOCS system. Though, keeping environmental awareness visible in the agenda. This paper presents the preliminary results from the first BOCS pilot study in the Netherlands, regarding the building performance in terms of thermal comfort and indoor environmental quality. This study focuses on the data collection and analysis.

#### Keywords:

Building occupancy; office buildings; monitoring; thermal comfort

### 1 INTRODUCTION

Improving energy efficiency in commercial buildings is of great importance, given the large percentage of energy consumed in the sector. However, the incentives to save energy in these environments are unusual [1]. Often, companies do not own the building they occupy and therefore any investment on low carbon technologies is out of their hands. In addition, energy consumption is only a very small part of the financial burden of companies, in comparison to materials, rent or salaries, and thus, economic incentives have a low impact in these environments (Joosstens 2014, oral communication). On the one hand, unlike in home environments, occupants of office building do not see a direct financial effect on their energy related occupancy practices, as so, their

incentive is also not a monetary one. In addition, occupancy behaviour is greatly affected by the type of building and its installations. Very environmentally friendly occupancy patterns in an energy inefficient building will not show up in the energy bill, and so, the efforts of the occupants would not be visible or rewarded. On the other hand, a very wasteful occupancy in a very energy efficient building might hinder the buildings' performance, but might not be discovered looking only at energy figures. Thus, to effectively reduce energy consumption in office buildings, a different approach should be followed.

The Building Occupancy Certification System (BOCS) project aims at developing a building evaluation system focused on the building's occupancy instead of its technical or physical characteristics. The objective of BOCS is the

reduction of energy consumption in office buildings while improving indoor conditions. In this regard, the improvement of indoor conditions and thus, productivity, is the incentive for company managers and staff to implement the BOCS system. Though, keeping environmental awareness visible in the agenda.

The purpose of the BOCS system is twofold. Firstly, it will provide a more accurate building performance assessment, which will be useful to building owners and financial institutions to take decisions regarding the implementation of renovation schemes and low carbon technologies. Secondly, it will provide building managers and users with the necessary information to decrease the energy consumption and carbon emissions during the occupancy phase of the building.

The impact of BOCS is related to three main objectives: to increase the occupants' comfort and satisfaction with their environment; to decrease energy consumption in the building; and to change occupants behaviour toward more sustainable practices. All of the above are of course, deeply connected. To achieve these objectives, the BOCS system comprises three different activities: 1) monitoring indoor environment, contextual parameters and occupants' behaviour, 2) engaging occupants into providing self-report data regarding their comfort and activities [2,3], and 3) providing feedback to occupants (e.g. managers, staff, facilities managers) regarding occupancy practices and their (positive or negative) effect on energy consumption and indoor environment. This paper reports on the first BOCS pilot in the Netherlands, which focused on indoor environment and self-reported comfort.

## 2 DATA AND METHODS

The BOCS approach aims at researching office occupant social practices, as well as designing, developing and testing solutions for improving these practices, all of which are supported by a dedicated BOCS platform. The BOCS aims to employ state of the art monitoring and information systems to gather information about indoor parameters, occupant behaviour (occupancy practices); and indoor comfort [4]. All the measured data has a direct or indirect effect on energy consumption and indoor environmental quality. Therefore, the system is based on the quantitative assessment of occupancy practices and factors related to energy consumption and indoor environment.

Monitoring building performance is necessary to develop and establish the building occupancy evaluation system. The data collected during monitoring activities in the buildings will be included in the BOCS database, which will be the basis for the building certification system. The

data will provide the information needed to define the efficiency of diverse building operating practices and behaviours.

In the first phase of the project, we identified indoor comfort as the most challenging data collection for the project. Therefore, the first BOCS pilot focused on self-reporting indoor comfort data. Energy consumption and building operation are thus, out of the scope of this paper. There are two methods to collect data for the evaluation of thermal comfort: measurements of indoor parameters, and application of thermal comfort surveys [5,6]. The first method involves physical monitoring of the building (thus, objective data) while the surveys gather subjective data from the occupants and expresses also preferences for thermal comfort and differences between individuals.

Data collection tools have been developed for the Building Occupancy Certification System (BOCS) The BOCS platform has been developed to facilitate development behavioural change solutions. The platform consists of monitoring of sensor and self-reporting nodes, optional feedback devices, online interfaces, and a back-end for collecting and processing gathered data. The resulting approach provides a way for organising research, innovation and implementation of solutions in a living lab context, which allows parallel execution of research and innovation, providing new opportunities for addressing the challenges of social practice change [4]. The approach is organised around the BOCS platform, which is a software and hardware platform supporting performing of objective and subjective measurements in context, providing feedback to users, while also allowing easy modifications and addition of features by employing a modular system architecture.

The BOCS platform has been designed to support the system's flexibility and ability of fast adaptations regarding types of collected data, types of sensors used, types of self-reporting interfaces, and to support rapid development of context-specific screen-based, as well as physical feedback interfaces. Using the platform, two data collection devices were developed: the BOCS Sensor Box and the Self-reporting device.

The Sensor Box has been developed using modular electronic components. The version of the Sensor Box used during the pilot reported in this paper consists on sensors measuring CO2 concentration, humidity, sound level, temperature, light intensity and movement were used. The integration of indoor parameters and contextual data within one single box was decided to test the complexities associated to the placement of the sensor boxes within the offices, and the number of boxes required per monitored



building. The pilot version of the sensor box can be seen in Figure 1.



Fig. 1: Sensor box. Fig. 2: Self-reporting device.

The self-reporting device was developed after the co-creation sessions with participants from the monitored office building [4]. The device aims at providing a vehicle for the participants to provide reliable input on their personal comfort. As result of the co-creation sessions, it was decided that participants should be asked their feedback on thermal comfort, air quality and noise level, since these were the factors that the co-creators (participants in the co-creation session) considered as important issues in their workspaces. However, the participants stressed their preference to only provide input when they were feeling discomfort. Although the researchers acknowledged the risk for the self-reporting device to become a 'complaining tool', it was decided to test this solution in the first pilot. The self-reporting device for this first pilot can be seen in Figure 1.

### 3 RESULTS FIRST DUTCH PILOT

This section shows the preliminary results of the summer pilot monitoring campaign in a large building complex in South Holland, The Netherlands. The main activity of the institute located in the monitored building is research and development of technology.

The purpose of the pilot was manifold. Firstly, the pilot aimed at testing the co-creation workshops in the working environment. These sessions are documented in a companion paper. Secondly, the pilot aimed at testing the Sensor Boxes and Self-reporting devices created after the co-creation workshop both in terms of reliability and usefulness of the information collected. Thirdly, the monitoring pilot campaign aimed at providing insights into the data analysis and communication of results of the building performance.

The Building Occupancy Certification System aims at providing insights into the building occupancy performance in three aspects: energy savings, indoor environmental quality, and occupancy practices. Within the indoor environmental quality, we find two different aspects of investigation: the objective

measurements and evaluation of the indoor quality, and the subjective experiences from the occupants of the building.

For the first pilot study, the energy savings potential of the monitored buildings was not measured, since the very small sample size of the pilot (number of participants in the study in comparison to the number of occupants in the building) would not generate any kind of measurable impact on energy savings. In addition, in this phase of the development of BOCS, design interventions to change behaviour and thus to reduce energy consumption are not yet applied.

Two buildings were monitored during the summer pilot, both buildings have been built in the seventies, but the EF building has been renovated. A range on building characteristics was sought in order to test the different data collection methods and solutions, however, the inclusion of a building without natural ventilation was not possible given the lack of enough measuring devices. The main characteristics of the reported monitored building are in Table 1.

	Building EF
Orientation rooms	South-west
Heating system	Active chilled beams
Heating control	Local thermostat (+3, -3)
Cooling system	Active chilled beams
Cooling control	Local thermostat
Ventilation system	Mechanical air handling unit
Openable windows	Yes

Table 1: Main building characteristics of the monitored building.

#### 3.1 Indoor environmental quality

Indoor environmental quality refers to thermal comfort and air quality. Several parameters can affect the thermal comfort in a building. For the purpose of the BOCS evaluation, we focus on three main aspects that can be monitored: indoor temperature (in Celsius), indoor air quality (in CO<sub>2</sub> ppm) and indoor relative humidity.

To evaluate the above-mentioned parameters, we make use of the ASHRAE international standards to determine the range of conditions (Temperature, RH, CO<sub>2</sub> level) in which the building is considered to be comfortable for the majority of occupants. These ranges are shown in Table 2.

The Percentage of People with Discomfort (PPD), based on the PMV or Predicted mean vote, is a model that calculates the percentage of people that will be uncomfortable in the building. However, the PMV only applies to buildings in which the occupants have no control on their environment (e.g. cannot open windows or change temperature settings). Therefore, we use the Adaptive model, in which the acceptable

range of temperature is calculated based on the external temperature.

Following sections show the results of the building performance evaluation of one selected building based on temperature, Relative Humidity, CO<sub>2</sub> level and the adaptive model. The results are presented per monitored room in the EF building.

Building category	Temperature summer (°C)	Relative humidity (%)	CO <sub>2</sub> above external level (ppm)
A	23.5-25.5	30-50	<350
B	23.0-26.0	25-60	35-500
C	22.0-27.0	20-70	500-800

Table 2: Indoor parameters ranges in the standards (ASHRAE 55-2007)[7].

### 3.1.1 Temperature

The ranges of temperature considered acceptable by international standards (ASHRAE) are shown in Table 2 for the summer and winter. The table shows the ranges for each type of building category. The category is defined according to the age and characteristics of the building. The monitored building is in categories B (Renovated buildings). All the figures are shown in percentage of working hours in which the building is within the acceptable ranges.

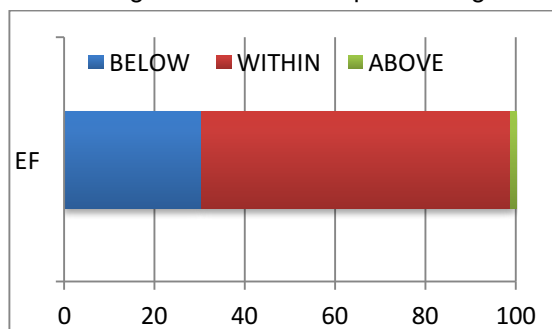

Fig. 2: Percentage of working hours outside accepted range in building.

Figure 2 shows that Building EF is more than 30% outside of the accepted ranges for temperature in the summer. The figure also shows that the building is colder than what is considered acceptable. The offices in this building have local control for the air conditioning, implying that the users prefer lower than accepted temperatures.

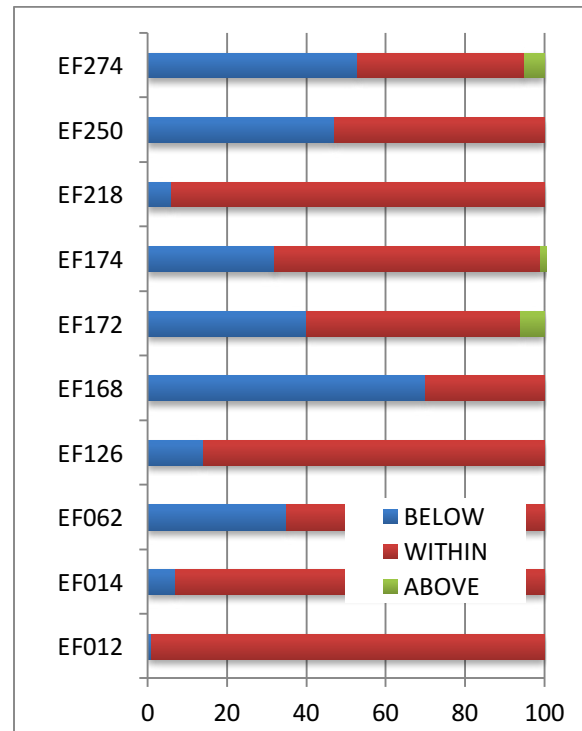

Fig. 3: Percentage of working hour outside accepted range per room.

Figure 3 shows that in some rooms, the temperature below the accepted range can reach up to 70% of the time. On the other side, according to the figures, rooms do not particularly suffer from overheating. Overheating temperatures only occur in three of the monitored offices and for less than 5% of the time. It is important to notice that the EF building has a south orientation, which in theory could cause overheating in the summer.

We can conclude that building EF might be cooled down more than necessary according to the acceptable ranges provided by the international standards. However, research has shown that the actual thermal comfort of buildings' occupants highly depends on the external temperatures. Thus, the following section investigates the performance of the buildings in relation to the adaptive model.

### 3.1.2 Adaptive model

The adaptive model temperature has been calculated per each hour of the monitored period, for which data from a weather station in Valkenburg, South Holland, has been used.

The figure shows the same trend as the results from the temperature ranges: summer indoor temperatures tend to be lower than required, and there is barely overheating during the monitoring period. However, Figure 4 shows that, considering category 2 (C2), the percentage of time that the temperature is lower than required, is small.

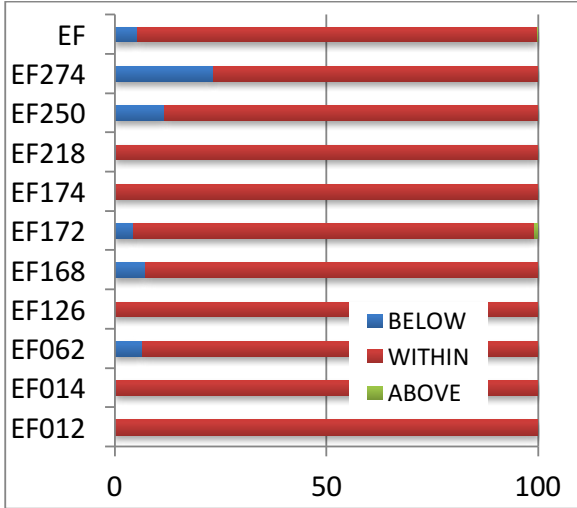

Fig. 4: Percentage of time within adaptive model comfort ranges.

**3.1.3 Relative humidity**

Relative humidity is evaluated based on building category B (healthy range is 25-60%). The relative humidity in all offices is within the accepted values on working hours, with exception of office EF168 where humidity was higher than recommended during working hours for 1.5% of the time.

**3.1.4 CO2 level**

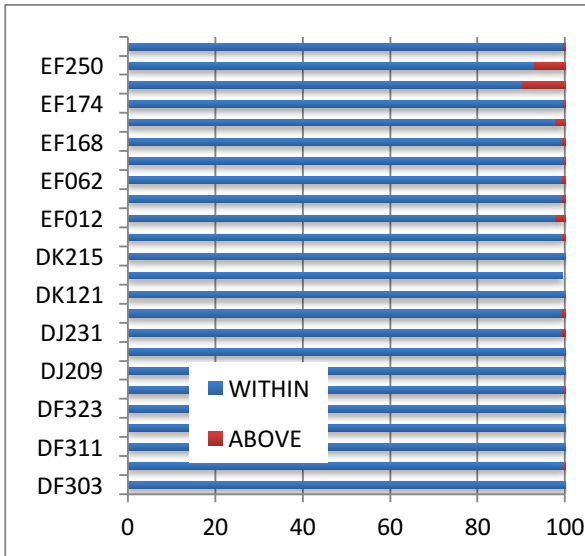

Fig. 5: Percentage of working hours within acceptable CO2 ranges.

Table 2 shows the accepted thresholds for indoor CO2 concentrations in each of the building categories. The results are shown in percentage or working hours within the accepted ranges. Figure 5 shows that the CO2 level is almost always within the accepted range (considering category B) in all offices during working hours. Therefore, we can conclude that the occupants ventilate enough to keep a healthy indoor air quality.

**3.2 Self-reported (subjective) parameters**

The occupants were asked to report on three different parameters: thermal comfort level on a 5 level scale and complains for noise and air quality. In the reported building EF, 18 participants in 8 different offices were recruited. To self-report on thermal comfort, the occupants were provided with a slider on the self-report device. For complains about noise and low air quality, the occupants were provided with a single button for each parameter. The self-reporting device is shown in Figure 2.

**3.2.1 Self-reported (thermal) comfort**

Figure 6 shows the average comfort per each of the participants. The mean represents the average thermal comfort votes reported by each participant. The figure shows that in building EF, all but one person tend to rank their comfort on a positive scale. However, it is not clear whether the occupants understood the icon on the self-reporting device as 'thermal comfort'.

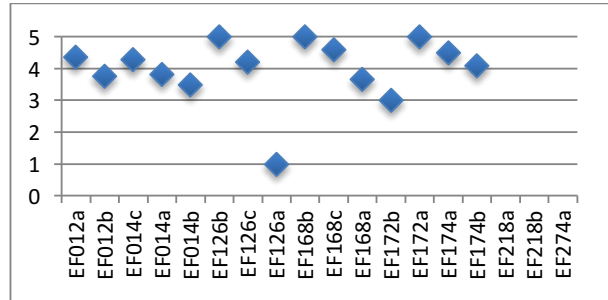

Fig. 6: Average thermal quality votes per participant in building EF.

**3.2.2 Self-reported noise level and indoor air quality**

Figure 7a shows the number of times each participant reported a complain about the noise level in their office. The maximum number of votes over a two week period was 24 votes. Figure 7b shows the number of times each participant reported a complain about the air quality level in their office. The maximum number of votes over a two week period was 26 votes. However, most participants voted less than 10 times. Both figures show that participants using the same room had very different number of complains about noise and air quality, which points at how subjective is this information.

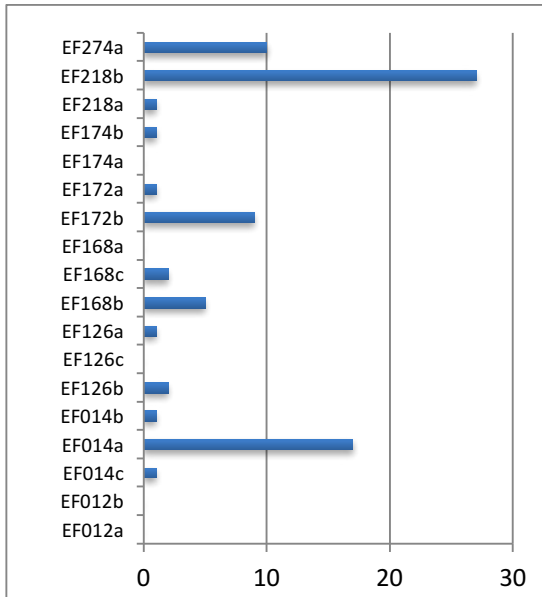

Fig. 7a: Number of complains for indoor air quality for all participants in all buildings.

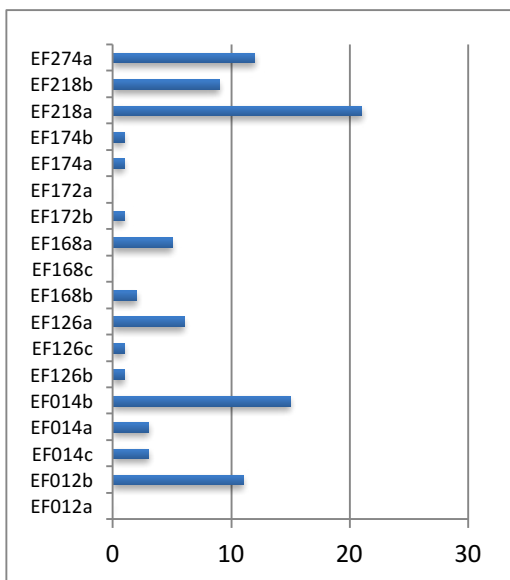

Fig. 7b: Number of complains for noise for all participants in all buildings.

#### 4 DISCUSSION AND CONCLUSIONS

This paper reports on the first pilot of the Building Occupancy Certification System project (BOCS). The project aims at developing a platform to provide relevant building performance and management information to the occupants and managers of commercial buildings.

This pilot aimed at developing and testing devices to collect and analyse relevant data on indoor environmental quality and comfort. The devices had previously been co-designed with a selection of occupants of the monitored building.

The results showed that the objective data collected provided useful information on the indoor environmental performance of the building when coupled with local weather data. The use of

the adaptive model seemed to be more suitable than using temperature ranges provided by ASHRAE, since the high comfort ratings of people indicated that the building was most of the time within comfortable ranges.

The analysis of the subjective data showed several shortcomings in relation to the usability and relevance of the data to evaluate building performance. Firstly, it was not clear whether the participants understood the slider in the Self-reporting device correctly as indicating thermal comfort, since only a happy or sad face was printed on the devices. Secondly, the use of the devices as a 'complaining tool' provided too little information for the analysis, and therefore, it was not possible to analyse the data statistically or in relation to the objective data.

Although the participants indicated, during the co-creation sessions, their desire to only use the self-reporting device when feeling discomfort, it is important to consider for further phases of the study, the limitations of an approach in which the user is given total liberty to design data collection tools. Further iterations of the project will be aimed at provided more reliable subjective data.

#### 5 REFERENCES

1. Joosstens F. and L. Itard, Building management for a good indoor climate and low energy use. How much coordination is needed between facilities manager and technical manager? In proceedings PLEA 2012: Lima, Peru.
2. Consolvo, S., Harrison, B., Smith, I, Chen, M., Everitt, K, Froehlich, J., and Landay, J. (2006). Conducting In Situ Evaluations for and With Ubiquitous Computing Technologies. *Journal of Human Computer Interactions*, 22, 107-122.
3. Intille, S.S., Tapia, E.M., Rondoni, J., Beaudin, J., Kukla, C., Agarwal, S., Bao, L., and Larson, K. (2003). Tools for studying behavior and technology in natural settings. In *Proceedings of Ubicomp'03*. ACM Press, 738-739.
4. Jaskiewicz T. and DV. Keyson, Co-designing with office workers to reduce energy consumption and improve comfort, in proceedings for Behaviour, Energy and Climate Change conference 2015. California, USA.
5. Guerra-Santin O and C. Tweed, In-use monitoring of buildings: An overview and classification of evaluation methods, *Energy and Buildings* 86, 2015, 176-189.
6. Guerra-Santin O and C. Tweed, In-use monitoring of buildings: An overview of data collection methods, *Energy and Buildings* 93, 2015, 189-207.
7. ASHRAE, (2007). Thermal environment conditions for human occupancy. In: ASHRAE Standard 55-2007, ASHRAE Atlanta.



## Expanding Boundaries: Systems Thinking for the Built Environment

### RENOVATION IN AUSTRIA – ANALYSIS OF THE ENERGY PERFORMANCE CERTIFICATES BETWEEN THE YEARS 2006 AND 2015 OF THE COUNTY SALZBURG

M. Prieler<sup>1\*</sup>, M. Leeb<sup>1</sup>, T. Reiter<sup>1</sup>

<sup>1</sup>University of Applied Science Salzburg, Department of Smart Building,  
Markt 136a, 5431 Kuchl, Austria

\*Corresponding author; e-mail: manuela.prieler@fh-salzburg.ac.at

#### Abstract

In Austria funded renovations as well as newly constructed buildings are bound by the issue of an Energy Performance Certificate. Due to that fact, there is a large pool of Energy Performance Certificates which are listed in the ZEUS database for the Austrian county Salzburg

The data basis for this work consists of approximately 40.000 Energy Performance Certificates. The focus of the study is the examination of the renovation's impact on the buildings energy relevant values. Those buildings for which both an Energy Performance Certificate before renovation and after renovation is available are filtered and statistically analysed. There are several studies which statistical analyse different values from Energy Performance Certificates. The major difference to those studies is that within this study the changes of energetic values in the course of renovation are observed for more than 2000 buildings.

The analysis shows that the heating demand obviously decreased in the context of renovation. There is a difference in the reached heating demand after renovation depending on the year when the reconstruction measurements took place. Besides the insulation measurements, renovation often goes along with changes in the heating system. The data analyses showed a clear trend away from the energy source oil for the production of the thermal energy in residential buildings. In return biomass, natural gas, district heating and electricity for the operation of heat pumps become more important.

#### Keywords:

Energy Performance Certificate; Renovation; Heating demand; U-value

## 1 INTRODUCTION

The Energy Performance Certificate (EPC) parameters heating demand and energy performance factor have integrated into everyday life, because these values have to be mentioned in any real estate listing based by law [1]. Every new building and funded renovation is bound by the issue of an EPC in Austria. Based on these facts there is a large pool of EPC. For the county of Salzburg the EPC are listed in the ZEUS database.

The data basis for this work consists of approximately 40.000 EPC. This is the amount of EPC which was uploaded to ZEUS in the period 2006 to June 2015.

The focus of the study is the examination of the renovation's impact on the buildings energy relevant values. In this context, those buildings for which both an energy performance certificate before and after renovation is available are filtered and statistical analysed. For this study, only the residential buildings where an EPC before and after the renovation exists are considered and compared with the values of the analysis from new buildings.

This work differs from other statistics on EPC, such as [2] and [3] to the effect that the focus here is the comparison of the renovation to inventory. Also the considered population differentiate, in this work the EPC of the province of Salzburg are analysed. Furthermore, this study distinguishes

from [4] and [5] at the high amount of analyse EPC concerning the existing building stock. The distinction to [6] and [7] is the expanded period under observation and the different research questions.

## 2 METHODS AND DATA BASIS

In several cases EPC are multiple uploaded into the ZEUS database for different purposes, e.g. for different funding programs. Also, there are EPC which are not plausible in ZEUS. Consequently, it is necessary to make a pre-analysis of the data before starting the actual data analysis. Concerning the plausibility check of the data, a model was developed which restricts the range of values. In this context, it was determined which values are possible and plausible for each variable. For the description and analysis of the data, methods from the field of descriptive statistics are used.

After validating the EPC and considering multiple entries of the same EPC in the database the data basis is reduced to 35,230. This amount includes the EPC for all categories of buildings.

The comparison of inventory and restoration in this work only includes the EPC before renovation (inventory) to the EPC after renovation (restoration completion) of residential buildings. By filtering this data, the data basis for the statistical analysis is reduced to 4,460 EPC (2,230 inventory and 2,230 restoration completion).

The comparison of the renovation with the construction (new building) is carried out with all the latest valid construction completion EPC. In the event that several EPC are available for a construction object, the newer EPC is taken into consideration (= last valid). The number of latest valid new building EPC is 2,146.

## 3 RESULTS

### 3.1 Heating demand before and after renovation

A frequently used parameter for the evaluation of the energy performance of buildings is the heating demand. The heating demand can be distinguished between two bases, namely reference climate and location climate. In this work only the heating demand at the location climate is considered. This parameter was chosen for the statistical analysis based on its importance in the context of the zoning law and the residential building subsidies.

The comparison of the specific heating demand between inventory and restoration is shown in Figure 1 with histograms. The specific heating demand is illustrated by the x-axis, the y-axis shows the frequency of the values. For the purpose of a better illustration, only values of the heating demand in the range 0 - 425 kWh/m<sup>2</sup>.a are

shown. These are sporadic higher values, such as the maximum of 745.87 kWh/m<sup>2</sup>.a of the inventory, which are not seen. But these high values are considered by calculation of the median, the mean and the standard deviation.

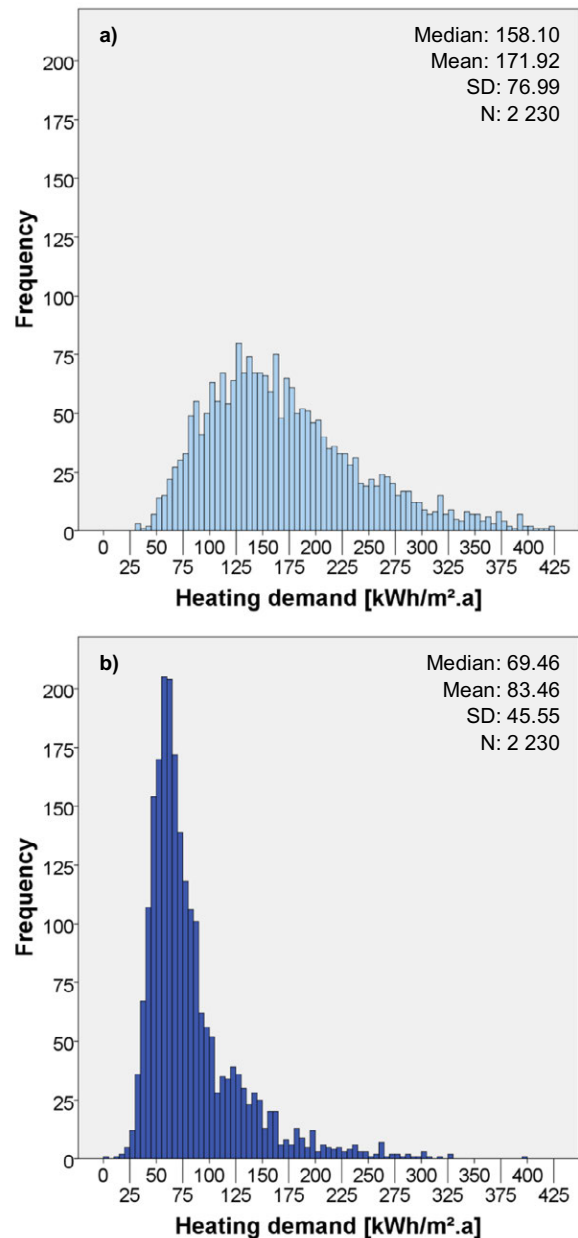

Fig. 1 : Heating demand before renovation (a) and after renovation (b)

The histogram for inventory shows that the heating demand is widely spread, mostly in the ranges between 70 kWh/m<sup>2</sup>.a and 240 kWh/m<sup>2</sup>.a. After renovation the heating demand has obviously been reduced and is located mainly in the field 40 kWh/m<sup>2</sup>.a to 90 kWh/m<sup>2</sup>.a. The median of the heating demand is 158.10 kWh/m<sup>2</sup>.a for inventory and 69.45 kWh/m<sup>2</sup>.a after renovation. In comparison: the median of the heating demand of new buildings is 40.89 kWh/m<sup>2</sup>.a, the average value 42.37 kWh/m<sup>2</sup>.a and standard deviation 16.18 kWh/m<sup>2</sup>.a.

Figure 2 shows the reached heating demand depending on the year when the renovation was done. The lower whisker at the box plots show the smallest heating demand after renovation. The beginning of the box indicates the lower quartile and therefore the position of the 25% lowest values. The line within the box shows the location of the median and the end of the box the upper quartile. The rings and stars above the upper whisker are outliers. The red line shows the median of the heating demand independent from the year of renovation.

By looking at the position of the median, it can be seen that the date when the renovation happened has an influence on the heating demand. The reached heating demand in the more recent past is lower as if the renovation measurements took place in the further past. A reason for this result can be the more and more strict regulations by law and the funding guidelines in the field of building. Notable is also that in the former past the standard derivation of the reached heating demand after renovation is decreasing. Besides the stricter regulations another reason for this result can be that the state of the art is changing.

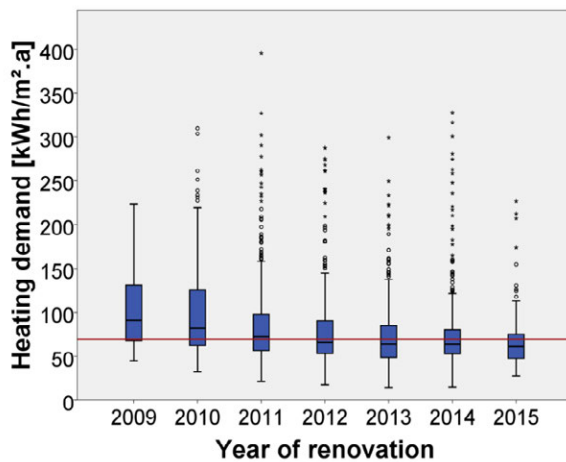

Fig. 2 : Comparison of the heating demand after renovation, depending on the year of renovation

### 3.2 U-value before and after renovation

During the renovation, the average heat transfer coefficient (U-value) of the residential building has clearly been reduced. The U-value is a relevant parameter for the characterization of the quality of the outer casing and therefore for the construction technology of the buildings.

While the median by inventory is  $0.82 \text{ W/m}^2\text{.K}$ , it is  $0.38 \text{ W/m}^2\text{.K}$  after the renovation and so has decreased significantly, in fact it has more than halved. In comparison, the median of the average U-value by construction is  $0.25 \text{ W/m}^2\text{.K}$ . The distribution of U-values of inventory and restoration can be seen in Figure 3.

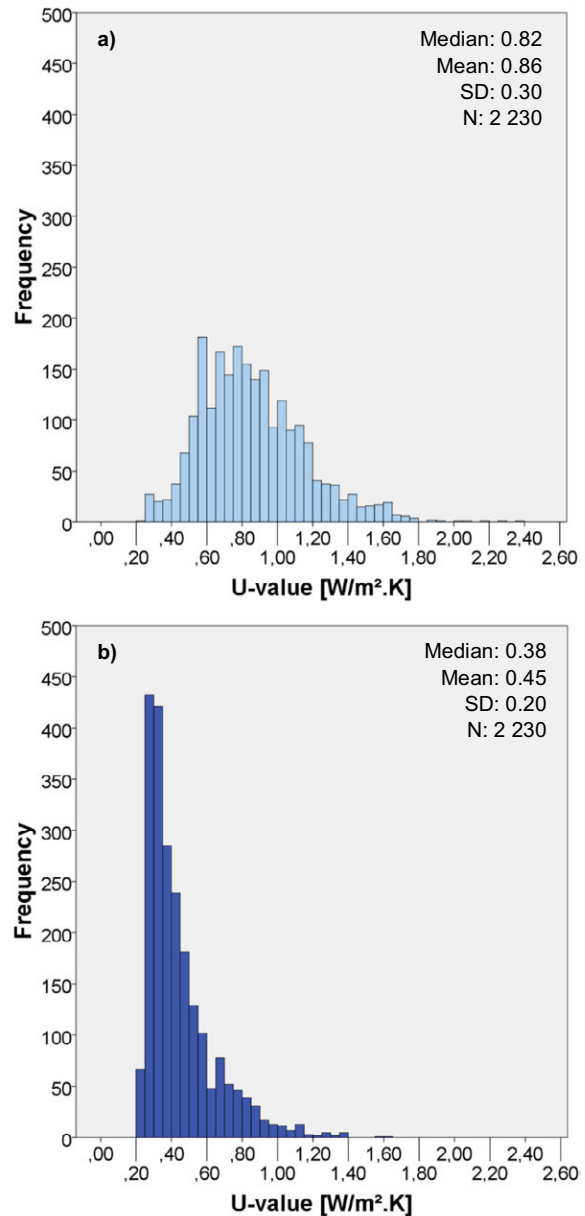

Fig. 3 : U-value before renovation (a) and after renovation (b)

A comparison between the U-value of the considered restoration completion and the new building is shown in Figure 4. This visualisation reveals how far the reached standard of renovations differs from new buildings. It should be noted that for the purpose of better illustration, the scale for the average U-value (x-axis) was limited to  $1.0 \text{ W/m}^2\text{.K}$ .

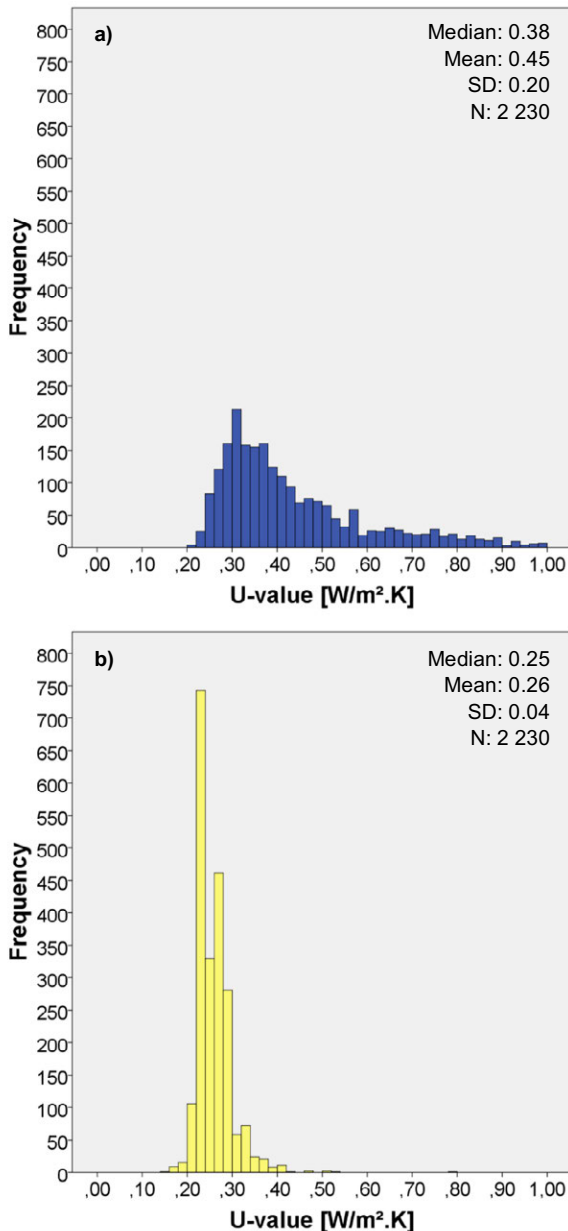

Fig. 4 : U-value after renovation (a) compared to the u-value of new buildings (b)

The comparisons showed clear differences between the standard of buildings before and after renovation as well as for new buildings based on the U-value. Unfortunately, information about the building components are not implemented in the ZEUS database yet. Hence it is not possible to analyse the material changes while renovation and the difference to new buildings. In the near future, a new XML-version of ZEUS will be released. There will be variables implemented for the layers of all the structural components of buildings. So it is a matter of time till it is possible to analyse what construction and insulation materials are used in which thickness and which position in the field of reconstruction and at new buildings.

### 3.3 Energy sources before and after renovation

During the renovation, the used energy sources have changed by 19 % in residential buildings. In this context it must be mentioned that changes in the heating system are not bound to creating an EPC, even not in the context of residential building subsidies. The most widely used energy source in the considered data is oil, followed by biomass. This applies to both, inventory and after renovation (see Figure 5).

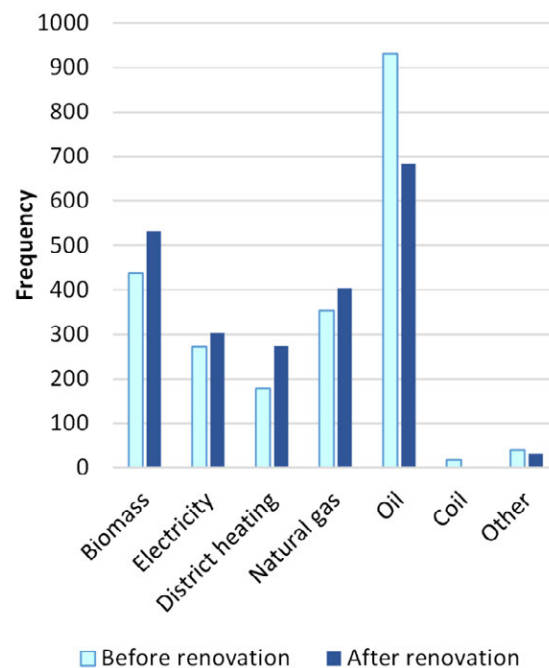

Fig. 5 : Used energy sources before and after renovation

After renovation, often other energy sources are used instead of oil for generating the needed thermal energy. At inventory 42.1 % of the heating systems were operated with fuel oil, after the renovation, the percentage has been reduced to 30.9 %. The share of biomass has increased from 19.8 % to 24.1 %. In addition to biomass, also a significant increase in district heating and natural gas compared to the initial situation are determined. An increase is also reflected in electricity (+ 11.8 %). The change in power is due to the increased use of heat pumps.

Figure 6 shows that exclusively the implementation of heat pumps has led to an additionally use of electricity for heating purposes. It turns out that the use of heating with heat pumps has increased by approximately 357 % compared to the starting position. The use of direct electricity systems has been reduced by 22.6 % and the use of night storage heaters by 42.9 %.

A main difference between direct a electricity system and night storage heaters is the time



period when the electricity is consumed to produce heat. Night storage heaters consume electricity at low load periods when the electricity tariff is keen, commonly at night and store the heat for several hours. For night storage heater, a power meter is needed which distinguishes between the electricity consumption at time of normal tariff and low tariff (night tariff). While in former days, there was a big difference between the tariffs night storage heaters were quite popular. Nowadays, the night tariff is not much cheaper than the normal tariff. Furthermore, in this days there are many electricity suppliers which do not even offer a night tariff.

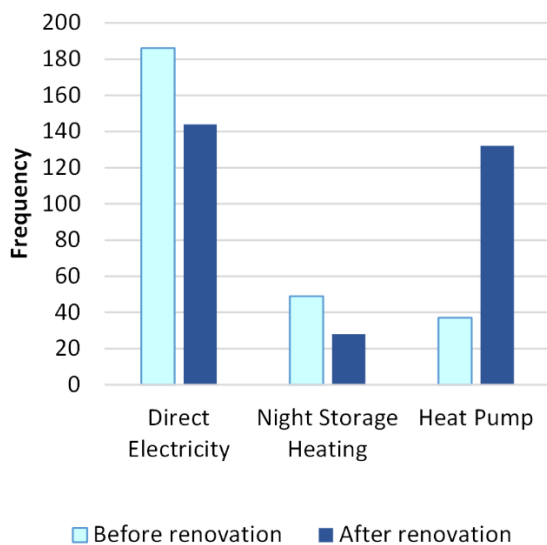

Fig. 6 : Heating systems with energy source electricity

The insert resources by new buildings are not the same. There the most important source of energy is electricity with 29.6 % (for operation of heat pumps) followed by biomass (27.1 %) and district heating (24.1 %). The use of fuel oil to provide the necessary thermal energy has only a proportion of 2.2 % at new buildings in Salzburg.

#### 4 CONCLUSION

In this work the impact of renovation on energetic values was analysed by comparing the EPC before and after reconstruction of more than 2000 buildings. An evaluation of renovation in this way with such a high amount was done in this study the first time.

The study showed that renovation has a significant impact on the energy values of buildings. In line with this, the U-value of the compared residential buildings has been reduced by more than half, related to renovation. Hence there is a significant reduction of the heating demand of the buildings after renovation too. It is notable that the reached heating demand

differentiate depending on the year when the renovation took place. Based on the fact that the heating demand is gathered from the EPC, this value matches a requirement and not a consumption.

A look at the used energy sources shows that renovation cannot only be linked to insulation work. During the renovation, the used energy sources changed by 19 % of residential buildings. Before renovation more than 40 % of the analysed residential buildings had implemented an oil heater. After renovation in particular, biomass, district heating, natural gas and electricity for the operation of heat pumps are increasingly used for the production of thermal energy.

When interpreting the results, it should be noted that only those residential buildings were evaluated where an EPC before and after renovation was available in the ZEUS database. Inventory (before renovation) is not necessarily equal to the original state at the time of construction. It is quite conceivable that the existing building has been renovated before. The inventory EPC might be calculated for a funded renovation and compared in this study with the restoration completion EPC (EPC after renovation). In the past there was no obligation to upload each EPC in the ZEUS database. So it has to be assumed that not each EPC exists in ZEUS. However, if there was an application for funding of the renovation, the EPC is available in ZEUS, thus is considered in this data analysis. Last but not least it has to be taken into account that measures such as changing the heating system are not bound by the issue of an EPC.

The amount of EPC in ZEUS will increase steadily. Hence in the future there will be a much higher amount of EPC available for such statistical analysis. To improve the quality of the database and the opportunities to generate insights from the data, the knowledge of this statistical analysis is taken into account by the further development of ZEUS. In the near future a new XML-Version will be released. There will be variables implemented for the layers of all the structural components of buildings, as an example. So in the future it will be possible to monitor a high amount of EPC where building components have changed in the context of renovation.

#### 5 ACKNOWLEDGMENTS

The data and the basis of this summary are from the research project "Alternative Wege zum Nullenergiehaus" with partial funding of the Trans4Tec program, Salzburg. The authors are grateful to the Government of Salzburg and gizmocraft, design and technology GmbH, that ZEUS could be used as data basis.

## 6 REFERENCES

1. Bundesgesetz über die Pflicht zur Vorlage eines Energieausweises beim Verkauf und bei der In-Bestand-Gabe von Gebäuden und Nutzungsobjekten (Energieausweis-Vorlage-Gesetz 2012 -EAVG 2012),. BGBl. I Nr. 27/2012
2. Brunn M. and Liepert M, Energieausweiszentrale Jahresbericht 2012. 2013, [https://www.eawz.at/Daten/Bilder/Infos/EAWZ\\_Jahresbericht\\_2012.pdf](https://www.eawz.at/Daten/Bilder/Infos/EAWZ_Jahresbericht_2012.pdf)
- 3 Dascalaki E. et al., Energy verification of Hellenic buildings: First findings, Energy and Buildings, 2013. Volume 65: p 429-437
4. Dascalaki E. et al., Data collection and analysis of the building stock and its energy performance – An example for Hellenic buildings, Energy and Buildings, 2010. Volume 42, p 1231-1237
5. Loga T. et al: Datamine: Collecting Data from Energy Certification to Monitor Performance Indicators for New and Existing buildings. 2009, <https://ec.europa.eu/energy/intelligent/projects/sites/iee-projects/files/projects/documents/datamine.pdf>
6. Prieler M. et al., Sanieren in Salzburg – Analyse der Energieausweise vom Bundesland Salzburg der Jahre 2006 - 2014, in International Conference on high quality retrofit and redensification with timber construction systems. 2015: Graz, Austria
7. Prieler M. et al., Sanierung und Gebäudetechnik - Analyse der Energieausweise vom Bundesland Salzburg der Jahre 2006 – 2015, in e-nova 2015: international congress for sustainable buildings. 2015: Pinkafeld, Austria



## Expanding Boundaries: Systems Thinking for the Built Environment

### ECOLOGICAL FOOTPRINT ANALYSIS OF CANADIAN HOUSEHOLD CONSUMPTION BY BUILDING TYPE AND MODE OF OCCUPATION

C. Jouaneau<sup>1</sup>, M. Dupuis<sup>1</sup>, N. Grunewald<sup>2</sup>, C. Ouellet-Plamondon<sup>1\*</sup>

<sup>1</sup> Ecole de Technologie Supérieure, Montreal, Canada

<sup>2</sup> Global Footprint Network, Geneva, Switzerland,

carl.jouaneau.1@ens.etsmtl.ca

\*Corresponding author; e-mail: claudiane.ouellet-plamondon@etsmtl.ca

#### Abstract

This paper expands the system boundaries of the residential built environment to the Ecological Footprint (EF) in Canada. The proposed methodology is applied in two steps. First, we compare the household expenditures according to building type. These differences account for the varying resource requirements of households residing in different types of building. Second, the EF of the household consumption is calculated with a multiregional input-output model based on the Global Trade Analysis Project. The study is based on data from Statistics Canada, from the annual survey of household expenditures and according to four different building types (single detached house, single attached house, apartment and others) and different modes of occupation (owner with mortgage, owner without mortgage and renters). The resource requirements are derived from household expenditures and reclassified according to the Classification of Individual Consumption According to Purpose category of the United Nations Statistics Division (COICOP) and according to the Consumer Land Use Matrix, which displays resource requirements from final household demand by consumption categories (food, housing, transport, goods and services). The paper provides insights on how to drive the consumption in order to have a reduced EF not only in terms of daily needs, but also on how the housing type and the mode of occupation have an impact on resource requirements. The methodology can be used to analyse and to compare the design of residential buildings in order to generate economic policies in various countries and to encourage citizens to take responsibility for their choice of residence.

#### Keywords:

Ecological Footprint; Top-down analysis; Residential building; Household expenditures; Mode of ownership; COICOP

## 1 INTRODUCTION

Reducing environmental impacts through sustainable use of natural wealth is an important challenge for governments and decisions makers around the globe (Kitzes and Wackernagel, 2009) [1]. According to the most recent studies, the resources of 1.7 Earth equivalent are necessary to support our current consumption (Global Footprint Network (GFN), 2015) [2]. This situation, referred to as overshoot (Wackernagel and Rees, 1996) [3], means that our consumption is currently so intensive that the ability of the ecosphere to regenerate is altered (Galli, 2015)

[4]. Since the early 1960's and the industrial era, consumption in developed countries has exploded and cities have become the nerve centres of our society (Moore and al., 2013) [5]. Managing resources in urban areas is a big challenge, but it would provide natural wealth for future generations and represents a source of economic, social and, of course, environmental influence (Mackenzie and al., 2008) [6]. Accumulation of human pressure on ecosystems is fundamental to many environmental problems and world leaders face the challenge of selecting appropriate measures and policies to prevent

further ecological disasters (Wackernagel and al., 2006 ; Sutton and al., 2012) [7] [8].

According to several studies in different parts of the world, household consumption holds a large place in the global ecological impact of a nation (Holden, 2012; Gressot and al., 2015) [8] [9]. The world population has increased faster for decades and is foreseen to achieve 9 billion by 2050 with 67% of which is expected to live in urban areas (FAO, 2009) [10]. In order to reduce climate changes, pollution and to preserve the biosphere, it is necessary to monitor and to regulate such demand of natural capital (Borucke and al., 2013) [11].

Despite some criticisms (Kitzes and al., 2009) [12], a concrete indicator is necessary to quantify and qualify the use of natural resources and the Ecological Footprint (EF) is one of the most common. Using standardized measurements, the Ecological Footprint was introduced by William Rees and Mathis Wackernagel in the 1990s (Rees, 1992 ; Wackernagel, 1994) [13] [14]. It measures the area of biologically productive land and water required to support the demands of a population or its production capacity. Such areas compound the six components of the EF: cropland, grazing land, forest land, fishing grounds, built-up land and carbon zone. Based on the fundamental assumptions that most of the consumed resources and waste production can be tracked (Wiedmann and al., 2007) [15], this demand can be compared to biocapacity (Butchart and al., 2010) [16], the amount of biologically productive land and water available for human use. The measurement units are global hectares, gha, corresponding to one hectare of biologically productive space with world average productivity for the given year (Galli and al, 2007) [17].

Different approaches have been performed in order to head toward a sustainable world and surveys highlight several factors influencing the human pressure in cities such as design, size, or the localization of the residential areas (Jin, Xu and Yang, 2009 ; Holden, 2004) [18] [19]. Based on a single top-down approach to consistently track the EF inside a high-density area, E. Holden presented studies in Norway analysing the structure of a sustainable town, comparing a city located in an urban area to one in a rural environment (Holden, 2012) [20]. This approach is applied in this article for the first time in Canada, for 4 different building types, including the mode of occupation. The aims of this study are to compare EFs from different types of building and from different modes of occupation in order to involve population in consuming more responsibly and to encourage a more energy-efficient design of the residential areas.

## 2 DATA AND METHOD

### 2.1 Data

Raw data has been acquired from Statistics Canada for the 2010 to 2013 period from the Survey of Household Spending (Statistics Canada, 2015) [21]. Detailed average household expenditures from everyday life have been classified in 16 principal categories (food, shelter, household operations, household furnishings and equipment, clothing and accessories, transportation, health care, personal care, recreation, education, reading materials and other printed matter, tobacco products and alcoholic beverages, games of chance, gifts, financial services). These categories are inspired from those created by the United Nations Statistics Division, the COICOP classification (United Nations Statistics Division, 2015) [22]. All expenditures are in \$CA.

Expenditures have been extracted according to the building type and the mode of occupation. The four building types studied are single detached houses (building usually occupied by a single household and consists in a single dwelling unit), single attached houses (home sharing a common party wall), apartments and, other types of location (hotel, rooming, lodging house, construction camp or mobile home for example). The three modes of occupation studied are owner with mortgage, owner without mortgage and renter. Household spending on income taxes is not integrated in the study.

### 2.2 Consumption Land Use Matrices

Evaluation of EF requires tables provided by the Global Footprint Institute, the Consumption Land Use Matrices (CLUMs). The CLUM-GTAP8 indicates the EF associated with purchases from the major consumption categories. It is unique to the economic system of a country, and can often highlight surprising findings that reveal important underlying features of a nation's consumption and its impact on ecological systems (GFN, 2015) [2]. Within the CLUM, there are two broad classifications:

- Areas that are under direct influence of households, such as direct consumption under the broad categories of food, shelter, transportation, goods, and services.
- Areas that are under indirect influence of households, such as gross fixed capital formation and government expenditure.

In GTAP, the Gross Fixed Capital Formation does not have a link with citizen expenditures. As Canada is a democratic country, government's EF is the same for each citizen. Results do not include the GCFC and EF from the government.

### 3 METHODOLOGY

The classification from Statistics Canada differs from those used in the CLUM. Indeed, food, shelter and transportation are the same for both categorizations but goods and services in CLUMs differ slightly from Canadian expenditures. A database and different comparison tables have been created to link the most detailed level of Canadian categories to the five major groups of the GFN. Surveys using this linkage have been previously done (Calgary and Global Footprint Network, 2007) [23] in Calgary.

In order to monitor our results according to the type of building (Fb) and the mode of occupation (Fo) several factors have been calculated. EFs per capita have been obtained by dividing the total expenditures for each category by the size of the household. Each factor is calculated as:

$$Fb = \frac{\text{Households expenditures (type of building)}}{\text{Total expenditures (all dwelling)}} \quad (1)$$

$$Fo = \frac{\text{Households expenditures (mode of occupation)}}{\text{Total expenditures (all dwelling)}} \quad (2)$$

Calculations using the Canada given CLUM and the ranged expenditures can be made (Galli, Kitzes and Wermer, 2007) [24] and allow to give us the Ecological Footprint for each category of the classification. At the final stage of our expenditures classification, we will get CLUMs with footprints organised by COICOP consumption categories sectors of expenditures for each type of building and mode of occupation.

### 4 RESULTS

Survey results have been obtained by Statistic Canada from the Survey of Household Spending for the 2010-2013 periods. Size of households varies from 1.8 in apartments to 3.1 residents per household in single detached houses. In 2010, 11,746 persons were in the sample and this represents a weighted estimate of 13,514,008 households with an average size of 2.48 persons per household.

#### 4.1 Expenditures and EF analyses depending the type of building

Figure 1 presents household expenditures (in \$CA) according to the type of building from 2010 to 2013 and to the five categories of consumption. Households living in single detached houses spend more money than the others, and in average, household they spend 83,600 \$CA per year, households in single attached houses spend in average 70,375 \$CA, followed by those living in apartments (50,455 \$CA) and in other types of building (47,890 \$CA). The main expenses for Canadian households are in housing (35% for apartments to 44% of the total expenditures for SD houses) and services (22% for SD houses to 27% for apartments).

Transportation, goods and food (respectively 11% to 15%, 12% to 15% and 09% to 11%) are minor parts of the expenditures.

As we can notice, expenditures have increased every year, especially for single detached houses and apartments. Over these four years, Canada has been impacted by inflation. All household fees increased during this period.

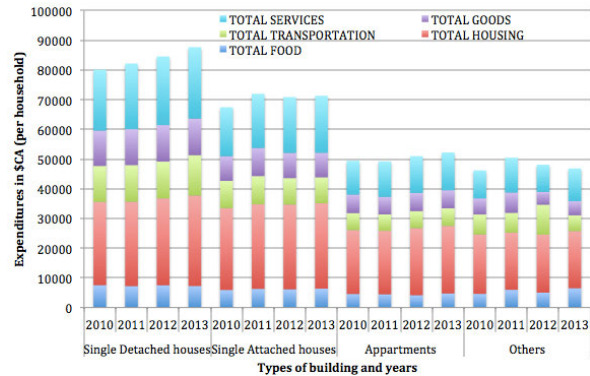

Fig. 1: Households expenditures according to the type of building from 2010 to 2013.

Figure 2 shows us the Ecological Footprint per capita for the different types of building studied. Consumption from single detached houses households generates the highest EF with an average footprint of 6.3 gha per capita for the years 2010-2013. Inhabitants from single attached houses have an average EF of 4.9 gha per capita and occupants from other types of building have an average EF of 3.7 gha per capita. Finally, dwellings living in apartments generate the lowest EF (3.2 gha per capita).

Despite to the variation in expenditures, most of the expenses are spent in housing and services sectors. Transportation and food are the main drivers for the EF of Canadian households. They are respectively part of 36% and 22% of the total EF whereas, goods, housing and services represent 17%, 14% and 10% of the total EF.

Transportation is the main driver of the Canadian households for all types of building. Purchase and maintenance of vehicle are responsible for more than 80% of the transportation EF. SD houses occupants have the greatest impact, followed by inhabitants of SA houses, other types of building, and dwellings living in apartments. Food is the second sector with the highest EF for Canadian households' consumption, regardless to the types of building. This sector represents between 20% and 24% of the total EF and is driven by the meat and the animal-origin food, and this for all the different types of building.

Bigger buildings consume more energy (electricity, gas and other fuels for heating for example) and gather more people in one household. The housing EF rises with the size and the type of building.

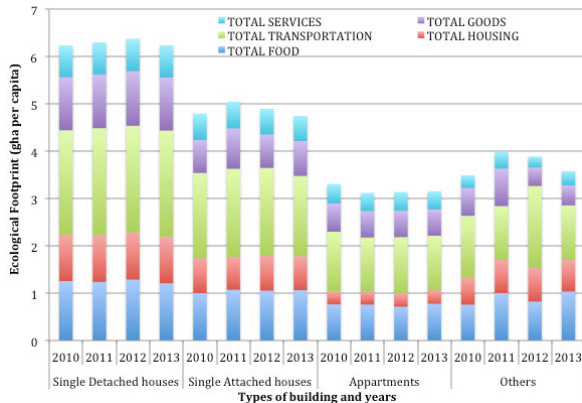

Fig. 2: Ecological Footprint according to the type of building from 2010 to 2013.

### 4.2 Expenditures and EF analyses depending on the mode of occupation

In average, owners with a mortgage spend 99,600 \$CA per year, owners who do not have one spend 62,100 \$CA (in average 82,500 \$CA for owners, that is more than 1,5 times more than the renters (49,800 \$CA) (Fig. 3). Main expenses for Canadian households still concern housing and services sectors.

Owners who have a mortgage have more fees to pay than those without a mortgage, especially in the services and housing category. These fees mainly correspond to the financial services and taxes related to household management. Renters pay less for these, but are responsible for their energy consumption, major part of their expenses in the housing sector. Only 62% of renters are car owners. Expenditures allowed for transportation are far less than owners and are 22% of their total consumption whereas it represents 28% of the total for the owners.

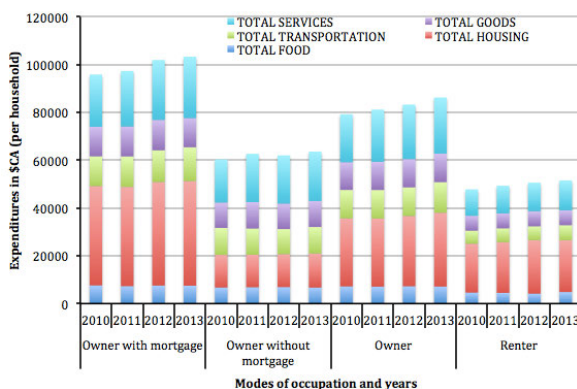

Fig. 3: Household expenditures according to the modes of occupation from 2010 to 2013.

Owners without mortgage have the highest EF (average value of 6.5 gha per capita). Owners with mortgage have a reduced one (5.6 gha per capita in average) compared to those with mortgage, but the part of the owners is really more important than the renters one. The EF from the owners' consumption is 1.8 times the one of the renters (respectively 6.1 and 3.3 gha

per capita). Transportation and food have the greatest impact on EF, even depending to the mode of occupation (Fig. 4).

In the transportation field, the EF generated is mainly due to the rate of car ownership. Whereas only 62% of the renters have a car, the rate of owners of a dwelling having a car exceeds the 95%. The EF associated for the owners is almost twice the one of the renters, and reducing it becomes the main goal. According to the figures, the expenditures and the EF embedded to the housing sector are much higher for owners than the ones for renters. Even if their footprint in the sector of housing is over three times below the owners' ones, it is important that they should be aware of their impact.

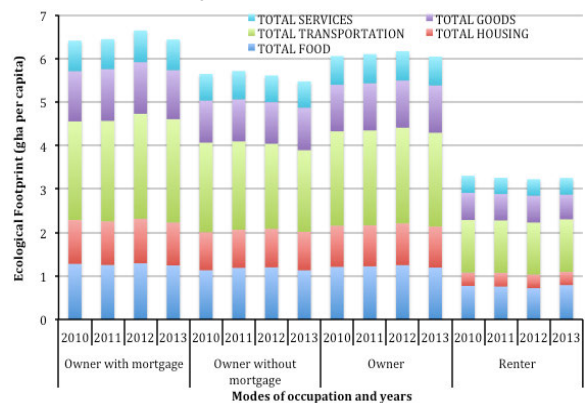

Fig. 4: Ecological Footprint according to the modes of occupation from 2010 to 2013.

### 4.3 Ecological Footprint in term of land use

The largest part of the EF is due to personal transportation on a personal scale (Figure 5). Food and goods follow this trend and so does housing. Carbon Footprint for personal transportation is the single most important driver of the total footprint, followed by the cropland footprint for food consumption and the carbon footprint for housing. The carbon footprint or "energy land" represents between 52% and 55% of the total footprint.

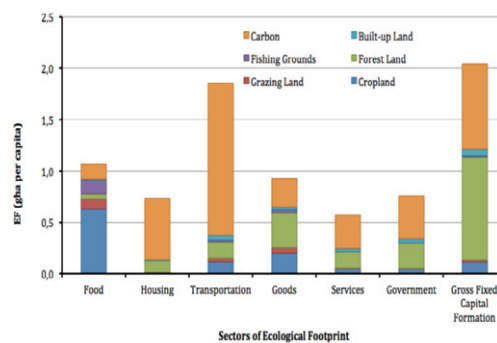

Fig. 5: Consumption Land Use Matrix (CLUM) breakdown for Canada in 2010, indicating ecosystem types mostly demanded by Canadian households.

## 5 DISCUSSION AND CONCLUSION

The top-down (MRIO-based) Ecological Footprint approach presented in this paper allowed for the first time to study the link between the income, the type of building and the mode of occupation. In Canada, the Ecological Footprint of people living in single detached houses is twice as high as the EF of people living in apartments. Those living in a property with a mortgage have an EF twice of those renting. Overall, we found that the main drivers of the EF were transportation, then food regardless of the types of building and the modes of occupation of the Canadian households. However, the income, the size of the household, and the location of the dwelling are the main factors that influence the EF (Rees and Walker, 1997) [25]. Centralization of the activities to avoid transportation impacts and high-density cities could lead to smaller Ecological Footprints of Canadian households (Biesiot and Klaas, 1999) [26].

In Canada, even if households spend more money on housing and services; the main share of EF is due to transportation and food. Canada is a large country and modes of transportation have not changed in decades. Most inhabitants have their own car (Transport Canada, 2013) [27], and especially for those living in single detached houses, usually located outside of the cities. Living in apartments and renting have a lowest impact when it comes to transportation and other categories. Food is not the main category for expenditures, but has a large impact on total EF. Canada import a large quantity of food supply, so local consumption requires more resources than if produced locally.

Housing and especially energy is largely due to the size of habitation. When we compare the footprint allocated to the housing category, EF for single attached houses is more than twice the apartment ones. Heating and maintenance of the dwelling generate more impact; more money is also spent in these sectors for single attached and single detached households, whereas rentals for housing expenditures are higher for whom living in apartments. It is also largely taken over by the owners. So does work the heating: renters are not necessary allowed to regulate the heating and not even responsible for the energy fees. In order to involve the renters into environmental and more sustainable practices, sharing of the energetic fees between owners and tenants could have a positive effect and make the renters reduce their consumption.

With a novel approach, this ecological indicator is used for different types of building linked to the type of the households. This combination allows a more accurate analysis of the households' consumption according to residential building type and mode of occupation, and its correlation on ecosystem impacts. Transportation has the

larger impact and is mainly responsible for the carbon footprint of the Canadian households. Public transport has to be developed near the main centres of activities, and prices for fuel have to be risen in order to promote low-carbon emission energies (Rees and Wackernagel, 1996) [28]. Promoting low-protein food, reducing the amount of meat and dairy products and diminishing food waste are important to succeed in the reduction of the EF associated to the production, the consumption and the waste generated by the food. Housing footprint could also be reduced by planning ecological construction (LEED certification), by constructing high-density areas that concentrates transportation, commercial areas and population.

Households' consumption awareness is critical. This paper highlights that living in single detached houses with a mortgage is the biggest resource driver, as compared with the lower impact of renting an apartment. Public policies must encourage citizens to take responsibility for their choice of residence and their allocation of expenditures toward sustainable goals.

## 6 ACKNOWLEDGEMENT

The CLUM-GTAP8 was kindly provided by the Global Footprint Network.

The author would like to thank a reviewer from Statistics Canada.

Mathis Wackernagel and Jon Martindill are thanked for the discussion on EF methodology.

in the papers appearing in the SBE 2016 regional conference. The layout and style presented on these instructions should be used when preparing your paper. The paper must be sent in MS Word *docx* or *doc* format. The official language of the Conference is English. Papers written in other languages will not be accepted. The final paper must not exceed **2500 words** in length not including references. Every paper will be numbered separately. Please leave the numbers in the footer and do not modify it.

## 7 REFERENCES

1. Kitzes, Justin and Mathis Wackernagel. 2009. « Answers to common questions in Ecological Footprint accounting ». Ecological Indicators, vol. 9, no 4, p. 812–817
2. Global Footprint Network. 2015. « Global Footprint Network ». In Global Footprint Network. <<http://www.footprintnetwork.org/en/index.php/GFN/>>. Consulté le 8 janvier 2016.
3. Rees, William and Mathis Wackernagel. 1996. « Urban ecological footprints: Why cities cannot be sustainable—And why they are a key to sustainability ». Environmental Impact Assessment Review, vol. 16, no 4–6, p. 223–248.

4. Galli, Alessandro. 2015. « On the rationale and policy usefulness of Ecological Footprint Accounting: The case of Morocco ». *Environmental Science & Policy*, vol. 48, no 0, p. 210–224.
5. Moore, Jennie, Meidad Kissinger and William Rees. 2013. « An urban metabolism and ecological footprint assessment of Metro Vancouver ». *Journal of Environmental Management*, vol. 124, no 0, p. 51–61.
6. Wackernagel, Mathis, Justin Kitzes, Dan Moran, Goldfinger Steven and Mary Thomas. 2006. « The Ecological Footprint of cities and regions: comparing resource availability with resource demand ». *Environment and Urbanization*, vol. 18, p. 103–112.
7. Sutton, Paul, C. Anderson, Lauren Morse, J. Sharolyn and Benjamin Tuttle. 2012. « The real wealth of nations: Mapping and monetizing the human ecological footprint ». *Ecological Indicators*, vol. 16, no 0, p. 11–22.
8. Holden, Erling. 2004. « Ecological footprints and sustainable urban form ». *Journal of Housing and the Built Environment*, vol. 19, no 1, p. 91–109.
9. Gressot, M., N. Grunewald, W. Baabou, C. Ouellet-Plamondon, A. Galli and K.Iha. 2015. « The Ecological Footprint of Mediterranean Cities: Awareness and Policy Implications ». In *The 5th World Sustainability Forum*. (septembre 2015).
10. FAO. 2009. *Global Agriculture towards 2050*. Rome. <[http://www.fao.org/fileadmin/templates/wfs/doc s/Issues\\_papers/HLEF2050\\_Global\\_Agriculture.pdf](http://www.fao.org/fileadmin/templates/wfs/doc s/Issues_papers/HLEF2050_Global_Agriculture.pdf)>.
11. Borucke, Michael, David Moore, Gemma Cranston, Kyle Gracey, Katsunori Iha, Joy Larson, Elias Lazarus, Juan Carlos Morales and Mathis Wackernagel and Alessandro Galli. 2013. « Accounting for demand and supply of the biosphere's regenerative capacity: The National Footprint Accounts' underlying methodology and framework ». *Ecological Indicators*, vol. 24, no 0, p. 518–533.
12. Kitzes, Justin and Mathis Wackernagel. 2009. « Answers to common questions in Ecological Footprint accounting ». *Ecological Indicators*, vol. 9, no 4, p. 812–817.
13. Rees, W. 1992. « Ecological footprints and appropriated carrying capacity: What urban economics leaves out ». *Environment and Urbanisation*, (1992), p. 121–130.
14. Wackernagel, Mathis. 1994. « Ecological Footprint and Appropriated Carrying Capacity: A Tool for Planning Toward Sustainability ». PhD Thesis, School of Community and Regional Planning, The University of British Columbia, Vancouver, Canada.
15. Wiedmann, Thomas, Manfred Lenzen, Karen Turner and John Barrett. 2007. « Examining the global environmental impact of regional consumption activities — Part 1: A technical note on combining input–output and ecological footprint analysis ». *Ecological Economics*, vol. 62, no 1, p. 37–44.
16. Butchart, Stuart, Matt Walpole, Ben Collen and Arco van Strien. 2010. « Global Biodiversity: Indicators of Recent Declines ». *Sciences*, (2010).
17. Galli, Alessandro, Justin Kitzes and P Wermer. 2007. « An exploration of the mathematics behind the Ecological Footprint ». *International Journal of Ecodynamics*, (2007).
18. Jin, Wein, Linyu Xu and Zhifeng Yang. 2009. « Modeling a policy making framework for urban sustainability: Incorporating system dynamics into the Ecological Footprint ». *Ecological Economics*, (2009).
19. Holden, Erling. 2004. « Ecological footprints and sustainable urban form ». *Journal of Housing and the Built Environment*, vol. 19, no 1, p. 91–109.
20. Holden, E. 2012. « Ecological Footprint ». *Norway In International Encyclopedia of Housing and Home*, p. 6–11.
21. Statistics Canada. 2013. *Survey of Household Spending 2010-2013, Custom Tabulation*.
22. United Nations Statistics Division. 2015. « COICOP - United Nations Statistics Division ». <<http://unstats.un.org/unsd/cr/registry/regcst.asp?Cl=5>>. Consulté le 18 novembre 2015.
23. Calgary, City of and Global Footprint Network. 2007. *Understanding Calgary's Ecological Footprint*. Coll. « Toward a preferred future ».
24. Galli, Alessandro, Justin Kitzes and P Wermer. 2007. « An exploration of the mathematics behind the Ecological Footprint ». *International Journal of Ecodynamics*, (2007).
25. Rees, William and Lyse Walker. 1997. « Urban density and Ecological Footprint: An analysis of Canadian Households ». (1997).
26. Biesiot, Wouter and Jan Norman Klaas. 1999. « Energy Requirements of Household Consumption: A Case Study of The Netherlands ». *Ecological Economics*, (1999).
27. Transport Canada. 2013. *Transports in Canada 2013*.
28. Wackernagel, Mathis and William Rees. 1996. « Our Ecological Footprint: Reducing Human Impact on the Earth ». New Society Publishers.





## Expanding Boundaries: Systems Thinking for the Built Environment

### LIFE CYCLE ASSESSMENT AS A DESIGN AID TOOL FOR URBAN PROJECTS

C. Roux<sup>1\*</sup>, G. Herfray<sup>2</sup>, P. Schalbart<sup>1</sup>, B. Peuportier<sup>1</sup>

<sup>1</sup> MINES ParisTech, PSL – Research University, CES – Center of Energy Efficiency of Systems, 60 Bd St Michel, 75006 Paris, France

<sup>2</sup> Efficacy research institute – Champs-sur Marne, France

\*Corresponding author; e-mail: charlotte.roux@mines-paristech.fr

#### Abstract

Sustainability is now targeted in nearly all urban projects, but life cycle assessment (LCA) is generally seen as too complex, so that more qualitative approaches are preferred. Indeed, the importance of environmental problems regarding e.g. climate change, human health, biodiversity and resource depletion justifies a more precise decision making process.

A life cycle simulation tool has been developed to model urban projects including various buildings, streets, green and other public spaces, and networks (drinking water, waste water, district heating...). This tool, developed in an object oriented approach, associates dynamic building energy simulation and LCA, complemented with modules for open spaces and networks. A set of environmental indicators is evaluated, e.g. resource depletion, energy and water consumption, global warming, waste generation, toxicity. Several alternatives can be compared, constituting an urban design aid.

Continuous improvement of the tool has been performed since the 90's, expanding the boundaries from buildings to districts assessment. A dynamic model was recently introduced to take into account temporal variation of the electricity consumption in buildings and interaction with the electricity system. Results show the importance of this dynamic evaluation in the case of plus-energy buildings.

This multidisciplinary approach allows comprehensive assessment of districts, constituting a decision support in early phases of urban projects. The assessment of a project in the Greater Paris Area is presented to illustrate this integrated approach.

#### Keywords:

Life Cycle Assessment; Urban projects; Eco-design tool; dynamic simulation

## 1 INTRODUCTION

Beside stricter energy regulations, environmental consciousness is increasing in the building sector. Thermal simulation tools are now widely used to assist building designers in creating comfortable and energy-efficient buildings. In such low energy buildings, the environmental impacts of the use stages are reduced and other stages become important, particularly the fabrication of the building products. Life cycle assessment (LCA) tools have therefore been developed, according to the ISO 14040 standard. This allows low energy and plus energy buildings to be evaluated on a more comprehensive basis, accounting for the fabrication of materials and equipment like solar energy systems as well as

the energy consumed and possibly exported to the grid.

Building LCA tools have been expanded to the district scale allowing a more integrated approach to be developed.

In France in 2011 almost 60 % of the total electricity production was consumed in buildings [1]. 33 % of dwellings and 25 % of office buildings are heated by electricity [2] and more than 45 % of dwellings also use electricity to produce domestic hot water [2]. This consumption is highly time-dependent, with daily, weekly and seasonal variations. For instance, electric heating induces a seasonal peak demand in winter with a high dependency on temperature, which is

increasing every year [1]. Local production of electricity, such as photovoltaic panels on buildings roofs, also has a time-dependent production. However, standard LCA practice is based on an average annual electricity mix, neglecting this variation.

The first objective of this communication is to present the district assessment methodology through an illustrative case study. The second objective is to show how the use of a dynamic electricity mix could improve the accuracy of LCA of building and district through a focus on space heating system and the effect of photovoltaic system installation on the environmental performance of the project.

After an introduction on the overall methodology for LCA of buildings and districts, the model developed to calculate the hourly electricity mixes is exposed. The LCA methodology is then illustrated on a case study: a district development project in the Greater Paris Area. Finally we discuss limitations of the dynamic mix model and future possible developments.

## 2 MATERIALS AND METHODS

### 2.1 Buildings' LCA

Since the 1980's, several tools have been developed around the world. Thanks to research projects like REGENER [3], a common methodology basis was sketched out for buildings' LCA tools. Eight European tools were then compared in the frame of the thematic network PRESKO [4].

Impact indicator	Unit
Cumulative Energy Demand (CED)	GJ
Water consumption (W)	m <sup>3</sup>
Abiotic Depletion Potential (ADP)	kg Sb-eq
Non-radioactive waste creation (NRW)	t eq
Radioactive Waste Creation (RW)	dm <sup>3</sup>
Global Warming Potential (GWP)	t CO <sub>2</sub> -eq
Acidification Potential (AP)	kg SO <sub>2</sub> -eq
Eutrophication Potential (EP)	kg PO <sub>4</sub> <sup>3-</sup> -eq
Damage caused to ecosystems (BD)	PDF.m <sup>2</sup> .yr
Damage to human health (HD)	DALY
Photochemical Oxidant Formation (smog) (POP)	kg C <sub>2</sub> H <sub>4</sub> -eq
Odour (O)	Mm <sup>3</sup>

Table 1: Environmental indicators in EQUER

Linked to the dynamic building energy simulation (BES) tool COMFIE [5], the novaEQUER tool has been developed to model the life-cycle of buildings, from construction to dismantling, through utilisation and renovation stages [6,7]. It considers twelve indicators, mostly from the

CML2002 and Ecoindicator 99 methods to get a comprehensive set of environmental impacts (see Table 1). It also includes an extension to urban district evaluation [8].

### 2.2 Electricity system simulation model

Since 2012, the French electricity transmission system operator (RTE) provides hourly production values for 10 groups of electricity production technologies (listed in Table 2).

This data has been used to reconstruct hourly electricity mixes averaging climatic and economical hazards of real years. Both electricity demand and production have been modelled. The model developed uses the same meteorological data as used for the thermal simulation of buildings. It allows evaluating buildings and district projects and their interaction with the grid in a consistent way.

Electricity production is split between dispatchable and non-dispatchable production, as indicated in Table 2. The methodological process is briefly summarised in the paragraphs below.

#### Electricity demand

The electricity demand is the sum of the national electricity demand, electricity needed for pumped storage capacities and external electricity demand (exports).

The national electricity demand is based on hourly, daily and monthly coefficients and a linear relation with national average ambient temperature, as shown in eq (1) below.

$$C_{\text{nat}}(h_d, d_w, m, s, T_{\text{ext}}) = P_{\text{base}} \times W_1 \times W_2 \times W_3 + \text{ThE} \times \overline{\Delta T}(T_{\text{ext}}) \quad (1)$$

W1, W2 and W3 are modulation coefficients of the electricity demand depending on the hour of the day (W1), the day of the week (W2) and the month of the year (W3). The ThE coefficient represent the thermal sensitivity of the electricity consumption. Its average value for France is 2367 MW.°C<sup>-1</sup> for winter (when temperature is below 15 °C) and 500 MW.°C<sup>-1</sup> for summer (when temperature is above 18 °C). P<sub>base</sub> is a base power load. Its value is set at 46.5 GW after identification on French 2013 data.

Electricity exports are modelled using a two layer neural network calibrated on year 2013 and using as input the nuclear plant availability, the photovoltaic and wind production and the national electricity consumption.

Pumped storage facilities mainly consume electricity at the daily minimum of national electricity demand and on week-ends. Based on these main features, a model has been identified

on 2013 data (eq (2)). Moreover, the modelled pumped storage capacity can only consume electricity if the electricity demand is below the weekly average.

$$\begin{aligned} \text{STEP}_{\text{pump}}(h_1, j_3) = & A \\ & \times \left[ 1 \right. \\ & \left. - \tanh \left( -l(\text{Res}(h_1, j_3)) \right) \right. \\ & \left. - \text{Min}_{j_3} [\text{Res}(h_1, j_3)] \right) \right] \end{aligned} \quad (2)$$

$A$  is the availability of the power plant,  $\text{Min}_{j_3} [\text{Res}(h_1, j_3)]$  is the daily minimum of the residual national electricity demand. “ $l$ ” is a parameter calibrated on 2012 data. Its value is  $1.1\text{E-}4 \text{ MW}^{-1}$ .

#### *Nondispatchable production*

Nondispatchable production consists of various technologies that are not able to adjust their production when a change in demand occurs.

They can be driven by local economy or municipalities needs (gas and fuel CHP, biogas, biomass waste incineration facilities) or by meteorological parameters (run-of-river hydro, wind and PV).

Gas and fuel CHP, biogas, biomass and waste incineration hourly load factors were constructed using historical data from years 2012 and 2013. Run-of-river hydro hourly load factor was built based on daily minimum of total hydraulic production from year 2007 to 2013.

The Photovoltaic load factor was estimated from radiation data and the wind power load factor was estimated from wind speed given in the meteorological data from the French building thermal regulation (RT2012). Load factors were weighted according to the installed capacity in each climatic zone included in RT2012.

#### *Dispatchable production*

Dispatchable production was estimated using a bounded and constrained optimisation model minimising cost of electricity generation on a monthly horizon.

It takes into account ramp constraints and minimal and maximal load for each group of technologies. The parameters were identified in 2013.

Name	Share in annual average mix 2014 (%)	Description
<b>Nondispatchable</b>		
Run-of-river / small dams	8.2	Reservoir filling duration < 200 h
Combined Heat and power (CHP) Gas / Fuel	2.4	Decentralised production, not dispatchable
Wind	3.1	1-3 MW wind turbines
REN – Thermal	1.2	Municipal waste (58 %), Biomass (19 %), Biogas (19 %)
Photovoltaic (PV)	1.1	Open ground (37 %), on-roof multi-Si systems (43 %) and small on-roof mono-Si systems (20 %)
<b>Dispatchable</b>		
Nuclear	77.1	Pressurised Water Reactor
Large dams	3.2	Reservoir filling duration > 200 h
Coal & Gas	2.5	Centralised power plant from coal (70 %) and gas (30 %)
Pumped storage hydro	1.2	Electricity consumption of pumped storage excluded of the inventory
Peak / Imports / Others	<0.1	Fuel power plants, fuel and gas turbines Imports: Belgium (50 %), Germany (26 %), Spain (21 %), Switzerland (2 %) and Italy (1 %)

Table 2: List of Electricity production technologies in France

#### *Model validation*

The model was validated in 2014. The mean absolute percentage error (MAPE) for the total electricity demand is 3.8 %. The MAPE for nuclear production that represents around 77 % of the total electricity production in 2014 is less than 2 %. Correlation coefficients between modelled and measured data range from 0.7 (pumped storage) to 0.99 (nuclear). Only peak load technologies are not well represented but they account for less than 0.1 % of the total production in 2014.

The model was considered to be robust enough to give a representation of hourly variation of the electricity mix for a typical meteorological year.

#### **2.3 Case study description**

The studied project includes collective residential buildings (33 124 m<sup>2</sup>), offices (44758 m<sup>2</sup>) and shops (3829 m<sup>2</sup>) on a total land area of around 40 000 m<sup>2</sup> with an estimated 1060 inhabitants, 3715 office employees and 176 shop employees. 24 % of the total area will be composed of green

spaces. An overview of the site plan is given in fig.1.

Three buildings' envelope alternatives were assessed from this plan: a reference project following current French energy regulation (RT2012), a passive alternative (PAS) and a plus energy alternative (BEPOS). The BEPOS alternative is based on the PAS alternative, and integrates an on-roof photovoltaic system of 872 kWc. The main features of the two buildings' envelope alternatives are displayed in Table 3.

	RT2012	PAS-BEPOS	
<b>External wall</b>	Internal insulation	External insulation	
	Concrete (16cm)	Concrete (16cm)	
	Rockwool (20cm)	Rockwool (25 cm)	
<b>Ceiling insulation</b>	Rockwool (26cm)	Rockwool (26cm)	
<b>Floor</b>	Concrete (20cm)	Concrete (20cm)	
	Rockwool (16cm)	Rockwool (20cm)	
<b>Intermediary floor</b>	Concrete (20cm)	Concrete (20cm)	
<b>Glazing</b>	Double glazing	Double glazing	
<b>Ventilation</b>	Without heat recovery	With heat recovery (efficiency of 50 %)	of

Table 3: Main features of the envelope alternatives

The set point temperature for heating is 19°C when occupants are inside the buildings and 16°C otherwise. Dwellings do not have chilling systems. The set point for cooling in offices and shops is set at 26°C during opening hours (and 30°C otherwise). The average occupancy rate is 0.03 occ.m<sup>-2</sup> for dwellings, 0.08 occ.m<sup>-2</sup> for offices, and 0.14 occ.m<sup>-2</sup> for shops.

Shading devices and opening of windows (at night in dwellings, in both alternatives) were taken into account to evaluate the cooling rate and ensure occupants' comfort.

## 2.4 LCA hypotheses

The LCA of the whole project was performed for the two alternatives considering a 100 year lifespan, accounting for transport of districts users and domestic waste generation.

An average of a 100 km transport distance by truck was considered from the factories to the buildings' sites, 20 km from the buildings sites to incineration facilities and 2 km to landfill. The considered lifespans are 10 years for buildings' finishes, 30 years for windows and doors, 25 years for the photovoltaic system, and 100 years for the other elements and the buildings as a whole.

Environmental impact related to electricity consumption and production are evaluated at each hour of the typical meteorological year, following the methodology exposed in [9].

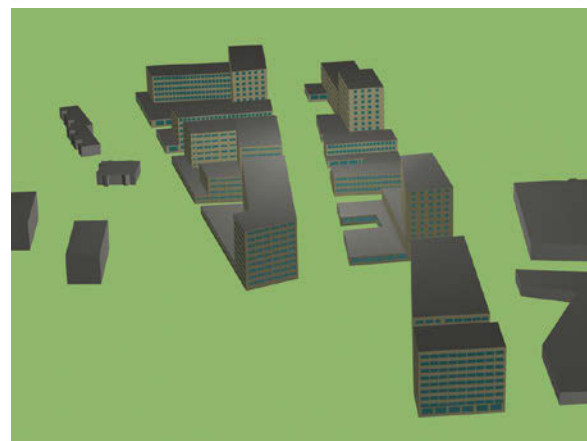

Figure 1: Overview of the district project

## 3 RESULTS

### 3.1 BES results

BES results are presented in Table 4. The heating load is relatively low in both alternatives due to high internal gains in offices.

Average results hide important disparities between the different buildings and thermal zones. For instance, considering the RT2012 alternative, heating load varies from 31 (north oriented dwellings) to 3 kWh.m<sup>-2</sup>.yr<sup>-1</sup> (south oriented offices) and cooling load from 1 to 7 kWh.m<sup>-2</sup>.yr<sup>-1</sup>.

In kWh/m <sup>2</sup> /yr	RT2012	PAS-BEPOS
<b>Heating load</b>	11	2
<b>Cooling load</b>	3	4
<b>Hot water</b>	7.2	7.2

<b>Specific electricity</b>	19.7	19.7
<b>Fans consumption (Ventilation)</b>	1.8	3.4

Table 4: BES results

### 3.2 LCA results

#### Contribution analysis

Results comparing the RT2012, the PAS and the BEPOS alternatives for cumulative energy demand, global warming potential and radioactive waste generation are presented in Fig.2. The considered heating system was electric heating, a system still popular in France.

Transport and domestic waste are important contributors. For the RT2012 alternative, they represent more than 40 % of GWP for instance.

Electricity consumption (specific electricity, space cooling, space heating, water heating, and ventilation) is also a major contributor, representing 36 % of GWP and more than 80 % of CED and Rad.Waste.

The BEPOS alternative is seen as the most favourable one: its GWP impact is similar to the PAS alternative but CED and Rad.Waste indicators are respectively 14 % and 16 % lower, due to avoided electricity production from the grid thanks to the PV system.

#### Transport, waste and public spaces

Occupants' daily travel, domestic waste and public spaces are other neighbourhood contributors. Together they have a large contribution to the total impacts: more than 50 % of GWP, 19 % of CED and 20 % of radioactive waste generation. At the district scale, actions can be taken that affect transport (bike lanes, multimodal facilities, number of parking spots) or domestic wastes practices (collective composting, recyclable bottle collection...). They have to be included in the evaluation when studying a district level project.

#### Dynamic vs static electricity mix

The use of the static electricity mix generates errors regarding the impact of electricity consumption. For this project, avoided GWP due to the photovoltaic system electricity production is overestimated by 13 % when using an annual average mix instead of an hourly mix (Fig. 3). On the contrary, electrical heating impact is underestimated by more than 20 % for the RT2012 and the PAS alternative (see Fig.3).

Electric space heating contributes to 8 % of GWP, 16 % of CED and 15 % of Rad.Waste considering the RT2012 alternative (see Fig.2). It is still an important area of improvement that should not be underestimated.

Moreover, the use of an hourly mix allows evaluating peak shifting strategies. The global warming potential per kWh for electrical heating varies from 50 to 200 gCO<sub>2</sub>eq. Control

strategies, particularly efficient in well-insulated buildings [10], could be implemented. They can be more precisely evaluated with the suggested model than using an annual average electricity mix.

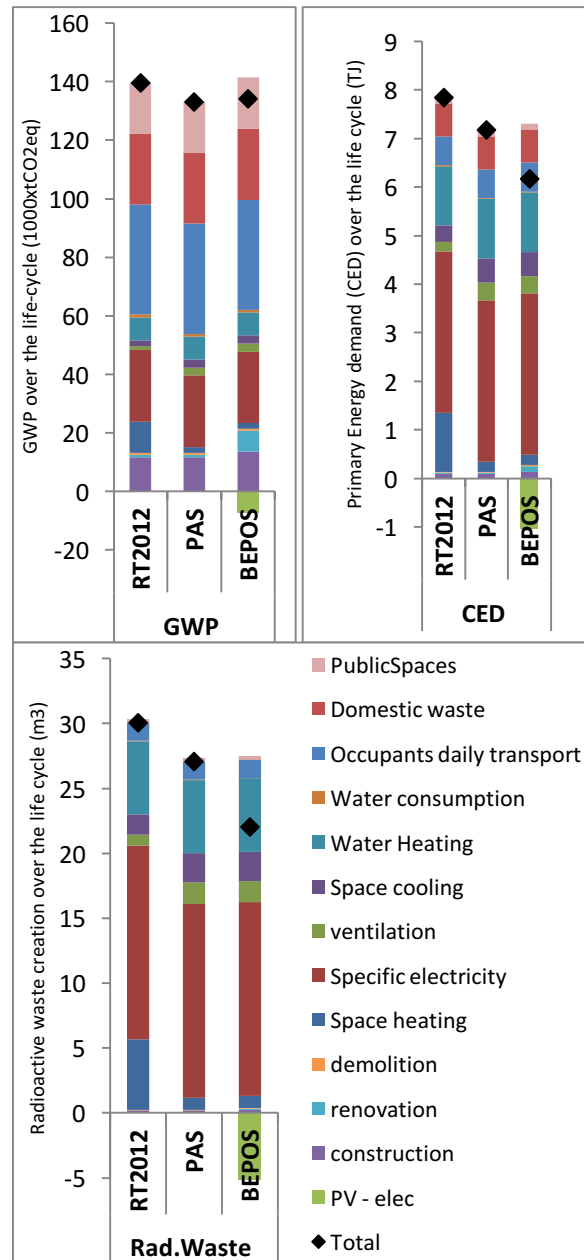

Figure 2: LCA results for the three alternatives

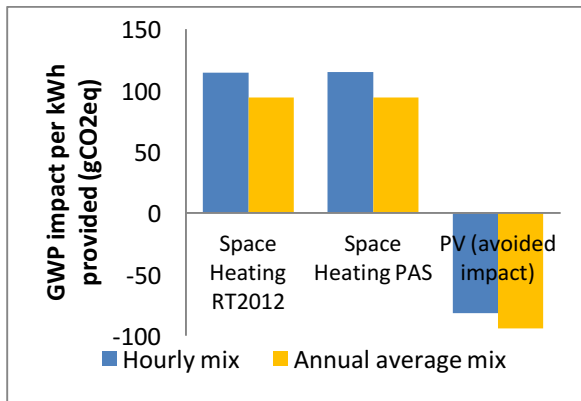

Figure 3: GWP impact of electric space heating and avoided impact of photovoltaic production using an hourly or an annual average mix.

#### 4 DISCUSSION AND CONCLUSION

LCA tools are now available and operational to assess the environmental performance of an urban project at the district level [11].

Domestic waste treatment, occupant daily transport and public spaces have to be integrated as they can be influenced by district design and are important contributors (e.g. more than 50 % of GWP).

New developments of the novaEQUER tool regarding the hourly variation of the electricity mix allows evaluating more precisely smart and plus-energy buildings.

Current research perspectives are investigation of prospective and consequential aspects. Environmental evaluation of alternatives of a future project is meant to provide help for project designers in their decision making process. Therefore a consequential approach [12,13] using system expansion allocation and marginal suppliers for electricity and materials could be studied. Buildings and infrastructure are long lasting, e.g. 100 years or more. The electricity mix will probably change during such a life span, as shown in the prospective studies conducted by the French transmission system operator [1].

#### 5 ACKNOWLEDGMENTS

This work has been realised thanks to the funding of the research chair of Ecodesign of infrastructure with the participation of the research institute Efficacy.

#### 6 REFERENCES

1. RTE, Bilan prévisionnel 2012 de l'équilibre offre-demande: la sécurité de l'alimentation électrique assurée jusqu'en 2015, (2012). (accessed November 26, 2012).

2. ADEME, Chiffres clés du bâtiment, ADEME 2011, (2011). (accessed November 26, 2012).

3. B. Peuportier, K. Kohler, C. Boonstra, European project REGENER, life cycle analysis of buildings., In: 2nd International Conference "Buildings and the Environment", Paris France (1997).

4. B. Peuportier, D. Kellenberger, D. Anink, H. Mötzl, J. Anderson, S. Vares, et al., Inter-comparison and benchmarking of LCA-based environmental assessment and design tools, in Sustainable Building 2004, Varsovie.

5. B. Peuportier, I. Sommereux Blanc, Simulation Tool with Its Expert Interface for the Thermal Design of Multizone Buildings, International Journal of Solar Energy. 8 (1990) 109–120.

6. B. Polster, B. Peuportier, I. Blanc Sommereux, P. Diaz Pedregal, C. Gobin, E. Durand, Evaluation of the environmental quality of buildings towards a more environmentally conscious design, Solar Energy. 57 (1996) 219–230.

7. Peuportier, S. Thiers, A. Guiavarch, Eco-design of buildings using thermal simulation and life cycle assessment, Journal of Cleaner Production. 39 (2013) 73–78.

8. E. Popovici, PHD thesis, "Contribution to the life cycle assessment of settlements," 2005.

9. C. Roux, P. Schalbart, B. Peuportier, Accounting for temporal variation of electricity production and consumption in the LCA of an energy-efficient house, Journal of Cleaner Production. Accepted manuscript, in press (2015)

10. B. Favre, B. Peuportier, Application of dynamic programming to study load shifting in buildings, Energy and Buildings. 82 (2014) 57–64.

11. M. Lotteau, P. Loubet, M. Pousse, E. Dufrasnes, G. Sonnemann, Critical review of life cycle assessment (LCA) for the built environment at the neighborhood scale, Building and Environment. (2015).

12. T. Ekvall, B. Weidema, System boundaries and input data in consequential life cycle inventory analysis, The International Journal of Life Cycle Assessment. 9 (2004) 161–171.

13. B.A. Sandén, M. Karlström, Positive and negative feedback in consequential life-cycle assessment, Journal of Cleaner Production. 15 (2007) 1469–1481.



## Expanding Boundaries: Systems Thinking for the Built Environment

### FROM A SIMPLE TOOL FOR ENERGY EFFICIENT DESIGN IN THE EARLY DESIGN PHASE TO DYNAMIC SIMULATIONS IN A LATER DESIGN STAGE

A. Miyamoto<sup>1</sup>, D. Trigaux<sup>1</sup>, T. Nguyen Van<sup>1</sup>, K. Allacker<sup>1</sup>, F. De Troyer<sup>1</sup>

<sup>1</sup> KU Leuven, Faculty of Engineering Science - Department of Architecture - Division of Architectural Engineering, Kasteelpark Arenberg 1 - box 2431, 3001 Leuven, Belgium

\*Corresponding author; e-mail: ayu.miyamoto@kuleuven.be

#### Abstract

In the past decade, many tools have been developed to support design decisions related to energy efficient buildings. However, these energy simulation tools are complex and require too detailed input data to be appropriate for use in the sketch design stage. Architects and designers hence often take energy related design decisions based on their own experiences or intuition. This paper proposes a simple tool to estimate the energy consumption in the sketch design stage which can, in a later design stage, be linked to a dynamic simulation tool. Furthermore, this study proposes the use of visualisation methods by architects to improve the integration of energy simulations in the sketch design stage. The proposed simple energy estimation tool is based on the "dynamic Equivalent Heating Degree Day Method (dynamic EHDD)". Relevant sketch design parameters identified are thermal compactness, insulation level, effective use of direct and indirect solar gains, internal gains including occupant presence and activities, and ventilation strategies. In order to develop in-depth simulations, the tool is linked to the dynamic energy simulation software "EnergyPlus" to be used during the detailed design stage. The tool is developed for the Belgian context, but the approach is also valid for other contexts.

**Keywords:** design supporting tool; design process; dynamic EHDD; user behaviour; solar gains; internal heat gains; energy simulation

#### 1 INTRODUCTION

The 2010 Energy Performance of Buildings Directive (EPBD) requires EU member states to improve energy efficiency in new buildings for achieving the target of Nearly Zero Energy Buildings (NZEBS) by 2020 [1]. In order to reach this target, architects should integrate energy efficiency in their design process from the early design phase on, especially in small scale projects with a lack of engineers' support due to financial and time constraints.

The use of Building Performance Simulation (BPS) tools during the design process is effective to support decisions for energy efficient buildings. However, most existing BPS tools are not suitable in the early design phase [2]. Tools which generate rough energy estimations in the sketch design stage and which are later on linked to more accurate calculations in the detailed design stage, are required to stimulate the exchange of ideas and solutions between clients, architects and

engineers [3][4]. In addition, the performance of buildings depends not only on architectural design solutions but also deeply on user behaviour [5]. The well-known gap between predicted and actual performance in energy efficient buildings is partially caused by the lack of consideration for user patterns during the design process [6]. It is therefore essential to consider the influence of both architectural design decisions and user behaviour on the energy performance, from an early design phase onward. This paper proposes a decision support tool including these two perspectives. Section 2 presents the methodology related to the dynamic Equivalent Heating Degree Days (dynamic EHDD) and solar gain calculation. The use of the tool during the different design stages is described in section 3. Section 4 focuses on the tool structure. Conclusions are formulated in the final section.

## 2 METHOD

### 2.1 Dynamic Equivalent Heating Degree Day (dynamic EHDD) method

The dynamic EHDD is a refinement of the Equivalent Heating Degree Day method (EHDD), which is a simplified calculation method for predicting the heating energy demand in buildings, taking into account the internal and solar “free” heat gains [4].

Compared to the existing EHDD method [7], the dynamic EHDD includes more accurate calculations of internal gains from occupants and appliances and solar gain calculations based on semi-dynamic simulations [8]. The number of EHDD is estimated for each month of the heating season based on two temperature curves (Fig.1): the temperature of no more heating ( $T_{NH}$ ) and the temperature without heating ( $T_{WH}$ ). The first temperature line ( $T_{NH}$ ) is defined as the indoor temperature above which no heating is required, as the internal gains will be sufficient to compensate the heat losses.  $T_{NH}$  is calculated, considering the impact of the temperature set point ( $\Delta T_{set}$ ) and internal gains from appliances ( $\Delta T_{app}$ ) and occupants ( $\Delta T_{per}$ ). The second temperature line ( $T_{WH}$ ) is the increased indoor temperature, resulting from solar gains ( $\Delta T_{sun}$ ), when the building is not heated and not occupied. The line of the outdoor temperature ( $T_e$ ) is obtained via linear regression of monthly temperature reported in the Test Reference Year [9]. In Fig.1 the number of dynamic EHDDs is represented by the blue area.

The dynamic EHDD method is fast and accurate enough to predict the heating demand. Moreover, this method is particularly appropriate for the early design phase because of the limited number of required input data. A more detailed description of the dynamic EHDD can be found in [4].

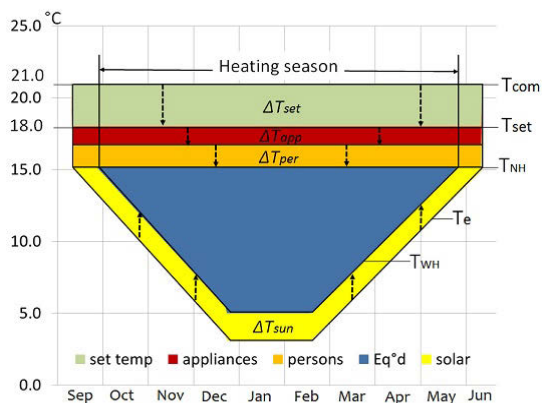

Fig. 1: Representation of dynamic EHDD for the temperate climate in Belgium.

### 2.2 Solar gain calculation

In the proposed tool, solar gains are calculated based on the semi-dynamic method defined in the Flemish Energy Performance of Buildings (EPB) regulation [10]. In this method solar gains are calculated as the sum of the direct, diffuse and reflected solar gains. The impact of shading patterns is approximated by defining a set of obstructions and overhang angles for each window [11]. In the proposed tool, as the obstructions in the surrounding environment are defined as cylinder obstructions, those vertical angles are calculated based on the average of the horizontal obstructions in a range of  $90^\circ$  around the centre of each window. More details concerning the EPB method for solar gain calculations can be found in [11].

## 3 DESIGN PROCESS

Based on the RIBA Plan of Work 2013 [12], the early design process can be divided into three stages (Fig.2): (1) Preparation and Brief, (2) Concept Design and (3) Developed Design. In this research, the early design stages are further subdivided into three sub-stages: (a) Pre-Design stage, (b) Sketch design stage and (c) Preliminary design stage. In the proposed tool, specific input sheets are developed for each sub-stage: Brief-Form0, Form1 and Form2. Input parameters are classified into three categories: geometry, technical choices and user behaviour. In the more advanced design stages, more detailed input parameters are required in each category. The following subsections describe the different sub-stages of the early design process.

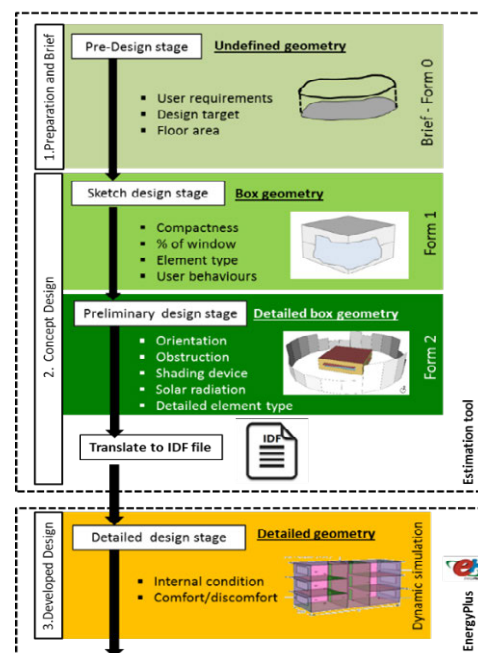

Fig. 2: Design process and design stages.





Fig. 3: Input parameters and graphical representation of obstructions in Form2.

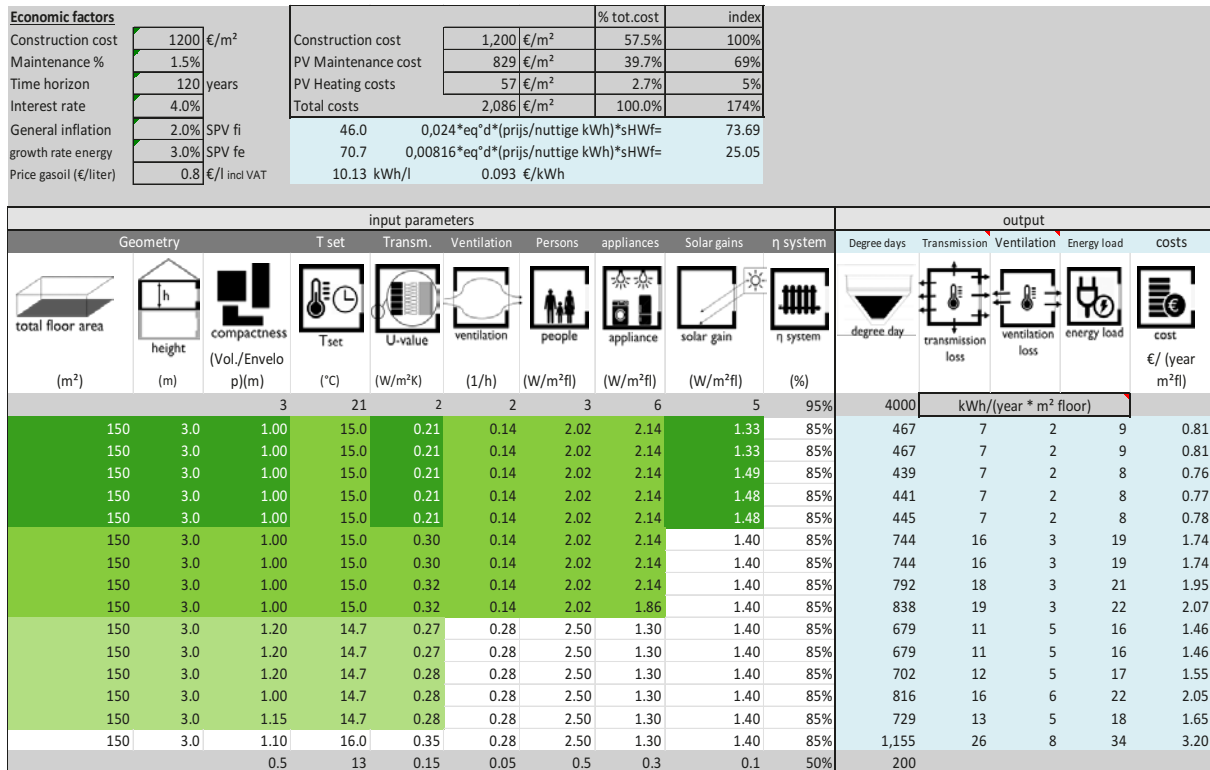

Fig. 4: All design combinations in the "Dashboard".

Area		150 m <sup>2</sup>														
People		4 persons														
	Refrigerating appliances			Washing machine				energy by evaporation	Dishwasher	Cooking hobs	Light	Electronic	Household equipment	auxiliary Power	Total	
	Fridge	Freezer	Combination	washing process	spin dry process	tumble dryer	installed									installed
Installation	installed	installed	not installed	installed	installed	installed	in heated area	heated area	heated area	heated area						
Location	heated area	heated area	heated area	heated area	heated area	heated area	in heated area	heated area	heated area	heated area						
Type	-	-	-	-	-	-	Vented			Traditional						
Class	A+	A+	A++	A	D	B		A++	-	-						
kwh/cycle				0.96	1.0184	2.77	3.13	0.9	0.25	-		50	2.16			
spin speed (rpm)	-	-	-	-	1000 to 1100 rpm	-	-	-	-	-	-	-	-	-	-	
residual moisture per rmd	-	-	-	-	60%	-	-	-	-	-	-	-	-	-	-	
correction for energy consumpti	-	-	-	-	0.875	-	-	-	-	-	-	-	-	-	-	
kwh/cycle(corrected)	-	-	-	-	0.8911	-	-	-	-	-	-	-	-	-	-	
kg	-	-	-	5	5	5	-	-	-	-	-	-	-	-	-	
W											50	80				
number of light											5					
% of CFLs											80%					
hour/person/day											3				24	
cycle/hours for cooking/person/week	-	-	-	1	1	1	1	4	7	-	-	-	-	-	7	
h/person/year				52.14	52.14	52.14	52.14	208.57	365.00	1095	550	200.00	788.40	8760		
kwh/year	130.00	346.00	0.00	200.23	111.51	576.76	652.83	750.86	365.00	1095.00	176.00	200.00	788.40	3575.36	kwh/year	
% heat gain	100%	100%	100%	30%	30%	80%	-100%	30%	50%	100%	100%	100%	50%	234.80	W	
internal gain (W)	14.84	39.50	0.00	6.86	3.82	52.67	-74.52	25.71	20.83	125.00	20.09	22.83	45.00	1.57	W/m <sup>2</sup>	
% energy consumption	4%	10%	0%	6%	3%	16%		21%	10%	31%	5%	6%	22%			
% internal gain	6%	17%	0%	3%	2%	22%	-32%	11%	9%	53%	9%	10%	19%			

Fig. 5: The input and output parameters in the "Appliances" support sheet.

### 3.1 Pre-design stage: Brief-Form0

The pre-design stage is an important stage for all stakeholders as it includes the definition of the design target and the setting of global technical aspirations [13]. This stage is implemented in the input sheet "Brief-Form0". This sheet includes the several architectural and economic factors. Input parameters related to the geometry include the floor area, floor height and a global estimation of the building compactness. For the technical choices a global thermal insulation level and a ventilation strategy are considered. Concerning the user behaviour, a daily average set point temperature over 24 hours and all spaces is defined. For the definition of the design target, without carrying out detailed calculations, and detailed knowledges, references are included in Brief-Form0.

### 3.2 Sketch design stage: Form1

In the sketch design stage, important decisions are made influencing the scheme of the project and future decisions. Important parameters are the building geometry and layout. In Form1, the building layout is defined as a box geometry with a global window ratio. The building compactness is calculated based on the box geometry. Concerning the technical choices, standard element types are selected based on the database of building elements from the MMG research project ("Environmental profile of building elements") [14]. Input parameters include the insulation material and thickness and window materials. Based on the selected insulation characteristics and global window ratio, the average building U value can be calculated. Regarding the user behaviour, more detailed temperature set points are defined and internal gains by appliances and occupants are estimated.

### 3.3 Preliminary design stage: Form2

More detailed design decisions are made in the preliminary design stage preparing the later phase [13]. Concerning the building geometry, the impact on solar gains of shading devices and obstructions from the environment is calculated. For the technical choices specific insulation materials are selected for each element of the building envelope. Per orientation, the glazing type and frame type are selected for each window (Fig.3). Regarding the user behaviour, detailed internal heat gains are calculated (Fig.5).

### 3.4 Translation to an Input Definition File (IDF) for dynamic energy simulations

A macro is developed to translate the input parameters from the estimation tool to an Input Definition File (IDF file) that can be used for dynamic energy simulations with the software EnergyPlus [15]. This macro provides a link between the design language of the architects, used in the estimation tool and the numeric language of the engineers, used in an IDF-file [16]. This approach reduces the gap between the architects and engineers and between the early and later design phases.

## 4 TOOL DESCRIPTION

### 4.1 "Dashboard" to navigate in the design space

A simple spreadsheet interface, called the "Dashboard", is implemented to define different design options. For each design option, the annual heating energy demand is calculated as the sum of the heat losses by transmission and ventilation, based on the dynamic EHDD [4]. As during the early design phase the possibility to compare alternatives is more important than an absolute value [17], all design options that are defined in different design stages (Form 0, 1 and 2) are

reported in the core line of the “Dashboard” (Fig.4). Below that line the design history remains visible and is also visualized in a graph, using parallel coordinates (Fig.6). The graph can speed up the analysis of the design space and improve the integration of energy simulations in the early design phase. In this graph, all input variables leading to one output result are connected via a line. The exploration of the “design space” is hence investigated in the “Dashboard”. Supporting sheets are used to generate input (via macros) for the “Dashboard”. Different colours explain the origin of the values from different design stages: light green is from Brief-Form0, green is from Form1 and dark green is from Form2. For each input parameter, average values (in white) and minimum and maximum values (in grey) are defined as a starting case for the Belgian context.

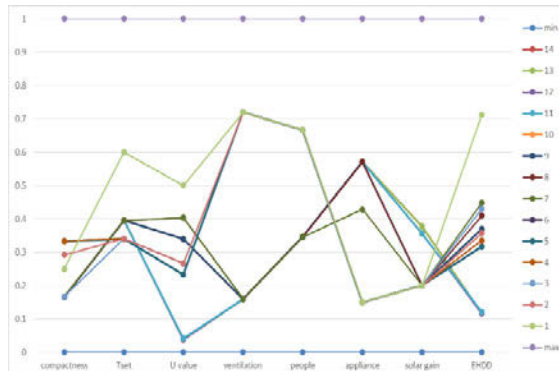

Fig. 6: Graphical representation of all design combinations, using parallel coordinates.

#### 4.2 User behaviour

As the energy consumption is strongly related to the user behaviour, considering user requirements from the early design phase can effectively increase the energy efficiency in buildings.

Parameters related to the user behaviour are divided into four categories: (1) Temperature setpoint (2) Human activity (3) Usage of appliances (4) Ventilation strategy.

Firstly, the temperature setpoint ( $T_{set}$ ) is calculated based on the heating setpoint schedule over 24 hours and over all the building zones in the building. In the  $T_{set}$  sheet, setting the schedule of  $T_{set}$  and ratio of the heating zone provides an average daily  $T_{set}$ . Weekly and seasonally  $T_{set}$  are calculated based on a daily  $T_{set}$ .

Secondly, internal heat gains resulting from human activities are estimated. Due to the metabolic activity, human bodies lose heat into the surrounding environment. Based on the metabolic rates for different states of activity, defined in ASHRAE Fundamentals [18] and using an activity schedule over 24 hours, the average internal gains from occupants can be calculated.

Thirdly, electrical energy used by appliances in a household is partly released as heat. The internal heat gains from appliances are based on power data from technical specifications. The heat output rate is calculated based on the calculation method defined in the Passive House Planning Package (PHPP) [19]. Input parameters are the location in the building, the equipment class according to the EU energy label and the user pattern (Fig.5). Furthermore, this step introduces architects and occupants to the impact of varying the equipment type and the user pattern on energy consumptions by appliances. Fourthly, the ventilation strategy is based on the Belgian standard “Ventilation facilities in residential buildings” (NBN D 50-001) [20]. An input parameter is the efficiency of the ventilation system.

#### 4.3 Obstructions

The use of passive solar gains in buildings is a critical issue in cold and moderate climates. Optimizing solar gains from the early design phase is an effective way to improve the energy efficiency in buildings. In this research, obstructions in the surrounding environment are modelled as cylinder obstructions composed of segments with different height in order to model any environmental conditions. The cylinder is divided into 24 parts ( $15^\circ$ ) and angles are defined based on the obstruction distance and height for different orientations (Fig.3).

## 5 CONCLUSIONS

In this paper a design tool is developed to support architects making decisions for energy efficient buildings and to link their decisions in the early design phase to those in the later detailed design phase. The strength of this tool is its capacity to generate fast and comparative energy estimations during different design stages, including the consideration of occupant behaviour. Consequently, the proposed tool facilitates the architect’s work in designing energy efficient buildings and improves the communication with other stakeholders during the design process. Moreover, this research can be applied to other contexts by using other climatic data as input for the dynamic EHDD method.

Concerning further research, the validation and usability of the design tool will be tested based on case studies. The tool is developed in cooperation with some architecture tutors and students. The usability test will be carried out by students. A workshop for architects will be organised to obtain feedback from practitioners. Furthermore the tool will be extended to evaluate summer comfort/discomfort.

## 6 REFERENCES

1. EPBD recast. DIRECTIVE 2010/31/EU OF THE EUROPEAN PARLIAMENT AND OF THE COUNCIL of 19 May 2010 on the energy performance of buildings (recast). *Official Journal of the European Union* 2010: 13–25.
2. Weytjens L, Attia S, Verbeeck G, Herde AD. The “Architect-friendliness” Of Six Building Performance Simulation Tools: A Comparative Study. *International Journal of Sustainable Building Technology and Urban Development* 2011; **2**(3): 237–244. DOI: 10.5390/SUSB.2011.2.3.237.
3. Attia S, Hensen JLM, Beltrán L, Herde AD. Selection criteria for building performance simulation tools: contrasting architects’ and engineers’ needs. *Journal of Building Performance Simulation* 2012; **5**(3): 155–169. DOI: 10.1080/19401493.2010.549573.
4. Miyamoto A, Nguyen Van T, Trigaux D, Allacker K, De Troyer F. Visualisation tool to estimate the effect of design parameters on the heating energy demand in the early design phases., *31th PLEA 2015*. Bologna: Ass. Building Green Futures; 2015. DOI: 10.13140/RG.2.1.1515.2085.
5. Lockton D, Harrison D, Stanton N. Making the user more efficient: design for sustainable behaviour. *International Journal of Sustainable Engineering* 2008; **1**(1): 3–8. DOI: 10.1080/19397030802131068.
6. Hauge ÅL, Thomsen J, Berker T. User evaluations of energy efficient buildings: Literature review and further research. *Advances in Building Energy Research* 2011; **5**(1): 109–127. DOI: 10.1080/17512549.2011.582350.
7. Diensten voor de programmatie van het wetenschapsbeleid. *Ontwerp en thermische uitrusting van gebouwen - deel 2*. Brussels: 1984.
8. Trigaux D, Oosterbosch B, Allacker K, De Troyer F. A design tool to optimize solar gains and energy use in neighbourhoods, *31th PLEA 2015*. Bologna: Ass. Building Green Futures; 2015.
9. *Test Reference Year weather data*.
10. Flemish Government. Besluit van de Vlaamse Regering van 11 maart 2005 tot vaststelling van de eisen op het vlak van de energieprestaties en het binnenklimaat van gebouwen - bijlage I 2005.
11. Trigaux D, Allacker K, De Troyer F. A simplified Approach to integrate Energy Calculations in the Life Cycle Assessment of Neighbourhoods, *30th International PLEA Conference*. Ahmedabad: 2014.
12. RIBA. RIBA Plan of Work 2013. <http://www.ribaplanofwork.com/Default.aspx> [accessed January 5, 2016].
13. Hemsath TL. Conceptual energy modeling for architecture, planning and design; impact of using building performance simulation in early design stages. *13th Conference of International Building Performance Simulation Association, Chambéry, France, August 26-28*.
14. Allacker K, Debacker W, Delem L, De Nocker L, De Troyer F, Janssen A, et al. *Environmental profile of building elements*. Mechelen: Danny Wille, OVAM; 2013.
15. U.S. Department of Energy. (n.d.). EnergyPlus Energy Simulation Software. <https://energyplus.net/>.
16. Gänshirt C. *Tools for ideas: an introduction to architectural design*. Basel Birkhäuser; 2007.
17. Attia S, Gratia E, De Herde A, Hensen JLM. Simulation-based decision support tool for early stages of zero-energy building design. *Energy and Buildings* 2012; **49**: 2–15. DOI: 10.1016/j.enbuild.2012.01.028.
18. ASHRAE Standing Standard Project Committee. *ASHRAE Standard Thermal Environmental Conditions for Human Occupancy*. Atlanta: ASHRAE; 2008.
19. Passive House Institute. *Passive House Planning Package (PHPP)*. Germany: Passive House Institute; .
20. Bureau de Normalisation. *NBN D 50-001 Ventilation facilities in residential buildings*. Brussels: 1991.



## Expanding Boundaries: Systems Thinking for the Built Environment

### ANALYSIS OF THE MATERIAL-RELATED DESIGN DECISION PROCESS IN FLEMISH ARCHITECTURAL PRACTICE

E. Meex<sup>1\*</sup>, E. Knapen<sup>1</sup>, G. Verbeeck<sup>1</sup>

<sup>1</sup> Hasselt University, Agoralaan Building E, 3590 Diepenbeek, Belgium

\*Corresponding author; e-mail: [elke.meex@uhasselt.be](mailto:elke.meex@uhasselt.be)

#### Abstract

Architects are the key actors in the building design process and as such responsible for many important design decisions, of which a large share influences the final sustainability level of the building. Up to now, little attention has been paid to their handling of (sustainable) material use, since no related regulation exists yet (in contrast to energy performance regulations). Some countries like the Netherlands are preparing for future legal requirements on the environmental impact of buildings, by imposing a mandatory calculation of the environmental impact of new buildings. Also the Flemish/Belgian authorities are developing a tool to incorporate environmental impact calculations in the building design process.

In anticipation of these upcoming legal requirements for sustainable material use, the design process of 14 real life design projects has been unravelled with a specific focus on the material choices during the design process. A process scheme of the material choices along the different design phases has been developed. Semi structured interviews with the architects gave input to fine tune the process scheme. This paper presents the lessons learned from this analysis in view of tool development for and feedback on the environmental performance of building design directed to the architect.

#### Keywords:

Case studies; Material selection; Architectural design; Building environmental impact

## 1 INTRODUCTION

Architects are key actors in building design, from concept to elaborated design, especially in Flanders (Belgium), where private client hood for individual dwelling construction or refurbishment is common practice and in most cases, involvement of an architect is required [1]. Consequently, many important design decisions by architects strongly influence the final sustainability level of the building design.

For now, (Flemish) architects still mainly relate sustainability to a good energy performance, due to the coming into force of the Energy Performance of Buildings Directive (EPBD) since 2006 [2] and its recast in 2010 aiming for nearly zero energy buildings by 2021 [3]. However, according to the Europe 2020 Initiative, Flagship 4 "Roadmap to a Resource Efficient Europe" [4], the material efficiency of building constructions will be tackled in the future by application of a

lifecycle approach assessment on buildings and materials.

The way (Flemish) architects deal with EPBD requirements in the design process was already investigated by Weytjens and Verbeeck [5]. However, up until now, little is known about the way architects handle material selection whilst designing, especially not with regard to sustainable material selection since no legal requirements are imposed yet. Some countries are already anticipating future (legal) targets on the environmental impact of buildings, e.g. the Netherlands, where a mandatory calculation of the environmental impact of new buildings and the materials used in these buildings is imposed (for now without a benchmark to comply with) [6]. However, it is still to be awaited if and how this calculation will influence architectural practice.

In Belgium, the regional governments are undertaking similar initiatives for the development

of a tool to calculate the environmental impact of building design projects (without the date for implementation set yet) [7]. In order to be able to develop an environmental impact assessment tool that is architect oriented and design supportive, the role and approach of the architect in material selection during the design process is investigated. Specifically, the timing of material decisions in the design process and the level of specification of these decisions (by the architect) are studied by means of a retrospective case study analysis. This will serve as input to define the most crucial points in the design process on which usable and appropriate feedback on the environmental impact should and could be provided to the architect.

Section 2 presents the research methods used. In section 3 an overview of the architect's profile and project characteristics is given, followed by a presentation of material decisions during the design process per design phase. Section 4 discusses these findings in the perspective of future tool development and in section 5, conclusions and further research steps are described.

## 2 METHODS

To investigate the architectural design process, with regard to the material selection process, the design information of 14 Flemish architectural design processes has been unravelled in a retrospective case study analysis.

By January 2015, nine architects provided design documentation of 14 new construction dwellings (constructed between 2009 and 2013). The sample consists of six semidetached and eight detached dwellings. Ten are traditional cavity wall constructions and four are timber frame construction.

A process mapping method was used for the analysis of the design documentation in order to identify moments for material decisions and levels of specification of these decisions [8-10].

For the process mapping of the design process, the design documentation was first structured into the four most prevalent phases of the design and construction process in Flanders: i) pre-design, ii) design phase with conceptual design, preliminary design and detailed design, iii) building permit phase and iv) execution phase, consisting of a tendering and construction phase. The post construction phase is not taken into account in this research.

Since material-related decisions are made on a more detailed level than the level of the building shape, this shape has been subdivided into six building layers in line with the research by Brand [11] (Fig. 1): i) building structure (load bearing function), ii) building skin (visible, exterior), iii) building shell (mostly thermal function, but also

waterproofing and/or airtightness), iv) building systems (technical equipment), v) interior space (finishing materials) and vi) room separations (interior walls). Brand [11] focused on the differences in life span of the layers, whereas here this subdivision will be used to present differences in timing and level of specification of material decisions for the different layers.

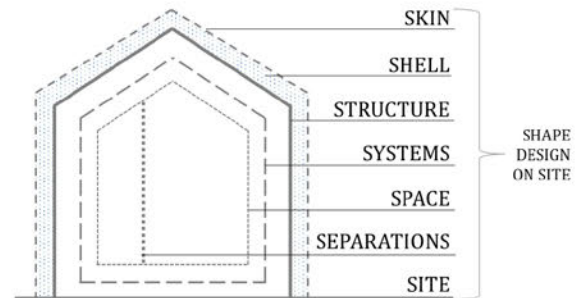

Fig. 1: Representation of the building layers considered in this research, based on [11].

In addition, also the degree of specification of material decisions is considered. Three levels of specification are used: i) level of material category, consisting of very general information e.g. brick or wood for the façade, ii) level of product type, containing more specific product characteristics such as thickness, colour, texture, heat resistance, etc. and iii) level at which a specific brand or producer of the material/product is chosen.

Finally, findings from the design documentation were crosschecked with the nine architects in semi structured interviews, with questions on their general design approach and their material selection strategy. Due to the small number of cases, the analysis cannot be considered representative for the entire building sector, but can nevertheless give insights into the material related design decision process of the Flemish architects.

## 3 RESULTS

Fig. 2 presents the most prominent findings from the analysis regarding the moments for material decisions and their level of specification in the design process. Decisions are qualitatively structured per design phase and subdivided per building layer (according to Fig. 1) and per level of specification. A thickening of the arrow indicates that the gross of the architects is concerned with that level of decision making at that moment, a dotted arrow indicates that only few architects are. The building layer's "structure" and "separations" are considered together here, as most architects (8/9) use similar materials for outer building structure and interior separation walls.

### 3.1 Predesign phase

As can be seen in Fig. 2, the main focus during the predesign phase is to align the preferences, targets and work methods of architect and client and to check the budget and regulation limitations. Most material decisions are not yet addressed in detail. The choice of construction type (structure and separations in Fig. 2) is discussed for the first time. For other building layers (skin, shell, systems and space in Fig. 2), clients may already express some preferences in the design brief (e.g. façade material), but these materials are not fixed yet in this phase.

### 3.2 Design phase

In the design phase, specifications to a material and/or product type level become available for all

building layers. Especially the carcass materials (structure and separations, skin and shell in Fig. 2) are specified to a product type level by the end of the design phase. At this point, all known material information such as types, sizes and quantities are implemented in an intermediate cost estimate. In some cases, even a brand name (e.g. for insulation) is provided, mostly based on the architect's previous experience with these materials. For building systems and interior finishing materials (systems and space in Fig. 2), detailed specifications are not available yet. Only general assumptions are taken into account in the design and the cost estimate.

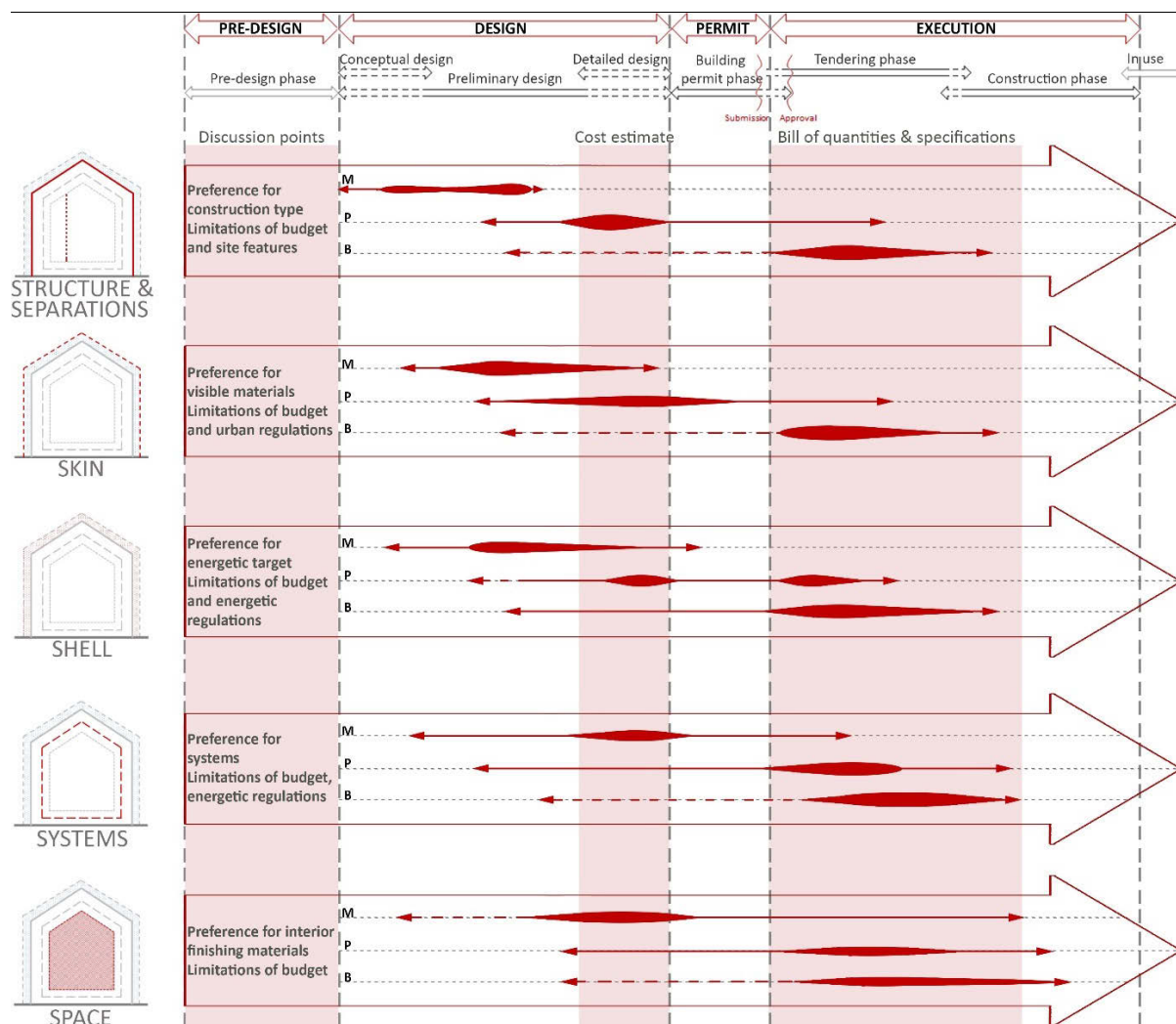

Fig. 2: Material related design decisions for the six building layers on the level of the material category (M), product type (P) and brand or producer (B). Thick arrows represent the gross of the architects, a dotted arrow represents few architects.

### 3.3 Building permit phase

During the building permit phase, materials for the building skin (skin in Fig. 2) must be fixed to a product type level, since these materials have to be in line with the urban planning regulations.

Therefore, this phase is quite crucial for the determination of the building appearance. Architects describe the material type and colour of all visible materials, e.g. the façade, pitched roof, exterior carpentry, and other visible elements. Usually no specification to a brand or

producer level is implemented yet, since colours and even material types (only in exceptional cases) may still change.

### 3.4 Execution phase

During tendering and construction, materials are specified to a brand or producer level in the bill(s) of quantity and/or specification files. In a first instance, tendering files for carcass construction (structure and separations, shell and skin in Fig. 2) are developed. During construction, further detailing of the materials for carcass construction on site may take place (e.g. choice of sills), but the main focus is on specification of building systems (usually starting from a standard package suggested by the architect) and interior finishing materials (systems and space in Fig. 2): specific system types and brands are discussed and specific interior finishing materials (especially flooring materials) are chosen.

Over all, a substantial difference is observed between the actors involved in the specification of visible versus invisible materials. Visible materials (e.g. skin and interior space materials) are generally specified to a very profound level by architect and client, leaving little room for alterations by other actors in the design process. For nonvisible materials (e.g. structure or shell materials), recommendations of the structural engineer and energy expert are taken into account. In addition, contractors and installers may also suggest other materials or products to work with on the construction site [12]. Therefore, the exact contributions of other parties in the design and material decision process is still being investigated in more detail.

## 4 DISCUSSION

As discussed in paragraph 1, this research is conducted to contribute to the development of an architect oriented environmental impact assessment tool, usable from early design on. As the research only includes 14 design cases, the results may not be generalized. However, they do provide valuable information on the material selection process in Flemish dwelling design.

Three possible moments in the design process where an environmental impact assessment calculation of building design could take place

have been identified from the overview of the current practice on material decisions (Fig. 2) and are presented in Fig. 3.

A first intermediate impact calculation can take place in early design stages, after the first meeting with the client and at the beginning of the concept formation. This first assessment is quite valuable, since early design decisions have significant influence on further design development [13]. The format for this calculation could be a very preliminary and intuitive impact calculation based on general design parameters on the building geometry (such as floor area, number of floor levels, typology) and the building materials (intended construction type, façade material preferences, ...). Since information is still rudimentary at this point, this preliminary calculation could result in an impact indication (e.g. a range, order of magnitude) that can serve as a guidance for further design development. In addition, feedback on the architect's preliminary design decisions per building layer and advice on how to improve the impact of their design (by making alterations to the design, picking alternative materials, etc.) could be provided. This impact indication could be linked to early design drawings of the building geometry e.g. in Sketch-Up. Since this indication will mainly be based on assumptions, appropriate default values to replace missing data (material quantities, details on materials/products) should still be investigated in more detail.

A second intermediate impact calculation can take place after the price estimate in detailed design. At this stage, more concrete information of structure, shell and skin materials is available, which can be embedded in an environmental impact assessment with generic LCA data of materials or products. This information would enable the architect to perform intermediate environmental impact assessments of building design options and implement changes if necessary, prior to building permit submission.

A third and final impact calculation can only take place after construction, as some material specifications only occur on site. This calculation can be made starting from the actual materials used on site (starting from brand or producer

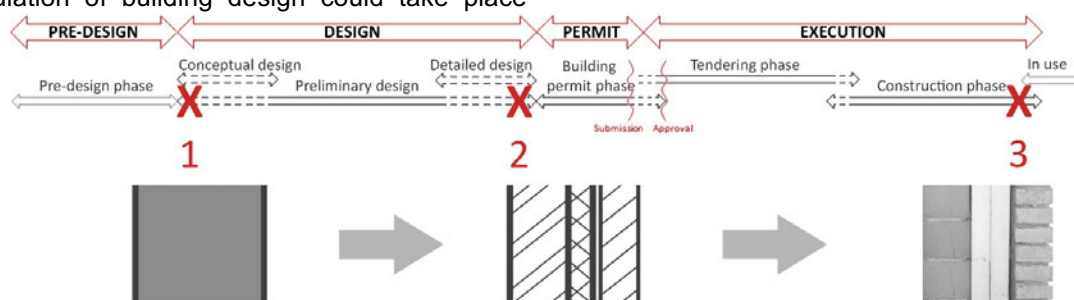

Fig. 3 Three moments for possible environmental impact calculation in the design process and the type of material related design information available at those moments (example for a wall).



specific LCA data, e.g. EPD), based on the available post intervention file or invoices of the purchased materials.

The first two calculations should provide architects with intermediate feedback on their material choices, since they are central actors in the design process and are still able to alter the design at these moments of the design process (if necessary). The final assessment will most likely be outsourced to a specialist (cfr. energy performance calculations), as the architect is usually not involved to the very end of a project. Therefore, it should be investigated to what extent there is a data overlap between energy performance calculation and environmental impact assessment, so that both calculations may be outsourced to the same person.

Furthermore, three out of nine interviewed architects indicate that, after a while, they would adapt their work method to the assessment criteria. This would enable them to skip the first two assessments and go straight to a final (outsourced) assessment (cfr. energy performance calculations). This indicates that the tool could induce a learning process, which is definitely necessary, since previous research [14] already indicated that the (Flemish) architects' knowledge on sustainability and sustainable material use is quite limited. Also, according to one of the interviewed architects, most architects are quite set in their habits. By providing correct and reliable information on the environmental impact of materials in a usable format, they might be triggered to change their custom pattern of decision making. In this context, such a preliminary environmental impact indication can play an important design supportive role.

Further research to investigate the role of other actors (e.g. client, contractor) and possible drivers (e.g. aesthetics, budget) involved in material selection is being conducted. In addition, the environmental impact of the different layers and how to deal with the missing or rudimentary data in the calculations will be investigated. All findings will be implemented in an environmental impact assessment tool that is adapted to the architects' work method and usable from early design on.

## 5 CONCLUSIONS

In this paper, a retrospective case-study analysis (14 cases) and semi structured interviews with nine architects are used to identify the moments and level of specificity of material decisions in the design process.

In early stages, material related information is vague and implicitly taken into account in the shape design. From detailed design on, more concrete material and product information on the building materials becomes available (e.g. in the

cost estimate). The materials for carcass construction (structure and separations, skin and shell) are specified earlier than those for the building's interior (systems and space). During tendering and construction, final material specifications to a brand or producer level occur.

In the context of the development of an architect-oriented environmental assessment tool, three moments for possible environmental impact assessment during building design are identified, being i) after predesign, ii) in detailed design and iii) post construction. Since the first two moments are part of the design process, the architect will most likely be confronted with these impact calculations. Especially the first impact calculation could provide valuable information for further design development.

However, further research is needed on actors and drivers behind material decisions and on the environmental impact of the layers. All findings will be implemented in an architect oriented and design supportive environmental impact assessment tool.

## 6 ACKNOWLEDGMENTS

Research funded by a PhD grant from VLAIO (Agentschap Innoveren en Ondernemen, previously called IWT-Vlaanderen).

## 7 REFERENCES

1. Winters, S., et al., *Wonen in Vlaanderen anno 2013*. De bevindingen uit het Grote Woononderzoek 2013 gebundeld. 2015, Steunpunt wonen: Leuven.
2. The European Parliament and the council of the European Union, Richtlijn 2002/91/EG van het Europees parlement en de raad van 16 december 2002 betreffende de energieprestatie van gebouwen (*in Dutch*). Publicatieblad van de Europese Gemeenschappen, 2003: p. L 1/65 - L 1/71.
3. The European Parliament and the council of the European Union, Richtlijn 2010/31/EU van het Europees parlement en de raad van 19 mei 2010 betreffende de energieprestatie van gebouwen (herschikking) (*in Dutch*). 2010.
4. European Commission, Communication from the commission to the European parliament, the council, the European economic and social committee and the committee of the regions. A resource-efficient Europe - Flagship initiative under the Europe 2020 Strategy. 2011: Brussels.
5. Weytjens, L. and G. Verbeeck, Analysis of the impact of sustainability related design parameters in the architectural design process. A case study research., in 3th CIB International Conference on Smart and Sustainable Built

- Environment (SASBE2009). 2009: Delft, The Netherlands.
6. MRPI. Milieuprestatieberekening (in Dutch). 2016 [cited 2016 January 4th]; Available from: <http://www.mrpi.nl/#!free-tool/c1iwz>.
  7. OVAM, Materiaalbewust bouwen in kringlopen. Preventieprogramma duurzaam materialenbeheer in de bouwsector 2014-2020 (*In Dutch*), D. Wille, Editor. 2013, OVAM: Mechelen.
  8. Gilbreth, F.B. and L.M. Gilbreth, Process charts. 1921: American Society of Mechanical Engineers.
  9. Kumar, P., Process mapping. n.d., Health Quality & Safety Commission: New Zealand.
  10. Quality Learning Australia Pty Ltd, Process mapping. 2006: Australia.
  11. Brand, S., How buildings learn: What happens after they're built. 1994, New York: Penguin Group.
  12. Claes, N. and J. Smetsers, Rol van de aannemer bij de materiaalkeuze tijdens de bouw van eengezinswoningen (in Dutch), in *Industrial Sciences: Construction*. 2015-2016, Hasselt University: Diepenbeek.
  13. Hollberg, A., et al. Application of a parametric LCA tool in students' design projects. in *SBE16 Hamburg - Strategies, stakeholders, succes factors*. 2016. Hamburg, Germany: ZEBAU.
  14. Meex, E. and G. Verbeeck. Practice and knowledge of Flemish architects on sustainable material use. in *EURO elecS 2015: Latin American and European Conference on Sustainable Buildings an Communities*. 2015. Guimarães, Portugal: Multicomp.



## Expanding Boundaries: Systems Thinking for the Built Environment

### ECONOMIC FLOW ANALYSIS OF CONSTRUCTION PROJECTS TO SUPPORT SUSTAINABLE DECISION-MAKING

D. Ioannidou<sup>1\*</sup>, S. Zerbi<sup>2</sup>, G. Habert<sup>1</sup>

<sup>1</sup> Chair of Sustainable Construction, ETH Zurich, Stefano Franscini Platz 5, 8093, Zurich

<sup>2</sup> hepia - Haute école du paysage, d'ingénierie et d'architecture de Genève, Rue de la Prairie 4, 1202, Geneva, Switzerland.

\*Corresponding author; e-mail: ioannidou@ibi.baug.ethz.ch

#### Abstract

Economy is one of the three pillars of sustainability and one of the parameters taken into account by many green building labels. In the construction industry, there exist many methods that evaluate the project cost; however, none of the current methods takes into account the location of the economic flows or the final stakeholders that benefit from them. This paper proposes a new methodology for tracing the economic flows of a project, by classifying costs into 5 categories: labour, materials, energy, infrastructure, taxes and overhead and in two levels: local and regional. The aim is to facilitate economic decision making for local authorities, construction managers and project investors and to make the social dimension of these flows and the generalized impact of the project on the local society apparent. The applicability of the new methodology is tested through some case studies. It is observed that such an analysis provides useful insights with respect to the economic flows going to direct labour vs overhead and taxes as well as regarding the spatialized distribution of the cost of a project.

#### Keywords:

economic flows; construction cost; labour; materials; taxes and overhead

## 1 INTRODUCTION

The demands of society for a sustainable development have placed strong emphasis on the ecological aspect of construction projects. The assessment of the environmental impacts of a project is widely performed with the help of Life Cycle Assessment [1], [2]. At the same time, the other two pillars of sustainability, economy and society, need to equally be taken into account in the planning phase. The assessment of the economic and social impacts is underlined by many sustainability labels and is part of the Sustainability Life Cycle Assessment in an attempt to provide an overview of the effects of a project.

With respect to the economic impacts, there exist many methods which are used to facilitate economic decision making in a project and are related to the evaluation of cost at different phases and levels of activity. Among the most widely used methods are Life Cycle Costing [3], Supply Chain Management [4], Material Flow Cost Accounting

[5], [6] and Input – Output Analysis [7], [8].

However, none of the above methods can provide organized information of the flows of money in a project, their spatial characteristics and who the final recipients are. For this reason, we developed a new way of assessing the economic relationships in a project in order to understand the economic transformation of the society. This new methodology presents in a visual way the economic flows by categorizing them in broader classes. It is efficient in capturing the various transactions in the project and making visible whether the construction is labour intensive or relying mostly on overhead. It can also reveal whether the project is beneficial for the local community and contributes to its economic development. Therefore, it can facilitate economic decision making for investors and project owners, who can trace the route of their investment and identify the final recipients and make conscious choices that will affect the “social” return on their

investment (the social groups that will benefit from it). It can also provide a map of the economic and, to an extent, social relationships between the different stakeholders of a project. A description of the methodology follows, accompanied by two case studies: the construction of a stone bridge in France and a building complex made of stone in Greece.

## 2 METHOD

In order to provide a framework for studying the economic flows in a project, we adopted the tiered approach of the supply chain management. Every tier (Figure 1) corresponds to a different level of analysis: project level, local, national and general level. The first tier of the model (project level) assembles all the costs incurred in the specific project. These costs are then distinguished to local and national in the second tier, depending on whether the manufacturer or stakeholder is locally or nationally located. The third tier represents the project costs and is similar to the first tier, but the cost categories include both direct and indirect costs. For example, the labour category includes not only the salaries of the employees working on the construction site, but also the indirect labour required in order to produce the materials to be used in this project (concrete, steel, glass etc....). Regarding the cost breakdown structure, we defined the following 5 components of cost, in accordance with the categorization followed in previous studies [3], [9], [10], [11]:

- Labour. This category includes the employees' salaries and all expenses related to their health and accident insurance, social security and the contribution to the pension scheme.
- Materials. This category encompasses all costs related to the purchases of the materials used in the construction process, excluding VAT.
- Energy. Here belong the expenditures related to fuel and electricity. Transportation is indirectly taken into account in this category.
- Infrastructure. This category includes all fixed and intangible assets of the company, which are indispensable for the production process. For example, the rent or lease of office or equipment and the depreciation and maintenance of machines. Here also belong the expenses related to the repair or maintenance of the infrastructure.
- Taxes and overhead. As overhead costs of a project could be classified the head office expenses, head office staff wages, taxes, fees, automobile expenses, financial costs, uncollected receivables and miscellaneous [12], [13].

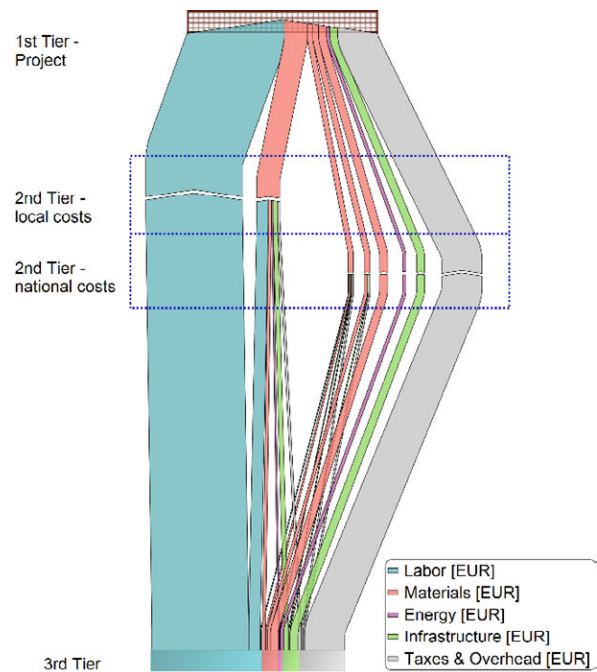

Fig. 1: Example of an economic flow diagram.

Figure 2 shows the source of data for each tier of analysis for already completed projects. Project invoices can provide us with data for most of the project costs, namely labour, materials, energy as well as the taxes paid and the overhead costs incurred (such as office and automobile expenses). Regarding the infrastructure used for a project, this can be allocated to the specific project in proportion to the time it has been used, considering the whole life cycle of the infrastructure.

In order to break down the manufacturing cost of each single material to its components, for the second tier of analysis, we have recourse to the corresponding production companies and to their income statement. In this way, we can determine which part of their production costs went to labour, materials, infrastructure etc. Any external charges, i.e. payment to subcontractors, included in the income statement are excluded from our analysis. In most of the income statements, this amount is less than 7% and most likely related to overhead or labour costs. For a complete and thorough assessment, the method that should be followed would be to find the subcontracting companies and analyse the amount paid to them with respect to the 5 categories.

If an analogy to Life Cycle Assessment (LCA) is attempted, then the first tier of analysis in our methodology, where data is extracted from the specific project invoices, would be similar to the foreground data collection. The second tier of analysis could be seen as collection of generic, not project specific data. This is close to the background data in LCA, which is usually based on generic databases and contains average values regarding the Life Cycle Inventory of various processes (e.g. Ecoinvent database [14]).

Finally, the third tier of analysis consists of the addition of the quantities of the second tier and allows to gather all direct and indirect contributions in each category.

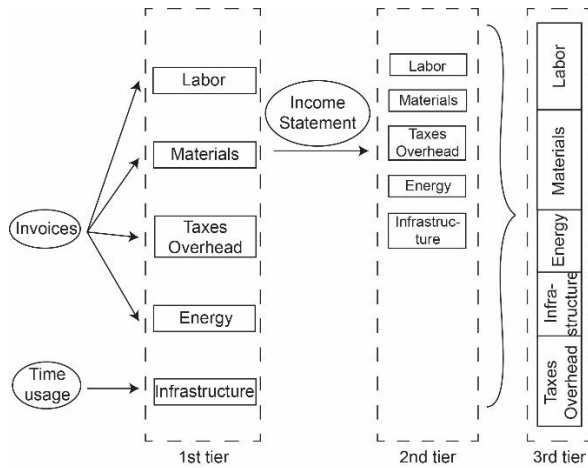

Fig. 2: Source of data for each tier of analysis.

### 3 RESULTS

The methodology presented above was applied to two case studies: the construction of a stone bridge in France and a building complex made of stone in Greece.

#### 3.1 Construction of the Chaldecoste Stone Bridge

##### Project Description

The first case study was the project of construction of the Chaldecoste Bridge, in the south of France. The new stone bridge has a span length of 6 m and a width of 4.8 m (Figure 3). The stone solution was preferred, because the mayor wanted to use the local resources and the local workforce and respect the vernacular architecture [15]. Its construction was performed by four local artisans under the guidance of the engineering office S etra and IFSTTAR (French Institute of science and technology for transport, development and networks).

##### Data collection

Regarding the first tier of analysis, the economic data of the project enabled us to categorize the costs into the 5 defined categories. The remuneration of the design office was classified as national overhead. Although for a full analysis we should further breakdown this amount to labour, materials, taxes etc., due to lack of information this amount was carried forward to tiers 2 and 3 intact as taxes and overhead.

With respect to the materials used for the construction of the bridge, these were (Figure 4): stone, backfill, formwork, cement, sand, lime, earthwork and coating. The cost breakdown at the first tier was performed based on the project

invoices, while for the second tier, we extracted data from the financial statements of the relevant companies. For example, the cost allocation for concrete was based on the income statement of the French cement and concrete producer, Lafarge. When no statements were publicly available for a French manufacturing company, an international company of this field was selected for performing the cost breakdown. Finally, concerning the formwork production for the bridge, since no publicly available data could be found for the production of the material, the total economic flow was assigned to the "Material" cost category and carried forward "as is" to the other levels.

##### Results

The Sankey diagram (Figure 4) shows the costs repartition. At the third tier of analysis, labour costs amount to 68% of the total project costs. Material costs account for only 9%, energy for 1.5%, infrastructure for 8% and taxes and overhead for 13.5%. Regarding the cost breakdown between local and national, the construction of the stone bridge induces a flow of 77.6% of the total project cost going back to the local community.



Fig. 3: View of the Chaldecoste bridge.

#### 3.2 Construction of a complex of 5 independent stone houses in Nafplion

##### Description of the project

In the second case study, we examined the construction cost for a complex of 5 independent stone houses in Nafplion, Greece. The structure of the houses is made of reinforced concrete and the walls from brick and stone (Figure 5). Stone was selected for the construction, because it is a characteristic material of the Greek landscape and is largely available in the area. Local crew was preferred for the construction and a local engineering office designed the complex and issued the permits. However, the accounting office hired was situated in Athens.

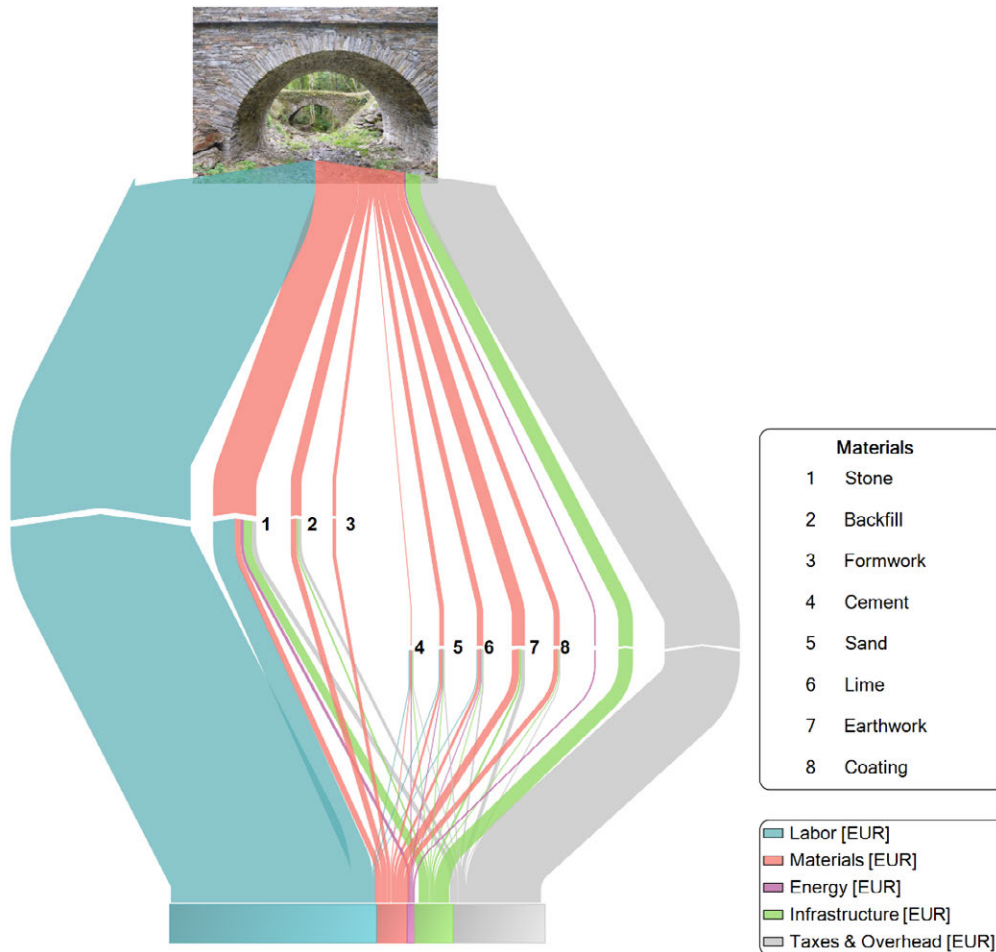

Fig. 4: Economic flow diagram for the construction of the Chaldecoste bridge.

#### Data collection

General expenses include the engineering office, the accounting office and the legal services for the project. In the national materials, some products which had a total contribution of less than 5% to the overall project costs, namely plumbing materials, bathroom appliances and roof tiles, were aggregated under “Others” and as with the case study of the stone bridge, the total economic flow was assigned to the “Material” cost category. Since these costs do not represent a significant percentage of the total expenses (less than 5%), the error is minimal.

#### Results

The cost allocation for the project is shown in Figure 6. Labour costs in the third tier amount to 51% of the total project costs, materials to 13%, energy to 5.5%, infrastructure to 7.5% and taxes and overhead to 23%. In addition, it is observed that the construction of the stone houses, with the employment of local workforce, results in 69.5% of the total project cost going back to the local community. It should also be considered here that many materials that are not produced in this area, had to be transported from outside the region, thus increasing the percentage of national costs.



Fig. 5: View of the complex of stone houses in Nafplio.

## 4 DISCUSSION

The two previously presented case studies show the breakdown of the project costs in national and local contributions. The analysis can help derive a series of observations with respect to the cost structure of the projects, the main stakeholders benefiting from them and also the utility of the projects for the local community from an economic point of view.

Regarding the main stakeholders of the projects, in both cases, labour costs are significantly higher than taxes and overhead (the former costs are more than half as much as the latter). This was anticipated, as stone is a labour intensive material,

in contrast to more industrialized materials, such as concrete.

Another interesting observation concerns the location of the project costs. In both projects, the majority of the project costs returns to the local community. In the case of the bridge, a local material (stone) was used with delocalized overhead, whereas in the case of the stone houses, the same material was used in combination with a local engineering office. When the overhead is not local, part of the project cost is diverted outside the local community. Taking into consideration the idea of localization of Moffatt and Kohler [16], the case studies prove that the solution yielding the most significant benefit for a local community is when a local material with on-site know-how is employed. The suitability of a material for a certain project depends on the benefits created for the local economy and the local society, which can be observed in the Sankey diagrams.

With respect to the location of the production of the various materials (Figures 4 and 6), for some products it could be debated whether they should be categorized as local or national. For example, this is the case of the window aluminium frames in Figure 6; the components of the window frames were produced outside Greece and were transported to Nafplion, where was performed the final assembly. In the model, this is represented as a national cost, since only a small percentage of the cost actually is attributed to the local community.

Furthermore, energy and infrastructure costs are in both studies assigned to the national level. Regarding energy costs, this is a reasonable assumption because both the production of electricity and the extraction of the fuel are not taking place in the vicinity of the projects. As regards infrastructure, this is in each case partly local and partly national. For example, here can belong a local office, the company's vehicles and machines as well as investment on software etc. The main part of these costs is not returning to the local community, therefore they have been classified as national. Additionally, the error from not allocating the infrastructure costs is negligible, since these costs (at the project level) amount to a maximum 4% of the total costs of the project in all case studies.

Of course, a full comparison of the two case studies is not possible, because the structures are located in different regions, with different characteristics (network of suppliers, earthquake profile) and serve totally different purposes (a big infrastructure project vs a residential complex).

It should be mentioned that the methodology developed in this paper accounts only for the construction cost of a project but could be also expanded to account for the whole life cycle of a structure, by including the maintenance phase.

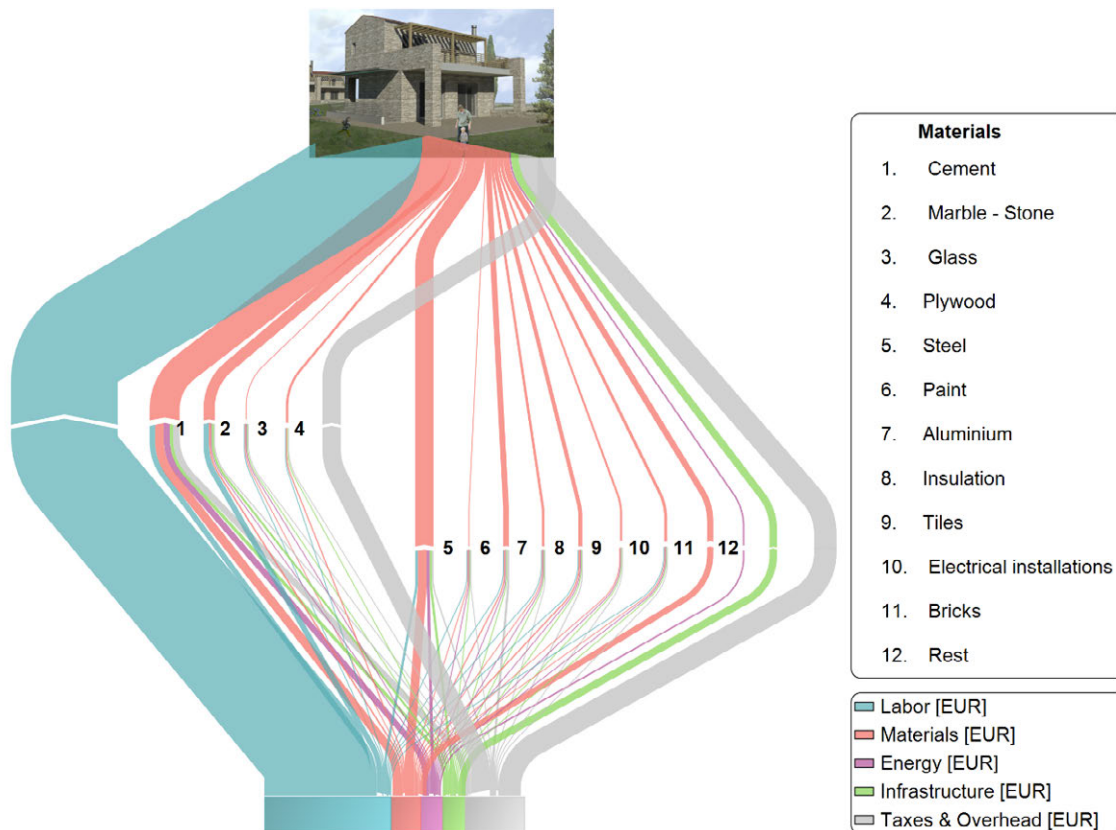

Fig. 6: Economic flow diagram for the construction of the residential stone buildings in Nafplio.

## 5 CONCLUSION

This paper presents a new methodology for assessing the economic flows in a project. The aim is to enable a more sustainable decision making that considers the economic transformation of a society as a result of a construction project. In the presented methodology, the cost of a project was divided into five categories and to a local and national level. The material production cost was further broken down by accounting for the cost structure of the manufacturing companies. The cost model of the project was graphically represented by the aid of a Sankey diagram.

The application of the methodology to two case studies led to interesting observations with respect to the benefit of the local communities from a specific project as well as the stakeholder category that has the highest contribution to the total cost. This analysis enables project owners and local authorities to make decisions on the choice of materials and the selection of workmanship/overhead that will reinforce the local economy. An economically sustainable strategy could, for example, lead to a project where the local know-how would be favoured by the choice of a material leading to a better construction design and execution of the project.

## 6 ACKNOWLEDGMENTS

The authors would like to thank Konstantinos Ioannidis and Lacratis Constructions Partnership for their invaluable help in providing all information and data for the project in Nafplion. We would also like to thank Chiara and Giuseppe Ongaro for providing data on stone production.

## 7 REFERENCES

- Hellweg, S. and L. Mila i Canals, Emerging approaches, challenges and opportunities in life cycle assessment. *Science*, 2014. 344(6188): p. 1109-13.
- Ioannidou, D., et al., When more is better – Comparative LCA of wall systems with stone. *Build Environ*, 2014. 82, p. 628-39.
- Bierer, A., et al., Integrating life cycle costing and life cycle assessment using extended material flow cost accounting. *J Clean Prod*, 2015. 108: p. 1289-301.
- Beske, P. and Seuring, S., Putting sustainability into supply chain management. *Supply Chain Management: An International Journal*, 2014. 19: p. 322-31.
- Schmidt, A., et al., Extending the scope of Material Flow Cost Accounting – methodical refinements and use case. *J Clean Prod*, 2014. 108: p. 1320-32.
- Sygulla, R., et al., Material Flow Cost Accounting: A Tool for Designing Economically and Ecologically Sustainable Production Processes, in: Henriques, E., Pecas, P., Silva, A. (Eds.), *Technology and Manufacturing Process Selection*. 2014, Springer London, p. 105-130.
- Miller, R.E. and Blair, P.D., *Input – Output Analysis. Foundations and Extensions*. 1985, Prentice-Hall Inc., Englewood Cliffs, New Jersey
- Nathani, C., et al., Estimation of a Swiss input-output table for 2001. *CEPE Report*. 2006.
- DOC Department of Commerce, 2002 economic census, industry summary: Construction. Subject series, EC02-23SG-1. 2005. Economics and Statistics Administration, U.S. Census Bureau, Washington, D.C.
- Xiao, H. and Proverbs, D., The performance of contractors in Japan, the UK and the USA: a comparative evaluation of construction cost. *Construction Management and Economics*, 2002. 20: p. 425-35.
- Tsai, W.-H., et al., Integrating the activity-based costing system and life-cycle assessment into green decision-making. *Int J Prod Res*, 2014. 53: p. 451-65.
- Assaf, S.A., et al., The management of construction company overhead costs. *Int J Proj Manag*, 2001. 19: p. 295-303.
- Plebankiewicz, E. and Leśniak, A., Overhead costs and profit calculation by Polish contractors. *Technological and Economic Development of Economy*, 2013. 19: p. 141-61.
- Kellenberger, D., et al., Life Cycle Inventories of Building Products, Data v2.0.ecoinvent report No. 7. 2007. Dubendorf: Swiss Center for Life Cycle Inventories.
- Colas, A.-S., et al., Holistic approach of a new masonry arch bridge on a Cevennes road. in 9<sup>th</sup> International Masonry Conference. 2014: Guimaraes, Portugal.
- Moffatt, S. and Kohler, N., Conceptualizing the built environment as a social-ecological system. *Build Res Inf*, 2008. 36: p. 248-68





## Expanding Boundaries: Systems Thinking for the Built Environment

### URBAN PLANNING AND SOLAR POTENTIAL: ASSESSING USERS' INTERACTION WITH A NOVEL DECISION-SUPPORT WORKFLOW FOR EARLY-STAGE DESIGN

E. Nault<sup>1\*</sup>, L. Pastore<sup>1</sup>, E. Rey<sup>2</sup>, M. Andersen<sup>1</sup>

<sup>1</sup> Interdisciplinary Laboratory of Performance-Integrated Design (LIPID), Ecole polytechnique fédérale de Lausanne (EPFL), Station 18, CH-1015 Lausanne, Switzerland

<sup>2</sup> Laboratory of Architecture and Sustainable Technologies (LAST), Ecole polytechnique fédérale de Lausanne (EPFL), Station 16, CH-1015 Lausanne, Switzerland

\*Corresponding author; e-mail: emilie.nault@epfl.ch

#### Abstract

The need for sustainable architecture and urban design and planning has long been acknowledged, along with the necessity for adequate, early-phase guiding instruments. This paper aims at exploring the effectiveness and usability of a novel decision-support workflow for neighbourhood-scale projects, developed to provide practitioners with early-stage design alternatives in an interactive and iterative sequence. The prototype includes a performance assessment engine, which quickly computes an estimate of the daylight and passive and active solar potential for each design alternative. To assess the added value for design and the educational features offered by the workflow, workshops were organized with architects and urban planners. Participants were asked to work on a realistic micro-urban design project by means of two different approaches: making use of their conventional tools and methods, and then using the prototype. In addition to these design phases, the workshop included ranking design alternatives with respect to their performance before and after using the prototype, and filling pre- and post-workshop questionnaires to gather the participants' level of experience and their feedback. The main outcomes from these tasks show that the prototype yields a strong potential in terms of design guidance, despite mixed results in the level of success in the before and after ranking phases. Results also highlight the necessity to pursue the development and adoption of energy oriented early-stage design instruments.

#### Keywords:

early-design; decision-support; urban design; solar potential

## 1 INTRODUCTION

The increasing necessity for the building sector to comply with various normative frameworks [1,2] and energy rating systems [3] has led to the spread of integrated design processes, supported by multi criteria design tools, aimed at addressing urban planning and architectural practices in a more holistic and sustainable way [4,5].

In the specific context of early-phase neighbourhood projects, practical use of developed tools and methods remain limited, particularly due to their lack of guidance and

integration within the design process [6,7]. Most programs are conceived for analysis rather than design, leading them to be used mainly at the detailed stage [6]. As a result, some architectural features are found to be unfavourable for the minimization of buildings' energy need only when the process is already at an advanced stage and changes are no longer possible.

Most existing design decision-support methods and tools are conceived to perform a full simulation of a unique building [8,9], task of a certain level of complexity in terms of inputs and

computational time. At the urban-scale, existing methods cover the need for a relatively fast assessment through a user-friendly interface [10] and for detailed comprehensive energy flow assessment [11]. However, such tools require information typically unknown at the early-design phase (e.g. material), provide limited guidance, and are not designed to generate and compare design alternatives. To better target current shortcomings, it is essential to give greater importance and care to the design process when developing decision-supports.

As an attempt to do so and to address the mentioned limitations, a workflow was developed to support decision-making, targeting the assessment of the performance of early-design neighbourhood projects. The performance is here defined as (i) the passive solar, (ii) daylight and (iii) active solar potential. To verify whether our proposed workflow could fulfil its intended role, it was implemented as a prototype that was tested through workshops organized with practitioners.

## 2 OVERVIEW OF TESTED PROTOTYPE

The core of the prototype is coded in C# and packaged as a Grasshopper (<http://www.grasshopper3d.com/>) plug-in for Rhino (<https://www.rhino3d.com/>), with a customized interface for gathering the user-inputs. It also makes use of additional Grasshopper plug-ins: DIVA-for-Grasshopper [9] and Lunchbox (<http://www.theprovingground.org/>). Users provide an abstracted neighbourhood base design by positioning building points and specifying ranges of variables to explore (e.g. min-max height). A series of design alternatives (or variants) is then automatically generated by the prototype's engine, by randomly sampling from the specified variables ranges. Geometrical parameters such as the plot ratio and overall form factor are computed for each variant, as well as irradiation-based parameters (e.g. south-façade mean annual irradiation), following an irradiation simulation. These serve as inputs to the performance assessment engine that computes an estimate, through predictive mathematical functions, for the energy need for heating and cooling (indicator of the passive solar potential) and for the spatial daylight autonomy (indicator of the daylight potential). These predictive functions take the form of a multiple linear regression, defined from a dataset of simulated values for various neighbourhood designs, taken as reference and further detailed in [12]. The main advantage of this approach compared to a standard simulation is a reduced computational-cost and complexity. The third criterion – the active solar potential in terms of energy production from roof-mounted systems – is computed by an algorithm based on an

irradiation threshold. Finally, the generated and assessed design variants are shown in the form of an irradiation map with a panel containing the corresponding information (e.g. building dimensions), along with graphs showing the relative performance of all variants with respect to the three criteria. More details on the workflow and its implementation can be found in [12].

This paper details the approach adopted to test the prototype through workshops, and presents the main outcomes from specific workshop tasks.

## 3 WORKSHOP

### 3.1 Objectives

The main goals of the workshops were to:

- (i) assess the potential of the proposed workflow as a solar/energy performance-based design decision-support method for the early-design phase of neighbourhood projects
- (ii) verify if the workflow could bring new knowledge and help improve the performance of a design
- (iii) identify bugs and improvements in the interface and workflow
- (iv) assess the predictive accuracy of the underlying mathematical functions

In this paper, we present results for points (i) and (ii) only, focusing on the potential usability and added value of the prototype.

### 3.2 Participants

Three workshop sessions were organized; a first test-run was conducted with four colleagues, followed by two 'official' sessions with four professionals each, amounting to 12 participants in total. Participants consisted in one engineer and 11 architects, of which 4 declared themselves urban designers as well. Experience levels ranged from 1 to 15 years.

### 3.3 Schedule and tasks

The schedule of the workshop is shown in Fig. 1. Prior to the event, participants were asked to fill a questionnaire including questions on their level of experience with tools and performance assessment methods. The workshop began with a brief introduction to the tasks and performance criteria addressed by the proposed prototype as introduced earlier. Participants were then asked to provide a neighbourhood design solution consisting in the composition of mix-used buildings for a given existing area (112 m by 87 m) of the city of Lausanne (adapted from a master plan [13]). The design process was split in two stages corresponding to two different design variants; participants first designed variant A (VA), using their usual design techniques and tools (e.g. common modelling software – SketchUp, Rhino, etc. – and/or physical 3D model), then provided a revised design, variant B

(VB), following the prototype test. The reason for requesting two design variants lies in the fact that we wanted to compare designers' common approach (VA), and the possible improvement obtained following the use of the prototype (VB).

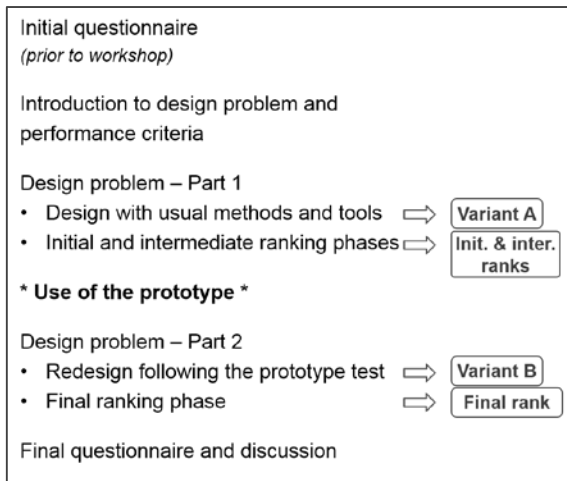

Fig. 1: Workshop schedule and tasks.

To test participants' capacity in estimating the relative performance of a set of designs in relation to the three main solar criteria considered by the prototype, the design phases were spaced out by three ranking tasks: two (initial and intermediate) performed after the generation of VA, and a final one carried out after the generation of VB. The initial task consisted in ranking, with respect to each solar criterion, four design variants: participant's VA and three other given design variants (V1-V3). In the intermediate phase, the actual performance of V1-V3 were disclosed and based on this new knowledge, participants had to rank their VA a second time, as shown in Fig. 2.

After the initial and intermediate ranking tasks, participants were shown a demo of the prototype to be tested and given instruction sheets before proceeding with the test and the development of VB. They had to re-create something similar to their VA and explore the generated variants to see if they could improve their design. In the final ranking task, they were then asked to rank this last variant, along with an optional revised rank for VA, again relative to the known V1-V3. The workshop concluded with a questionnaire to collect the participants' impression and suggestions. Following the workshops, all variants VA and VB were modelled and simulated (as previously done for V1-V3) to verify if the orders from the ranking phases were correct, i.e. matching the simulation values taken as reference. In the next section, we attempt to provide answers to goals (i) and (ii) introduced earlier by looking at the results from the questionnaires and ranking phases.

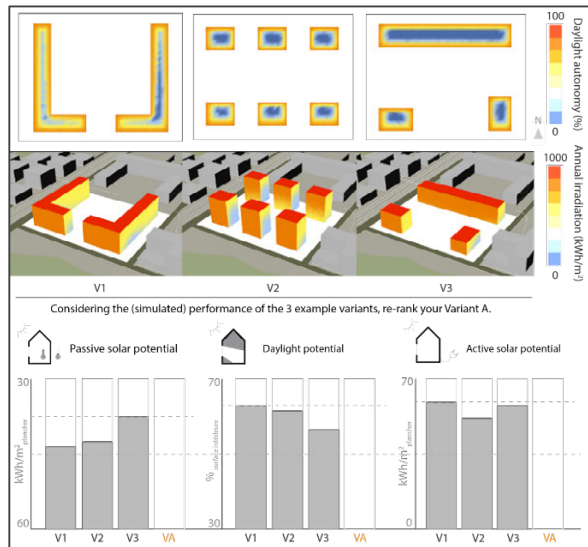

Fig. 2: Sheet given to the participants for the Intermediate ranking phase.

## 4 RESULTS

### 4.1 Initial questionnaire

The initial questionnaire contained questions related to the background and level of experience of the participants. Fig. 3 summarizes the results regarding the type of assessment typically conducted at the early and detailed design phase for each performance criterion of interest in the current context of the prototype and workshop. In the rather rare cases where an assessment is done, it generally occurs at the early phase through the application of simple methods such as rules of thumb and visualization (e.g. sun path diagram). External consultants are solicited to some extent both at the early and detailed phases across all performance criteria, while simulation is conducted, here by a small portion of participants, mostly for daylight and active solar potential assessment.

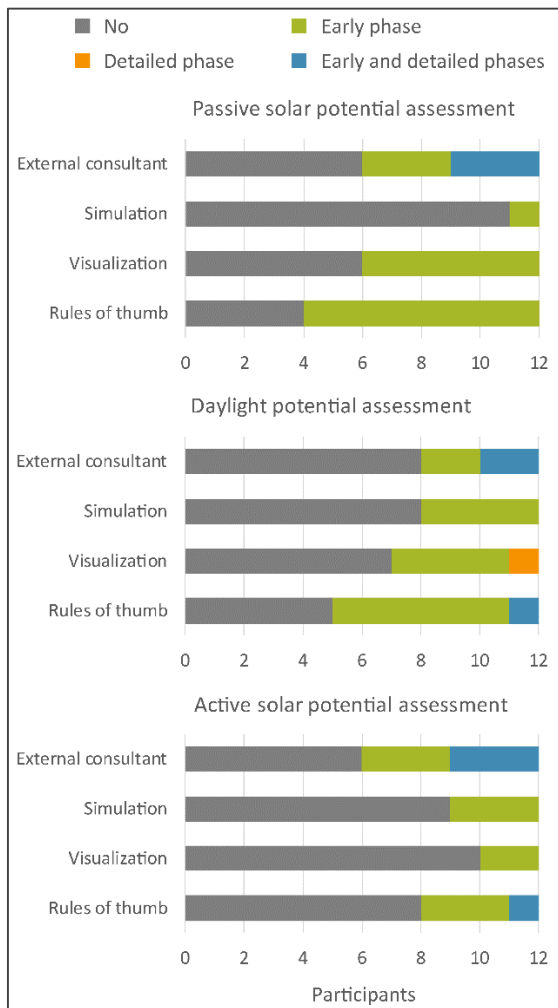

Fig. 3: Results from the initial questionnaire regarding the type of performance assessment typically conducted.

#### 4.2 Ranking of variants

To test the educational feature of the prototype, we asked participants to rank a series of designs with respect to each of the three performance criteria in different phases, as explained earlier. To analyse the answers, we computed the Kendall rank correlation coefficient, which evaluates how similar are two sets of ranks assigned to the same set of objects [14]. This value depends on the number of inversions of pairs of objects between the two ranks. A value of 1 (respectively -1) indicates a perfect (resp. inverse) correlation, i.e. that, in this case, the rank provided by the participant is the same (resp. opposite) as the rank resulting from the simulation of the variants (reference value).

Results are shown for each ranking phase and participant in Fig. 4 for the passive solar and daylight potential. The most striking observation is the general increase in the success rate between the initial and the intermediate ranking phase. This jump can be explained by the fact that participants had to directly rank only one variant (VA) in the second phase as opposed to four in the first one, task that was furthermore facilitated by viewing the

performance of the provided examples (V1-V3). From the second to the third ranking phase, results are less consistent. First, it is to note that three participants (numbered 5, 9 and 10 in the graphs) could not fulfil all workshop tasks due to technical difficulties linked to reproducing their variant A in the prototype and as such, did not provide a variant B and final ranking. Among the other participants, there is no trend for the passive solar potential; the final rank was either fully correct as in the intermediate phase (participants 1, 2, 4), better (part. 6 and 11), or worse (part. 3, 7, 8, 12). As for the daylight criterion, there was one perfect ranking for both the intermediate and final phases, while there was an increase for four participants and a decrease for another four.

However, when we compare results from the initial to the final ranking phase with abstraction of the intermediate phase and for both criteria, we observe an increase in 13 out of 18 cases (72%), or an overall jump (for all participants) from 0.19 to 0.62 and from -0.25 to 0.47 for the passive solar and daylight potential respectively, as shown in Fig. 5.

Possible explanations for these mixed results may be found in the rather short timeframe of the workshop and the current capacity of the underlying performance assessment engine, which both imposed limits on design flexibility. These limits had an impact from a 'time to think' perspective but also from a tool functionality perspective, because design options allowed by the tool were restricted to a pre-defined range to make sure the prototype could generate alternatives and evaluate them. While the former may have limited the opportunity to fully assimilate and explore performance results for alternative options, the latter may have diverted the participants' attention towards trying hard to overcome this pre-defined range rather than learning from the tool in its present form.

#### 4.3 Final questionnaire

When answering the open questions of the final questionnaire, some participants mentioned realizing that their intuition was not always correct and that such a tool could be very useful for them. Other qualitative results collected shed an optimistic light on the outcome of the workshops. The main positive feedback gathered relates to the interface and general approach of the prototype: intuitive, interactive, easy to understand and use, complementary to existing tools, promising. The predominant weaknesses are linked to the current limitations in the number and types of user-inputs and the generation of variants: more flexibility or precision required in inputs to enforce specific typologies and ensure credible designs, difficult to visualize and compare variants in synthetic way.

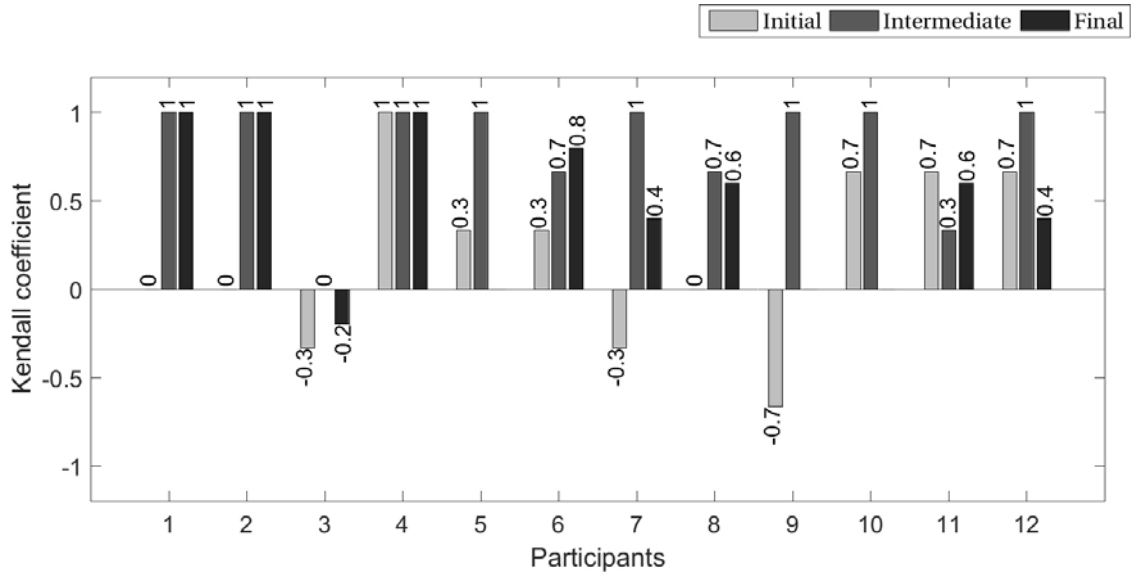

(a) Passive solar potential criterion

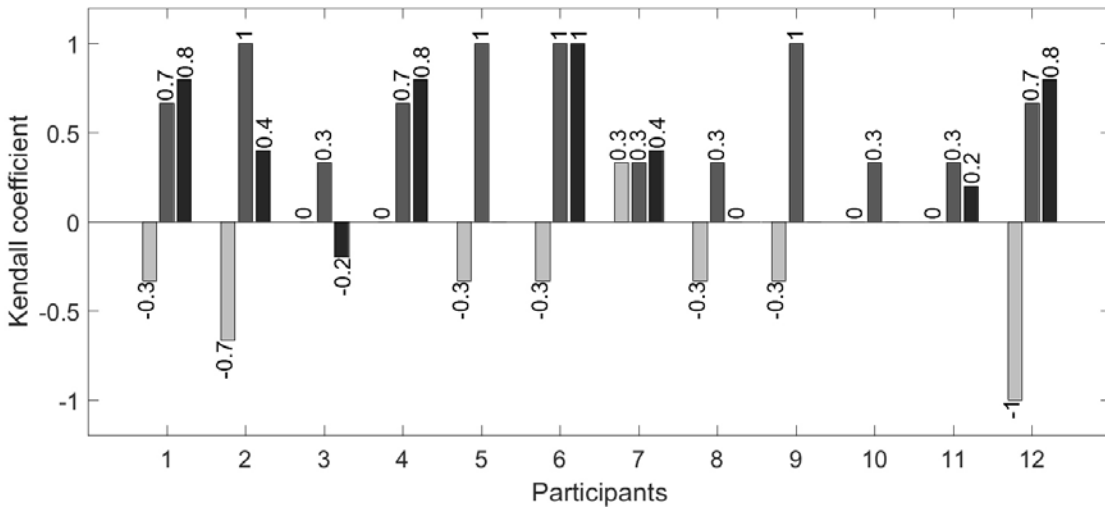

(b) Daylight potential criterion

Fig. 4: Level of success in ranking the design variants for the (a) passive solar potential and (b) daylight criterion, for each participant and phase.

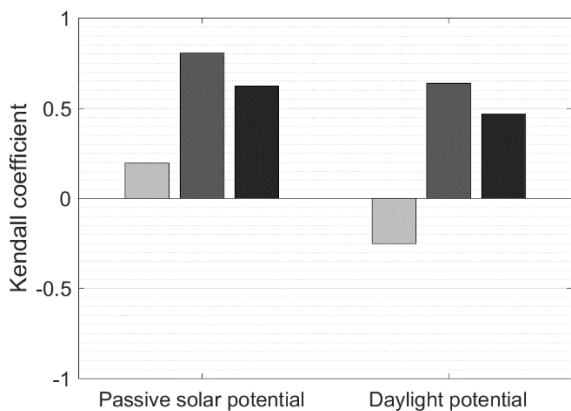

Fig. 5: Level of success in ranking the design variants over all participants at each phase.

Multiple suggestions were also given to overcome the current limitations and to expand the usability and relevance of the prototype, such as by adding specific parameters (e.g. maximum

distance between buildings) and providing an automatically generated summary report.

**4.4 Main findings**

Regarding the potential of the workflow as a decision-support (workshop goal (i)), we observe that the objectives which we intended to fulfil in terms of prototype features – integration within the design process, relevance of approach, simplicity of user-inputs, intuitiveness of workflow and interface – were asserted by a majority of participants through their feedback, and by the fact that they could all easily use the prototype, despite their overall low experience level with performance assessment tools.

As to verifying if the workflow could bring new knowledge and help improve a design's performance (workshop goal (ii)), we conclude from this first test that these goals can only be achieved if design flexibility is increased significantly, so as to enable highly customized

building massing options. A new workshop with a revised format will thus be needed, that includes more participants and extends the timeframe, so as to enable a dedicated focus on assessing the educational potential of the prototype.

## 5 CONCLUSION

A workflow was developed and implemented as a prototype for supporting energy-conscious decision-making at the early phase of neighbourhood projects. Put to test through workshops with practitioners, the prototype appears as highly promising in terms of the relevance and usefulness of its approach, as well as its intuitive and simple interface.

Future work will include integrating suggestions made by participants particularly to allow a larger design flexibility, and addressing the technical issues – expected due to the youth of the prototype. The latter were identified as straightforwardly solvable.

Finally, we will investigate the possibility of replacing or coupling the currently random generation of design variants with an optimizer (such as a genetic algorithm) to better guide the search for performing alternatives.

## 6 ACKNOWLEDGMENTS

This work was conducted at the Ecole polytechnique fédérale de Lausanne (EPFL) with additional support from the EuroTech Universities Alliance and the SECURE (Synergistic Energy and Comfort through Urban Resource Effectiveness) project funded by the CCEM (Competence Center Energy and Mobility) (E. Nault).

The authors would like to thank all workshop participants, as well as Mélanie Huck, Sergi Aguacil, Loïc Fumeaux, Parag Rastogi, Giuseppe Peronato and Lorenzo Cantelli for their contribution and support in the organization of the workshops.

## 7 REFERENCES

1. SIA. Objectifs de performance énergétique SIA. 2008.
2. SIA. SIA 380/1 Thermal Energy in Buildings. 2009.
3. MINERGIE Building Agency. The MINERGIE - Standard for Buildings. Bern, Switzerland: MINERGIE; 2008.
4. Moe, K., Integrated Design in Contemporary Architecture. Princeton Architectural Press, 2008.
5. Kristinsson, J., Integrated Sustainable Design. Delft digital press, 2012.
6. Beckers B, Rodriguez D. Helping architects to design their personal daylight. WSEAS Trans Environ Dev. 2009;7(5):467–77.
7. Hensen J, Lamberts R, editors. Building performance simulation for design and operation. London; New York: Spon Press; 2011.
8. Tindale A. DesignBuilder Software Ltd. 2005.
9. Jakubiec JA, Reinhart CF. DIVA 2.0: Integrating daylight and thermal simulations using Rhinoceros 3D, Daysim and EnergyPlus. In: 12th International Conference of International Building Performance Simulation Association. Sidney, Australia: IBPSA; 2011.
10. Reinhart CF, Dogan T, Jakubiec JA, Rakha T, Sang A. UMI - An urban simulation environment for building energy use, daylighting and walkability. In: 13th International Conference of International Building Performance Simulation Association. Chambéry, France: IBPSA; 2013.
11. Robinson D, Haldi F, Kämpf J, Leroux P, Perez D, Rasheed A, et al. CitySim: Comprehensive micro-simulation of resource flows for sustainable urban planning. In: 11th International Conference of International Building Performance Simulation Association. Glasgow, Scotland: IBPSA; 2009.
12. Nault E, Rey E, Andersen M. A multi-criteria performance-based decision-support workflow for early-stage neighborhood design. Submitted to the 32th Passive and Low Energy Architecture Conference. Los Angeles: PLEA; 2016.
13. Urbaplan. Plan Directeur Localisé Intercommunal Lausanne-Vernand - Romanel-sur-Lausanne. Cahier 1 - Rapport d'aménagement. V.1.3.; 2015.
14. Abdi H. The Kendall Rank Correlation Coefficient. In: Encyclopedia of Measurement and Statistics. Thousand Oaks (CA): Sage; 2007.



## Expanding Boundaries: Systems Thinking for the Built Environment

### INCREASE THE EFFICIENCY IN SUSTAINABLE CONSTRUCTION USING BIM

Carsten K. Druhm<sup>1\*</sup>, Simon Ashworth<sup>2</sup>, Heinz J. Bernegger<sup>2</sup>

<sup>1,2</sup> Institute of Facility Management, ZHAW School of Life Sciences and Facility Management, Grüental, P.O. Box, 8820 Wädenswil, Switzerland

\*Corresponding author; e-mail: carsten.druhm@zhaw.ch

#### Abstract

The assessment of the degree of sustainability (environmental, social and economic) of real estate assets became possible through the development of standards and certification schemes. Clear defined criteria and indicators enable sustainability assessments to be made. Parametric 3D-building models provide the ideal starting point for analysis of buildings in terms of their sustainability with respect to many different aspects which can influence a buildings sustainability: energy consumption, operating efficiency, environmentally friendly building materials, flexibility of use, life cycle costs. This paper presents the results and challenges of a pre-project in the form of a tested workflow of a smart BIM-based rating system using an example from the Swiss Standard for Sustainable Building Switzerland (SNBS) and the international DGNB (Adapted for Switzerland) systems. Furthermore, a concept for a generic assessment platform is outlined which is able to convert the results of a parametric 3D-building model for use by the desired label and thus to attain the respective certification with much less effort.

#### Keywords:

Facility Management (FM); Sustainability Assessment Systems; Building Information Modelling/management (BIM); Planning and construction accompanying Facility Management (pcFM); Life Cycle Management (LCM)

## 1 INTRODUCTION

### 1.1 The need for proving sustainability

There is a global consensus that the built environment needs to create more sustainable buildings and minimize their impact on the environment. With increasing concerns regarding global warming this has become an urgent requirement. Sustainable buildings are vitally important not only from an environmental perspective. Research by [4], considered different studies which conclude that improving buildings' energy performance leads to economic savings up to 30% which means that energy efficiency, as a part of sustainability, is not only ecologically, but also profitable. Such research has led to many corporates and investors having a special interest in using and investing in sustainable buildings [3].

This resulted in the recent past in an increased demand for demonstrably sustainable buildings in Switzerland. Numerous investors reported to the

authors, that they have enough capital to invest in sustainable buildings, however they report the market for sustainable buildings is very limited. This meant that investors have begun increasingly to order sustainable buildings.

This led to two further questions: "How can investors order a sustainable building?" and "How can the designs be monitored and evaluated to prove the designs are achieving the desired level of sustainability and is it possible to incorporate optimization early during the planning phase?" The market shows that numerous sustainability rating systems are available. Which offer investors the opportunity to order the buildings to meet a specified sustainability quality level (e. g. DGNB Platinum). However, what is not so clearly established is a process that shows investors how they can understand the sustainability outcomes during the planning and construction phase and get involved continuously (e. g. in individual exemplary decisions). Through the

paradigm shift towards BIM new possibilities are opening up.

### 1.2 How BIM can help with sustainable building design

In short BIM is an integrated, software-based process which uses virtual representations of buildings and infrastructure etc. throughout the whole lifecycle [e. g. 8]. BIM has the potential to contribute to the design, construction and commissioning of buildings, helping to achieve lower environmental impacts. This could be through increased energy efficiency, reduced CO<sub>2</sub> emissions, less material consumption, or improved usability and optimising of the buildings by Facility Managers in the operational phase.

It is critical to understand BIM not just as a 3D-Tool but as a process which leads to enriched additional asset information and enables better and more accurate analysis and evaluations of the building to be carried out in the design phase. This might include daylighting and solar studies, material and product libraries containing embodied energy and Life Cycle Assessment (LCA) and Life Cycle Costing information, as well as deconstruction, maintenance and building management information for the entire lifecycle of a building. BIM allows stakeholders to understand how a building is constructed in great detail and to have a better grasp of how the building should perform and later, how it might be taken apart. To achieve this, the required specialist consultants' resources have to be shifted to earlier stages in the design process. Once evaluation, analysis and compliance tools with links to BIM are created, different design options could be more easily compared. This should lead to better informed decision making at early stages, reducing the risk of abortive design or the bolting on of 'eco-design features' (which are inherently less cost-effective) in later stages [7].

With BIM and these other tools, access to automatically calculated and current design data can be created which will be useful for environmental issues, such as heat-loss analysis calculating floor and surface areas and volumes, improved logistics, flexibility and optimization of support processes. For an optimal effect, the process should be formally integrated with Building Performance Evaluation (BPE), and Post Occupancy Evaluations (POE). A good example of such a process is the Soft Landings framework initiated by the UK Government [2].

In summary, there are many reasons for BIM to be incorporated in the sustainable planning of buildings. Since BIM maturity in many countries is still in early to middle stages of adoption and implementation [5], there are hardly any workflows and procedures established that enable the interaction between sustainable design, construction and operation with BIM.

## 2 BIM-CONCEPT FOR AN EFFICIENT IMPLEMENTATION OF THE EVALUATION OF SUSTAINABILITY

The significant opportunity of BIM for sustainability assessment is the ability to do it in a smart way. This means to keep any extra effort as low as possible and to use the technology to address the increasingly complex interrelationships and not to let them slip out of focus, which often happens with manual actions.

The concept required a workflow to be developed which makes it possible, to verify compliance with a certain sustainability level during the planning phase in an efficient way. The concept is based on the criteria in the SNBS [6] and uses the internationally recognized and adapted to Switzerland DGNB rating system (Label Holder Switzerland: Swiss Green Building Council SGNi) [9]. The process assessment of a sustainable building addresses the specific information requirements for digital 3D-building models. This information can then be used to estimate the creation effort (existing functionality) and estimated programming effort (new features) and their implementation within software tools like a BIM model checker.

Sets of rules are then created for all assessment criteria on which information can/should be contained in the BIM model attributes (e.g. for obstacle-free building design, which could of course be used independently of any sustainability labelling). With these rule sets digital 3D building models (via IFC export) can be analysed and evaluated with respect to the criteria of sustainability. This provides (intermediate) results which can be used to optimize the design and also improve the models themselves (e.g. information content). The actual evaluation of the sustainability performance of the proposed building is done in a separate, rating/certification platform. In this analysis, the results of the model checker can be imported and rated with the underlying standard of SNBS, or the Swiss DGNB rating system (available for different types of use; operationalized for Swiss standards). Based on this result on the one hand, the design of the building can be optimized efficiently in terms of desired Level of Sustainability by the client (second element of the evaluation results). On the other hand, the label can be awarded in a cost-effective manner (if desired). The following figure visualizes the solution:



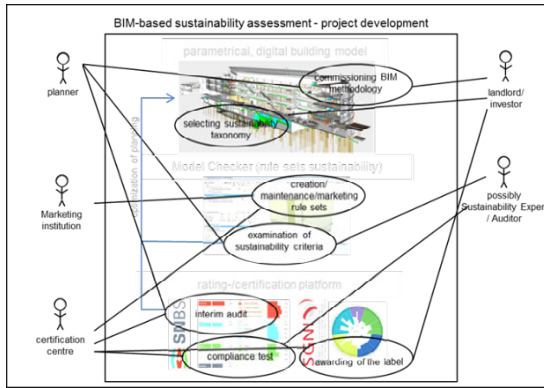

Fig. 1: BIM-based sustainability assessment - project development.

### 3 PRE-PROJECT FINDINGS AND RESULTS

#### 3.1 Creating a model for testing

For the first test of the concept the authors dispensed with a current, real project for this time. Thus the requirement of a BIM for testing the various sustainability criteria can be better controlled. According to the Conceptual Process Model [1] - BIM process for existing buildings – a 3D building model of an occupied building was created (use: education and office use; ca. 3'500 m<sup>2</sup> gross floor area) was created via Laser Scanning.

For the development of the model, appropriate criteria had to be established in advance which could be used with a model and the attributes for the exemplary sustainability impact assessment. The selected criteria were: "flexibility and conversion feasibility", "plan qualities" and "cleaning and maintenance friendliness of the building" (taken from the Swiss DGNB system).

#### 3.2 Selection of tools

Finding the right tools for testing the workflow required considerable effort. The selection process focused on choosing software with IFC interoperability in order to be independent of a particular BIM software platform.

Based on market research on the internet four model checking programs were finally selected. The result of the search and the properties of each product are shown in Table 1.

name of product	manufacturer	description	source
BIM Review Essentials	BIMreview	tool for controlling projects allowing participants; to visualize and check models e. g. collisions etc.	<a href="http://www.bim-review.com">www.bim-review.com</a>
Navisworks	Autodesk	Tool for engineers and architects; to compare federalistic organized models e.g. to check collisions and distribute results between participants	<a href="http://www.autodesk.com">www.autodesk.com</a>
Solibri Model Checker	Solibri	tool for all project participants; rules based testing and analysis; theoretically unlimited testing of model behavior	<a href="http://www.solibri.com">www.solibri.com</a>
Tekla BIMsight	Tekla	for engineers and architects; to compare federalistic organized models e.g. to check collisions and distribute results between participants	<a href="http://www.teklabimsight.com">www.teklabimsight.com</a>

Tab. 1: market survey model checker (extraction).

Each tool was assessed and in order to evaluate the programs on the shortlist for their suitability for the sustainability impact assessment. The Solibri Model Checker was selected as the most appropriate software to consider mainly because of its capability to work with rule sets [10], which provides several options for model testing and data export.

Within this test phase the requirements for data import and results were formulated coming from the model testing. The programming of the rating/certification platform will be part of an upcoming R&D project at the IFM.

#### 3.3 Testing the workflow

Using the example of the criteria "flexibility and conversion capacity" (Swiss DGNB System) seven indicators have to be analysed in more detail: area efficiency, height of ceilings, building depth, vertical access, floor plan distribution, construction and technical building equipment. Each indicator is based on geometric values of the building. The check carried out by the Model Checker provided excellent results and even allowed playing back the results achieved in accordance with the evaluation system for use in the planning process. The Model Checker provides good support to the achievement of sustainability goals. However, due to missing sub-models the criteria "building equipment" and the "quality of use areas" could not be fully tested.

During the test, the three selected evaluation criteria (see 3.1) were found that the results of the sustainability assessment stand or fall with the quality of parametric 3D building models. Is the model, for example, not built storey by storey and each plot well drawn and attributed, no testing was possible [11].

### 4 CONCLUSIONS

Looking at the sustainability evaluation systems, it is clear that not all criteria are available out of a BIM-(workflow), as we know it today. This means that the rating/certification platform has to have the capability to read the rest of the information from other sources, otherwise input by hand is necessary. While single criteria/indicators of sustainability rating systems (preferably geometry-based) can be examined and evaluated in an efficient way from a BIM model, many criteria can be evaluated not only by using BIM. To do so other tools have to be developed, e. g. a rating-/certification platform, which could create the achieved label as a by-product.

In order to realize in the future an efficient and meaningful BIM-based sustainability assessment, a requirement profile of the building model needs to be defined as a standard, so that the necessary tools can be specifically designed to make the assessments.

The next research and project steps are:

- create a catalogue of information requirements for sustainable construction of the desired standard, interpreted for implementation in BIM (e. g. Level of Development, LOD)
- define the flow of information between different systems (e.g. BIM software such as Vectorworks, ArchiCAD, Revit, Solibri model checker and the certification platforms)
- extend the model checker (new rule functions)
- create rule sets, which are formed according to Swiss standards and guidelines (e.g. obstacle-free building); which can then be used in any (BIM) – project, regardless of sustainability certification
- programming of an application for assessing the sustainability of buildings based on established certification systems (possibly SNBS, Swiss DGNB, LEED, BREEAM etc.)

## 5 ACKNOWLEDGMENTS

A special thanks goes to Christoph Kuster (Computer Works AG, Münchenstein) for providing a temporary license of Solibri ModelChecker and to Martin Wyss (MSc Student at IFM – ZHAW) for testing the software.

## 6 REFERENCES

1. Ashworth, S. & Druhmman, C. (2015). Integration of FM and asset management expertise in digital 3D building models. In: *Journal für Facility Management: Wissenschaft trifft Praxis*, 10, Vienna 2015, pp. 38-52.
2. BIM Task Group. BIM Task Group . [4. August 2014]. WWW: <http://www.bimtaskgroup.org>
3. CSR. CSR SUSTAINABILITY REPORT 2013 [online]. CSR Limited, 2013, [cit. 2015-11-25]. WWW: [http://www.csr.com.au/Community-and-Sustainability/Sustainability/Documents/SustainabilityReport2013\\_Full.pdf](http://www.csr.com.au/Community-and-Sustainability/Sustainability/Documents/SustainabilityReport2013_Full.pdf)
4. Dorta, N., Assef, P., Cantero, J. & Rufino, G. Implementing BIM techniques for energy analysis: A case study of buildings at University of La Laguna. *Environmental Security, Geological Hazards and Management*, 2013. Spain. pp. 61-67.
5. Kassem, M., Succar, B., & Dawood, N. Building Information Modeling: analyzing noteworthy publications of eight countries using a knowledge content taxonomy. In: R. Issa & S. Olbina (Eds.), *Building Information Modeling: applications and practices in the AEC industry*, ASCE Technical Council on Computing and IT. University of Florida, 2013.
6. NNBS. Sustainable Construction Network Switzerland. Bern, 2015. [01.12.2015]. WWW: [www.nnbs.ch](http://www.nnbs.ch)
7. Pelsmakers, S. BIM and its potential to support sustainable building. RIBA Enterprises Ltd, 2013. [cit. 2015-11-25] WWW: <http://www.thenbs.com/topics/bim/articles/bimPotentialSupportSustainableBuilding.asp>
8. Pellekoorne, P.-G. Analyse der BIM-Software Autodesk Revit 2013 anhand der Modellierung eines Gebäudes der Technischen Universität München. Munich 2012.
9. SGNI. Schweizer Gesellschaft für nachhaltige Immobilienwirtschaft – Swiss Green Building Council. Zurich, 2015. [03.12.2015]. WWW: [www.sgni.ch](http://www.sgni.ch)
10. Solibri Inc. (2015). Solibri. Abgerufen am 03. 06 2015 von <http://www.solibri.com/de/1>.
11. Wyss, M. (2015). Effiziente Nachhaltigkeitsbewertung in BIM-basierten Planungs- und Bauprozessen. [Unpublished Bachelor's thesis]. Institute for Facility Management ZHAW, Zurich Switzerland.



## Expanding Boundaries: Systems Thinking for the Built Environment

### THE CITY ENERGY ANALYST TOOLBOX V0.1

Jimeno A. Fonseca<sup>1,2\*</sup>, Daren Thomas<sup>2</sup>, Anja Willmann<sup>2</sup>, Amr Elesawy<sup>2</sup>,  
Arno Schlueter<sup>1,2</sup>

<sup>1</sup>ETH Zurich, Future Cities Laboratory, Singapore-ETH Center. 1 Create Way, 138602, Singapore

<sup>2</sup>ETH Zurich, Architecture and Building Systems. John-Von-Neumann-Weg 9,8093, Zürich

\*Corresponding author; e-mail: [fonseca@arch.ethz.ch](mailto:fonseca@arch.ethz.ch)

#### Abstract

The City Energy Analyst is a novel computational framework for the analysis of building energy systems at neighbourhood and district scales. The framework serves to define strategies that minimize the overall energy intensity, carbon footprint and annualized costs of energy services in urban areas. This paper presents the integration of two modules of this framework into an open-source extension for ArcGIS: The City Energy Analyst Toolbox V0.1. This article discusses an exemplary application of such a toolbox in education. The tool allowed master students in engineering to define the environmental impact of buildings in an urban area and learn about alternatives to ameliorate this. In the future, the tool could support urban designers and energy systems engineers to jointly increase the energy efficiency of urban settlements.

#### Keywords:

Urban energy systems simulation; parametric urban design; IT in education

## 1 INTRODUCTION

The City Energy Analyst (CEA) is a framework for the analysis of building energy systems at neighbourhood and district scales. The framework serves to define energy efficiency strategies that minimize the energy intensity, carbon footprint and annualized costs of energy services in urban areas [1]. The framework has been used in building performance assessments (e.g. [2]), energy systems optimizations (e.g. [1], [3], [4]) and life cycle and resilience assessments (e.g. [5], [6]).

This paper presents the integration of two modules of this framework into an open-source extension for ArcGIS V10.3: The City Energy Analyst Toolbox (CEA Toolbox) V0.1.

Section 2 introduces the components of the framework and the CEA Toolbox. Section 3 introduces an exemplary application in education. Section 4 discusses advantages and constraints of the tool in urban and energy planning practice.

## 2 METHODOLOGY

The CEA Toolbox V0.1 integrates modules one and five of the City Energy Analyst framework (Fig. 1) into the ArcGIS ArcScene software. The first is a building energy demand model. The second is an algorithm for life cycle assessment (LCA) of buildings and infrastructure. Seven databases group all input variables (see Table 1 in the Appendix).

By integrating with ArcGIS, the CEA Toolbox leverages a GIS environment and blends the workflow of the user with the wealth of tools provided by ArcGIS. This facilitates users to link their analysis to other features of the context (e.g. land use, landownership, greenery). For those features, ArcGIS provides a wide set of analysis tools.

The CEA Toolbox wraps the CEA modules into tools defined in an ArcGIS Python toolbox. Each tool provides a dialog for the input parameters and hands these parameters over to the CEA modules for calculation.

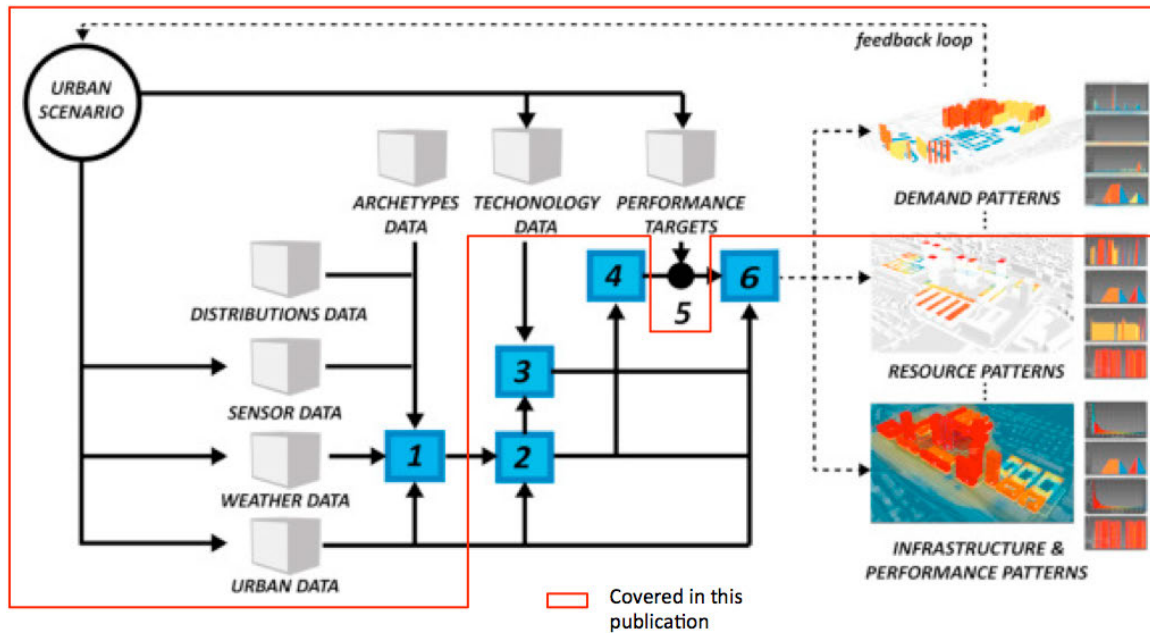

Fig. 1: Overview of the CEA framework: Databases, Modules, and Workflow. 1. Demand module, 2. Resource potential module, 3. Systems technology module, 4. Systems optimization module, 5. Decision module, 6. Spatiotemporal analysis module (extracted from Fonseca et al. [1]).

Fig. 2 shows the various components of the graphical user interface. The Catalog Panel provides access to connected folders, containing GIS data and results from the computations. The Visualization Panel is the main view in ArcScene. It shows the CEA results projected onto the geometry of the urban landscape. The Layer Panel lists the layers displayed in the Visualization Panel. The user can toggle each layer on and off depending on the current visualization needs. The Attributes Panel shows the properties of a layer in a tabular view. The user can use the Attributes Panel to adjust the properties of buildings. The Toolbox Panel contains a list of tools registered with ArcGIS, including the CEA Toolbox.

The tools provided in the CEA Toolbox are Properties, Demand, Embodied Energy, Emissions, and Heatmaps.

The Properties tool initializes the properties of the Buildings layer using the archetypes of [2].

The Demand tool calculates the hourly demand of energy services in buildings according to [2].

The Embodied Energy tool calculates the embodied energy and gray emissions of buildings according to [7].

The Emissions tool calculates the primary energy consumption and greenhouse gas emissions of buildings according to [2].

The Heat-maps tool calculates heat maps from the output of the above tools using the ArcGIS Hot Spot Analysis tool.

The CEA Toolbox is published under the open source MIT License [8] on GitHub [9].

### 3 RESULTS

Eight master students in Integrated Building Systems evaluated a potential energy system for the “Hochschulquartier” in Zurich for 2030. The energy system had to achieve the benchmarks of the 2000-Watt Society [10]. This academic exercise had three phases (Fig. 3):

#### Phase I: Status Quo Analysis

This phase defines the boundary conditions for potential retrofits to infrastructure and buildings. It consists of data collection, simulation of the existing setting and potential analysis. The data collection task gathers the parameters of Table 1 from official documents, maps, questionnaires and on-site surveys. The CEA Toolbox is used to compute the carbon footprint and energy intensity of the area (Fig. 3a), and to identify low-performing buildings (Fig. 3b).

The potential analysis (Fig. 3c) uncovers opportunities (e.g., distributed generation and building retrofit opportunities) and constraints (e.g. building preservation) to increase the energy efficiency of the area.

#### Phase II: Scenarios development

This phase comprises the development of urban design scenarios. Each scenario is described by modifications to the variables of Table 1.

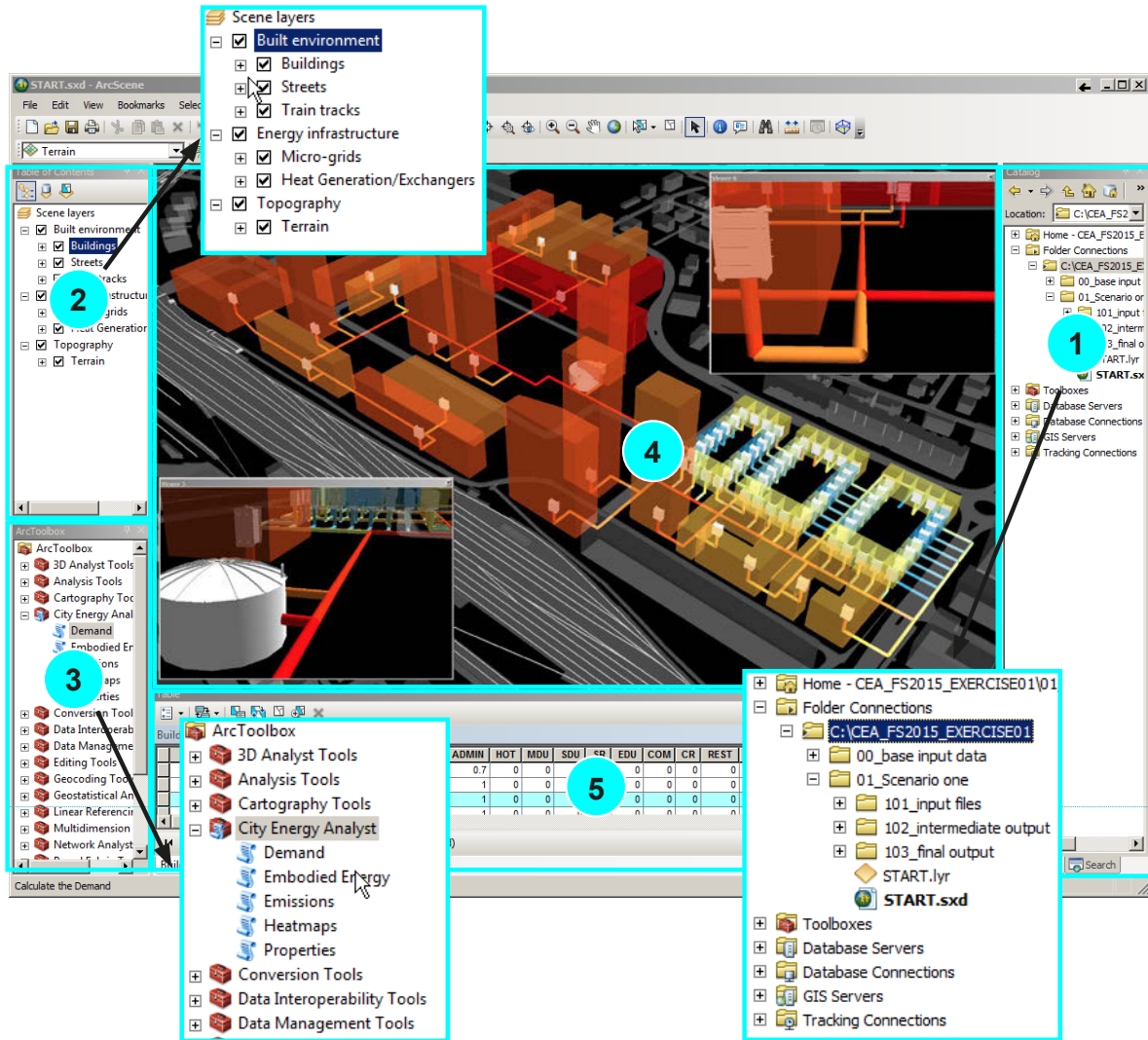

Fig. 2: Graphical user interface, 1. Catalog Panel, 2. Layer Panel, 3. Toolbox Panel, 4. Visualization Panel, 5. Attributes Panel.

The CEA Toolbox is used to calculate the energy demand of the scenarios. The results are then evaluated against the opportunities to increase the efficiency of the area (Phase I). A comparison phase follows, which determines the most fitting strategy for the intervention. This strategy needs to comply with the carbon and energy limits of the 2000-Watt Society [10]. This phase determines the need for a new iteration. Fig. 3d presents an example of this process.

### Phase III: Energy Systems Proposal

After evaluation, the energy system of the area is depicted in three diagrams: an urban energy systems diagram (Fig. 3e), a 3D map (Fig. 3f), and a Sankey diagram (Fig. 3g). The urban energy systems diagram describes the components and interconnectivity rules of the system. The Sankey diagram describes the yearly balance of energy flows per end-use. The map describes the location of every infrastructure component.

## 4 DISCUSSION AND CONCLUSIONS

The CEA Toolbox allows users to estimate the performance of an urban energy system. Moreover, it helps users to identify the spatial relation between urban design and energy systems decisions. From the teaching perspective, the use of such a low-barrier tool facilitates an intuitive access to urban energy interactions for entry-level experts.

The first version (V0.1) of the CEA Toolbox presents a series of limitations in terms of model accuracy, user experience and concept of operations.

Based on data of [1] and [2], the demand module of the CEA Toolbox has a mean error of 32% at the building scale and 5% at neighborhood scale ( $n=24$ ). Future work to decrease this error might lie on calibration with sensor data and implementation of more advanced models for air ventilation and occupancy.

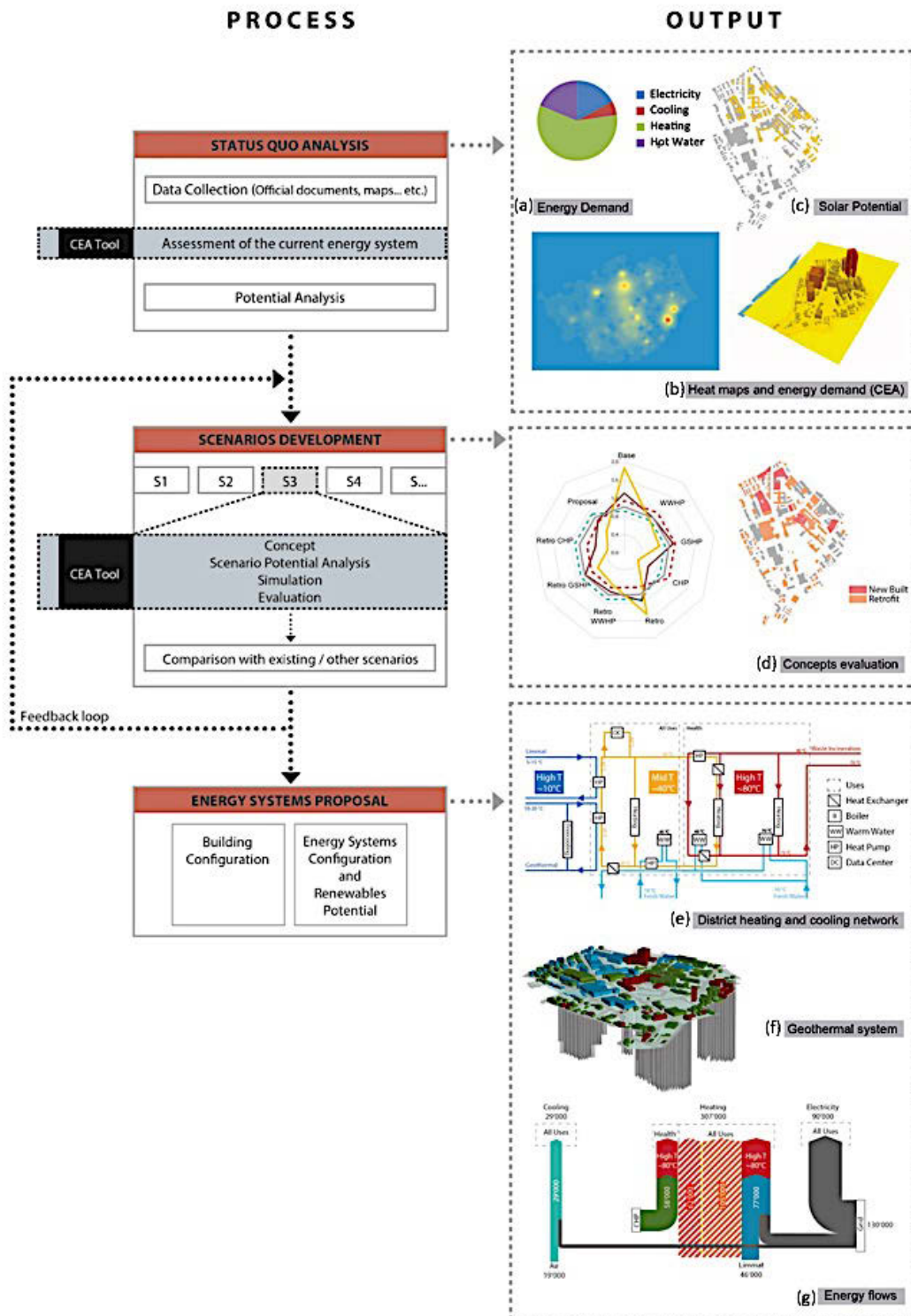

Fig. 3: Process overview and output examples.

The CEA toolbox V0.1 provides a limited analysis of alternatives for energy generation. It does not consider the economics and technical restrictions of infrastructure during design and operation. The future implementation of the remaining models of the CEA framework should address this limitation.

The toolbox presents low levels of automation about reporting and generation of multiple

scenarios. A cloud-based architecture would facilitate the real-time evaluation of scenarios. Such a feature has been one of the key advantages of other low-barrier tools in sustainable architecture (e.g. [11], [12]). Future tests with urban designers and energy systems engineers would help to identify other features that improve user experience.

Practitioners could find the CEA Toolbox useful to forecast the performance of an urban energy system and link the results to other features of the context in a GIS interface. A new concept of operations could allow users to integrate urban design and energy systems planning in their current practices. This aspect could require professionals with knowledge in both areas.

## 5 ACKNOWLEDGMENTS

The authors thank Moritz Begle for his teaching support. Thanks are also due to students of the Master's program in Integrated Building Systems (MBS) at ETH Zurich, who attended the course on integrated design in the fall semester of 2015: Julia Brey, Stefan Caranovic, Marc Lallemand, Jonas Landolt, Randi Nanayakkara, Paul Neitzel, Yasmine Priore and Yueqiu Wang.

## 6 REFERENCES

1. J. A. Fonseca, T.-A. Nguyen, A. Schlueter, and F. Marechal, "City Energy Analyst (CEA): Integrated framework for analysis and optimization of building energy systems in neighborhoods and city districts," *Energy Build.*, vol. 113, pp. 202–226, Feb. 2016.
2. J. A. Fonseca and A. Schlueter, "Integrated model for characterization of spatiotemporal building energy consumption patterns in neighborhoods and city districts," *Appl. Energy*, vol. 142, pp. 247–265, 2015.
3. T. Vollrath, "Local micro-grids for low-carbon building systems," ETH Zurich, 2015.
4. T.-A. Nguyen, "Optimization of a District Energy System in the context of Urban Transformation," ETH Zurich, 2015.
5. J. A. Fonseca, A. Willmann, C. Moser, M. Stauffacher, and A. Schlueter, "Assessing the environmental impact of future urban developments at neighborhood scale," in *Proceedings of CISBAT 2015*, 2015, p. 6.
6. J. A. Fonseca and A. Schlueter, "Assessing the performance and resilience of future development at neighborhood scale," in *SBE 2016, Expanding Boundaries: Systems Thinking for the Built Environment*, 2016, p. 5.
7. E. Thoma, J. A. Fonseca, and A. Schlueter, "Estimation of base-values for Grey Energy, Primary Energy, Global Warming Potential (GWP 100A) and Umweltbelastungspunkte (UBP 2006) for Swiss constructions from before 1920 until today," in *Contemporary Urban Issues '14*, 2014, no. Ubp, p. 17.
8. Open Source Initiative, "MIT License," *Software Licenses*, 2016. [Online]. Available: <https://opensource.org/licenses/MIT>. [Accessed: 26-Jan-2016].
9. Architecture and Building Systems, Institute of Technology in Architecture, and ETH Zurich, "The CEA Toolbox V0.1," *Repository*, 2016. [Online]. Available: <https://github.com/architecture-building-systems/CEAforArcGIS>.
10. D. Kellenberger, M. Ménard, S. Schneider, M. Hänger, M. Org, K. Victor, and S. Lenel, *Arealentwicklung für die 2000-Watt-Gesellschaft: Beurteilungsmethode in Anlehnung an den SIA-Effizienzpfad Energie*. Bern: Bundesamt für Energie, 2012.
11. Sefaira Ltd., "Sefaira Architecture." Sefaira, London, GB, p. 1, 2015.
12. A. Schlueter and F. Thesseling, "Building information model based energy/exergy performance assessment in early design stages," *Autom. Constr.*, vol. 18, no. 2, pp. 153–163, Mar. 2009.

## 7 APPENDIX

Database	Variable	Format	Variable	Format
Weather data	Ambient temperature Relative Humidity	.csv .csv	Solar transmissivity.	csv
Urban data	Buildings: Footprint area Roof inclination Height Window-to-wall-ratio Shading system HVAC system Generation technology type Occupancy type Construction year Renovation year	.shp .shp .shp .shp .shp .shp .shp .shp .shp .shp	Environment: Streets layout* Sewer layout* Power network layout 3D Topography Water body layout* Soil strata*	.shp .shp .shp .tiff .shp .shp
Archetypes data	HVAC: Type Operating temperatures	.csv .csv	Envelope: Thermal mass type Thermal transmittance	.csv .csv
Distribution data	Occupancy: Schedules Minimum ventilation rates Temperature set-point	.csv .csv .csv	Humidity set-point Fresh water requirements Hot water requirements	.csv .csv .csv
Sensor database	Measured variables in any other database.*	.csv or .shp	Context specific hourly end-use demands (e.g. industrial processes)*	.csv
Technology database	Primary energy factors. CO <sub>2</sub> -eq factors.	.shp .shp	Costs.*	.csv
Performance targets data	Grey emissions per building component area.* Embodied energy per building component area.*	.xls .xls	Local standard Minergie* 2000-watt society standard	.xls

Table 1: Databases and variables of the CEA framework. \*variables not integrated into the CEA Toolbox V0.1.





## Expanding Boundaries: Systems Thinking for the Built Environment

### A METHOD FOR EVALUATING THE ENVIRONMENTAL LIFE CYCLE POTENTIAL OF BUILDING GEOMETRY

A. Hollberg<sup>1\*</sup>, N. Klüber<sup>2</sup>, S. Schneider<sup>1</sup>, J. Ruth<sup>1</sup>, D. Donath<sup>1</sup>

<sup>1</sup> Bauhaus-Universität Weimar, Belvederer Allee 1, 99425 Weimar, Germany

<sup>2</sup> Fraunhofer Institute for Mechanics of Materials, Walter-Hülse-Straße 1, 06120 Halle, Germany

\*Corresponding author; e-mail: alexander.hollberg@uni-weimar.de

#### Abstract

Life Cycle Assessment (LCA) is becoming more and more important for building sustainability evaluation. However, in architectural practice LCA is not carried out in early design stages although the consideration of the environmental life cycle performance (LCP) is essential for creating sustainable buildings and early design stages offer the highest potential for optimization. The main focus in these design stages lies on the definition of the building geometry. However, conducting an LCA only based on building geometry is impossible due to missing information about materials and HVAC systems. Therefore, in this paper we propose a method for assessing the potential LCP (PLCP) that a building geometry offers. PLCP describes the probability of a specific building geometry to achieve a certain LCP in later design stages. This measure can serve to optimize designs according to life cycle aspects. The application of the method is exemplified for the evaluation of six geometric variants of a residential building. The results indicate that PLCP is a valuable measure for decision-making in the architectural design process.

#### Keywords:

Life Cycle Assessment (LCA), environmental life cycle performance, architectural design, design space exploration

## 1 INTRODUCTION

Life Cycle Assessment (LCA) is becoming more and more important for building evaluation in the scientific context [1] and in architectural practice – mostly in the form of building certification labels, e.g. DGNB [2] and BNB [3]. In those cases the LCA is used at a late stage of the design to evaluate the environmental impact and fulfil the requirements of the certification label. However, only evaluating the building design through LCA is not sufficient on its own if the results are not used to improve the design [4].

In order to minimize environmental impacts, an optimization is needed. In general, optimization of the design can best be achieved in early design stages, because decisions made in those stages have the biggest influence on energy demand [5] and environmental impact [6] while showing the smallest costs for changes to the design [7].

Usually, the architectural design process begins with geometric variants for the building shape and finally defining the geometry of the building. However, the most fundamental decisions, considering the geometry of the building, e.g. shape, orientation, window layout, are made with little or no involvement of simulation software [8]. A measure for the environmental performance of the building during the whole life cycle, which in the following is referred to as life cycle performance (LCP), would be valuable to provide a basis for deciding between geometric variants.

When conducting LCA in early design stages numerous challenges arise. In this paper, we address three main challenges:

- (i) In contrast to well-defined problems with an apparent goal and end, architectural design problems are ill-defined where both the end and the means for a solution are unknown [9]. Subsequently,

many alternative solutions exist and design becomes a process of selecting amongst them.

- (ii) The numerous design parameters, such as geometry, materials and HVAC systems influence each other, making a separate optimization impractical.
- (iii) Information necessary for LCA including specific data on the building materials and HVAC systems is usually not available in conceptual design stages. Once this information is available in later design stages, changes based on LCA results are hard to implement, because they would induce high costs and effort.

To address these challenges, we propose to combine a method for multi-stage design space exploration [10] with a parametric LCA method described in [11], [12], which can easily generate variants as basis for optimization. The proposed approach is exemplified using a case study of a residential building. The aim is to evaluate the potential life cycle performance (PLCP) of different geometric variants in the conceptual design stage in order to help the designer decide which geometry to choose for further planning stages.

## 2 METHODS

The design process is regarded as a search process, whereby variants are generated, evaluated, selected and improved in an iterative manner [13]. Rittel [10] describes several ways to search for solutions (explore the solution space). These range from a linear approach, where no alternatives are created (Fig. 1a); to a single stage variant-selection approach, where for each aspect of a design variants are created, the best is chosen, and from there other aspects are considered (Fig. 1b); to a multi-stage approach, where for each aspect all variants are considered (Fig. 1c).

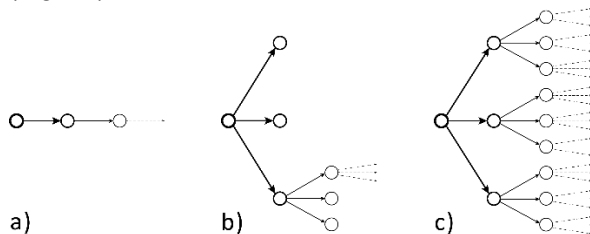

Fig. 1: Linear process (a), single-stage variant selection (b) and multi-stage variant selection (c), based on [10].

This last strategy can, for example, consist of the following steps: first, three variants for the shape of the building are created; second, three floor plans are created for each of them; third, several window layouts are created for each of the floor plans; fourth, building materials are chosen for each of these variants and finally HVAC systems

are selected (of course the order in which these aspects are processed may vary).

This strategy is the most beneficial in order to not miss out potentially good solutions. However, this is also the most time-consuming one, due to the immense number of combinations that are possible. Thus, parts of this process need to be automated, because a designer is not able to manually create and evaluate all variants.

We assume that variants of the building geometry are created in the very early branching phases of the decision tree shown in Figure 1c. The method aims for estimating the PLCP that a building geometry offers, regardless of additional information on materials or HVAC systems. Therefore, the process of creating variants for materials and HVAC is simulated. The LCP is calculated for all resulting possible combinations. The range of LCP a building geometry achieves is used to characterise the PLCP.

To quickly calculate the LCP, a previously developed LCA method is used [11]. This method divides all necessary input into three categories, namely geometric information, non-geometric information and surrounding conditions. All input in those categories is defined parametrically, permitting quick adaption and variation. To facilitate the input of the geometry, a simple 3D CAD model consisting only of surfaces is employed. The surface areas are extracted automatically. The thicknesses of building components, material properties and other non-geometric parameters are defined numerically. Surrounding conditions, such as climate or user data, are taken from standards.

To carry out a building LCA, three kinds of material data are necessary: environmental data, reference service life (RSL) data and physical properties. Environmental data based on ökobau.dat version 2011 [14] and typical values for the RSL are chosen according to [15] and DGNB [2]. Physical properties such as thermal conductivity are taken from DIN 4108-4 [16].

A catalogue of the most common building components is established to reduce the effort of data input. The level of detail corresponds to the simplified input of materials as recommended by DGNB [2]. All components which are part of the thermal building envelope (exterior wall, roof, slab/basement ceiling) are defined using two layers. Layer A consists of all materials with predefined thicknesses except the insulation material. Layer B consists of the insulation material with a variable thickness in order to adapt the u-value of the component. Other building components are defined only using one fixed layer A.

It is distinguished between operational impact ( $I_O$ ), which consists of life cycle module B6 according to EN 15987 [17] and embodied impact ( $I_E$ ) which consists of modules A1-A3, B4, C3,

C4, and D. Both are calculated separately and then added together to provide the life cycle impact ( $I_{LC}$ ), see Eq.1. The operational impact consists of the sum of all different kinds of energy demand during the use phase ( $ED_i$ ) divided by a performance factor ( $PF_i$ ) for the specific building services, multiplied by the impact factor of the energy carrier ( $IF_{O,i}$ ), and multiplied by the number of years of the reference service period (RSP), see Eq.2. The embodied impact of one material is calculated by multiplying the mass ( $M_j$ ) by the specific impact factor of the material ( $IF_{E,j}$ ) and by the number of replacements ( $R_j$ ), see Eq.3. In this way, the embodied impact of every component is calculated and summed up to the embodied impact of the complete building.

$$I_{LC} = I_O + I_E \quad (1)$$

$$I_O = \sum_i (ED_i / PF_i \times IF_{O,i}) \times RSP \quad (2)$$

$$I_E = \sum_j (M_j \times IF_{E,j} \times (1 + R_j)) \quad (3)$$

To apply this parametric LCA method it has been implemented in a parametric design software called Grasshopper3D (GH) [18]. Both, the calculation of energy demand and embodied impact are fully integrated into GH, making exporting and re-importing unnecessary. We implemented DIN V 18599-2:2011 [19] in GH for the energy demand calculation and the implementation has been verified for residential buildings [20]. The developed parametric LCA tool is able to provide results in real time (< 0.1 s).

The results are reported for the indicators defined in EN 15987 [17]. According to ISO 14040 [21] weighting steps are based on value-choices and not scientifically based. Kägi et al. [22] report that decision makers always have to aggregate the LCA results in order to make a decision on it. They furthermore discuss that it might be better to provide a single score for decision makers instead of letting them make the weighting on their own. The parametric LCA tool allows the advanced user to define and adapt own weighting factors in order to consider individual goals of the LCA study. Furthermore, it allows to employ different predefined weighting factors, e.g. those of building certification systems. For the calculation of LCP in this paper, we implemented the calculation of evaluation points (Bewertungspunkte, BP) of DGNB for both criteria related to LCA, namely ENV 1.1 and 2.1. These are weighted according to the DGNB system for residential buildings and combined into one value, which is called weighted BP (WBP) here.

To provide an example of application we present a case study of the design optimization of a new residential building in the following. The aim is to find the PLCP of six different geometric building

typologies. Furthermore, it is investigated to which degree the geometry determines the LCP.

### 3 CASE STUDY

The building to be designed should provide eight apartments with a gross floor area (GFA) of 150 m<sup>2</sup> each. Six geometric variants are compared, each representing one typical type of residential building. To cover a wide span of geometries the variants range from detached houses to an apartment tower. For each geometric variant we assume six different kinds of heating systems and six combinations of typical building materials. Furthermore, three different u-values of the thermal building envelope representing different levels of energy standards are used to generate material variants. This results in 108 possible variants for each of the six building types.

The geometry for each building type is modelled in Rhinoceros [23], while all other necessary data is input in GH. Screenshots of the types and the variants for heating systems (H), building materials (M), and u-values (U) are provided in Table 1. Furthermore, we made the following assumptions:

- The functional unit is the usage of 1 m<sup>2</sup> net floor area (NFA) for 1 year.
- The NFA equals 0.8 × GFA.
- The RSP is 50 years.
- The buildings are located in a suburban context without shading from neighbouring buildings in Potsdam, Germany.
- The storey height is 3 m.
- The buildings do not have basements.
- The window area is 1/8 of the NFA of each storey, which is in line with the minimum requirement according to German state building regulations [24].
- The ventilation occurs naturally.
- The electricity demand is 20 kWh/m<sup>2</sup>a.

### 4 RESULTS AND DISCUSSION

All 648 possible variants have been calculated in a loop, which took less than 70 seconds showing the time-efficiency of the parametric LCA tool. The WBP that each of the six typologies achieved have been exported to Excel. To display the results, the WBP have been normalized to the maximum which can be achieved. To visualize the range of results, we use a boxplot, see Figure 2.

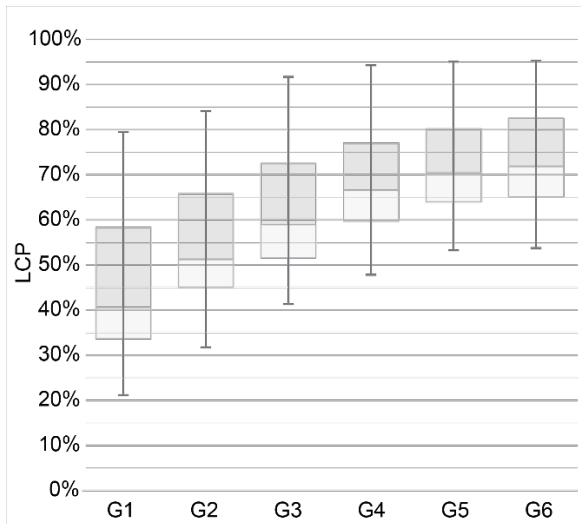

Fig. 2: Boxplot showing the range of LCP for each building geometry.

The boxplot indicates three main aspects: First, the ends of the vertical line (whisker) indicate the maximum and minimum LCP that can be achieved by a geometric variant. Second, the horizontal line within the box marks the median of all analysed solutions. As such, it indicates the LCP that is reached with a probability of 50%. Finally, the ends of the box indicate the first and third quartile which means that 50% of the possible solutions possess an LCP within the range of the box. The length of the whisker and the size of the box show to which degree the geometry determines the LCP that can be achieved. The designer can use this information for deciding which geometric variant should be pursued in the following detailed design stages.

The results can also be used to show to which degree the other parameters (H, M, and U) determine the LCP. To analyse the influence of one category on the PLCP, parameters from other categories have been fixed.

Figure 3 shows the PLCP for three heating systems (H6, H4, and H1) in dependence of the geometric variants. The heating systems represent the environmentally best (H6) and worst solution (H1) and an average solution (H4). The combination of building materials and the u-value have been fixed (M1 and U2). The results indicate that a relatively large range of LCP can be achieved through variation of the heating system. However, the best heating system (H6) only reaches the third quartile of all possible solutions. Even for the best geometric variant (G6) only about 80% of the maximum LCP can be achieved.

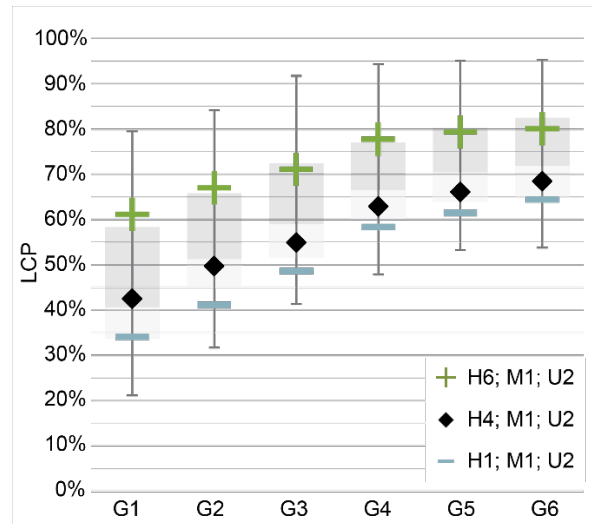

Fig. 3: LCP for three heating systems with fixed material and u-value.

The influence of the choice of building materials on the PLCP can be investigated likewise. Figure 4 shows the results for three combinations of materials (M1, M4 and M5) with a fixed heating system of average performance (H4) and a high-level u-value (U2). M1 lies close to the median for all geometric variants. The environmentally worst material variant (M5) lies just under M1. The environmental advantages of wooden constructions are reflected by the LCP of M4 which reaches between 79.5 and 94.5% of the maximum LCP in combination with H4 and U2.

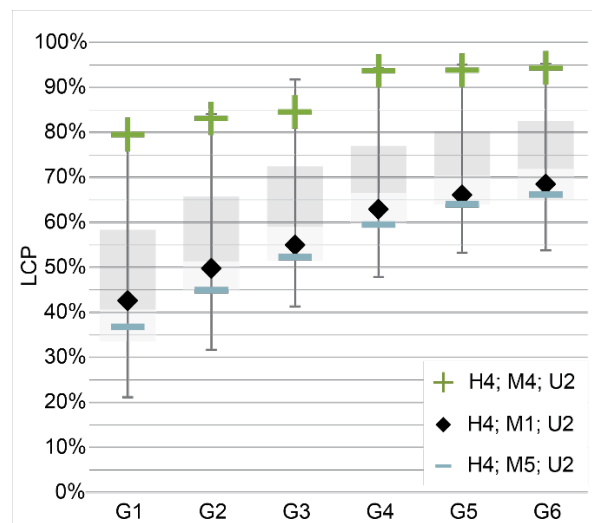

Fig. 4: LCP for three combinations of building materials with fixed heating system and u-value.

## 5 CONCLUSIONS

When aiming for a high LCP during the design of a building, ideally a multi-stage design space exploration would be carried out. However, this is difficult in practice, due to the high effort this approach involves and the missing information in early design stages. Therefore, we proposed a method that calculates a range of plausible solutions in each step based on assumptions for

HVAC systems, building materials, and energy standards of the building envelope. The results provided a forecast of the LCP that can potentially be achieved later. As such, the method can be used to identify building geometries with a high PLCP. This helps the designer to choose a geometry for further planning stages.







Ideally speaking, this method frees the designer from worrying about HVAC systems and building materials in early design stages and allows to focus on the geometry. The PLCP approach integrates information of HVAC systems and building materials in the geometry. Using this measure the designer can optimize the geometry without having information usually required for an LCA. As such it provides a solution to the challenges mentioned in the introduction.

## 6 ACKNOWLEDGMENTS

This study was carried out as part of the research project 'Integrated Life Cycle Optimization' funded by the German Federal Ministry for the Environment, Nature Conservation, Building and Nuclear Safety through the research initiative ZukunftBau.

## 7 REFERENCES

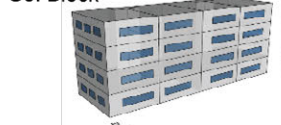
1. M. Weißenberger, W. Jensch, and W. Lang, "The convergence of life cycle assessment and nearly zero-energy buildings: The case of Germany," *Energy Build.*, vol. 76, pp. 551–557, 2014.
2. DGNB, "DGNB system," 2015. <http://www.dgnb-system.de/en/>. [Accessed: 04-Apr-2015].
3. BBSR, "BNB system," 2015. <https://www.bnb-nachhaltigesbauen.de/bewertungssystem/bnb-bewertungsmethodik.html>. [Accessed: 04-Apr-2015].
4. B. Wittstock, S. Albrecht, C. Makishi Colodel, J. P. Lindner, G. Hauser, and K. Sedlbauer, "Gebäude aus Lebenszyklusperspektive – Ökobilanzen im Bauwesen," *Bauphysik*, vol. 31, 2009.
5. M. Hegger, M. Fuchs, T. Stark, and M. Zeumer, *Energie Atlas: Nachhaltige Architektur*. Birkhäuser, 2007.
6. C. Schneider, *Steuerung der Nachhaltigkeit im Planungs- und Realisierungsprozess von Büro- und Verwaltungsgebäuden*. 2011.
7. B. C. Paulson Jr., "Designing to Reduce Construction Costs," *J. Constr. Div.*, vol. 102, no. 4, pp. 587–592, 1976.
8. M. Picco, R. Lollini, and M. Marengo, "Towards energy performance evaluation in early stage building design: A simplification methodology for commercial building models," *Energy Build.*, vol. 76, pp. 497–505, Jun. 2014.
9. P. G. Rowe, *Design Thinking*. MIT Press, 1987.
10. H. Rittel, "Der Planungsprozess als iterativer Vorgang von Varietätserzeugung und Varietätseinschränkung," *Arbeitsberichte zur Planungsmethodik* 4, pp. 17–31, 1970.
11. A. Hollberg and J. Ruth, "A Parametric Life Cycle Assessment Model for Facade Optimization," in *Conference Proceedings of Building Simulation and Optimization*, 2014.
12. N. Klüber, A. Hollberg, and J. Ruth, "Life cycle optimized application of renewable raw materials for retrofitting measures," in *World Sustainable Building Conference, Barcelona, Conference Proceedings Session 106*, 2014.
13. A. Newell and H. A. Simon, *Human problem solving*. Prentice-Hall, 1972.
14. BBSR, "ökobau.dat." Bundesministerium für Umwelt, Naturschutz, Bau und Reaktorsicherheit, 2011.
15. BBSR, "Nutzungsdauern von Bauteilen für Lebenszyklusanalysen nach Bewertungssystem Nachhaltiges Bauen," 2011.
16. DIN 4108-4:2013 *Wärmeschutz und Energie-Einsparung in Gebäuden – Teil 4: Wärme- und feuchteschutztechnische Bemessungswerte*.
17. EN 15978:2012 *Nachhaltigkeit von Bauwerken – Bewertung der umweltbezogenen Qualität von Gebäuden*.
18. D. Rutten, "Grasshopper3D," 2015. <http://www.grasshopper3d.com/>. [Accessed: 11-Nov-2015].
19. DIN V 18599-2:2011 *Energetische Bewertung von Gebäuden - Berechnung des Nutz-, End- und Primärenergiebedarfs für Heizung, Kühlung, Lüftung, Trinkwasser und Beleuchtung - Teil 2: Nutzenergiebedarf für Heizen und Kühlen von Gebäudezonen*.
20. T. Lichtenheld, A. Hollberg, and N. Klüber, "Echtzeitenergieanalyse für den parametrischen Gebäudeentwurf," in *Bauphysiktage Kaiserslautern*, 2015.
21. ISO 14040:2009 *Umweltmanagement – Ökobilanz – Grundsätze und Rahmenbedingungen*.
22. T. Kägi, F. Dinkel, R. Frischknecht, S. Humbert, J. Lindberg, S. De Mester, T. Ponsioen, and S. Sala, "Session 'Midpoint, endpoint or single score for decision-making?' — SETAC Europe 25th Annual Meeting," *Int. J. Life Cycle Assess.*, 2015.
23. Robert McNeel & Associates, "Rhino3D," 2015. <https://www.rhino3d.com/>. [Accessed: 08-Aug-2015].
24. BbgBO, *Brandenburgische Bauordnung*, no. 14. 2008, p. §40.

Geometry	Heating system	Building materials	U-value
<b>G1: Detached houses</b> 	<b>H1: Gas fuelled heat pump (air) + floor heating</b>	<b>M1: ETICS</b> Ext. walls: lime sand stone, EPS, plaster Roof: gravel, reinforced concrete, XPS Ceilings: floor tiles, reinforced concrete Int. walls: lime sand stone, plaster	<b>U1: EnEV 2002</b> Ext. walls: 0.45 W/(m <sup>2</sup> K) Roof: 0.30 W/(m <sup>2</sup> K) Slab: 0.50 W/(m <sup>2</sup> K) Win.: 1.30 W/(m <sup>2</sup> K)
<b>G2: Semi-detached houses</b> 	<b>H2: Electricity fuelled heat pump (earth) + floor heating</b>	<b>M2: Brick</b> Ext. walls: insulating brick, plaster Roof: gravel, reinforced concrete, XPS Ceilings: floor tiles, reinforced concrete Int. walls: brick, plaster	<b>U2: EnEV 2014</b> Ext. walls: 0.28 W/(m <sup>2</sup> K) Roof: 0.30 W/(m <sup>2</sup> K) Slab: 0.35 W/(m <sup>2</sup> K) Win.: 1.30 W/(m <sup>2</sup> K)
<b>G3: Row houses</b> 	<b>H3: Gas-condensing boiler + floor heating</b>	<b>M3: Concrete</b> Ext. walls: reinforced concrete, EPS Roof: gravel, reinforced concrete, XPS Ceilings: floor tiles, reinforced concrete Int. walls: reinforced concrete	<b>U3: Passivhaus</b> Ext. walls: 0.15 W/(m <sup>2</sup> K) Roof: 0.15 W/(m <sup>2</sup> K) Slab: 0.15 W/(m <sup>2</sup> K) Win.: 0.80 W/(m <sup>2</sup> K)
<b>G4: Apartment buildings</b> 	<b>H4: Gas-condensing boiler + radiators</b>	<b>M4: Wood</b> Ext. walls: wood cladding, timber frame, WFIB, OSB Roof: bitumen, timber beams, WFIB Ceilings: wood floor, timber beams Int. walls: wood cladding, timber frame	
<b>G5: Block</b> 	<b>H5: Woodchip boiler + floor heating</b>	<b>M5: Ventilated facade</b> Ext. walls: wood cladding, air layer, rockwool, lime sand stone, plaster Roof: gravel, reinforced concrete, XPS Ceilings: floor tiles, reinforced concrete Int. walls: lime sand stone, plaster	
<b>G6: Tower</b> 	<b>H6: District heating + floor heating</b>	<b>M6: Double shell masonry</b> Ext. walls: clinker brick, CIB, brick, plaster Roof: bitumen, timber beams, WFIB Ceilings: floor tiles, reinforced concrete Int. walls: wood cladding, timber frame	

Abbreviations:  
 EPS: Expanded polystyrene  
 XPS: Extruded polystyrene  
 PUR: Polyurethane  
 WFIB: Wood fibre insulation board  
 CIB: Cellulose insulation board

For all variants:  
 Slab: reinforced concrete, PUR;  
 Windows: PVC frame, double pane for EnEV 2002 and EnEV 2014, triple pane for Passivhaus  
 All components possess a fire resistance F60

Table 1: Overview of variants.



## Expanding Boundaries: Systems Thinking for the Built Environment

### ECONOMIC FACTORS FOR SUCCESSFUL NET ZERO ENERGY REFURBISHMENT OF DUTCH TERRACED HOUSES

A. Greco<sup>1\*</sup>, T. Jonathan<sup>1,2</sup>, B. Bogers<sup>1</sup>, A. van den Dobbelsteen<sup>1</sup>

<sup>1</sup>Delft University of Technology, Julianalaan 134, 2628 BL Delft, The Netherlands

<sup>2</sup>Reimarkt BV, Oosterhamrikkade 76, 9714 BG Groningen, The Netherlands

\*Corresponding author; e-mail: a.greco@student.tudelft.nl

#### Abstract

There are many smart technological solutions on the market for the zero energy refurbishment of the current building stock. The Delft University of Technology developed a zero energy renovation concept addressing 1.4 million post-war Dutch terraced houses: Prêt-à-Loger. By applying an integrated external renovation system (called the skin), the house becomes energy neutral while at the same time the living quality and the durability of the house are improved. This non-invasive renovation is designed to be applied to multiple houses. The project competed at the Solar Decathlon Europe 2014, winning five prizes, among which the first in sustainability. However, the team did not stop there; research continued in order to apply the concept in practice.

Despite the easy and fast applicability, the financial aspect still presents a barrier for large-scale implementation. This paper addresses the economic factors that can activate the investment on energy neutral house refurbishments. It summarizes the outcome of a one year interaction with public and local authorities, private companies, research institutes and end-users. The conditions created today by local subsidies and regulations for investments to take place are also addressed. Finally, the aspects that increase the value of the house, stimulating the investment are analysed.

#### Keywords:

Terraced house; refurbishment; economical value; net zero energy; renovation

### 1 INTRODUCTION

Across Europe only 1% of the building stock in any given year is newly built [1], about 70% of buildings are over 30 years old and about 35% are more than 50 years old [2]. Since the building sector is responsible for about 40% of the total Greenhouse gases (GHG) emission [3], massive refurbishment aiming at improving the performance of existing buildings seems to remain the most logical way forward towards a more sustainable and responsible usage of natural resources. Moreover, considering the new-construction rate, it is not difficult to imagine that most of the buildings present in 2050 have already been built at this moment [4]. These same buildings are in this sense responsible for achieving the required 80% reduced energy consumption compared to the 2008 levels [5]. Aiming at high standards of energy efficiency,

such as zero energy, for the existing environment is essential amongst others for residential buildings as they account for 70% of the building floor space [6]. Looking across the European building stock, both the quality and the scale of refurbishment need to improve [7]. This is why the Prêt-à-Loger team of the Delft University of Technology competed in the Solar Decathlon Europe 2014 (SDE2014) presenting a renovation concept rather than a new house, aiming at reaching energy neutrality. The Prêt-à-Loger concept addresses 1.4 million terraced houses in The Netherlands. This typology provides housing for 61.2% of the Dutch population and can furthermore be found abundantly in Northwestern European countries [8]. Approximately half of these row houses have been built as a response to the post-war shortage that required fast, inexpensive housing solutions for the middle

class in the period between 1946 and 1975 [9]. These houses are affected by a variety of issues such as high-energy expense, moisture problems and lack of liveable space. To address these problems and preserve this housing typology the renovation is designed as a noninvasive construction, an outer Skin, that allows the inhabitants to live in the house during the renovation (hence the name Prêt-à-Loger: *ready to live in*).

The skin integrates a number of measures to make the house energy neutral: roof-cavity, wall and crawlspace insulation, a mechanical ventilation system with heat recovery and Phase Changing Materials in combination with a greenhouse.

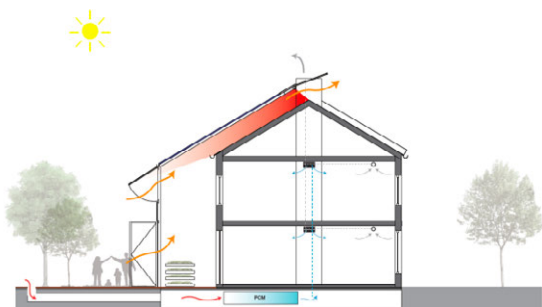

Fig. 1.1: Prêt-à-Loger climate design during summer.



Fig. 1.2: Prêt-à-Loger climate design during winter.

A smart domotics system controls all installations in the house and provides information about its performance to inhabitants. The skin can be seen as consisting of three parts: the North side's (post) insulation, including the North-side green roof, the internal installations and systems and the South-side greenhouse structure. The insulation, heat recovery and green roof are meant to reduce energy losses through the facades, while the greenhouse harvests the energy from the sun producing electricity, hot water and warm air. In spring and autumn, the greenhouse can be used as living space, during winter as a winter garden and in summer it becomes a covered terrace connecting the garden and the living room.

Prêt-à-Loger won a total of five prizes at the SDE2014, amongst which the first prize for sustainability and the third place overall. After the competition the house was rebuilt at the TU Delft campus for research and educational purposes. The success gained after the competition (with different awards, nominations and positive feedback from visitors) stimulated the team and the university to further investigate the economic feasibility of this energy neutral renovation concept.

This paper provides a thorough overview of the factors that affect the feasibility of the Net Zero Energy Refurbishment of Dutch terraced houses. The Prêt-à-Loger team of the Delft University of Technology investigated the applicability of the renovation concept together with potential investors, public and private authorities and research institutes.

## 2 ECONOMIC BARRIER

Over the past few years the government in the Netherlands has stimulated the development of so-called "Nul-op-de-meter" (zero-on-the-meter" i.e. net zero energy) renovation concepts for terraced housing ('rowhouses'). The overarching organisation coordinating this stimulation, the "Stroomversnelling", proposes a target price for these renovations of €45,000 for a complete net zero energy renovation concept for a rowhouse in the private sector [10]. Because of subsidies related to this fixed target-price, cost benefits on energy savings are often taken as a main criterion by builders to decide which renovation measures will be taken. Most concepts have similar approaches: almost all renovations consist of post-insulation measures, use of a heat pump, ventilation heat recovery systems, photovoltaic and sometimes minor additional measures to improve performance. However, based on current construction methods builders are incapable of creating a renovation achieving both the energy reduction as well as the target pricing. The Prêt-à-Loger team considers the focus on energy savings alone one of the main shortcomings of the approach taken. When analysing the value of a net zero energy refurbishment (or renovation) more aspects could be considered, creating a much more attractive package. In this paper these additional factors are explored, contributing to increasing the value of NZER in the challenging environment it faces. Awareness of these additional economic factors that can contribute to a renovations value, both in the decision-making and design phases, can help contractors in creating feasible renovations.



### 3 FINANCIAL FACTORS

The value of refurbishment is influenced by a number of financial factors introduced below.

#### 3.1 Energy Savings

The first and main factor addressed by the *Energiesprong*, is the cashflow that is freed up by the energy savings, caused by the renovation. This cashflow is relevant for both private homeowners as well as housing associations. Homeowners of Dutch 1946-1979 rowhouses have an average energy expense of €175,- per month, which if expressed in a mortgage as suggested by the *Stroomversnelling* adds up to €45,000 over a 30 years period. Under certain conditions housing associations are allowed to charge residents with a so-called *Energie Prestatie Vergoeding* [11]. This energy performance compensation should compensate for the expenses housing associations make in reducing the energy consumption of the house. Dutch legislation allows banks to provide an additional sum in the form of a mortgage at this moment potentially up to €27,000 [12].

#### 3.2 Property Value

Another relevant factor is the increase of property value. The appraised value depends on the type of renovation and the specific setting of the house and is normally estimated using previous valuations or by comparing the renovation to comparable interventions.

This increase of value is potentially driven by various aspects. Usually increased surface area and aesthetic aspects are main drivers. For net zero energy refurbishments the value increase will also originate in part from the energy savings and changed maintenance requirements. Particularly in respect to components needing maintenance to keep performance up to required level, such as for ventilation systems, the value increase will be more limited than of permanent components such as insulation.

The increase of property value forms a potential option of realising the renovation through refinancing the house, as long as the income of the homeowner is sufficient. To make this even more attractive, Dutch banks are allowed to provide a loan to value (LTV) of 106% for NZER opposed to a 100% LTV for normal mortgages as of 2018 [13].

#### 3.3 Maintenance

The change in maintenance costs before and after renovation is a relevant factor as well.

New installations like PV-panels, heat exchangers and heat pumps will introduce new maintenance costs. Over the course of a 30-year mortgage all these installations have to be replaced at least once. On the other hand, the renovation itself makes up for overdue maintenance and a smart design in combination

with the right choice of materials can reduce the cost of general maintenance even more.

#### 3.4 Vacancy rate

The vacancy rate could potentially decrease, positively impacting the value of renovated houses for housing associations and other landlords. Furthermore, when selling the house the time on the market is potentially decreased.

#### 3.5 Increase of rent

The increase of rent is the last financial factor influencing the value of NZER. If a house has a better energy label [14], or a larger surface area, housing associations or landlords can ask for a higher rent [15]. This can be expressed as an increase of rental income. It should be noted however that with regards to affordability of social housing a rental increase for housing associations might not always be desirable.

## 4 PRÊT-À-LOGER

*Prêt-à-Loger* is a NZER and an example of a refurbishment in which cost and energy reduction were not the only drivers. The main objective of the team was to find optimal technical solutions providing a usable and attractive sustainable renovation for the user, in order to win the *Solar Decathlon Europe 2014* competition.

While designing the team has researched what the problems with post-war terraced houses really are and has taken into account what the wishes and needs of the homeowner are. One of those wishes was additional space on the ground floor. An extension such as a 'serre' (conservatory), arguably very similar to the greenhouse in our design, offers such a space at a typical price around €25,000 [16]. By integrating this with a climate buffer offered by the greenhouse, several functions are captured in one solution. By looking at what a homeowner would be willing to invest in the first place and making that part of the design, the latter became more attractive resulting in an increased value of the house.

Enthusiasm seems to exist for different types of sustainable renovations such as those offered in the *Stroomversnelling* deal at €45,000, based on the reduction of €175 of energy expenses in a period of 30 years [17]. However, in practice such renovations cannot be realised yet at cost level, let alone at profit, implying contractors realise such renovation with the intention to learn and potentially open up a market in a later phase. When implemented across a street some contractors estimate their cost price to be around €90,000 for their own renovation, while the *Prêt-à-Loger* design is estimated to be around €100,000. After valuations were performed on several *stroomversnelling* NZERs, including our design, the results showed a clear distinction.



Fig. 4.1 : 1:1 Prototype of the Prêt-à-Loger house at the TU Delft Campus.

The Prêt-à-Loger house had an increased appraisal value of €37,000 compared to other renovations achieving around €5,000–€10,000 increase, mainly because of the additional space the renovation provides. Such an increase is of positive influence on the feasibility of the renovation particularly for homeowners, who can make use of additional mortgage. Banks consider characteristics such as an increase in appraisal value a key part in their risk assessments [18]. The valuation of our design shows a promising appraisal value, the costs however are still considerably higher than the increase in value, forming a clear barrier towards realisation.

Together with a main sponsor, a large contractor, several sessions were organised to attempt to decrease the price of the renovation to a more attractive level. Even with considerable up scaling of production it seems the results were still insufficient. Although the attractiveness of our proposition was recognised, NZER propositions were considered to be infeasible in general for mass application on Dutch terraced housing.

Although the design up to this point has not led to a feasible renovation seeing implementation in practice, there are other values that have come forward in our design. The more extensive exploration of adding value has not only showed in enthusiasm by visitors, but in a considerable increase in value through the renovation as well. Such value is a step towards financial feasibility, potentially forming a key part in creating a more sustainable housing stock.

Residents are mostly interested in the benefits and additional qualities they will get from sustainable renovation [19]. Extending the proposed value beyond efficiency and reducing costs into other qualities such as additional space or improved quality of living appears a sensible direction in this respect. Such additional qualities increase the willingness to pay of residents.

## 5 CONCLUSIONS

The Dutch Stroomversnelling project produced several prototypes for zero energy renovations, combining measures of post-insulation, new building services and efficient ventilation strategies. Compared to these the Prêt-à-Loger house of the TU Delft team, designed for the Solar Decathlon Europe 2014, added an important element that creates added value to just a lower energy bill and better indoor comfort: a glasshouse that entails extra living space, possibilities for food production and of course a heat buffer for the house's energy system.

The economic case of Prêt-à-Loger demonstrates that the financial feasibility of zero-energy refurbishment is difficult but not impossible. The large-scale renovation of millions of dwellings, which now perform poorly in energy terms, will be possible if the following conditions are met.

Firstly, current standards in financial boundary conditions need to be changed in order to facilitate energy renovations, creating investment money from the energy saved after renovation. This is a new paradigm in the financial world of mortgages and rent versus energy bills. Governments can enforce this with banks, insurance companies and other possible funding corporations.

Secondly, smart and bioclimatic design principles, using local circumstances optimally in the redesign of the house, can be applied to refurbish existing houses in an efficient and feasible manner.

Thirdly, and in conjunction with the previous, architects, technical designers and engineers should take economic factors into account when approaching existing houses. So far this has mainly been a task of the builder and developer, but with a layman commissioner as a common

people living in these houses, some more responsibility will come to lie with the (re) designing party, for whom working in a multidisciplinary team, in a co-creation process, therefore is recommendable.

Fourthly, creating added value to the house when renovating it will be more expensive but decisive for the economic value of the object and, not least, the living quality of the home-owner or – user.

Additional research is needed as to get better grip on the actual performance of houses before and after the interventions, and the financial consequences. Honesty with these figures is recommended, as history has shown that negative results withheld from the public ricocheted in the end. The challenge the world faces in terms of climate change and energy poverty requires an open attitude, boldness to try new concepts and willingness to learn from mistakes. With that in mind, the Prêt-à-Loger project has been very valuable to the public, university and students who now go onto the market to work on a sustainable built environment.

## 6 REFERENCES

1. Frits Meijer, Laure Itard, Minna Sunikka-Blank, Comparing European residential building stocks: performance, renovation and policy opportunities, *BUILDING RESEARCH & INFORMATION*, 2009, vol. 37(5-6), p. 533–551.
2. B. Poel, G. Van Cruchten, C.A. Balaras, Energy Performance Assessment of Existing Dwellings & Non Residential Buildings, *Energy and Buildings* 39, 2007, p. 393–403.
3. L. Pérez-Lombard, J. Ortiz, C. Pout, A review on buildings energy consumption information *Energy Build*, 40 (3) (2008), p. 394–398
4. Fernando Pacheco Torgal, Marina Mistretta Artkras Kaklauskas, Claes G. Granqvist, Luisa F. Cabeza, Nearly Zero Energy Building Refurbishment, A Multidisciplinary Approach. 2013 Springer London.
5. European Commission, Energy 2020: A strategy for competitive, sustainable and secure energy. 2010, Communication From The Commission To The European Parliament, The Council, The European Economic And Social Committee and the Committee of The Regions.
6. L. Itard, F. Meijer (2008), Towards a sustainable Northern European housing stock, IOS, Amsterdam.
7. A. Greco, T. Konstantinou , H.R. Schipper , R. Binnekamp , E. Gerritsen , R. de Graaf , A. van den Dobbelsteen (Submitted), Business Case Study for the Zero Energy Refurbishment of Commercial Buildings, Sustainable Built Environment (SBE) regional conference.
8. Eurostat (2012). Distribution of population by dwelling type, 2012 (% of population). from [http://ec.europa.eu/eurostat/statisticsexplained/index.php/File:Distribution\\_of\\_population\\_by\\_dwelling\\_type,\\_2012\\_\(1\)\\_\(%25\\_of\\_population\)\\_YB14\\_II.png](http://ec.europa.eu/eurostat/statisticsexplained/index.php/File:Distribution_of_population_by_dwelling_type,_2012_(1)_(%25_of_population)_YB14_II.png)
9. B. Bogers, D. van den Berg, Sake Zijlstra, Peter de Jong (2014); The influence of end user perception on the economic feasibility of sustainable building skin renovations.
10. Housing Europe (2015). Transition zero. Available at: <http://www.housingeurope.eu/section-100/transition-zero>
11. EnergylinQ (2015). Wetgeving Energieprestatievergoeding. Available at: <http://energielinq.nl/resources/epv>
12. Rijksoverheid (2015), Tijdelijke Ministeriële Regeling Hypothecair Krediet. Available at: <https://www.rijksoverheid.nl/documenten/regelingen/2015/10/19/tijdelijke-ministeriele-regeling-hypothecair-krediet>
13. Rijksoverheid (2015). Kamerbrief inzake maatwerk bij hypotheekverstrekking, available at: <https://www.rijksoverheid.nl/documenten/kamerstukken/2014/07/03/kamerbrief-inzake-maatwerk-bij-hypotheekverstrekking>
14. TU Delft (2016). Energy label. Available at: <http://www.tudelft.nl/en/current/dossiers/archive/energy-label/>
15. Rijksoverheid (2015). Puntensysteem zelfstandige woning. Available at: <https://www.rijksoverheid.nl/onderwerpen/huurwoning/inhoud/puntensysteem-huurwoning/puntensysteem-zelfstandige-woning>
16. Uitbouwkosten (2016). Wat kost een aanbouw van 3 meter?. Available at: <http://www.uitbouwkosten.nl/wat-kost-eeen-aanbouw-van/3-meter/>
17. Energiesprong (2014) Stroomversnelling Koop – 24 – uurs startbijeenkomst Innovatiecoaches. Available at: <http://www.energiesprong.nl>
18. D. van den Berg, (2015). A different approach to the improvement of the fundability of sustainable renovations for private homeowners. Real Estate & Housing. TU Delft.
19. A. van Eck, (2008). De 'Willingness to pay' voor een energiezuinige nieuwbouwwoning. Real Estate & Housing. TU Delft.





## Expanding Boundaries: Systems Thinking for the Built Environment

### SUSTAINABILITY INDICATORS FOR BUILDINGS: NETWORK ANALYSIS AND VISUALIZATION

L.C. Tagliabue<sup>1\*</sup>, M. Manfren<sup>2</sup>

<sup>1</sup> University of Brescia, Department DICATAM, Via Branze 43, 25123 Brescia, Italy

<sup>2</sup> University of Bologna, Department of Industrial Engineering (DIN), Viale del Risorgimento 2, 40136, Bologna, Italy

\*Lavinia Chiara Tagliabue; e-mail: chiara.tagliabue@polimi.it

#### Abstract

Nowadays rating systems to assess the sustainability of the built environment are available worldwide. The idea that a rating system based on indicators and a sustainability score can guarantee architectural quality, reliability, energy efficiency, economic convenience and finally a sustainability label, produces an increased value of the building on the real estate market giving an "aura" of advanced product to the building itself. It is well known that different rating systems can give a different sustainability score because similar areas of evaluation in different rating systems are not equal in term of indicators' weight. Moreover, the continuous updating of the rating systems tries to include in the assessment procedures a tailored vision coming from field experience. The building rating systems were born in the last 15 years (i.e. 1998-2004), while rating systems for urban districts are more recent (2009-2012). The paper provides a survey on the more influential and worldwide diffused rating systems, highlighting the differences in terms of organization and relationship between evaluation areas and comparing existing rating schemes with recent EU research projects and initiatives such as the "Common European framework for Sustainable Building Assessment" (CESBA) framework. The paper aims to report the preliminary analysis on the similarities and differences among rating systems, towards a harmonization of sustainability practices to be applied to new and existing buildings. A network analysis and visualization tool has been applied to show the structural analogies among rating systems through an innovative methodological approach which aims to enable a further development in this field by linking more directly these tools with computational tools used in the building lifecycle.

#### Keywords:

Sustainable buildings; sustainability rating systems; network analysis; visualization techniques

### 1 INTRODUCTION

Rating systems have been being used in the world since approximately 15 years as tools to enable a holistic view of sustainability in building and, more recently, district design practices. The Report of the World Commission on Environment and Development "Our Common Future", known worldwide as Brundtland report [1] dated 1987 promoted the starting point to develop, in roughly 10 years a systemic vision of sustainability in buildings based on the three pillars of environment, economic and society. Sustainability

rating systems started mainly as environmental assessment tools, but evolved into more general tools (including environmental, economic and societal dimensions), used today in different countries [2,3], in some cases customized for specific national characteristics.

Translating a rating system into regional or local realities is not an easy task, because of a different cultural, economic and environmental (i.e. geography, climate) background [4,5]. Even though there is not always strong evidence of the whole improvement of the certified buildings in

comparison with not certified buildings [6] and a relevant variability can be encountered with respect to specific indicators and evaluation areas [7,8] in the wide panorama of rating tools. Despite the growing number of design and assessment tools, a particular set of tools appears to dominate the real estate market. The building environmental assessment tools, such as LEED (the oldest), BREEAM and SBC have significantly affected both the public and the market awareness and the perception of what a sustainable building is. Some topics, included in the rating systems, such as energy performance, has, in most countries, a required level based on the national baseline requirements. In some countries where limited attention is devoted to energy problems, these tools are used as design guidelines, instead of their original objective as assessment tools [9]. A side effect of this mindset is that rating systems, which are mainly structured as check lists, are used simply to reach a useful quality threshold for market placement of the real estate properties, rather than concentrating on a real project optimization. For example, while in general we can aim at achieving a high score, in some cases local, economic, structural or technological constraints could be optimally satisfied even with a lower score and in a more rational way, responsive to the original building purpose [10]. Intrinsically, the value of the rating systems is in the holistic view including specific topics strongly correlated between them that are not so evident in the check list structure [11,12].

## 2 VISION AND VISUALIZATION

Because of the multiplicity of rating systems, we are currently in a situation where everybody is making "truth claims" [13] on ways to develop sustainable designs based on diverse epistemic criteria and worldviews. In fact, it does not seem possible to keep up with the major problem that has brought forth this concept into scene such as the crisis of perception triggered by an out-dated mechanistic/modernist worldview, which is related with "anthropocentric" worldview.

Conceptualizations about the world are strongly tied to the dominant worldviews. Our worldview shapes our values, theories and preconceptions and these, in turn, determine the problems we perceive, the knowledge we seek and the actions we take [14]. Developments especially in the field of physics and biology, and then in systemic revealed that the mechanistic worldview gave a misrepresentation of the world. Through an anthropocentric approach to nature, this worldview deciphered world phenomena as a deterministic clockwork based on a Cartesian approach that can be analysed and understood by the division of the whole into its parts. This difference in perception has actually prepared the ground for the loss of synch between human's

time and nature's time, and by consequence has induced sustainability problems. Furthermore, it has rendered human minds unable to comprehend the challenge of sustainability. While favouring notions such as simplicity, certainty and immediacy, it has served to impede adaptive learning deemed essential for sustainability [15]. Researchers revealed that the world is not built upon such deterministic relationships that can be analysed through the so-called part and whole division suggested by analytical thinking. The major problems of our times cannot be understood in isolation. They are systemic problems, which means that they are interconnected and interdependent [16]. Current literature underscores the fact that world phenomena are formed of networked elements, which have complex and nonlinear characteristics. Therefore, sustainability can only be addressed through a holistic thinking that enables humans to conceive the world out of networked elements, as outlined in Fig.1 [17].

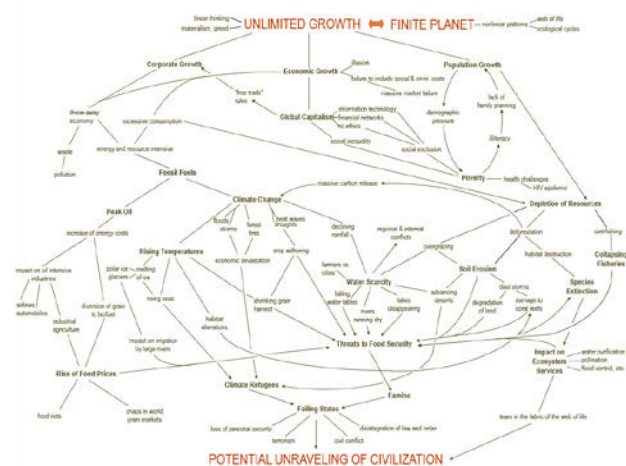

Fig. 1: Conceptual Map (source F. Capra, 1995).

The conceptual map in Fig. 1 dates back to 1995, nowadays new visualization tools are available to show connections and to reveal the overall structure of the organization of information.

The research starts with the analysis of the areas on which the sustainability criteria are structured in the selected rating systems. By applying advanced analysis and visualization techniques relationships and overlapping are revealed together with the lack of parameters or connections among some significant factors affecting building sustainability.

## 3 DATA COLLECTION, ANALYSIS AND VISUALIZATION

### 3.1 Rating systems or protocols

The essential data used in the present study is derived from a more extensive research on rating systems for building and district scale and it is focused on the building level. The selected protocols are the following ones:

- LEED: Leadership in Energy and Environmental Design;
- BREEAM: Building Research Establishment Environmental Assessment Methodology;
- SBC: Sustainable Building Council;
- DGNB: Deutsche Gesellschaft für Nachhaltiges Bauen;
- ITACA: Istituto per l'innovazione e la Trasparenza degli appalti e la Compatibilità Ambientale.

The protocols have been selected considering age, updating, diffusion, flexibility and applicability. Table 1 resumes the chronological data and the country of origin of each protocol.

Name	Year	Update	Country
LEED	1998	2014	USA
BREEAM	1993	2013	UK
SBC	1996	2012	Canada
DGNB	2004	2012	Germany
ITACA	2004	2012	Italy

Table 1: Selected rating systems.

LEED and BREEAM and SBC are international tools of the first generation (started 10-15 years ago) while DGNB is a second generation tool and ITACA is a national rating system coming from SBC (see Table 2). In Table 2 the institute and diffusion of the tools are specified while in Table 3 the areas of rating system, the number of typologies of building end-uses considered and the number of quality level or score are resumed.

Name	Institute	Diffusion
LEED	USGBC, GBC Italia	International
BREEAM	BRE Global (SBA)	International
SBC	SBC*	International
DGNB	SBC*, SBA**	International
ITACA	Itaca, iiSBE, SBA*	National

\*Sustainable building Council  
\*\*Sustainable Building Alliance

Table 2: Institute and diffusion of rating systems.

Name	Areas	Typology	Levels
LEED	7	8	4
BREEAM	10	10	5
SBC	6	9	score
DGNB	6	10	3
ITACA	5	5	score

Table 3: Areas, typologies and levels.

### 3.2 Analysis and visualization tool

The analysis and visualization tool adopted in this research is Gephi. Gephi is an open-source network analysis and visualization software package written in Java on the NetBeans platform [18] initially developed by students of the University of Technology of Compiègne (UTC) [19] in France. Gephi has been used in a several projects in academia, for large-scale network analysis problems (e.g. social networks, technological networks, etc.).

## 4 RESULTS

### 4.1 Visualization of connected criteria

Each rating system has different evaluation areas used to gain points to achieve a sustainability level. These areas have different names and mixed contents but they present many similarities that can be detected by means of network analysis. For this reason, we started to analyse every single protocol as a network and we found in LEED very interesting characteristics. Each rating system can be represented by a tree of areas and sub indicators (Fig. 2-5) but only LEED (in its user manual) includes for each indicator the connection with other indicators providing a more interesting map of correlation among credits and design choices in different areas (Fig. 6). The visualization tool allows to analyse statistically the relevant network metrics of nodes and edges, providing also a range of algorithms to distribute the conceptual map configuration and to set visualization options in order to put in evidence different relations (Fig. 7).



Fig. 2: Network visualisation of BREEAM areas and indicators.

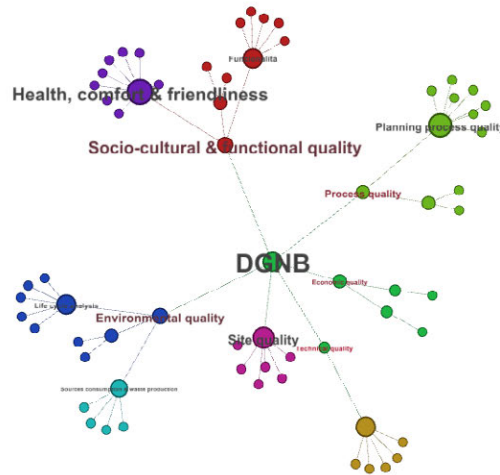

Fig. 3: Network visualisation of DGNB areas and indicators with partition defined by modularity class.

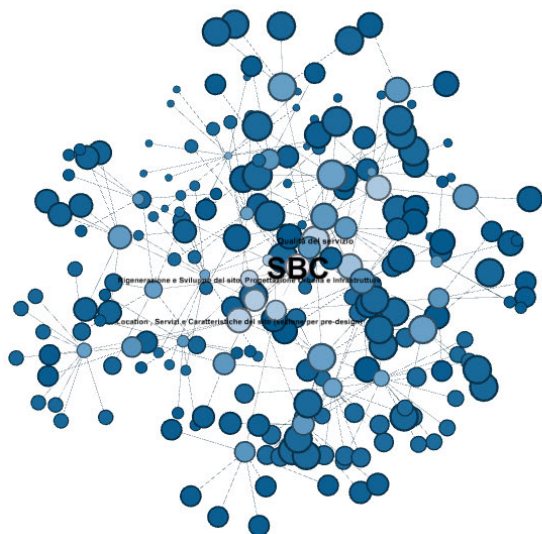

Fig. 4: Network visualization of SBC areas and indicators with colours defined by closeness/centrality.

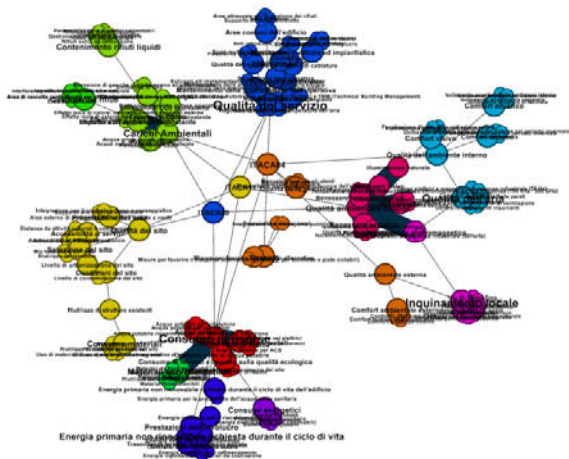

Fig. 5: Network visualisation of ITACA areas and indicators with partition defined by modularity class.

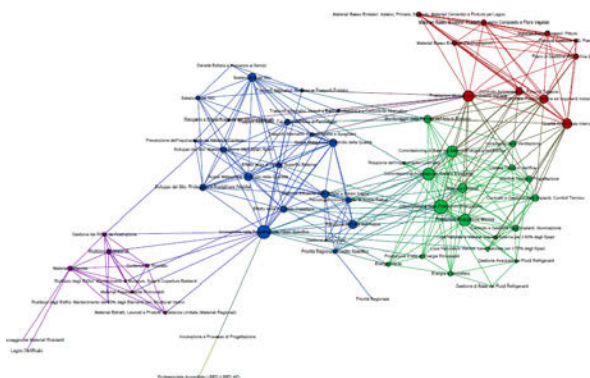

Fig. 6: Network visualization of LEED areas and indicators and connections between them with colours defined by clustering.

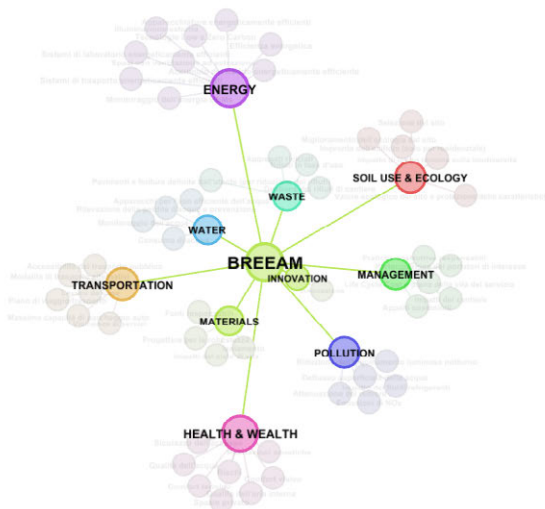

Fig. 7: Network visualization of BREEAM areas.

#### 4.2 Statistical analyses on the network

The statistical analyses that can be performed to examine networks with respect to their metrics are reported in Table 4. The network visualization can be enriched with more information such as weights/credits in multi-criteria analysis and scoring; these elements are not considered at this stage of the development of the research and will be investigated more in depth in further developments. In the LEED map where the criteria connections are provided by the user manual and these data have been added in the map, it's possible to verify a much higher clustering coefficient of the network (zero for other protocols where the indicators connections have not yet been introduced). A value greater than zero could also be found for ITACA map where an analysis on evolution of the criteria in the tool from the first version (2004), to the intermediate version (2009) and finally to the current version (2011) has been performed.



	LEED	BREEAM	SBTool	DGNB	ITACA
<b>Network overview</b>					
Average degree	9.39	1.97	1.99	1.97	2.23
Avg. Weighted degree	9.39	1.97	1.99	1.97	2.49
Network diameter	6	4	6	6	8
Graph density	0.15	0.03	0.01	0.03	0.01
Modularity	0.46	0.75	0.86	0.76	0.79
Connected components	1	1	1	1	2
<b>Node overview</b>					
Avg. Clustering coefficient	0.59	0	0	0	0.02
<b>Edge Overview</b>					
Avg. path length	2.52	3.42	5.25	4.54	4.91

Table 4: Preliminary analysis on the sustainability rating system networks for the main tools.

### 4.3 Shared areas of evaluation

The analysis can be developed to define relation and overlapping (or knowledge “holes” to focus on) checking the shared areas of evaluation of the different rating systems (Fig. 8). In the network the areas shared by two tools are red while the green ones are shared by three tools and the yellow one is shared by the whole rating systems. The areas related to economics and socio-cultural issues are taken into account only in DGNB and SBC; LEED and BREEAM are more connected in comparison with the other tools nevertheless the weight that any tool gives to the areas is different and this is a further element of research, as expressed before.

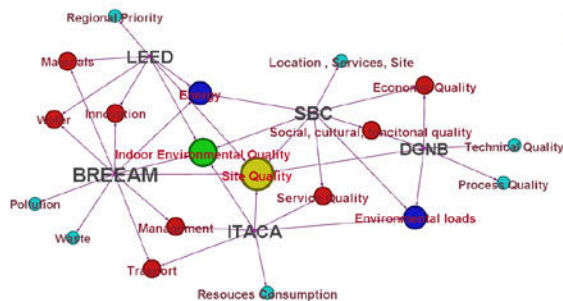

Fig. 8: Shared areas by different protocols.

## 5 DISCUSSION

The development of effective building energy and environmental assessment tools and practices is necessary to ensure efficient design and operation [20]. Efforts to connect in a whole systemic vision the different tools gave origin to relevant European research projects [21]. In the EU Superbuilding

Project [22] a synoptic definition of the imperative areas of evaluation is provided and extensively described for the different phases of the sustainability evaluation (design phase, construction phase, operation phase). Further, CESBA (*Common European Sustainable Building Assessment*) is a recent initiative aimed at harmonizing the evaluation areas and tools for assessment. A visualization of the shared areas between CESBA and the synthesis of the EU Superbuilding Project is presented in Fig. 9, showing the main differences.

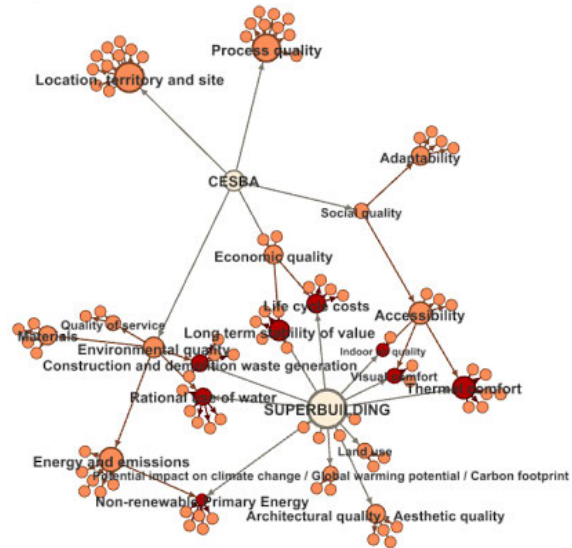

Fig. 9: Areas shared by harmonization frameworks CESBA and EU Superbuilding Project.

## 6 CONCLUSIONS

The use of network analysis and visualization techniques to compare sustainability assessment tools is aimed at improving the applicability of these tools for design and operation purposes. In the microscale visualization, it can be used to underline the effects of technological solutions on different aspects in interconnected areas; in the macroscale, a holistic view of the building should promote an innovative design and problem solving approach through system thinking. Finally, the structural analogies among different rating systems can be explored for a further development in the field, obtainable by linking more directly the relevant information contained in the rating systems with the computational tools used in the building lifecycle, for effective decision-making, and, in a future perspective, directly with data acquired by means of multiple devices, within the “Internet of Things” paradigm.

## 7 REFERENCES

1. Brundtland G.H., Report of the World Commission on Environment and Development Our Common Future, WCED 1987.
2. Reed R., Wilkinson S., Bilos A., Schulte K., A comparison of International Sustainable Building Tools – An Update, The 17<sup>th</sup> Annual Pacific Rim Real Estate Society Conference, Gold Coast, (2011) 16-19 January.
3. Liu G., Nolte I., Potapova A., Michel S., Ruckert K., Comparison of worldwide certification systems for sustainable buildings, SET2010 – 9<sup>th</sup> International Conference on Sustainable Energy Technologies (2010) Shanghai, China, 24-27 August.
4. Alyami S.H., Rezgui Y., Sustainable building assessment tool development approach, *Sustainable Cities and Society* 5 (2012) 52–62.
5. Motzl H., Fellner M., Environmental and health related criteria for buildings, IBO Österreichisches Institut für Baubiologie und – ökologie GmbH Austrian Institute for Healthy and Ecological Building, Final Report, (2011) Vienna 31/03.
6. Newsham G.R., Mancini S., Birt B.J., Do LEED-certified buildings save energy? Yes, but..., *Energy and Buildings* (2009) 41, Issue 8 Pages 897–905.
7. Ng S. T., Chen Y., Wong J.M.W., Variability of building environmental assessment tools on evaluating carbon emissions, *Environmental Impact Assessment Review* 38 (2013) 131–141.
8. Fowler K.M., Rauch E.M., Sustainable Building Rating Systems Summary, Pacific Northwest National Laboratory operated by Battelle for the United States Department Of Energy, July 2006.
9. Ruhi I., The Implications of the use of Building Environmental Assessment Tools within the Building Practice in Turkey, Doctoral Thesis, Politecnico di Milano, Building & Environment Science & Technology Department (2012).
10. Reed R., Wilkinson S., Bilos A., Schulte K., A comparison of International Sustainable Building Tools – An Update, The 17<sup>th</sup> Annual Pacific Rim Real Estate Society Conference, Gold Coast, (2011) 16-19 January.
11. Lupisek A., Multicriteria assessment of building in context of sustainable building, Doctoral Thesis, Czech Technical University in Prague, Faculty of Civil Engineering, Department of Building Structures (2013).
12. Berardi U., Sustainability Assessment in the Construction Sector: Rating Systems and Rated Buildings, *Sustainable Development* (2011).
13. Guy S., Moore S., Sustainable Architecture and the Pluralist Imagination, *Journal of Architectural Education* 60, no. 4 (2007), 16.
14. Cole R.J., Environmental Issues Past, Present and Future: Changing Priorities and Responsibilities for Building Design, Helsinki, World Sustainable Building Conference, October, 18-21, 2011.
15. Gladwin T.N., E.W. Newburry, Reiskin E.D., Why is the Northern Elite Mind Biased Against Community, the Environment, and a Sustainable Future? in *Environment, Ethics, and Behavior: The Psychology of Environmental Valuation and Degradation*, eds. Max H. Bazerman and others (San Francisco, California: The New Lexington Press, 1998), 243.
16. Capra F., Deep Ecology: A New Paradigm, in *Deep Ecology for the Twenty-First Century*, ed. George Sessions (Boston, MA: Shambhala, 1995), 19-25.
17. Capra F., Interconnectedness of World Problems: A Conceptual Map, [www.earth-policy.org/images/uploads/capra\\_pb3.ppt](http://www.earth-policy.org/images/uploads/capra_pb3.ppt)
18. Bastian M., Heymann, S., Jacomy, M., Gephi: An Open Source Software for Exploring and Manipulating Networks, AAAI Publications, Third International AAAI Conference on Weblogs and Social Media, (2009) retrieved 2011-11-22.
19. Desmedt P., Sébastien Heymann - Le cartographe des données, *L'Usine Nouvelle*, (2011) retrieved 2011-12-14.
20. Osaji, E.E., Suresh, S. and Chinyio, E. The Role of Building Energy and Environmental Assessment in Facilitating Office Building Energy-Efficiency. In: *Sustainability in Energy and Buildings*. Chapter 63, Vol. 22, pp.679-704. (2013) Springer Berlin Heidelberg.
21. Van Dessel J., LEnSE Methodology Development towards a Label for Environmental, Social and Economic Buildings, Final Report - 27 months PART 5: Publishable Final Activity Report (2008) Version 15/05/2008
22. VTT Technical Research Centre of Finland, Sustainability and performance assessment and benchmarking of buildings – Final Report, (2012) ISBN 978-951-38-7908-2 (URL: <http://www.vtt.fi/publications/index.jsp>), Technical editing Christina Vähävaara.



## Expanding Boundaries: Systems Thinking for the Built Environment

### INTEGRATING AN ENVIRONMENTAL AND SOCIO-ECONOMIC ASSESSMENT TOOL FOR THE DEVELOPMENT OF BROWNFIELD DEVELOPMENT PROJECTS

F. Cappai<sup>1\*</sup>, D. Forgues<sup>1</sup>, M. Glaus<sup>2</sup>

<sup>1\*</sup> GRIDD-ÉTS École de technologie supérieure, 1100 Notre Dame W , Montreal (Qc),  
Canada H3C 1K3

<sup>2</sup> STEPPE-ÉTS École de technologie supérieure, 1100 Notre Dame W , Montreal (Qc),  
Canada H3C 1K3

<sup>1\*</sup>Corresponding author; e-mail: francesco.cappai.1@ens.etsmtl.ca

#### Abstract

In the urban development process, stakeholders (local politicians, businessmen, academics, neighbourhood groups, etc.) involved in urban policies are required to make strategic decisions for their territory in a strategic manner. The available tools are poorly adapted for this process. The evaluation tools most commonly used (LEED, CASBEE, BREEAM and SBTool, etc.) have a complex structure and do not provide the results required in the case of brownfield projects. They do not include the involvement of all stakeholders in the early phases of the project. Moreover, their indicators are not equally distributed among the three dimensions of sustainable development (environmental, social and economic) to reflect the context and local expectations.

This paper presents a transversal and interdisciplinary study on sustainability that examines local indicators that can be used in brownfield projects. The study proposes the construction of an assessment tool derived from an analysis of the methods used in urban development projects.

The study considers a selection of 20 items related to restructuring case studies of North American and European brownfields. A multidisciplinary approach is used to consider the players involved in all phases of the project. The goal is to identify and classify the elements that are needed for decision making, including the indicators related to environmental and socio-economic components, in order to develop an effective evaluation tool.

#### Keywords:

Sustainable building; brownfield; sustainability assessment; sustainability coverage; subjectivity; adaptability; applicability

## 1 INTRODUCTION

Urban population has grown rapidly over the last century (US Census Bureau, (World population) 2015 [1]). Also, the demand for land has increased rapidly and the total value of land and real estate has increased steadily over the last 40 years [Isaac, 2002 cited by 2]. Climate change, loss of biodiversity and environmental pollution make it imperative to intervene in the planning of cities and their components (UNEP, 2014 [3]). In the development process of cities, stakeholders involved in urban policies have been called upon to make strategic decisions for their territory [4]. The redevelopment of brownfield sites is now

considered a sustainable land use strategy [5]. Until recently, these sites had been neglected by developers in favour of "greenfields" because of the high costs of soil remediation and the upgrading of existing infrastructure [6]. Our research aims to develop an intervention framework for analysis and decision making.

This paper presents the first part of research that aims to identify the literature for the framework of intervention. Here are the three stages:

(i) Identification of the stakeholders involved in a brownfield redevelopment process and their involvement in the project's phases; (ii) identification of the dimensions covered in each

study and the association of thematic fields; and (iii) identification and classification of indicators for each dimension. This classification is the basis for developing an effective evaluation tool for the redevelopment of brownfield sites.

## 2 THE CHALLENGES OF UPGRADING BROWNFIELDS

The restoration and redevelopment of brownfield sites can provide economic, social and environmental benefits, including environmental quality restoration, improvement of the quality of life for citizens, improving health, providing land for commercial housing and the creation of employment within the urban environment [7-9]. The link between scientific and local knowledge can contribute to a better understanding of the implications of sustainable development [9, 10]. The assessment tools have become sectoral approaches that consider one dimension over another. The best-known assessment tools, LEED-ND® (North America), BREEAM Communities (UK), SBTool, GreenStar (Australia), and CASBEE-UD (Japan) [11], are voluntary approaches to assess projects according to the project's scale, using their own indicators to achieve certification. Despite their lack of consideration of social and economic aspects [11], these sets of standards contribute to a sound knowledge base but only yield partial results. A true evaluation tool must incorporate all of the sustainable development issues. It must be able to clearly identify the project objectives and classify and prioritize them based on local interests. A new methodological framework (a summary presentation in the form of a table and the list of a project's development criteria) must be built. This methodological framework should be characterized by a multi-criteria, transversal and comprehensive approach to move towards sustainable development. The assessment tools would need to be guided by the normative vision of sustainability, and at the same time be directed towards a framework for the implementation of the users' various requirements [8]. A key factor for success at a local level is the ability to contextualize a project for its city. This contextualization can be achieved through the participation of local stakeholders who can help in the design of policies, plans or projects that best meet the needs of local communities [11]. Experience with participation in strategic planning design and specific local governance by process could reduce the uncertainty associated with future redevelopment and investment promotion [McCarthy, 2002, Nijkamp et al., 2002 cited by 9]. Sustainable development, design issues and project development must be interlinked to create a real process [4].

## 3 RESEARCH METHODOLOGY

The first part of the research consists of a report on methodological approaches and frameworks; international tools that are completed or under development. The identification of these fundamental elements will identify their roles and their organization in the redevelopment project structure. Our analysis is based on the identification of criteria, targets and indicators. The objectives are to propose a set of criteria that characterize urban redevelopment projects and to carry out the identification of dimensions and stakeholders in order to best select and classify the indicators associated with each dimension.

### 3.1 The dimensions of identification

Of the 20 selected articles, 13 are based on the three classical dimensions of sustainable development, environmental, social and economic. Only 7 articles stress the importance of adding and evaluating appropriate indicators of socio-cultural dimensions. Addressing only one or two themes is not enough to implement a process for achieving sustainable urban development. As several authors have indicated [8, 9, 12] the objectives of sustainability must be addressed in order to achieve an approach that deals with registering a redevelopment project in the urban fabric in a sustainable way. We chose a combination of thematic and aggregation through an analysis of case studies. This study consists of three phases: 1) A comprehensive inventory of the thematic areas covered in the literature. in order to select the subject areas that encompass all the dimensions of sustainability to be integrated into a neighbourhood project. This inventory of thematic areas consists mainly of existing tools, research, and field work: LEED-ND 2009, BREEAM Communities, CASBEE-UD, SBTool, and Green Star [11]; 2) A selection and aggregation of the thematic areas that are most often discussed in these studies; and 3) A selection of criteria which include sustainability aspects. The choice guided by these criteria can thus classify the thematic fields into three dimensions: environmental, socio-cultural, and economic. These three dimensions are then translated into eight thematic fields, summarized in Table 1.

Dimension	Thematic field
Environmental valuation	Natural Resource Management (Stormwater, sewage, alternative energy, etc.), biodiversity, quality of natural areas
	Environmental protection (floodplains, rivers, lakes, parks, wetlands, animals, etc.)
	Improved comfort and health (site pollution )
Equitable social value and social responsibility	Strengthening cohesion and social equity
	Enhancement of the architectural (buildings and materials) and historical heritage (preservation of historical memory)
Economic strategy	Cost reduction
	Increase of cohesion (accessibility and transportation) and economic dynamics (employment and business)
	Multi-functionality of the territory, territorial competitiveness

Table 1: Dimensions and individual thematic fields in articles.

### 3.2 Identification of stakeholders

Following the literature review (20 relevant articles on brownfield redevelopment) seven stakeholder groups have been identified. The analysis in the articles led us to reflect on the need for a renewal of the identification of the stakeholders involved in a brownfield redevelopment project. Their involvement was classified based on the respective project phases (Table 2). The goal was to identify the level at which each group of stakeholders is involved in decision making. It is in this context that the roles of these stakeholders become more complex and varied. Without going exhaustively into the modality of participation, we can distinguish groups of key stakeholders in a sustainable project process. As shown in Table 2, these actors have been classified into seven groups according to their level of intervention and also in terms of their participation in the project hierarchy according to their discipline. The participation of stakeholder groups in the project phases is essential, but each stakeholder group must contribute specifically at certain phases of a project to achieve a successful sustainable urban redevelopment. We identified two levels of participation: essential and conditional. The first

five stakeholder groups are classified as essential, while the last two groups are considered to have conditional participation in the design phase and project assessment. This latter classification is given to citizens who had not yet been included in the project phases. [7, 10, 11, 12]. This approach puts people at the centre of decision making and permits them to play a decisive role in the evolution of new solutions and to promote sustainability [10, 11].

Group of actors	Public or Private	programming	design	implementing	use
National policy makers	National Policy, Ministerial, administration	x			
Local policy makers	City and community	x	x		x
Institutions and associations	Urban services, service companies, associations, local housing authority, non-governmental partner, academics, building managers	x	x	x	x
Master of private work	Investors, developers, private landlords	x	x		
Master of implementable and experts	Consultants designers, urban planners, sociologists engineers, consultants,experts,renovation agencies	x	x		
Operational actors	Companies, private contractors, technicians, craftsmen		x	x	
Users	Citizens (owner, tenant),neighbors, employees		x	x	x

Table 2: Involvement of stakeholder groups in a project's phases.

This group of players can be a driving force that not only motivates new policy decisions and the actions of professionals, but who also intervene directly in a project [10, 14-19].

## 4 TOWARD A NEW METHODOLOGICAL APPROACH TO PROJECT EVALUATION

### 4.1 Selection and classification of indicators associated with their dimensions

Table 3 provides a detailed description of the indicators used in each case study and the objectives identified for each project. By analysing Table 3, it can be observed that the number of indicators considered is different for each author.

Authors	Number indicators		
	Env.	Soc.	Eco.
[20]	1	8	5
[5]	13	8	9
[21]	17	21	13
[22]	10	20	10
[2]	1	1	9
[14]	9	16	8
[23]	2	6	3
[8]	5	5	5
[12]	14	18	8
[24]	4	4	2
[25]	0	0	2
[17]	9	5	8
[18]	7	6	1
[9]	5	4	3
[4]	8	11	7
[26]	4	4	9

Table 3: Indicators and targets used in the literature.

All the models concur that all three dimensions should be covered and that the social and environmental aspects should have a greater amplitude, especially when planning developments affecting brownfield problems. The tools assessed here are not able to adequately assess all three dimensions. Some indicators are related to urban forms yet are not treated with the appropriate tools. Another observation is that the number of indicators becomes less representative in some studies and that project objectives sometimes take the place of indicators. This project evaluation allows us to see the shortcomings of the tools used by

professionals and municipalities, deduced from the intersection of the themes and indicators of the tools used in the case studies.

### 4.2 Proposed methodological approach

As shown in Fig. 1, the proposed methodological approach consists of three main steps. All the stakeholders involved in the redevelopment process are identified in the first stage.

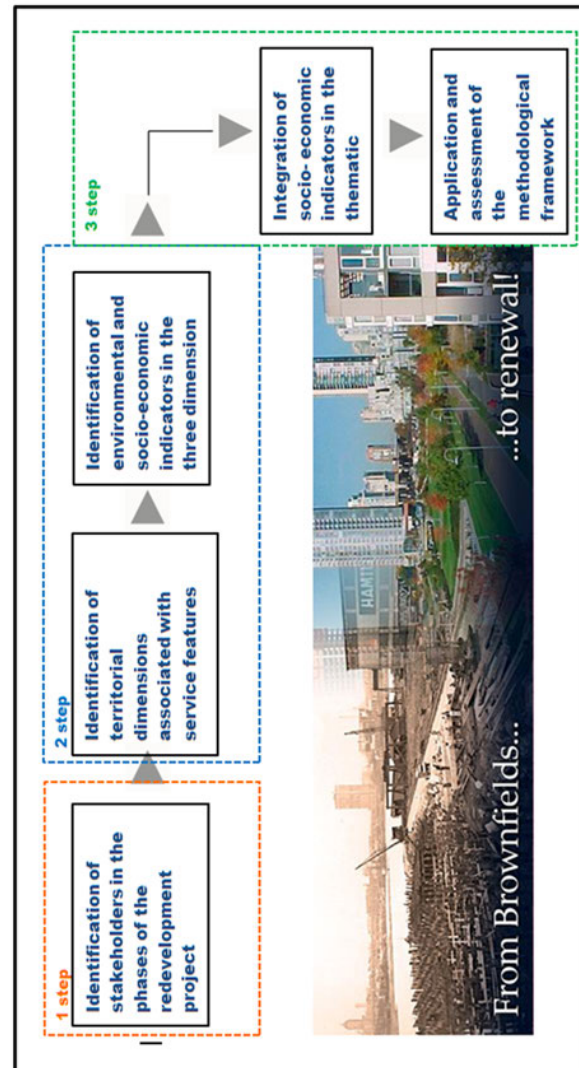

Fig. 1: Methodological approach for the evaluation of a project.

An inclusive vision of stakeholders is incorporated, considering a player as any stakeholder group or individual that is directly or indirectly influenced by the redevelopment process [Freeman, 1984; Mitchel et al., 1997 cited by 9]. In the second phase, the clusters of stakeholders are assembled in a common pattern by a transverse approach. We recognize the interrelationship between the themes in a field, and the various fields that connect the common themes. For example, steps to reduce the consumption of resources lead to reducing project costs, which is also a result of the promotion of sustainable lifestyles in terms of social consumption. This grouping makes it

possible to take into account the linkages and interdependencies between dimensions and themes. In the third step we classify all the themes that we believe are necessary for the redevelopment of a brownfield site. The purpose of this approach is to establish the level of complexity of the brownfield problem and also to form a structure of criteria with which to establish the actions to be taken to achieve the redevelopment. To proceed with the integration of aspects of sustainable urban development, the working method is to cross the dimensions with the project's parameters to translate the objectives for a project's development. From these crossings eight thematic fields will be selected in order to identify the issues to consider for successful integration. Table 4 shows the linking of eight thematic fields with the parameters of the redevelopment project. It is

assumed that between the themes and phases of project design, there are links to arrive at intelligent redevelopment objectives. For example, architectural heritage enhancement is related to urban form and to the historic preservation of buildings. There is also a link to the multi-functionality of services, the use of the territory and the social relations of citizens and economic activity at the industrial site.

The objective is therefore to contribute to brownfield redevelopment by transforming the traditional project criteria to support a sustainable redevelopment approach in which stakeholders use these criteria as the basis of communication with other stakeholders.

	<b>Thematic field</b>	<b>Redevelopment settings</b>
<b>Environmental valuation</b>	Natural Resource Management (Stormwater, sewage, alternative energy, etc.), biodiversity, quality of natural areas	Infrastructure system water; Water consumption (including water quality); Energy consumption; Green spaces; Water surface; Vegetation
	Environmental protection (floodplains, rivers, lakes, wetlands, parks, animals, etc.)	Use of space; Living areas; Landscape (unnatural barrier, bridges, viaducts); Enhancing biodiversity; Morphology; River system
	Improved comfort and health (pollution of the site )	Ventilation; Physical comfort; Proportion of own sites; Soil quality; Lighting
<b>social</b>	Strengthening cohesion and social equity	Accessibility; Public spaces; Density; Distribution services; Inclusion; Security
	Enhancement of the architectural (buildings and materials) and historical (preservation of historical memory) heritage	Structure; Materials; Technology; Protection; Care and maintenance; Form; Architectural fragmentation; Architectural quality
<b>Equitable value/social responsibility</b>	Cost reduction	Waste management; Distribution functions; Service – Business; Contiguity;
	Increase of cohesion (accessibility and transportation) and economic dynamics (employment and business)	Streets network; Public transport; Fluidity of movement; Parking; Links, connections; Economic diversification
	Multi-functionality of the territory, territorial competitiveness	Location; Connections; Partition areas; Urban form ( urban fabric ); Public areas; Historical activities
<b>Economic strategy</b>		

Table 4: Redevelopment settings.

The list of criteria is based on two groups of data: All the themes proposed for sustainable redevelopment early in our analysis were expressed as a set of criteria for the design of a sustainable industrial redevelopment (see Table 4). This was done to meet the goals (thematic). In

practice, by crossing each theme with each parameter we were able to establish the integration criteria. This was done with the intention to collect and consolidate criteria that meet different objectives with the parameters of design and also assemble the same practical criteria.

## 5 DISCUSSIONS

Thus far, the study has only revealed partial results, as there is not much specific literature that considers the tangible socio-economic aspects in brownfield development. Most studies that consider environmental issues prioritize soil contamination and decontamination. New criteria are essential for sustainable development solutions, and in this case, for the reuse of industrial sites. The tools used by professionals and municipalities have their shortcomings in terms of project evaluation. A tool must be able to clearly identify a project's objectives and to classify and prioritize them based on local interests. The need for regeneration of the natural environment, including the landscape and biodiversity, must be a priority [12]. The quality of brownfield conversion needs to consider users' expectations for the rehabilitation of these sites. We believe that the value of these sites and their re-appropriation for productive use must be taken into consideration. This can be attained through the use of suitable indicators. As stated by [Williams et Dair (2007) and Ballesteros et Ramirez (2007) cited from 9] attachment to cultural heritage must be among the objectives of redevelopment projects because of the influence of the concepts of landscape and the social aspects of the community. The indicators related to the conditions of public safety, accessibility, etc. also need to be part of the redevelopment of brownfields [6, 8, 9, 12]. A new methodological framework characterized by a multi-criteria, transversal and comprehensive approach is a requirement for moving towards sustainable redevelopment.

## 6 CONCLUSIONS AND FUTURE WORK

The sustainable development approach has led to a renewal of the conceptual issues of project development. The new criteria resulting from the crossing of thematic issues with the parameters of project design allow for better control of a project's implementation. These improvements are especially notable in the early stages of programming and project design. However, it is interesting to note that the success of such an approach in the context of a development project depends on the contributions of all of a project's stakeholders, and not only on national and local policy makers. This is clearly demonstrated in the results of our crossing the thematic issues with project parameters: project development criteria fail to address several issues that are required for a successful urban redevelopment. We prefer to leave the methodology open to supplementary and continuous evolutions. Without a proper system of checks and balances, the methodology will never improve. Checks and balances are necessary to validate the developed tools.

## 7 ACKNOWLEDGMENTS

We thank all the stakeholders that contributed with their knowledge, time and ideas to this study. We would also like to acknowledge Claudiane Ouellet-Plamondon and Conrad Boton for their incisive comments on the text.

Finally, we are grateful to the two anonymous referees for their thoughtful observations.

## 8 REFERENCES

1. <http://www.census.gov/> (visited page 14.12.2015)
2. Chen, Y., et al., *A strategic classification support system for brownfield redevelopment*. Environmental Modelling & Software, 2009. **24**(5): p. 647-654.
3. <http://www.unep.org/annualreport/2014/en/index.html> (visited page 13.12.2015)
4. Bartke, S. and R. Schwarze, *No perfect tools: Trade-offs of sustainability principles and user requirements in designing support tools for land-use decisions between greenfields and brownfields*. Journal of Environmental Management, 2015. **153**: p. 11-24.
5. Thomas, M.R., *A Weighted, Multi-Attribute, Site Prioritization and Selection Process for Brownfield Redevelopment*. Environmental Practice, 2002. **4**(02): p. 95-106.
6. Thomas, M.R., *A GIS-based decision support system for brownfield redevelopment*. Landscape and Urban Planning, 2002. **58**(1): p. 7-23.
7. Bramley, G. and S. Power, *Urban Form and Social Sustainability: The Role of Density and Housing Type*. Environment and Planning B: Planning and Design, 2009. **36**(1): p. 30-48.
8. Padiaditi, K., K.J. Doick, and A.J. Moffat, *Monitoring and evaluation practice for brownfield, regeneration to greenspace initiatives: A meta-evaluation of assessment and monitoring tools*. Landscape and Urban Planning, 2010. **97**(1): p. 22-36.
9. Sardinha, I.D., D. Craveiro, and S. Milheiras, *A sustainability framework for redevelopment of rural brownfields: stakeholder participation at SÃO DOMINGOS mine, Portugal*. Journal of Cleaner Production, 2013. **57**: p. 200-208.
10. Moussiopoulos, N., et al., *Environmental, social and economic information management for the evaluation of sustainability in urban areas: A system of indicators for Thessaloniki, Greece*. Cities, 2010. **27**(5): p. 377-384.
11. Sharifi, A. and A. Murayama, *Neighborhood sustainability assessment in action: Cross-evaluation of three assessment*



*systems and their cases from the US, the UK, and Japan.* Building and Environment, 2014. **72**: p. 243-258.

<http://www.usgbc.org/guide/nd> (visited page 03.12.2015)

12. Schädler, S., et al., *Designing sustainable and economically attractive brownfield revitalization options using an integrated assessment model.* Journal of Environmental Management, 2011. **92**(3): p. 827-837.

13. Nijkamp, P., C.A. Rodenburg, and A.J. Wagtendonk, *Success factors for sustainable urban brownfield development: A comparative case study approach to polluted sites.* Ecological Economics, 2002. **40**(2): p. 235-252.

14. Doick, K.J., et al., *Understanding success in the context of brownfield greening projects: The requirement for outcome evaluation in urban greenspace success assessment.* Urban Forestry & Urban Greening, 2009. **8**(3): p. 163-178.

15. Cohen, A., *Achieving Healthy School Siting and Planning Policies: Understanding Shared Concerns of Environmental Planners, Public Health Professionals, and Educators.* NEW SOLUTIONS: A Journal of Environmental and Occupational Health Policy, 2010. **20**(1): p. 49-72.

16. Chrysochoou, M., et al., *A GIS and indexing scheme to screen brownfields for area-wide redevelopment planning.* Landscape and Urban Planning, 2012. **105**(3): p. 187-198.

17. Chrysochoou, M., et al., *Reversing urban sprawl: A reclaimability index approach for reviving downtown Brownfields.* No. CTLS, 2011: p. 08-03.

18. Cappuyns, V. and B. Kessen, *Evaluation of the environmental impact of Brownfield remediation options: comparison of two life cycle assessment-based evaluation tools.* Environmental Technology, 2012. **33**(21): p. 2447-2459.

19. Luederitz, C., D.J. Lang, and H. Von Wehrden, *A systematic review of guiding principles for sustainable urban neighborhood development.* Landscape and Urban Planning, 2013. **118**: p. 40-52.

20. Greenberg, M. and M.J. Lewis, *Brownfields Redevelopment, Preferences and Public Involvement: A Case Study of an Ethnically Mixed Neighbourhood.* Urban Studies, 2000. **37**(13): p. 2501-2514.

21. De Sousa, C.A., *Turning brownfields into green space in the City of Toronto.* Landscape and Urban Planning, 2003. **62**(4): p. 181-198.

22. Wedding, G.C. and D. Crawford-Brown, *Measuring site-level success in brownfield redevelopments: A focus on sustainability and green building.* Journal of Environmental Management, 2007. **85**(2): p. 483-495.

23. Brill, C.W., *using GIS to contrast perceived versus preferred priorities for Brownfield redevelopment in worcester, massachusetts.* URISA Journal, 2009. **21**(2): p. 49.

24. Rall, E.L. and D. Haase, *Creative intervention in a dynamic city: A sustainability assessment of an interim use strategy for brownfields in Leipzig, Germany.* Landscape and Urban Planning, 2011. **100**(3): p. 189-201.

25. Yu, S., et al., *Allocating risk capital for a brownfields redevelopment project under hydrogeological and financial uncertainty.* Journal of Environmental Management, 2012. **100**: p. 96-108.

26. Beekmans, J., et al., *Countering decline of industrial sites: Do local economic development policies target the neediest places?* Urban Studies, 2015.





## Expanding Boundaries: Systems Thinking for the Built Environment

### SURVEY TOOL FOR THE BUILT ENVIRONMENT

H. Leindecker<sup>1\*</sup>, D. Mittermaier<sup>2</sup>

<sup>1</sup> FH OÖ Studienbetriebs GmbH, Stelzhamerstraße 23, 4600 Wels, Austria

<sup>2</sup> FH OÖ F&E GmbH, Franz-Fritsch-Straße 11 / TOP 3, 4600 Wels, Austria

\*Corresponding author; e-mail: herbert.leindecker@fh-wels.at

#### Abstract

The growing market share of building automation systems bears huge potentials in terms of energy savings and creates the opportunity to support its users in everyday life. Due to the direct impact on the building's residents, workforce, etc. the achievements and effectivity are highly dependent on the system user's satisfaction. The quantification of the rate of satisfaction has to be determined in cooperation with the affected parties, which can prove difficult without the suitable measures. In order to achieve this task, the online survey tool MOFNUG, developed by four Austrian Universities of Applied Sciences, provides novel approaches in terms of measuring the satisfaction of users regarding thermal comfort, indoor air quality, controllability of technology and various other building and user-related fields. Ideally, the questionnaire's evaluation should be complemented by measurement methods to establish relations between the proponent's subjective impressions and the variables of the area of interest.

#### Keywords:

Survey tool; User satisfaction; Building automation

## 1 INTRODUCTION

To fulfil the requirements of a sustainable and optimized building ("High Performance Building"), it is necessary to take into account user satisfaction, the highest and most difficult objective to be achieved in the planning and operation of buildings [1]. This principle also applies to the progressive automation of building systems aiming to enhance user convenience and comfort.

In this context the question arises, if these automated processes are accepted by the users as an increase in terms of comfort and if they appreciate the reduced amount of user intervention and which tasks shall stay manually operated.

As a consequence of the difficulties to quantify the vast range of factors influencing user satisfaction, a FFG-research project called MOFNUG („MOdularer Fragenkatalog für die NUTzerInnenzufriedenheit in Gebäuden") was introduced. The MOFNUG-project is a collaboration of four Austrian Universities of Applied Sciences with different perspectives in the spectrum of marketing, psychology, energy

engineering or facility management. Right from the beginning in 2013 the main focus in the ongoing cooperation was on the development of an online survey platform, serving as an adequate "measurement tool" for user satisfaction.

This tool and its modules are designed to react flexibly to various conditions, such as different types of buildings or user-structures. A basic module ("cluster") therefore deals with the building and subsequently also with the building automation. Other additional modules are in progress or in the planning phase.

The online surveys should ideally be accompanied by research methods and measurements (e.g. indoor air-measurements) based on the "Toolbox" work-in-progress.

## 2 DATA AND METHODS

After detailed basis research on the topic thermal comfort, which has been verified by our own practical measurements, simulations and surveys, the MOFNUG-tool was optimized [1], the literature research has been extended and

additional modules, processed by the research partners, have been integrated, such as the acoustic comfort and the visual comfort.

These modules form an important basis regarding the aspects of building automation, e.g. in order to achieve a high visual comfort it is necessary to create balanced lighting conditions with minimal disruption and to individually adapt the lighting according to the user's requirements.

### 2.1 Basics of building automation

Building automation should offer an opportunity to improve energy efficiency in new buildings, renovation or expansion of existing constructions and to obtain higher comfort levels for the building's users in parallel. Additionally, automated building services provide the foundation for enhanced security systems and are able to unite multimedia applications in a central control unit.

Besides, the substantial normative basis for thermal comfort (ÖNORM EN ISO 7730) and the general user satisfaction (ÖNORM EN 15252), the ÖNORM EN 15232 "Energy performance of buildings – Impact of building automation and building management" is identified as fundamental in the matter of building automation.

This standard assigns buildings unambiguous to energy efficiency classes. The classes range from "A" to "D", where "A" describes highly efficient, "B" advanced, "C" standard and "D" inefficient building automation systems, e.g. a building with the classification "D" lacks networked building automation functions, electronic room automation and energy monitoring. Fig. 1 indicates the discussed classes [2].

However, the problems of building automation are additional acquisition costs and the often limited possibilities regarding a building's expansion or renovation. Consequently, amortisation calculations result in extended long periods of time. Thus, economic considerations like savings due to increased energy efficiency, rarely are the sole argument for automation. Therefore, it is crucial to fulfil several functions simultaneously and to increase the satisfaction of users with the building and its systems in any case.

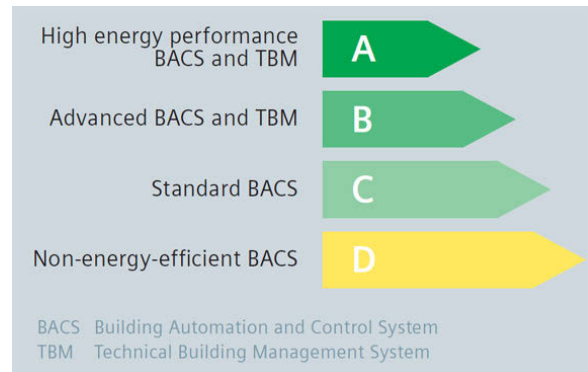

Fig. 1: BACS energy performance classes - BS EN 15232 [3].

### 2.2 Fundamental functions

This chapter contains a listing with an excerpt of the most important functions achieved with a building automation system. In order to specifically enhance user satisfaction, manufacturers developed integrated comfort functions in their products:

- Automatic or scheduled functions such as automatic wake up lights, timed door locks, automatic shutdown of consumers
- Window functions and control of awnings or blinds
- Heating set point reduction

Additionally, building automation systems allow the integration of security applications, figures of opportunities constantly rising:

- Intrusion detection
- Consumption / switching status monitoring
- Smoke / fire alarm
- Monitoring of power circuit, water pipes, overheating

The potential for increasing energy efficiency is an essential part of building automation, as suggested in EN 15232 (referring to chapter 2.1). Energy conservation is probably one of the most crucial points regarding the system's promotion, since these functions can directly reduce costs:

- (Intelligent) smart metering
- Heating and air conditioning control
- Energy management and consulting

Furthermore, multimedia features can be added among the previously mentioned opportunities. However, these functions require displays, panels or compatible operating systems to communicate with the automation system:

- Audio Integration
- Visualization of images and videos
- Internet integration

In addition, there are document management capabilities enabling centralized data storage, the personalized and situation dependent output of data and various other functions. Remote access to a centralized system without programming

skills is established by content management systems [4].

### 2.3 Energy savings

Becker and Knoll conducted a comprehensive literature research and an experimental study at the Hochschule Biberach. The results of the literature research are shown in Fig. 2, relying on 117 sources. The numbers in the brackets describe the underlying amount of sources per category. Note the part-wise relatively large bandwidths due to differently defined functionalities and combined measures [5].

The lighting (E), energy management (I), ventilation (G) and general functions (A) hold the biggest potentials for energy savings. Other trades like sun shading (B), heating (C), the optimisation of controls (D), energy efficient devices (F) and cooling (H) bear lower potential to conserve energy.

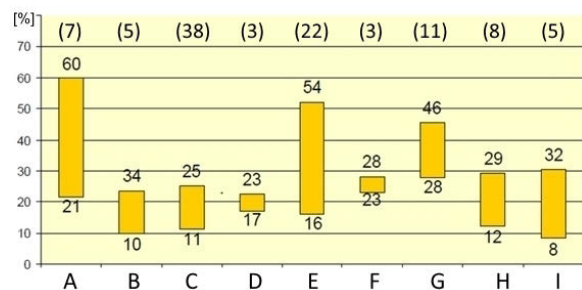

Fig. 2: The theoretical potentials for savings of Building automation [5].

Partly considerable savings are one reason for the automation of energy-intensive trades and they allow justification for potentially higher installation, acquisition or cleaning costs of a building.

Under the direction of Christian Struck a preliminary study with literature reviews and surveys has been executed in order to gain knowledge regarding the energy-saving potential by building automation [6].

The calculated energy saving potential evidenced that beside the applied technologies, there is a heavy dependence on the type of building. The savings potential is indicated by 49% in shopping centres, 39% in office buildings, 27% in residential buildings and 18% in hospitals. The values were determined by calculations with the TRNSYS building simulation software.

The theoretical saving potential is also heavily influenced by users. They have to be able to deal with the installed systems and its manual control units and be prepared for their influence.

### 2.4 Customer acceptance

Professor Michael Krödel from the University of Rosenheim concentrates his work on building automation and technology. As part of this activity, studies dealing with the topic of consumer acceptance were supervised by him.

His studies discuss on the one hand, which automatism or manual intervention is required and on the other hand, which one is unnecessary or useless.

The analysis of the replies to a survey among potential building automation users younger than 30 years derived from his paper shows rather surprising results: the remote access function has a low acceptance rate, although the participants belong to the smartphone generation. The focus was on energy efficiency established by individual room management as well as some security and comfort functions. The highest acceptance among the research group was accomplished by a centralised "shut off everything" button and networked smoke detectors, followed by room temperature control, automated blinds and malfunction detection [7].

### 2.5 Needs and desires

Besides the technical feasibility of the automated trades the desires and needs of users, suppliers and manufacturers also have to be taken into account.

The extension of independent living is one of the most promising aspects for users and manufacturers as well if the foundation beneath the system is sophisticated and barrier-free. Furthermore, the data exchange with nursing homes and health surveillance is of high relevance among users and can be associated with the previous aspect.

Beside these functions regarding health and age assisted living, suppliers and manufacturers have to fulfil the user's desire for individualisation, interactivity and multi-device-consumption [8].

Nevertheless, it has to be bared in mind that these applications have to be energy efficient and reasonably priced in order to achieve sustainability and generate a high market share.

Not only the technology itself but also its usefulness decides whether new systems are accepted or not. Security and safety, comfort and economic considerations significantly influence the user's decisions. Providers of products and services have to handle these requirements [8]:

(i) Increase in safety and security terms:

- Safety functions for people and environment
- Denial of unauthorised data access and manipulation
- Secure operation of the provided infrastructure, fault-tolerant systems, plausibility checks, integrated hazard prevention, technical safety
- Protection of privacy (e.g. video surveillance)
- Reliable and plausible confirmation of remote operation
- Fast and guaranteed error diagnostics and troubleshooting (online service)
-

## (ii) Comfort enhancement:

- Preserve independence of lifestyle (e.g. handicaps, age-related constrained motivity)
- Information and communication technologies should work discretely in the background (important for specific target groups)
- Controllability of the technology, possibility of intervention at any time
- High integration rate (useful and comprehensible connection of services)
- Logical memorability of the service (e.g. intelligent heating)
- Multifunctionality of physical user interfaces (e.g. universal remote)
- Ease of use (“universal design”)

## (iii) Inexpensive application:

- Low initial costs, high flexibility and upgradeability
- Acceptable price in proportion to the difficult to quantify benefit convenience functions
- Expendability in dependence of user requirements and financial framework conditions (“hot plug & play”)

### 3 RESULTS

This chapter focuses on the current status of the online questionnaire in the MOFNUG-project. The expansion regarding building automation took place primarily in the cluster 15 “Controllability of technology”.

#### 3.1 Module of questionnaire “Controllability of technology”

The questions of this cluster are mostly consisting of the question type “7-Point Custom Label Likert Scale”. This type has seven possible answers, wherein the first and the last (seventh) point are occupied by the conflicting answers (labels are set). The respondent can choose between the clear-cut answers or his perceived reduction, whereby the strength of discomfort can be illustrated. Here are some examples from the questionnaire:

The following trades of the building are controlled automatically (Selection: heating, cooling, ventilation, lighting, shading):

- Is it possible to control the blinds in larger rooms in groups to quickly achieve the desired shading conditions and to save time?
- Is it possible to control the lighting in larger rooms in groups to quickly achieve the desired lighting conditions and to save time?
- Which operating options do you have to change the indoor climate?
- How difficult is it for you to operate the various functions for temperature, shading, window and lighting control?

The questions were reviewed and supplemented by Zainer [9]. It should also be made a statement whether the indoor environment is maintained during the day and whether the users are generally satisfied with the automation.

- Is it ensured that in summer your selected indoor climate is maintained during your entire stay or do you need to adapt your inputs?
- Are the systems of the building emitting distracting noises?
- Which Building technology is automated to an unnecessary level, should therefore be better user controlled than automatically?

In an extended part of the question modules it is all about whether or not the users unknowingly contribute to conserve energy, which is established by Building automation in conjunction with energy metering.

- Do you save energy intentionally (e.g. by switching off redundant light sources, short/complete changes of air instead of permanently opened windows, etc.)?
- Are you aware of your personal energy consumption?
- Are there motion sensors in use at your workplace to switch of power when absent?
- Does your office have a central switch to power off all devices at the end of your working hours?

The questions provide explanations that can be accessed by the respondent wherever decisive. The aim of the questionnaire creator should be to select only as many questions as necessary for significant results [9].

#### 3.2 Conducted surveys

Two major surveys took place in pursuance to test the MOFNUG-tool and to acquire information provided by experts as well as layman.

The “Gebäudeintegrierte Photovoltaik” (“Building integrated photovoltaics”) survey targeted to gain new insights from BIPV business insiders and the “Gebäudeautomation an der FH Wels – Wie zufrieden sind Sie?” (“Building automation at the University of Applied Sciences Wels – Are you satisfied?”) survey investigated the satisfaction of the employees regarding the automation systems in their activity area.

The conclusion of these surveys will be presented at the SBE conference 2016.

### 4 DISCUSSION

For the creation of a survey it is crucial to have knowledge regarding the building, its automation systems and occupants. It should be differentiated whether the respondents are layman or experts in the assessed technical issues and subsequently to create varying surveys.

This basic information lays the foundation for the creation of a questionnaire. With the credentials to access the website you have the opportunity to set it up, deliver it digital or analogue and finally evaluate the replies of the proponents.

The MOFNUG-tool provides the possibilities to create and adapt surveys in a flexible and

accessible way and is able to generate evaluations of the responses automatically. The question data base is permanently expanding resulting in a large scope of application. The screenshot in Fig. 3 is exemplary for the design and structure of the MOFNUG-platform.

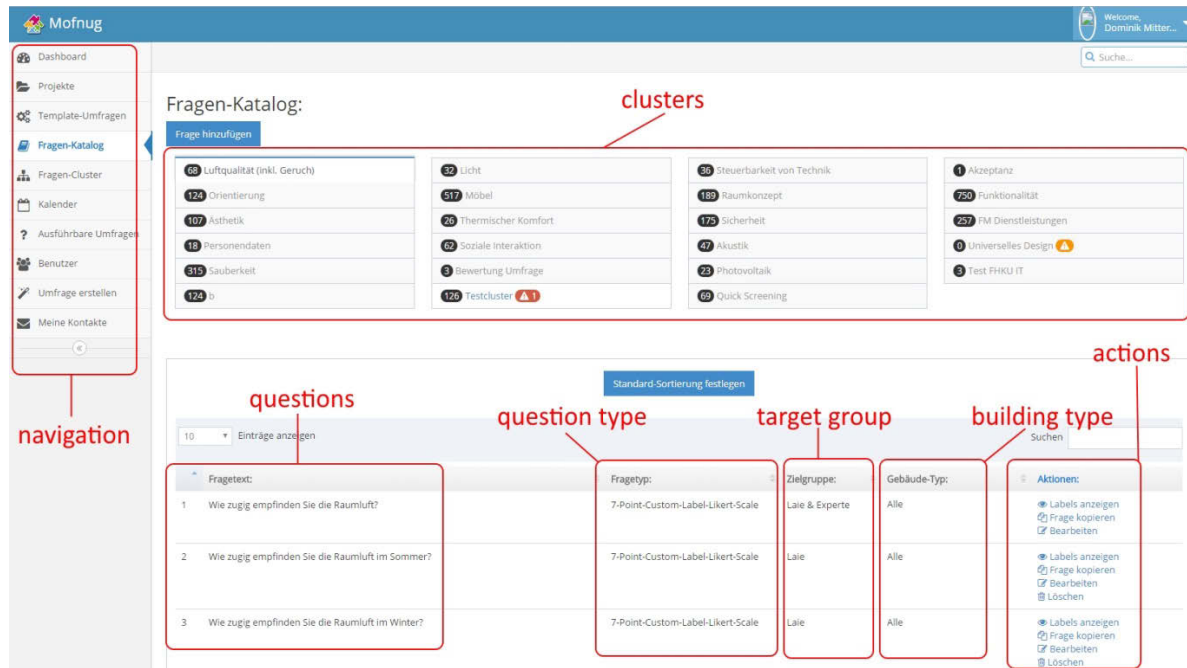

Fig. 3: Showcase for the MOFNUG-tool with explanations (red) [10].

## 5 CONCLUSION

As the subject of this study includes several equally important areas of construction technology, an extensive basic research was necessary, although there is still a lack of substantial studies. The technical possibilities in the building automation sector implied that they are properly implemented, can be a major contribution to the improvement of the energy performance of buildings.

EU norms and governmental regulations provide a healthy basis for the decision and therefore the investment in a building automation system, especially for non-residential buildings. Companies are encouraged in the form of subsidies or tax reductions to increase investments, finally resulting in lower life cycle costs and benefits for the environment.

The difficulties of building automation are based on the interference of systems due to the various comfort and energy saving functions and their mutual interaction. The integral planning approach suggests that building automation has to be discussed among experts and the later users in the earliest possible design stage (depending on building type).

Furthermore, the important aspect of automation beyond necessity has to be taken into account. A

technical system is only satisfactory if it is working properly. Too many features and automated trades often result in a reduction of user satisfaction. Users attach great importance to the fact that windows and doors can be handled manually and the possibility to adapt sun shades and alter the temperature independently.

The research project MOFNUG offers the opportunity to the involved parties to modularly tailor questionnaires on the subject's requirements. The integration of measuring instruments allows a comparison of the knowledge obtained by the surveys with precise measurement data. Thus, an optimized quality of buildings can be realised more easily. The aim is that future buildings have the least possible environmental impact and are able to adapt to external conditions quickly, without interfering with the building's users and simultaneously save energy. With careful planning and execution this is already possible today.

## 6 REFERENCES

1. Leindecker H.C. & Dornigg I., NutzerInnenzufriedenheit in nachhaltigen Gebäuden. In: Nachhaltige Gebäude. Versorgung – Nutzung – Integration. Tagungsband e-nova 2014, Internationaler Kongress 13.-14. November 2014. University of Applied Sciences Burgenland. Department Energie- und Umweltmanagement (Hrsg.). 2014: Pinkafeld, Austria
2. ÖNORM EN 15232 Energieeffizienz von Gebäuden – Einfluss von Gebäudeautomation und Gebäudemanagement. Österreichisches Normungsinstitut. 2012: Wien, Austria
3. KNX, KNX Helps Achieve Class A Building Performance of BS EN 15232, <http://knxtoday.com/2013/05/1156/knx-helps-achieve-class-a-building-performance-of-bs-en-15232.html>. Date of access: 14.01.2016
4. Aschendorf, B., Energiemanagement durch Gebäudeautomation. Springer Verlag. 2014: Wiesbaden, Germany
5. Becker, M. and Knoll, P., Kurzzusammenfassung zu Projektvorhaben Energieeffizienz durch Gebäudeautomation mit Bezug zur DIN V 18599 und DIN EN 15232. Department: Institut für Gebäude- und Energiesysteme, Hochschule Biberach. 2011: Biberach, Germany
6. Struck, C., et al., Energieeinsparpotential durch Gebäudeautomation und energetisches Gebäudemanagement. 16. Statusseminar ETH Zürich. 2010: Zürich, Switzerland
7. Krödel M., Was will mein Kunde wirklich? Kundenanalysen und Umfragen zur Raumautomation. BUSSYSTEME magazine, Issue 3, p. 158/159. 2013: Berlin, Germany
8. Strese et al., Smart Home in Deutschland, Hartmut Strese, Uwe Seidel, Thorsten Knappe, Alfons Botthof, Department: Institut für Innovation und Technik. 2010: Berlin, Germany
9. Zainer, S., Auswirkungen von Gebäudeautomation auf Energieeffizienz und NutzerInnenzufriedenheit. Bachelor thesis, FH Upper Austria/Campus Wels. 2015: Wels, Austria.
10. MOFNUG (MODularer Fragenkatalog für die NutzerInnenzufriedenheit in Gebäuden), online survey tool, <http://mofnuglive.web-fhku.eu/question>. Date of access: 14.01.2016



Zurich, June 15-17 2016  
Sustainable Built Environment (SBE) Regional Conference

Expanding Boundaries:  
Systems Thinking for the Built Environment



## BIO-BASED PLASTICS-COMPOSITES FOR SUSTAINABLE BUILDING SKINS: LIFE EXPECTANCY OF CLADDING DERIVED FROM WIND SUCTION TESTS

D. Friedrich<sup>1\*</sup>, A. Luible<sup>2</sup>

<sup>1,2</sup>Lucerne University of Applied Sciences - Engineering & Architecture  
Competence Center Façade and Metal Works  
Technikumstrasse 21, 6048 Luzern-Horw, Switzerland  
\*Corresponding author; e-mail: daniel.friedrich@hslu.ch

### Abstract

Wood-plastics composites (WPC) consist of wood fibres embedded in a matrix made from petrochemical or bio-based polymers. Cladding produced from such green plastics is considered to be more ecological than current PVC panels. Its sustainability as a building product can be assessed with life cycle assessments. Life cycle analysis, however, requires reliable data about the life expectancy of the WPC façade. It is commonly assumed that if the structural resistance of cladding is shown to resist the wind loads given in the standards, long-lasting performance is guaranteed. Currently, the suitability of using WPC cladding in façades is judged merely by the bending strength and modulus of elasticity of a single cladding panel. Whether these parameters can indeed be used to design the entire façade has never been examined. In this study, the structural capacity of WPC façade elements was investigated with wind suction tests. It was found that WPC façade elements possess a structural resistance that is adequate for wind loads for Central Europe given in the relevant standards, which is an indication of their durability. The basic failure mode observed in the tests was not bending failure of the cladding panel, as expected, but pull-out failure of the fasteners or edge failure. The life expectancy of a WPC cladding panel is therefore governed by the mechanical strength of its connections. Hence, it is recommended that façade planners select WPC products based on the design strength of the fixation mechanism rather than on bending resistance of the cladding panels.

### Keywords:

Bio-based plastics; cladding; wind resistance; simulated wind suction; basic failure mode

## 1 INTRODUCTION

Wood-plastic composites (WPCs) represent a new generation of bio-based materials. They consist of a plastics matrix incorporating bio fibres, such as wood or grass. The European market for WPC used in constructions is expected to increase to 450,000 t in 2020. The highest growth rates are in the area of decking, which in 2012 made up 67% of the WPC products in Europe. WPC cladding only amounted to 6.1% of the total in 2012 [1,2].

Polypropylene (PP), polyethylene (PE) or polyvinylchloride (PVC) is used for the matrix of WPCs, partly as recycling granulate [3]. These bulk plas-

tics, however, are produced from scarce fossil resources. Recent developments include attempts to produce matrices from polymerized corn starch, such as polylactides (PLA). Products made from PLA could theoretically be biodegradable and used for composting [4,5].

As far as the material is concerned, green-composite façades (GCFs) certainly show great promise for use in future buildings. The global warming potential of PLA, for example, is 30 times less than that of bulk plastics [6,7]. A life cycle assessment (LCA) could easily show that a GCF product is the best alternative to competing conventional materials. However, considerations should include the complete product life cycle, as

a short life expectancy distorts the results of life cycle assessments [8,9]. Also, PLA is far more costly than traditional products, resulting in an expensive investment for house owners. However, the ecological product attributes can, to a certain extent, compensate for the higher prices and lower durability [10].

The development of bio-based plastics cladding requires investigations of the technical, ecological, economic and social product attributes. Life cycle sustainability assessments are an accepted way of quantifying such attributes for a given life expectancy. It does appear that the durability of a product plays a key role, but it is difficult to estimate its life span prior to development. Regarding standards and codes, Regulation (EU) No. 305/2011 [11] stipulates that products must meet the requirements for mechanical resistance and stability, as well as safety. These requirements are formulated as verifications of limit states according to EN 1990 (EUROCODE 1) [12]. When developing WPC cladding, it is therefore essential to make sure that the structural resistance matches the design loads stipulated in the relevant standards, thus ensuring that the product will perform adequately under wind loads. It is also important to note that the wind loads given in EUROCODE 1 are 50-year wind loads representing an extreme event that will statistically occur once every 50 years [13]. The underlying philosophy is that compliance with this standard ensures structural health for at least this time span, leading to more reliable life cycle analyses over the entire design life.

New WPC cladding products with bio-polymer matrices should be consistent with conventional WPC regarding technical performance [14]. By doing so, green-composite cladding would add value at least with respect to environmental friendliness. In past research it was observed that very few tests of WPC cladding have been carried out so far [15]. This study is the first to assess the life expectancy of WPC cladding based on its structural capacity under realistic conditions. In particular, the wind suction resistance of a façade section is investigated. From the results it is concluded whether existing WPCs can resist the design loads stipulated in the relevant standards and hence represent the state of the art. Findings will serve as the basis for the development of future green-composite façades by acting as a reference in comparative studies. Finally, results from this study will provide penetrating insights into realistic façade design with current WPC cladding.

## 2 MATERIALS AND METHOD

### 2.1 Characterization of the materials

In this study, only commercially available and randomly selected products were used. Specimens were made from two types of WPC con-

taining bamboo wood flour (WF) embedded in a thermoplastics matrix. The product-related data were collected from manufacturers' specifications. Product 1 was a polymer composite containing recycled high-density polyethylene (HDPE). The ratio of WF to PE was 60:30, and about 10% of additives (pigments and compatibilizer) were added. The moment of inertia ( $I_y$ ) was 63,606.5 mm<sup>4</sup>.

Product 2 was a WPC made from high-density polypropylene. The fibre ratio of WF to PP was 70:30. The thermoplastics matrix also contained additives. The moment of inertia  $I_y$  was calculated to be 87,516.5 mm<sup>4</sup>.

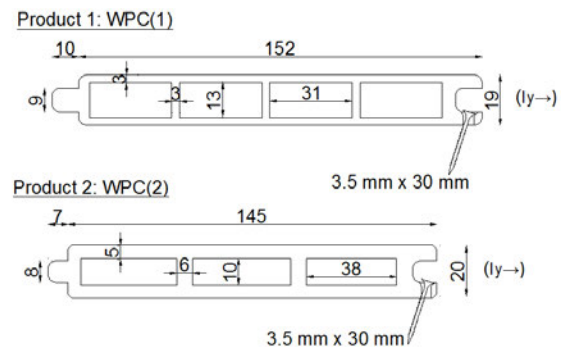

Fig. 1: Dimensions of tested cladding profiles.

Both types of WPC showed similarities with respect to dimensions (Figure 1), type of plastics and fibre components. Product 2 mainly differed in the proportion of fibres and wall thickness of the hollow profile. Modulus of elasticity (MOE) for both products was determined with the same apparatus described in Section 2.2. Force  $q$  [N/mm<sup>2</sup>] was applied to a single span ( $e = 1100$  mm) consisting of two panels with a tongue-and-groove connection. The non-standardized MOE was calculated as follows:

$$\text{MOE [N/mm}^2\text{]} = (5 \cdot Q \cdot e^4) / (384 \cdot I_y \cdot f), \quad (1)$$

where  $f$  is the deflection of the specimen [mm],  $I_y$  is the moment of inertia of the panel [mm<sup>4</sup>] and  $Q$  [N/mm] is the applied wind load calculated with the following formula:

$$Q \text{ [N/mm]} = q \cdot b, \quad (2)$$

where  $b$  [mm] is two times the width of the panel.

This testing procedure captured more realistically the behaviour of a complete façade than that of a single panel as is the case with the usual three-point bending tests. Overall, the MOE of both products were higher than those reported in literature, which might be due to the tongue-and-groove coupling effect. Product 2 was 60% stiffer than product 1 (Figure 2).

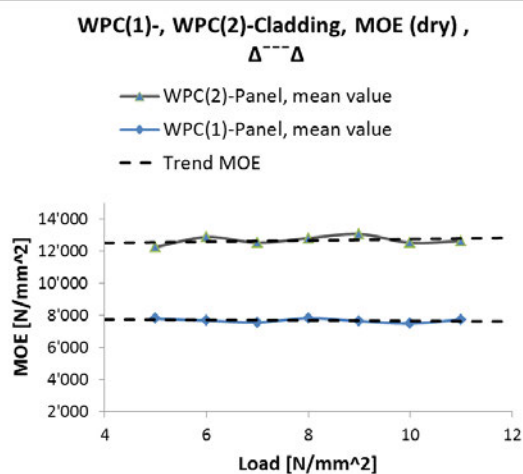

Fig. 2: MOE of tested WPC cladding.

## 2.2 Methodology

One of the primary goals of this study was to investigate the basic failure mode and wind suction resistance of two selected WPC profiles under service conditions as specified by their manufacturers. To obtain the most application-oriented results possible, large-scale façade sections were tested, which were built according to the respective manufacturer's installation manual. Each section had two spans and contained four individual panels which were interlocked by groove and tongue. At the points of attachment, 4 mm holes were drilled through the flanges of the panels to accommodate the dilatation of the matrix under a realistic temperature increase. The profiles were fixed to the timber sub-rails using 3.5 mm x 30 mm fillister head screws, which were placed at the centre of each long hole and tightened by hand. As both products had similar widths, the number of fixing points per  $m^2$  was the same for both.

As the panels were provided with groove and tongue, the building skin was considered to be

almost wind tight and the tests were carried out according to the European Technical Approval Guideline (ETAG) 034:2012 [16]. The test layout further followed the specifications of DIN 18516-1:2010 [17]. Both standards propose placing plastic foil bags at the rear of the cladding and inflating them with air until the panel fails. For the study at hand, two bags were installed in the 60 mm ventilation gap behind the panels (Figure 3). Deformation along the inflated bags was measured using mechanical sensors placed at the front of the panel at mid-span. The air pressure was produced by an 8-bar compressor. The air inflow to the bags was manually controlled by a throttle valve. The pressure was applied in steps of  $0.2 \text{ kN/m}^2$  and interrupted only for 30 seconds to record the deformation. Wind suction between  $0.4 \text{ kN/m}^2$  and  $12 \text{ kN/m}^2$  was thus simulated as stipulated by EUROCODE 1 [12] for Central European wind loads. A test ended when a panel failed or the upper load limit was reached. Tests were executed for spans given by the manufacturer's specifications which varied from 400 mm to 700 mm for Product 1, and 500 mm to 600 mm for Product 2 (Figure 4). Two tests were carried out for each span length.



Fig. 3: Plastic foil bags at the rear of the cladding.

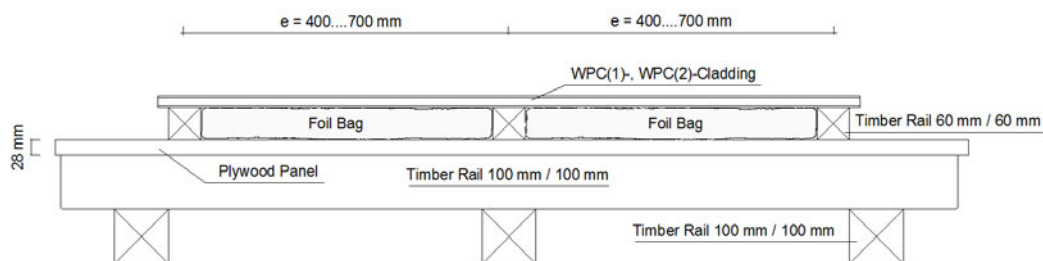

Fig. 4: Experiment setup showing the WPC specimen spanned over two fields.

## 3 RESULTS AND DISCUSSIONS

### 3.1 Basic failure mode

Twelve tests were run in total. Two thirds of the tests ended with failure of the façade section. The remaining tests were terminated when the upper load limit of  $12 \text{ kN/m}^2$  was reached. Surprisingly, the only observed failure modes were

pull-out failure of the screw at the panel flange and edge failure next to a screw. The connection of the panel therefore governed the basic failure mode of the tested specimens (Figure 5).

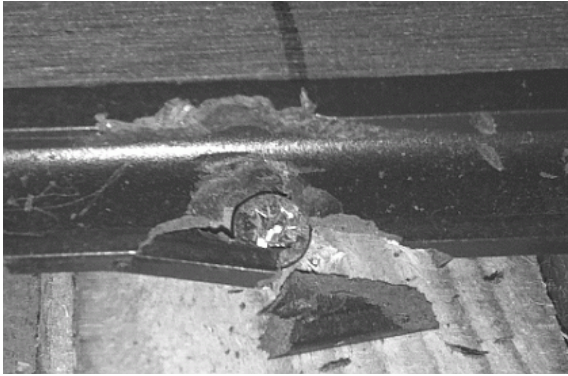

Fig. 5: Edge failure under wind suction.

### 3.2 Resistance to wind suction

Figure 6 lists the mean deflections of the panels with span  $e$  along the path of the applied wind load. Product 1 failed by connection failure, irrespective of span length and magnitude of wind load. The load curves are continuous and show an increase in deformation with increasing air pressure. The trend line illustrates the interdependence of span  $e$  and failure load  $F_{\text{mean},k}$ . As expected,  $F_{\text{mean},k}$  is inversely related to the span length. However, the curve does not decrease monotonically, because the results for both the 600 mm and 700 mm spans were the same. From Figure 6 it can be seen that Product 1 cannot withstand the wind loads stipulated in the standards. However, by reducing the distance between the sub-rails, the resistance of the façade can be increased. The specimens of Product 2 did not fail in any tests – they withstood all wind loads (Figure 7). As the tests stopped at the upper load limit, no trend line for failure of the façade segment could be drawn. However, as far as the objective of this study is concerned, these tests showed that even for Product 2 bending failure is not the basic failure mode under the wind loads stipulated by the relevant standards.

In Section 2.1 each tested product was characterized according to its MOE. It is commonly assumed that a higher modulus of elasticity means smaller deflection of the panel under wind suction. Product 2, which is 60% stiffer than Product 1, therefore deflected 4 to 5 times less than Product 1. Due to the small number of specimens, however, it could not be proven that the resistance of the fixing points increases with panel stiffness. To the authors' knowledge, WPC cladding manufacturers provide no test data of the screwed connections. Thus, not enough application-oriented design values for WPC façades are available, which could be used by façade planners to carry out the design checks for building projects. This might explain the lack of success of WPC cladding as opposed to WPC decking, which is subjected to point loads only, and bending failure hence governs. Providing design values for WPC cladding could go a long way

toward making this product more interesting to designers and builders.

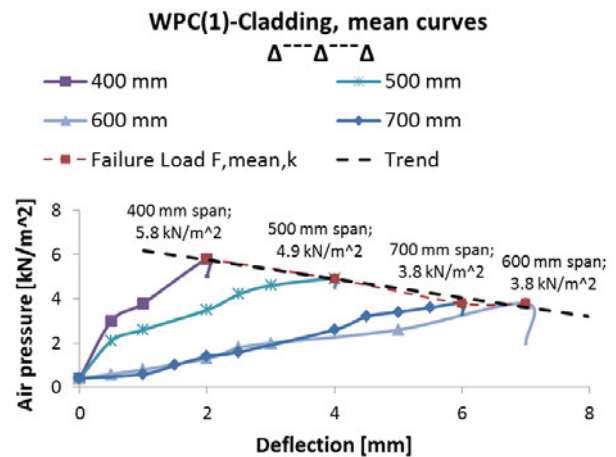

Fig. 6: Load curves of Product 1.

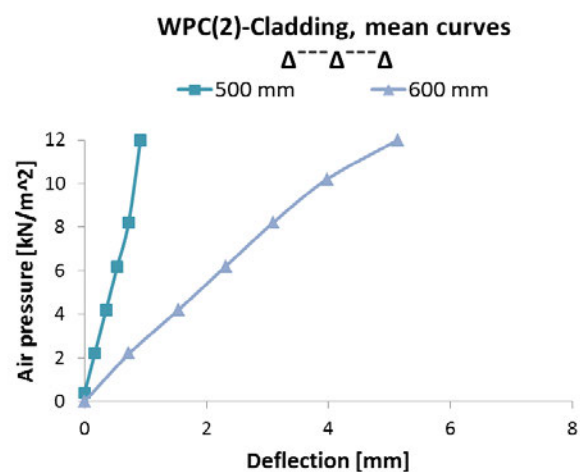

Fig. 7: Load curves of Product 2.

### 3.3 Life expectancy

It has been demonstrated that both tested products can resist particular design wind loads given in the standards. Hence, it can be concluded that they will perform their function in the long term, which includes resisting peak wind loads statistically occurring every 50 years. The results of a life cycle analysis could show that WPC cladding could indeed compete with current façade materials in terms of durability. However, in this study only specimens in their virgin state were tested. The strength of the material will probably deteriorate due to material degradation over the decades. As pull-out of the screw heads is the basic failure mode, it can be assumed that material degradation in the area of the fixings is much less pronounced than in the outer layer of the cladding, which is exposed to hazardous UV-radiation and humidity.

Such aging effects are usually covered by a conversion factor  $\eta$ , which translates characteristic

properties into design properties and reduces the design strength of the cladding or a single screw accordingly [12]. In preparation of this study, investigations showed that the aging coefficient for today's WPCs is about 2.0 [14]. If a safety factor  $\gamma$  of 2.0 is applied also, the design value for wind resistance of a WPC would be approximately 3–4 kN/m<sup>2</sup>, which is an acceptable value for most building projects.

### 3.4 Development constraints for future green-composite façades

The results from this study have managerial implications. With respect to the development of future green-composite façades, it is important to focus on the fastenings rather than on optimizing bending strength, which is usually the emphasis of basic WPC material research. It is therefore recommended to use cladding profiles with a bending resistance only slightly higher than the pull-out strength of the fasteners. By adding more material to the flange where the fasteners are located (Figure 1), and less to the profile walls, bending resistance is reduced, while the strength of the connection is increased. In this regard, the ETAG 034, chapter 5.4.2.4.1, suggests using small-scale cladding samples applied to a 50 mm ring where a screw head is either pushed or pulled through and the breaking loads are measured. These tests should be conducted prior to the large-scale foil bag test which then should verify whether the optimized profile geometry indeed provokes higher wind load resistance in practice. Such an approach renders the cladding product more sustainable and economical in terms of resource use and production costs.

## 4 SUMMARY

This paper deals with the compliance of current WPC cladding with design wind loads. Test results confirm that the investigated panels have sufficient structural capacity to resist the wind loads. As a consequence, the life expectancy for life cycle analyses can be derived from the statistical occurrence of the peak wind loads given in the relevant standards. However, whether the 50-year wind applies to WPC cladding strongly depends on additional aging effects during its lifetime. It can be argued that material degradation in the vicinity of the hidden fasteners of WPC cladding is much less pronounced than at the outer profile layer. Because of this fact and the results of this study, currently available WPC cladding can be assumed to have a long life span. However, further comparative studies should be carried out to confirm this assumption.

Finally, pull-out failure of the fasteners and edge failure at the connections have been shown to be the basic failure modes. This raises the question if today's WPC cladding products can be designed correctly by façade planners, as product

specifications solely focus on the modulus of elasticity and the bending strength. The presented findings support the recommendation that in the development of WPC cladding with either petrochemical or bio-based matrices the strength of the connection should be considered as the better predictor for structural capacity.

This study also has some limitations. The tested products represent a rather small number of WPCs, and the fact that only two tests were carried out for each product and span length weakens the statistical significance of the results. However, the large-scale foil bag test is arguably the most application-oriented test possible, which is why only so few tests were run in this study.

## REFERENCES

1. Carus M., Dammer, L., Scholz, L., Essel, R., Breitmayer, E., Eder, A., Korte, H., European and Global Markets 2012 and Future Trends. *bioplastics Magazine*, 2014. (9): p.42-44.
2. Eder A. and Carus M., *Global Trends in Wood-Plastic Composites (WPC)*. *bioplastics Magazine*, 2013. (8): p.16-17.
3. Carus, M., Müssig, J., Gahle, C., *Naturfaserverstärkte Kunststoffe – Pflanzen, Rohstoffe, Produkte (2008)*. Fachagentur Nachwachsende Rohstoffe e.V. (FNR): Gülzow-Prüzen.
4. Dahman, Y. and Ugwu, C., Production of green biodegradable plastics of poly(3-hydroxybutyrate) PHB from renewable resources of agricultural residues. *Bioprocess Biosystem Engineering*, 2014. (37): p.1561–1568.
5. Ferrero, B., Fombuena, V., Fenollar, O., Boronat, T., Balart, R., Development of Natural Fiber-Reinforced Plastics (NFRP) Based on Biobased Polyethylene and Waste Fibers from *Posidonia oceanica* Seaweed. *Polymer Composites*, 2014. DOI 10.1002/pc.23042.
6. Zini E. and Scandola M., *Green Composites: An Overview*. *Polymer Composites*, 2011. (32): p.1905–1915.
7. Essel, R. and Carus, M., *Meta-Analyse von Ökobilanzen für bio-basierte Polymere in der Produktion von Proganic (2012)*. nova-Institut GmbH: Hürth.
8. Jessada Boonniteewanicha, J., Pitivuta, S., Tongjoya, S., Lapnonkawowa, S., Suttiruengwong, S., Evaluation of Carbon Footprint of Bioplastic Straw compared to Petroleum based Straw Products, in *11th Eco-Energy and Materials Science and Engineering (11th EMSES)*. *Energy Procedia*, 2014. (56): p.518 – 524.
9. Guardiglia, L., Monaria, F., Bragadina, M., Assessing environmental impact of green buildings through LCA methods: a comparison between reinforced concrete and wood structures

in the European context, in *Procedia Engineering*, 2011. 21: p.1199 – 1206.

10. Osburg V., Strack M., Toporowski W., Consumer acceptance of Wood-Polymer Composites: a conjoint analytical approach with a focus on innovative and environmentally concerned consumers. *Journal of Cleaner Production*, 2015. p. 1-11.

11. Regulation (EU) No 305/2011 of the European Parliament and of the Council laying down harmonized conditions for the marketing of construction products and repealing Council Directive 89/106/EEC.

12. DIN EN 1990:2002, EUROCODE 1, Basis of structural design, ISC91.010.30.

13. Grünberg, J., Grundlagen der Tragwerksplanung – Sicherheitskonzept und Bemessungsregeln für den konstruktiven Ingenieurbau. 2004, Beuth Verlag.

14. Friedrich D. and Luible A., Biodegradable future building skins, in 10th Conference on Advanced Building Skins. 2015: Bern, Switzerland. p.1484-1493.

15. Friedrich D. and Luible A., Supporting the development process for building products by the use of research portfolio analysis: a case study for Wood Plastics Composite materials. *Case Studies in Construction Materials*, 2015: <http://dx.doi.org/10.1016/j.cscm.2015.12.003>.

16. ETAG 034 Edition July 2011, Guideline for European Technical Approval of Cladding Kits for External Wall Claddings, Part 1: Ventilated Cladding Kits Comprising Cladding Components and Associated Fixings.

17. DIN 18516-1:2010-06. Cladding for external walls, ventilated at rear - Part 1: Requirements, principles of testing.



## Expanding Boundaries: Systems Thinking for the Built Environment

### HOLISTIC OBSERVATIONS ON THE SUSTAINABILITY OF HIGH-RISE BUILDING FAÇADES

M. King<sup>1\*</sup>, D. Geissbühler<sup>1</sup>, U. Menti<sup>2</sup>

<sup>1</sup> Research Group Materials and Structure in Architecture  
Lucerne University of Applied Sciences and Arts - Engineering & Architecture

Technikumstrasse 21, 6048 Horw, Switzerland

<sup>2</sup> Center for Integrated Building Technology

\*Corresponding author; e-mail: marvin.king@hslu.ch

#### Abstract

High-rise buildings are currently experiencing a renaissance in Switzerland. The building element with the largest surface area of this omnipresent building type is its envelope, which on average makes up 20-25% of overall construction costs. At that complex interface between the interior and exterior, almost all planning parameters meet with constantly growing demands. Based on 14 current high-rise façades, an interdisciplinary research team from the HSLU T&A [1] developed content-based principles for a decision making instrument [2]. The CTI-Project "Building Envelope" focuses on the following question: Which decisions are made by an investor in early conceptual and planning phases when it orders a sustainable building envelope for a high-rise building, and which effects do those decisions have on the economy, ecology and society? The project generates and communicates knowledge of the highly complex connections and interactions in producing a building envelope for multi-storey buildings. Available analysis data in the system of the EAK/OAK [3.] allows its direct integration into working tools for the building industry provided by the CRB [4.].

The research project shows the leverage effects of the most important decisions and their effects on the sustainability of high-rise building façades, whereby the insight can also be adapted to conventional building envelopes.

The developed matrix presents connections with respect to façade typology, the number of layers of transparent building elements and building utilisation. The relevant systems are assessed and viewed in relation to each other. Firstly, the project demonstrates the considerable influence of early planning decisions such as geometry or the construction using a created economic model. Secondly, a comparison between chosen reference sections shows that the structural details of the building elements and their cybernetic mode of action are decisive for the life-cycle of the building envelope. Buildings only become entirely sustainable with as long of a utilisation period as possible.

#### Keywords:

Sustainability of high-rise façades; life-cycle observations, sustainable envelope; decision making instrument

## 1 INTRODUCTION

### 1.1 Building envelope interface accumulation

Like human skin, the building envelope is a highly central and complex "organ". Unlike the classic façade, it three dimensionally surrounds the entire building volume including its underside, façade and roof and is therefore a building element that covers an extensive area. It serves

to mark the boundary between the interior and exterior, with all the significance, requirements and values that that entails. The building envelope plays a central role in connection with the energy demands of various labels. It is responsible for fulfilling daylight requirements, transmission losses, solar gains, etc. In view of today's and future requirements, the building envelope represents a growing investment factor

with respect to the facility's costs [5]. At the same time, in addition to power generation and building technology, it also represents a significant factor in the ecology of a building, in its capacity as a central grey energy factor and with respect to operative and maintenance costs, thereby representing a large proportion of the overall building system [6]. Today, life-cycle costs are often underestimated compared to production costs. In the planning and building process, the building envelope represents the "building site" with the highest complexity and interdisciplinarity. At that boundary, almost all fields of planning meet. In the building process, it also forms an accumulated interface between the different trades. As is known, the challenges of planning, logistics and the building site lie in those interfaces and their localisation and solution.

### 1.2 Focus on high-rise buildings in Switzerland

In Switzerland, tall buildings in general are the subject of heated debate in view of the demand for densification, both in the context of preserving the character of locations and also with respect to their architecture. The labels and the Swiss aims of quality in architecture and their implementation represent a unique characteristic that justifies currently limiting the research project on high-rise buildings [7] to Switzerland.

### 1.3 Underlying question

How can a sustainable building envelope be ordered and which influencing factors must be taken into account at an early planning stage? Practical experience shows that most clients and also planners are not completely aware of the complex interconnections and interactions.

The research project offers as comprehensive, valued and synchronized assessment order for possible questions and solutions with respect to decisions on a sustainable building envelope at an early planning stage.

## 2 METHODS

### 2.1 Terms and typologies of building envelopes

In the CTI-project "Building Envelope – A tool for decision making and assessment to produce sustainable façades for multi-storey buildings", 14 high-rise building façades were analysed and assessed with respect to their ecological, economic and social effects.

The term building envelope is suitable to describe an uninterrupted protective layer on all sides and includes the horizontal surfaces such as roof areas and undersides of that building element. Highly contrasting definitions are circulated with respect to the typologies of building envelopes. To grasp this great spectrum using uniform terms, the following matrix is developed (Fig.1):

- Primarily, the transparent building elements are relevant to energy requirements (solar gains, transmission losses, sun protection, sound insulation, etc.). The layers of the building shell on a horizontal plane play a primary role. One can distinguish between single or double-layered open and closed building envelopes (CCF).
- The building envelope can never be entirely uniform, since there are always interfaces between the respective façade and rooftop surfaces. Subsumed beneath edges, there are mountings and bonds. The relationship between the shell construction and the number of bonds generates the typologies of all-sided (punctuated façade), lintel and parapet (band façade), and roof and base (curtain wall).
- A further characteristic, the expression of the exterior opening structure, plays a significant role (not shown in the simplified matrix Fig.1). To differentiate the 2nd axis in Fig.1, a hole-shaped expression both with a conventional punctuated façade and as a curtain wall (e.g. Hochhaus Hagenholz) was created. But there

Layers of transparent building elements	double, closed CCF	Neubau Biologiezentrum UNI Basel		Roche Bau 5, Rotkreuz Bürohochhaus Allianz, Richti Areal Bf 7, Wallisellen
	double, open	Europaallee Bf A21/A22, Zürich Fachhochschulzentrum Bhf Nord SG, St. Gallen		Europaallee Bf A23, Zürich Hochhaus Hagenholzstrasse, Zürich (Abluftfassade)
	single	Hochhaus am Rietpark, Schlieren Wohnhochhaus Markthalle Basel Limmat Tower, Dietikon Mobimo Tower, Zürich (zwei Referenzausschnitte)	Hochhaus im Stadtwald 1, Rorschach (zwei Referenzausschnitte)	Prime Tower, Zürich Neuer Campus FHNW, Muttenz
		all-sided punctuated façade	lintel and parapet band façade	roof and base curtain wall
		edges in the façade surface		

Fig. 1: Typology of the building envelope.



are considerable differences in terms of building technology (weight, assembly, building progress) that have economic consequences for the two construction methods.

The typologies **layers** and **edges** are presented as a diagram with two axes as seen in Figure 1.

## 2.2 Building quantity structure

The analysed buildings vary greatly in assessing their quantities. The volumes (GV) range from the smallest building's 40,000 m<sup>3</sup> to the largest building's 420,000 m<sup>3</sup>. Overall, an extended quantity structure in accordance with SIA 416 analysed more than 380 storeys. The floor spaces (GF), with areas of 13,000 m<sup>2</sup> to 81,000 m<sup>2</sup>, make up a factor of 6.2. If one considers the relationship between the exterior envelope of the building to the floor space, the result is a proportion of 18% to 60% > factor 3.3 (cf. Fig. 2):

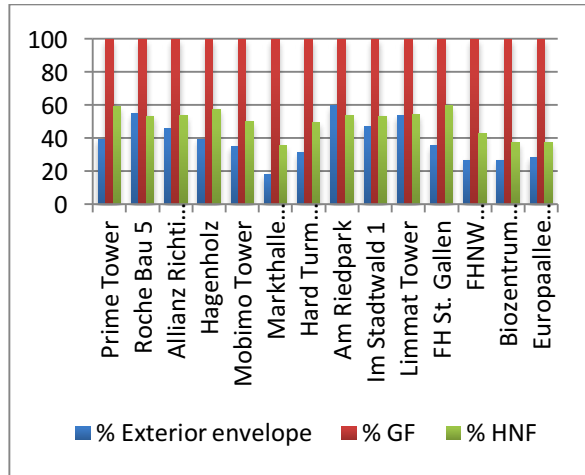

Fig. 2: Exterior envelope % (eBKP-H; E) to floor space % (=GF) and main usable area % (=HNF) to SIA 416.

### Economic model in accordance with CRB standard eBKP-H/2012

The CRB standard "eBKP-H/2012 Baukostenplan Hochbau" forms the basis of analysis. That classification describes the costs for the production of a building. The volumes and uniform prices have been produced for all façades according to the bottom-up method on the level of building elements. In the supplementary facility and construction costs, all volumes of the building were classified using model calculation (eBKP-H main groups A/B/I/V/Z) and individual calculation of the building envelope (main groups C/D/E/F/G). The comparability of the buildings is therefore ideal. In Fig. 3, the costs are derived as Fr./m<sup>2</sup> of the façade system E2.4 (eBKP-H) or the building envelope (façades above ground including roof). If the costs of the building envelope are combined with the geometry (GV/HNF), however, one finds the enormous influence of the quantity structure on the materials and their costs. The leverage effect of the geometry or its appropriateness is almost 50% of the building envelope and defines up to 23% of the facility costs.

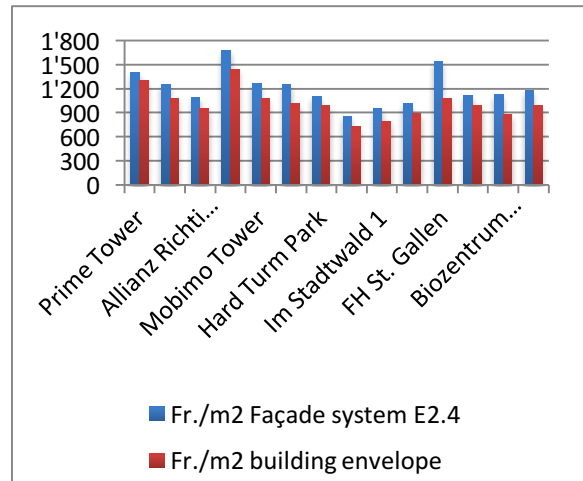

Fig. 3: Fr./m<sup>2</sup> Façade system and building envelope.

## 2.3 Reference section, module size and construction procedure

Figure 4 demonstrates the diversity of the reference sections. Some of the façade sections differ considerably in terms of their module size of 4.52 m<sup>2</sup> to 31.51 m<sup>2</sup>. All sections remain room-high however and vary between 2.86 m and 4.52 m in height. In terms of their breadth, the modules vary from 1.35 m to 7.05 m.

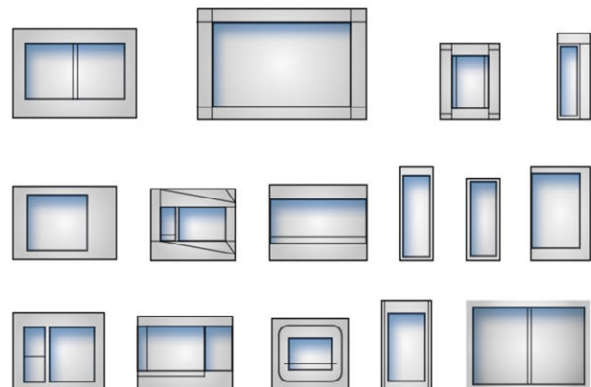

Fig. 4: Collected reference sections as a "façade zoo" without hierarchy.

## 2.4 Life-cycle assessment of a section in detail

The lifespan of the relevant building elements was determined using planning documents on a scale of 1:2 to 1:5. Rather than the material-related lifespan, it was the constructive study in detail that was decisive in the assessment of maintenance, renovation and dismantling. These key figures of life-cycle assessment over a period of 90 years formed the basis a holistic assessment of the sustainability of the high-rise building façades.

## 2.5 Qualitative factors

During the project, the IFZ studied the extent to which qualitative factors have an effect on the commercial success of an object. The project used two instruments for this purpose:

- A typology grid with respect to the building envelope, as a communication tool among experts, working with pairs of terms.
- The “QualiTool” developed by the IFZ to identify and quantify the quality in the sense of effectiveness in achieving the intended targets, in an analogous way to the SNBS procedure.

## 2.6 Life-cycle costing (LCC)

In an increasingly ecologically-orientated real estate economy, the process of life-cycle costs is accepted due to its holistic perspectives. Its inclusion in operative and disposal costs allows the principle of sustainability to be applied, since sustainability considerations often lead to lower operative and maintenance costs. Relevant concepts especially include studies by IFMA [9], CRB [10] and the SIA [11].

## 2.7 Levels of comfort

The assessment of levels of thermal and visual comfort was defined in five different categories (see Fig. 5: daylight, sun protection control, summer heat protection, cold air drop, openable windows) and implemented according to clearly defined criteria by the Centre for Integrated Building Technology ZIG. The categories cannot be compared to each other directly. Thus, the final result is presented in a qualitative assessment in point scores.

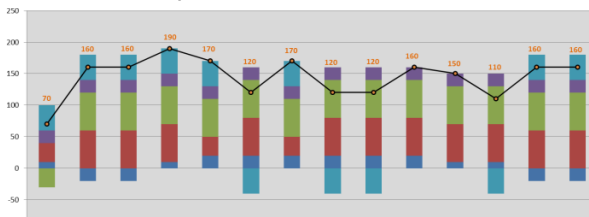

Fig. 5: Façade comfort level assessment. The leverage effects can be positive or negative depending on the assessment criteria. The façade design is strongly dependent on the relevant typology and use.

## 2.8 Life-cycle balance

The life-cycle balance of a high-rise building façade was defined by the quantity structure of the building envelope multiplied by the environmental factor of the individual building elements (UBP, grey energy, CO<sub>2</sub> emissions) [12], [13], [14]. As a rule, two comparative values were used in assessing the façades: The life-cycle balance of the added building materials added at the time of the high-rise building's construction without taking their intended use period into account, i.e. the life-cycle balance in Year 0 (without amortisation), and the life-cycle balance per year (with amortisation).

## 2.9 Energy requirements

Using thermal simulations (IDA ICE 4.2) the ZIG determined the energy requirements for heating, cooling and lighting of four reference buildings and compared them with the energy reports of all

buildings in accordance with SIA 380/1. The actual energy requirements of the building strongly depend on its users. There is a considerable savings potential through appropriate operative optimisation.

## 2.10 Qualitative guidelines for planning high-rise building façades

The Competence Centre for Façade and Metal Construction CCFM developed a qualitative assessment method to determine the following sustainability criteria: raw material origin, dismantling ability, effects on the micro-location, quality of the building structure, and façade weight. All reference sections were comprehensively assessed using a system catalogue of 22 building groups with 134 sub-categories.

## 3 RESULTS

### 3.1 Decisive leverage effects on producing a sustainable building envelope

The results of the CTI-Project “Building Envelope” show that the location and specific situation have the greatest effect on the building (cf. Fig. 6). The local conditions are decisive for the utilisation potential. The building is defined by its context and the legal stipulations. The greatest lever is defined as the **location**.

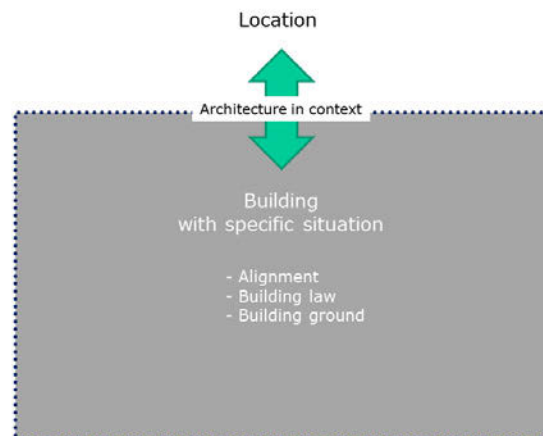

Fig. 6: Architecture as the interface between the location and the building.

The architecture acts as an interface between the location and the **building** with its specific situation in a historical, cultural, climatic and material-related context. On that level, the standard (quality) is determined with a direct influence on the costs. To assess the sustainability of the buildings, it was necessary to study the entire building. The volume of the building is formulated by the function and its use, while its expression is closely related to the façade typology. The leverage effects of the building envelope are therefore much more far-reaching in the building than the assessment of a 30-40 cm enveloping layer.

Based on these fundamental findings, **building utilisation** is considered to be decisive (Fig. 7). On the same level, the **identity** and **atmosphere** are considered to be significant. This may either be identification through a distant effect or through the component of the acceptance of buildings or building elements at close proximity. In each case, in addition to the purely functional utilisation period, **acceptance** and **comfort levels** play a decisive role for the lifespan of the building.

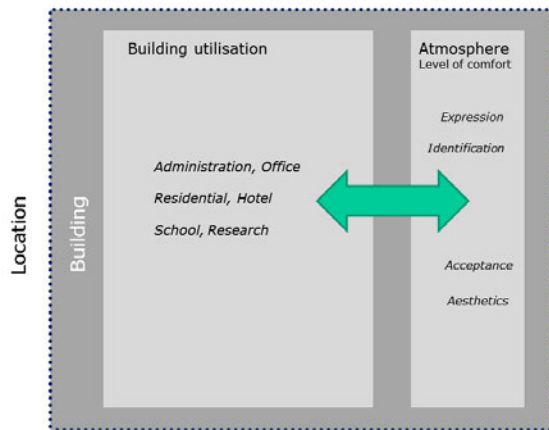

Fig. 7: Building use as a significant leverage effect in connection with the identity and expression of the façade.

The umbrella term of **geometry** comprises the following key leverage effects:

#### Volumetrics

- The compact nature of the building is decisive for the volumetrics; the volume is the greatest lever for production costs. On average, the building envelope makes up 20-25% of the overall construction costs (according to eBKP-H, main group C-G), while the exterior wall layer (E) is clearly the relevant main group of the building envelope, explicitly the façade system E2.4.
- On average, the construction C is responsible for 10-20% of the production costs.

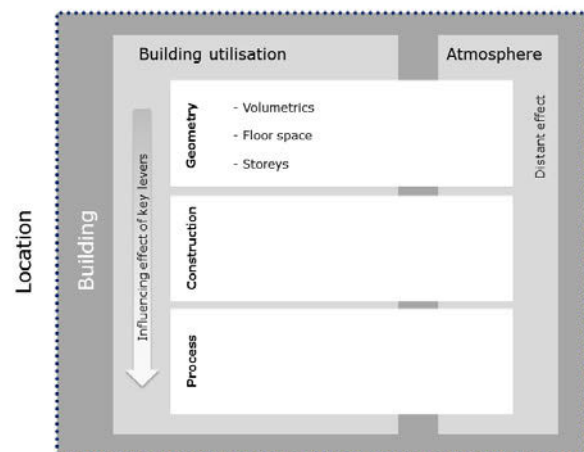

Fig. 8: Volumetrics, floor spaces and storeys as leverage effects of geometrics.

#### Floor spaces

- Depending on the spatial efficiency, the proportion of main usable area (HNF) to the floor space (GF) is 35-65%. The efficiency of the floor space is very important; offices and administrative buildings should aim for 60%.

#### Storeys

- The relationship between storey heights (OK/OK) and clear room height depends on other levers such as the envelope area. The multi-surface proportion of the façade should not be underestimated, which is necessary above suspended ceilings and doubled floors.

Another umbrella term is introduced with **construction**:

#### Elementation, layering, joining

- The façade typology is subject to various types of interaction, with clear relevance of the transparent (glazing) elements. The possible classification into single-layered and double-layered building elements and punctuated façades and curtain walls is reflected in all final reports by the departments.
- With respect to the principle of the primary structure, flexibility during the entire lifespan is significant for the sustainability of the building and building envelope.
- With respect to the principle of the primary structure, flexibility during the entire lifespan is significant for the sustainability of the building and building envelope.

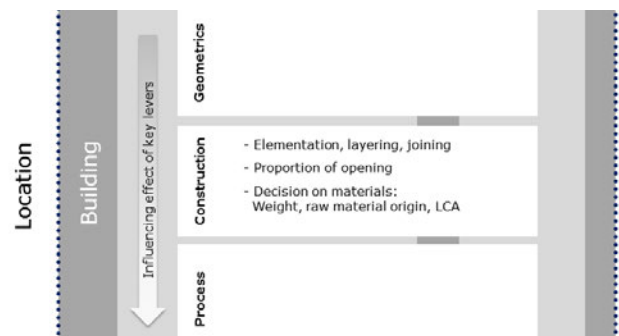

Fig. 9: Elementation/layering/joining, proportion of opening and decision on materials as leverage effects of construction.

#### Proportion of opening

- The proportion of opening is highly relevant to the level of comfort; it includes the factors openable windows, cold air drop, summer heat protection, daylight and life-cycle balance.
- In this context, the question of the complexity of the building envelope and the level of technology in connection with the building technology arises. Viewed over the entire life-cycle, a simple building system is favourable.

#### Decision on materials

- The decision on materials affects the weight of the façade and the life-cycle balance and is

closely linked to the identification of the building.

- The choice of materials allows raw materials to be used that come from sustainable, regional production, whereby specifically in façade construction, the option of a local, regional and international origin for raw materials is often difficult to apply. Most façade building elements such as glass, aluminium profiles, natural stone etc. are produced in neighbouring countries rather than in Switzerland.
- The frame element is extremely important for the grey energy and environmental impact points (UBP 2006, Vers. KBOB 2014). Curtain walls have significantly higher values than punctuated façades. But in this respect detail is also relevant, e.g. the façade of the Biozentrum Basel (double-layered closed cavity façade) has a very positive result due to the element's low frame proportion and large-scale glazing proportion.

The umbrella term **process** for further leverage effects:

#### *Planning and building site logistics*

- Scheduled planning should be defined in a project-specific way and is highly significant for the entire process. The level of prefabrication varies greatly as a result. The construction method of the façade and façade system is relevant to the building process.

#### *Assembly, dismantling, recycling*

- Complicated constructions such as structural glazing bonds or heavy cladding and their mountings have a negative effect on the sustainability of the façade with respect to the ability to dismantle them.
- Metal building façades are generally easier to dismantle, while curtain walls produce comparatively better results.
- The specific details and their components are relevant to simple assembly, dismantling and recycling.

#### *Processing and finishing quality*

- The quality of the processing and finishing is decisive for the functional utilisation period of the façade and the building element. A decisive component for the lifespan is the acceptance of buildings and building elements over a long utilisation cycle and its identification in a close-up effect.
- According to the DCF method, it is mainly the production costs that are relevant in observing the façade, whereby the constructive details and their joining, rather than primarily the material, are decisive for the utilisation period.

#### *Maintenance (cleaning, operation)*

- The costs for maintenance and renovation including dismantling play a subordinate role in the present value observation of 60 years for the

façade. This however results from the interest rate and the defined long period of observation for the maintenance in applying a dynamic calculation method of the DCF process (*IFZ report, 2.5.2014*).

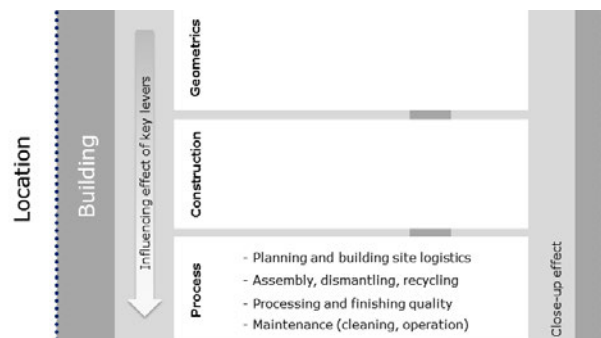

*Fig. 10: Planning, assembly, processing and maintenance as leverage effects of the process.*

## 4 DISCUSSION

### 4.1 A cross-comparison of high-rise building façades in Switzerland

To identify the key leverage effects to determine sustainability, it was necessary to move away from individual buildings and examine the test series buildings in a cross comparison (cf. Fig. 4 Reference sections). The selected 14 buildings in the CTI-project "Building Envelope" all achieved a very high standard, which is mainly ensured through architectural competitions and public debate. Another contributing factor in addition to the excellent quality is that tall and high-rise buildings are like the Formula 1 of the building industry. That means that the highest technical and structural requirements must be fulfilled in every respect. The comparison is therefore like a high-end test run of different building envelopes with a high public profile, not only in terms of their presence. The fact that many high-rise buildings are produced by private investors means that often diverging development steps are not revealed with respect to planning and building processes. The knowledge gathered by individual major investors based on many years' experience is generally not divulged to the public for reasons of competition. The role of the investor is decisive.

The CTI-project "Building Envelope" could however achieve a typological comparison due to the availability of extensive planning material and figures going down to in-depth detail. The produced diagram (Fig. 8 to 10) presents the decisive 10 substituent leverage effects to produce a sustainable building envelope in early planning stages as a guideline.

## 5 CONCLUSIONS

### 5.1 Findings

The findings of the research project can also be adapted to conventional building envelopes:

- The building envelope has a considerably more far-reaching effect than the exterior layer.
- Buildings only become entirely sustainable with as long of a utilisation period as possible.
- Viewed over the entire life-cycle, the constructive detail of the building element is decisive.
- The cybernetic mode of action of the overall system plays a key role for sustainability.

### 5.2 Outlook

The findings of the CTI-project "Building Envelope" should lead to the further development of the eBKP-H structural system through different hierarchies of the element structure as part of a follow-up project with the CRB (Swiss Research Center for Rationalization in Building and Civil Engineering) and participating economic partners. The aim is a statement on the overall costs of the building envelope (façade and roof) including the façade scaffolding, the proportional construction and the technology. A new factor is the full costing of the building envelope, taking life-cycle costs into account. Within the overall structure, the proportion of the building envelope will be determined. In this way, the relationships and figures of all themes and stages can be inferred. The comparison of different versions of building envelopes and their consequences thereby becomes coherent. Another new aspect is the observation of the utilisation funding per m<sup>2</sup> main usable area (HNF), subdivided into the following three sections: overall, building envelope proportion, and façade system proportion. The effects on the main usable area decisively take the utilisation period of the life-cycle into account. This further development of the construction cost plan eBKP-H would enable the integration of economics into the gained findings of the departments ZIG and CCFM and the implementation of calculation tools.

## 6 COAUTHORS AND RESEARCH TEAM

*Lucerne University of Applied Sciences and Arts – Engineering & Architecture (HSLU - T&A), Materials and Structure in Architecture FG MS A*  
 Prof. Dieter Geissbühler, Dr. Alexandra Saur (Admin. management), Marvin King (Content management), Stefan von Arb (Economics)  
 Report: "Geometry, construction, costs" (Geometrie, Konstruktion, Kosten).

*HSLU - T&A, Center for Integrated Building Technology ZIG*

Prof. Urs-Peter Menti, Gianrico Settembrini, Diego Hangartner

Report: "Comfort levels and life-cycle balancing of high-rise façades" (Behaglichkeitsbeurteilung und Ökobilanzierung von Hochhausfassaden).

*HSLU - T&A, Competence Center Façade and Metal Engineering CCFM*

Prof. Dr. Andreas Luible, Thomas Wüest

Report: "Qualitative guidelines for planning high-rise façades" (Wegweiser für die Planung von Hochhausfassaden).

*HSLU - Economics Department, Institute of Financial Services Zug IFZ*

Prof. Dr. Markus Schmidiger, Andreas Binkert

Report: "Soft influencing factors on the building envelope and life-cycle costs according to the present value method" (Weiche Einflussfaktoren der Gebäudehülle und Lebenszykluskosten nach Barwertmethode).

## 7 ACKNOWLEDGMENTS

We would like to thank the Commission for Technology and Innovation CTI for funding the research project (project funding no. 13903.1 PFES-ES) and the economic partners Halter AG / Implen Development AG / Losinger Marrazzi AG / Mobimo Management AG / Piora Generalunternehmung AG / Turintra AG c/o UBS Fund Management AG / Bau- und Verkehrsdepartement Basel Stadt / Bau- und Umweltschutzdirektion Kanton Basel-Landschaft / Baudepartement des Kantons St. Gallen / Aepli Metallbau AG / Diener&Diener Architekten / SBB Immobilien / Allreal Generalunternehmung AG / Burckhardt+Partner AG for providing extensive underlying data. Special thanks to the Swiss Research Center for Rationalization in Building and Civil Engineering (CRB) as the main implementation partner and Dr. Albert Müller for his support. Particular thanks also to Christian Höniger, the initiator and former project manager of the CTI-project, for the committed and sustained exchange of ideas. Finally, our warmest thanks go to Reto Gloor from GKP-Fassadentechnik AG in Aadorf, who decisively supported the CTI-project through his collaboration.

## 8 REFERENCES

1. HSLU T&A: Lucerne University of Applied Sciences and Arts - Engineering & Architecture
2. Departements FG MS A, ZIG, CCFM, IFZ. Lead: Research Group Materials and Structure in Architecture FG MS A
3. EAK/OAK: Swiss Catalogues of Element and Object Types, dt. Elementarten-Katalog EAK, Objektarten-Katalog OAK
4. CRB: Swiss Research Center für Rationalization in Building and Civil Engineering

5. Gloor, R., gkp Fassadentechnik, Lecture on March 6, 2012 at the HLSU: According to an estimate, the building envelope has an approximately 15-20% proportion of the construction costs with respect to basic construction.
6. Gloor, R., gkp Fassadentechnik, Lecture on 6 at the HSLU: The maintenance costs of the building envelope including cleaning of an optimised façade over a period of 50 years is 2.5 times the construction costs.
7. In Switzerland, buildings higher than 25 metres are regarded as high-rise buildings.
8. Herzog T., Krippner R., Lang W., *Fassaden Atlas*, Birkhäuser Edition Detail, Basel 2004, unter A2.1, Flächen– Strukturelle Prinzipien S.27
9. IFMA International Facility Management Association (Hrsg.): *Lebenszykluskosten-Ermittlung von Immobilien*. Broschüre und Anwendungstool mit 35 Excel-Tabellen. ISBN 978-3-7281-3364-9
10. CRB (ed.):
  - Leitfaden LCC: Planung der Lebenszykluskosten, Schweizerische Umsetzung der ISO 15 686-5. Zürich, 2012.
- Handbuch LCC: Instandhaltung und Instandsetzung von Bauwerken. Zürich, 2012.
- Anwendungsbeispiel LCC: Instandhaltung und Instandsetzung von Bauwerken. Zürich, 2012.
11. SIA (ed.):
  - Ordnung SIA 112: Leistungsmodell. Zürich, 2001.
  - Empfehlung SIA 112/1: Nachhaltiges Bauen – Hochbau. Ergänzungen zum Leistungsmodell SIA 112. Zürich, 2004
  - Ordnung SIA 113: FM-gerechte Bauplanung und Realisierung, Zürich 2010.
12. KBOB Ökobilanzdaten im Baubereich 2009/1:2014, Empfehlung Nachhaltiges Bauen, Koordinationskonferenz der Bau- und Liegenschaftsorgane der öffentlichen Bauherren, 2014.
13. Merkblatt SIA MB 2032 inkl. Korrigenda C1 2013, Graue Energie von Gebäuden, SIA-Merkblatt, Schweizerischer Ingenieuren und Architektenverband, 2010.
14. Merkblatt SIA MB 2040, SIA-Effizienzpfad Energie, SIA-Merkblatt, Schweizerischer Ingenieuren und Architektenverband, 2011.



## Expanding Boundaries: Systems Thinking for the Built Environment

### INTEGRATED APPROACHES FOR LARGE SCALE ENERGY RETROFITTING OF EXISTING RESIDENTIAL BUILDING THROUGH INNOVATIVE EXTERNAL INSULATION PREFABRICATED PANELS

G. Iannaccone<sup>1\*</sup>, G. Salvalai<sup>1</sup>, M. M. Sesana<sup>1</sup>, R. Paolini<sup>1</sup>

<sup>1</sup> Politecnico di Milano, Department of Architecture, Built Environment and Construction Engineering (ABC), via Ponzio 31, 20133, Milan, Italy

\*Corresponding author; e-mail: giuliana.iannaccone@polimi.it

#### Abstract

This paper shows the result of a research project aiming at the development of a systemic approach for the energy-efficient and cost-effective façade retrofitting of buildings deploying the potential of external insulation prefabricated panels.

In particular, an innovative composite panel (an EPS panel coated on both sides with two layers of Textile Reinforced Concrete - TRC) has been developed taking into account different parameters (mechanical properties, hygrothermal properties and environmental impact) and the potential of application on existing residential buildings in Europe. As a matter of fact, issues as lightness, fast and easy assembly techniques were also a major concern of the Research & Development process: the application without fixed scaffolds has been considered so as to reduce impact on inhabitants' life. Besides, considering some limitations on interventions of existing European building stock, the concept of the innovative panel has been developed so as to allow for the preservation of the building envelope exterior features or at improving the architectural features with a reduced extra-load on the existing structure.

Cost-effectiveness of the solution has been demonstrated considering optimization through the whole design and construction process, also exploiting the application of advanced design tools and Building Information Modelling (BIM).

The installation process and the real performances of the panels are investigated on a test-façade at Politecnico di Milano Campus: the first outputs of the test campaign are shown in this report, as well.

#### Keywords:

Integrated approach; outer solution; energy retrofitting; precast multilayer panel

## 1 INTRODUCTION

In recent years, the interest of the scientific community toward energy performances of buildings is more and more increasing due to the urgent need of effective solutions to the reduction of energy demand. Latest European Union programs related to energy efficiency underline the need for retrofitting existing buildings, which are responsible for 40% of EU final energy consumption. In this context, interventions on buildings dated between 1925 and 1975, constructed in an era where there was little or no consciousness about energy related issues, therefore with high energy demand, offer the higher benefit/cost ratio. This building category counts about 10 million buildings in EU-27, the

majority of them located in Central and Southern Europe [1]. A large part of this building stock requires façade retrofitting in general and this can be an opportunity to add an extra to improve the insulation and overall energy efficiency.

This paper shows some outputs of the EU funded EASEE research project which aims at the development of a systemic approach for the energy-efficient and cost-effective façade retrofitting of buildings deploying the potential of external insulation prefabricated panels. In particular, section 2 provides an overview of the research project and the design process of the outer façade retrofitting. Section 3 shows the results of the analyses carried out on the panel solution with reference to mechanical properties,

hygrothermal behaviour and environmental impact, including also the production of lab scale samples for preliminary testing. Section 4 presents the EASEE building retrofitting process and its application on a test-façade at Politecnico di Milano. Finally, conclusions are summarized in Section 5.

## 2 THE EASEE PROJECT AND THE INTEGRATED APPROACH

The goal of the EASEE (Envelope Approach to improve Sustainability and Energy efficiency in Existing multi-storey, multi-owner residential buildings) research project is to deliver new modular and fault tolerant solutions for the envelope retrofitting of multi-storey and multi-owner buildings, ensuring an important reduction of building energy demand through off-site prefabricated components and simplified construction processes and installation procedures, while at the same time reproducing the original façade and reducing at minimum the discomforts for the occupants [2].

The focus on the vertical opaque envelope takes into account the comparatively limited surface of the roof in these buildings and the fact that single-glass windows have been very often already replaced by owners with insulating glass. Another assumption of the project is that the slow rate of renewal of existing buildings is also a consequence of the process these retrofit operations are conducted, with non-skilled workforce and labour-intensive procedures that make costs escalate. The discomfort caused to inhabitants by long construction times, installation of scaffolding and the related dust and noise are other reasons that limit the diffusion of retrofit operations in practice. The EASEE project promotes a new holistic approach (Fig. 1) to the energy-efficient envelope retrofitting of multi-storey and multi owner buildings through a combination of integrated tools for building assessment and monitoring, innovative technological solutions for envelope insulation and building information modelling intended to pursue cost effectiveness throughout the design and construction process. The ultimate goal is to develop an EASEE Toolkit integrating affordable solutions and guidelines.

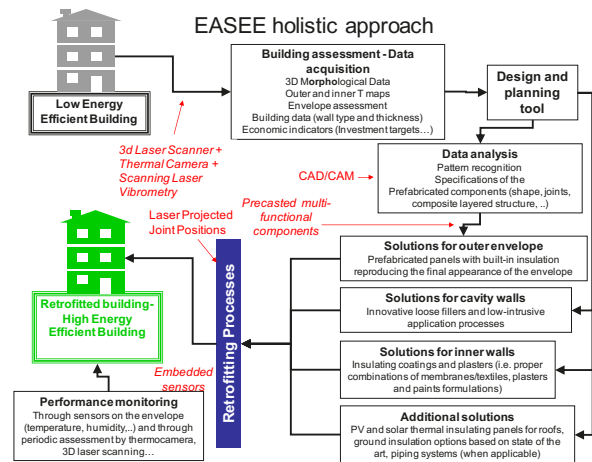

Fig. 1: EASEE approach to envelope retrofitting.

### 2.1 Outer envelope solution

The paper shows the developed key technological concepts addressing solutions for the refurbishment of the outer envelope and exploiting the potential of standardisation and prefabrication. Considering also previous experiences in other European countries – several of these are presented and analysed in the framework of EBC Annex 50 Prefabricated Systems for Low Energy Renovation of Residential Buildings [3] – the main goal of EASEE is to combine insulation and external finishing in one large prefabricated panel, deploying the production potential of the European precast concrete structures industry that primarily suffered from the recent economic crisis of the building sector.

The main concept was to combine insulation and finishing in integrated façade panels. The conceptual design of the prefabricated insulation panels was based on the main typological, morphological and technological features of the typical residential buildings dated between 1945-1975. These are mainly characterized by a reinforced concrete framed load-bearing structure and cavity brick walls. During the first stage of the project, different options for the panels were investigated, tested and evaluated considering performances in the service life in order to choose the best one to be brought forward for the demonstration activities. The selected solution is a prefabricated concrete sandwich panel obtained by coupling a layer of Expanded Polystyrene (EPS) with two layers of Textile Reinforced Concrete (TRC) 10 mm thick. TRC is a cementitious composite in which the matrix is reinforced with one or more layers of glass, carbon or aramid fabrics.



### 3 EVALUATION ANALYSES AND DATA OPTIMIZATION FOR PREFABRICATED SHAPEABLE PANELS

#### 3.1 General remarks on analyses

The investigation focused on the panel characterization by high residual strength after cracking as well as light weight. The insulation material considered had not only a hygrothermal role, but it was also chosen taking into account its mechanical characteristics. Moreover, high strength and ductility allow the designers to adopt large panels.

#### 3.2 Assessment of mechanical properties

The assessment of mechanical properties was conducted within two tests which permitted to establish also dimensional stability:

- Four point bending test;
- Bending test after freezing and thawing cycles.

The four point bending tests were carried out by using an electromechanical press INSTRON 5867 with a maximum load capacity of 30 kN. Four 50x150x5 mm aluminium plates were glued on each specimen at the supports and under the load knives to prevent localized failures. The tests were displacement-controlled by imposing a constant stroke rate of 3E-3 mm/s. The test highlighted that the panel is suitable to reach the desired dimensions (height of a storey about 3 m and variable width up to 3m) and the panel remains in the elastic regime when exposed to SLS wind [4].

The durability of the solution was checked on 550x150 mm panels thermally treated and then tested according to the four point bending scheme previously discussed. The thermal treatment consisted in 150 freezing and thawing cycles in a climatic chamber according to the Procedure A of the ASTM C 666 Recommendation. The specimens were exposed to several thermal cycles ranging between +4°C and -18°C with both cooling and heating rate of 11°C/h and a 30 minute rest phase both at +4°C and at -18°C. The external side of each specimen was completely surrounded by a water layer when subjected to the thermal cycles. The test demonstrated that the mechanical behaviour is not largely affected by the thermal treatment.

Summarizing the analyses conducted on the multilayer panel, it is clear that, after the test some cracks were visible, but the maximum crack opening was less than the one allowed at the Serviceability Limit State by the codes and it is such to maintain the global response of the cross section in the initial linear phase. Since the maximum thermal gradient at which the panels were exposed is not so large. It is worth noting that, thanks to the thermal inertia of the multilayer panel, the external surface temperature was significantly higher.

#### 3.3 Assessment of 1-D transient hygrothermal response

The hygrothermal risk assessment for the precast panels was performed with numerical simulations of dynamic heat and moisture transport by means of the software model WUFI 5.1 [5]. As a reference wall, a 34 cm thick brick wall has been considered (Fig. 2). The precast sandwich panel taken into account consists of an expanded polystyrene (specifically EPS 250) between two skins of TRC.

The water vapour diffusion resistance factor and the water absorption coefficient of the TRC concrete have been assumed based on laboratory tests. The thermal conductivity has been assumed considering the low porosity of the material (Tab. 1).

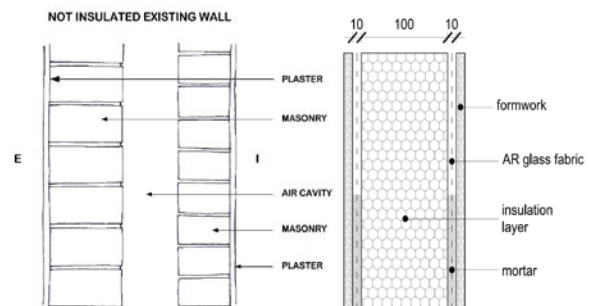

Fig. 2: Scheme of the existing masonry wall considered for the simulations (left) and of the retrofit panel (right).

Finally, as for the radiative properties of the exterior surface the thermal emittance was assumed equal to 0.90, while parametric simulations were performed with regard to the solar absorbance  $A_{sol}$ , thus assumed equal to 0, 0.25, 0.50, 0.75, and 1.00. Solar absorbances equal to 0 and 1 have no physical meaning, and they have been included to help identifying the limits of the contributions of solar radiation. However, the simulations with solar absorbance equal to zero approximate a condition relative to a shaded wall (e.g. wall having low solar absorbance, within an urban canyon, or with trees in front of it). The total porosity for the TRC has been assumed equal to 0.01, after mercury intrusion porosimetry tests.

Layer	t (m)	$\lambda_{10^{\circ}\text{C,dry}}$ ( $\text{W m}^{-1} \text{K}^{-1}$ )	$\rho$ ( $\text{kg m}^{-3}$ )	p (-)	$A_{w,24}$ ( $\text{kg m}^{-2} \text{s}^{-0.5}$ )	$\mu$ (-)
Plaster	0.02	0.80	1900	0.24	0.03	19
Clay brick	0.08	0.12	600	0.77	0.095	16
Air cavity	0.05	0.071	1.3	0.999	-	1
Clay brick	0.12	0.12	600	0.77	0.095	16
Plaster	0.02	0.80	1900	0.24	0.03	19
Air cavity	0.01	0.071	1.3	0.999	-	1

TRC	0.01	2.00	2311	0.01	0.0001	15000
EPS 250	0.10	0.04	30	0.95	-	50
TRC	0.01	2.00	2311	0.01	0.0001	15000

*Tab. 1: Layers and material properties. All the properties of the existing wall and of the EPS have been assumed from the WUFI database. The properties of the TRC have been measured in the lab or estimated.  $\rho$  is bulk density,  $p$  is total porosity, and  $\mu$  is the diffusion resistance factor.*

Hourly weather data from Meteonorm for Milano were used to describe the outdoor boundary conditions. The interior climate was defined according to Annex C of EN 15026 [6], thus with 20°C when the exterior temperature is lower than 10°C, 25°C when higher than 20°C, and linearly interpolated values in between. Two conditions of normal and high indoor moisture load, as defined by the standard. The start day for all the simulations was set as Oct 1<sup>st</sup>. Driving rain was computed according to ASHRAE Standard 160P [7] with rain exposure factor equal to 1, rain deposition factor equal to 0.5, and adhering fraction of rain equal to 0.70.

First, 25 years of hygrothermal exposure for the existing non-insulated masonry wall with intermediate solar reflectance finishing (i.e. 0.50) and with built-in moisture as in the WUFI's database for the selected materials were simulated. Second, the moisture contents averaged over the 25th year of simulation in the existing wall for the whole assembly including the precast panel were assumed. Then, 10 years of exposure of the whole assembly (i.e. existing wall + air cavity + precast panel) were simulated.

To assess the risk of increase in water content the 10 cm multilayer panel was divided into 10 layers of 1 cm and, from the results of the simulations, the highest moisture content across the EPS panel is concentrated in the first centimetre from the exterior. The focus is on water content, as it is a proxy of possible issues concerning the durability of a building component and of loss in thermal resistance. The relative importance of the different water sources is evident in Fig. 3 for a north facing wall with solar absorbance equal to 0.50 and with high indoor moisture load in different conditions:

- with a wet substrate (WETsub, moisture content in the substrate wall as at the end of a 25 year simulation) or dry substrate (DRYsub, moisture content in the substrate wall as 10 years after the retrofit)
- considering (Yrain) or excluding rain (Nrain)
- considering the capillary conduction of water (Ycap) or only water vapour diffusion (Ncap)

Condensation was estimated to weigh less than 4 kg m<sup>-3</sup> (and about 50% of the total) for the first 0.01 m of EPS. Considering all orientations,

internal conditions, and radiative properties of the exterior surface, within the first 0.01 m from the exterior of the EPS panel, the highest water content is of roughly 12 kg m<sup>-3</sup> for a north facing wall with zero solar absorbance (i.e. with high reflectance and no or very limited solar access) and high indoor moisture load. In more common cases, the moisture content in the most external 0.01 m of EPS is always lower than 10 kg m<sup>-3</sup>, displaying a decreasing trend (Fig. 4).

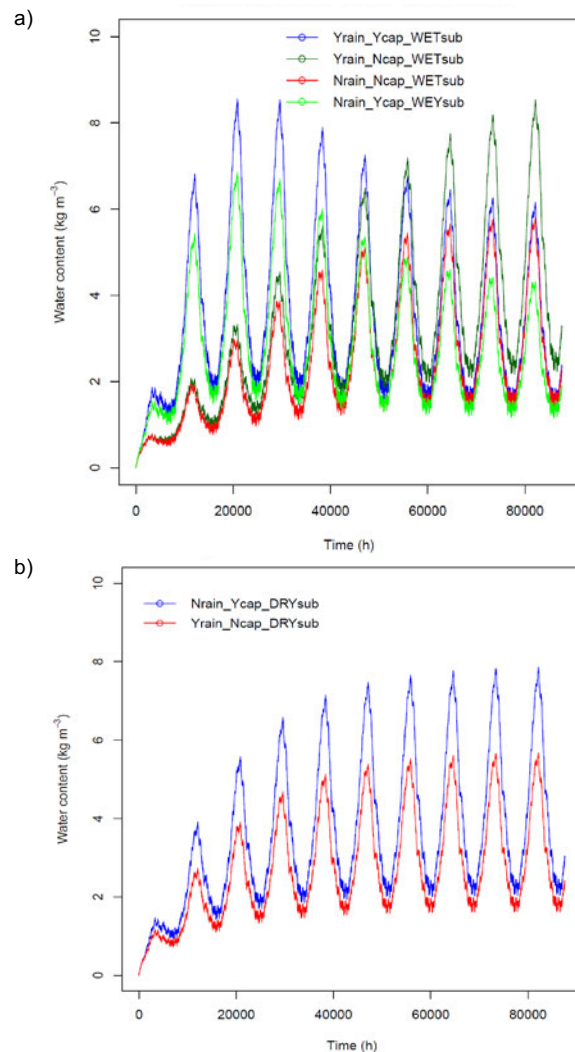

*Fig. 3: Moisture content over 10 years in the 0.01 m of EPS, for north exposure, with high moisture load with (a) wet or (b) dry substrate.*

Condensation does occur only in the most external section of the multilayer panel. The amount of condensed and absorbed water is not worrisome for the thermal performance, but it may affect the adhesion of the external skin of the panel (the TRC). After 10 years the moisture content within the whole assembly (pre-cast panel + wall substrate) gets to stable harmonic trends.

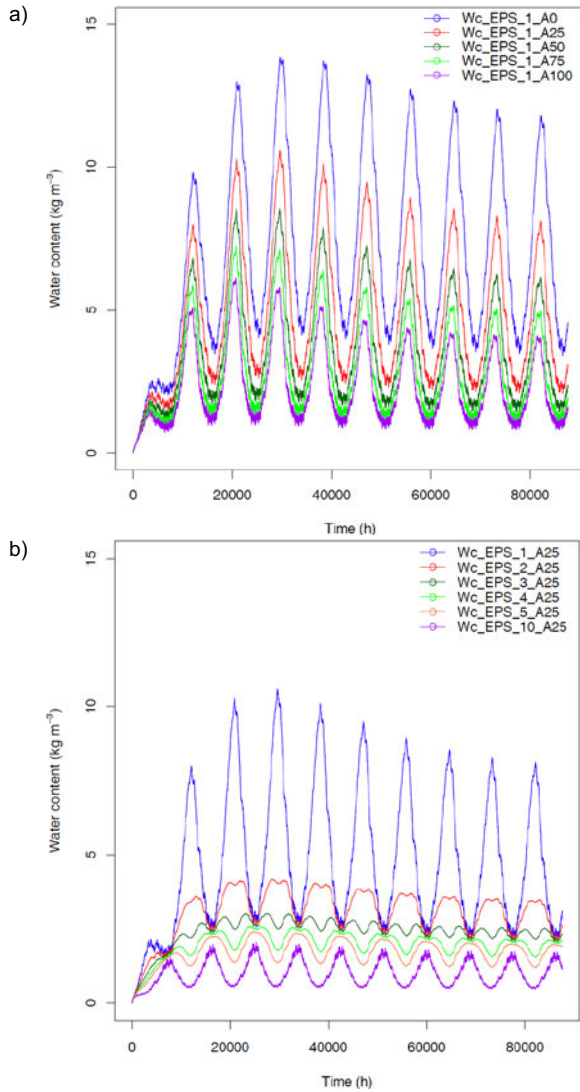

Fig. 4: Moisture content over 10 years in the 0.01 m (from the exterior) of EPS for north exposure with high moisture load (a) as a function of solar absorptance, and (b) for all EPS sections with solar absorptance of 0.25.

**3.4 Preliminary Life Cycle Assessment (LCA)**

LCA models the life cycle of a product as its product system, which performs one or more defined functions. In this case the multilayer panel provides the function of retrofitting a façade with a precast structure with a high thermal performance. The analysis has been developed following ISO 14040-14044 standards that codifies LCA method [8] and ISO 14064-14067 and PAS 2050 to evaluate carbon footprint. An LCA evaluation has been conducted on the panel within the retrofit operations and these evaluations have to be read as an indication of the potential environmental impacts that the assembly/production of the panels generates. Production wastes and hand labour are neglected. The functional unit chosen is 1 m<sup>2</sup> of panel. Singularities have not been evaluated because the analysis has been focused on the current section. The transportation is accounted

for separately and with the functional unit of 1 ton per kilometre. Primary data for materials, water and electrical energy consumptions were gathered directly from the assembly processes. SimaPro 7.3.3. software with the EcoInvent database is used. Material and energetic consumptions for the production of panels are quantified thanks to primary data. Electrical energy is referred to the Italian energy system, considering national performances and the various sources of origin.

For the impact analysis the indicators adopted were:

- Greenhouse gas protocol (GGP) – Carbon Footprint: global warming potential over 100 years for the evaluation of emissions and savings of CO<sub>2</sub>eq in atmosphere [kg CO<sub>2</sub>eq]
- CED: cumulative energy demand to calculate the renewable and non renewable energy consumptions of the process considering also feedstock energy [MJeq]

Greenhouse gas protocol provides CO<sub>2</sub>eq emissions divided into four contributions:

- Fossil: indicates the quantity of fossil fuels in the energy mix
- Biogenic: indicates the quantity of natural/biomass fuels in the energy mix
- From land transformation: indicates direct CO<sub>2</sub>eq emissions connected to some previous transformation applied to the material.
- Uptake: indicates the total CO<sub>2</sub>eq stored in the material during its life.

Table 2 summarizes the results obtained from the LCA analyses.

On the basis of this evaluation on a multilayer panel appears that the greatest amount of the impact of global warming potential is generated by concrete; from the energy side EPS still remain the material responsible of the major part of the impact.

Material energy	CO <sub>2</sub> fossil [kg CO <sub>2</sub> eq]	CO <sub>2</sub> biogenic [kg CO <sub>2</sub> eq]	CO <sub>2</sub> from land transformation [kg CO <sub>2</sub> eq]	CO <sub>2</sub> uptake [kg CO <sub>2</sub> eq]	EE non ren. [MJeq]	EE ren. [MJeq]
EPS	10,43	0,098	7,73 <sup>E-05</sup>	0,032	262,36	2,52
Concrete	19,58	0,321	9,64 <sup>E-05</sup>	0,068	180,62	6,96
Net	0,16	0,002	3,84 <sup>E-06</sup>	0,002	3,32	0,07
Electrical energy for mixer	0,12	0,001	3,78 <sup>E-07</sup>	-0,001	1,99	0,17
Electrical energy for compressor	2,26	0,024	6,62 <sup>E-06</sup>	-0,001	34,82	3,11

Tab. 2: Multilayer panel impact assessment.

The best results in terms of environmental impacts could be obtained using EPS instead of XPS and using as little concrete as possible. The longer the transportation route is the greater is the impact. The kind of lorry chosen for transportation affects the results: bigger lorry can deliver much more panels with little impact.

### 3.5 Building physical assessments of critical façade points

The criteria and method for the building physical assessment used and applied in the retrofitting process can be summarized as follows:

- Thermal performance of the envelope: reduction of the heat losses through the envelope by adding external insulation and minimizing thermal bridges
- Moisture performance of the envelope: ensuring drying capacity and avoiding condensation by choosing the proper materials and thickness layers
- Durability of the constructions: reduced risk of mould and decay by making the right choice of materials and ensuring the good moisture performance of the envelope

All the concepts were modelled with a hygrothermal simulation tool – MOLD SIMULATOR v.2, a software for the dynamic calculation of thermal bridges (ISO 13786 – validated ISO 10211) and mould and condensation risk assessment according to ISO 13788 [9]. With the help of the output result for temperature, relative humidity and moisture, a set of performance key values were determined for the critical parts of the constructions.

In particular, the detailed panel design has taken into special account joints between panels, which represent the very critical points of the façade. Dedicated analyses on the joint solutions between panels have been studied and tested on small prototypes to ensure that joints will not represent thermal bridges, maintaining at the same time the desired aesthetics of the façade.

One of the most critical point of the detailed panel definition was the design of the panel connection being influenced by many factors, playing an important role in the joint details. The design and execution of these joints is one of the utmost importance and must be accomplished in a cost-effective and efficient manner.

The isotherm diagrams in Figure 5 and 6 are relative to the details of the test façade presented in the Section 4. The colour diagrams show that critical heat flux occurs on the connection panels, however, since the isotherms are parallel towards the end, it indicates that heat transfer is essentially 1D, which is a good performance indicator and also that the chosen joint solution avoids thermal bridges between panels.

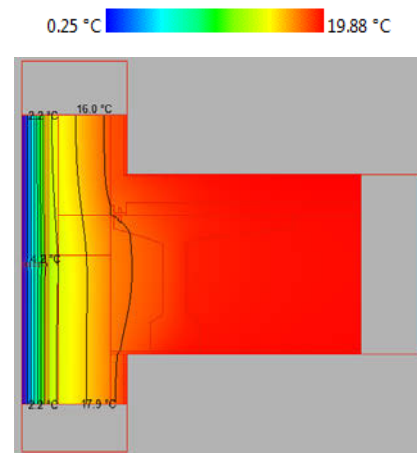

Fig. 5: Detail vertical section of the envelope regarding joint panels' connections.

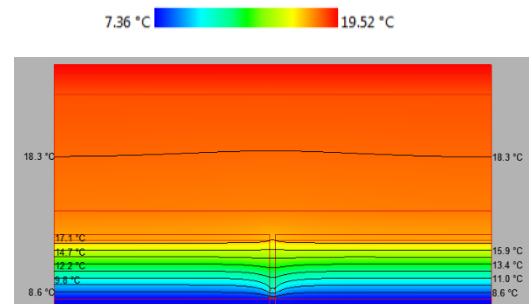

Fig. 6: Detail horizontal section between panels.

## 4 THE EASEE RETROFITTING PROCESS

The first step of the EASEE retrofitting process consists of the careful assessment of the existing envelope from both the structural and energetic point of view.

The geometry of the existing building is obtained through 3D laser scanning technique that allows acquiring a very detailed model and geometrical relief of the building. These are respectively elaborated through a Design Tool and a Retrofitting Planner that have been specifically developed during the EASEE project. Together with novel insulation systems, EASEE project delivered an integrated set of tools and services supporting the different stages and the different actors of the retrofitting process from the preliminary assessment of building geometry, to the panels' design and optimization for their manufacturing and installation.

The Building Information Modelling (BIM) process of gathering the right data at the right time during the EASEE retrofitting process was very challenging to create a robust connection between design, manufacturing and construction. The Design Tool (Figure 7), main output of the EASEE BIM approach, is an application devoted to construction purposes, allowing to place virtual panels on the buildings surface in a 3-D space referring to a grid which permits to control and modify all the panels parameters in order to

optimize their number and size. The final data can be then exported into the design documentation for both manufacturing and installation purposes.

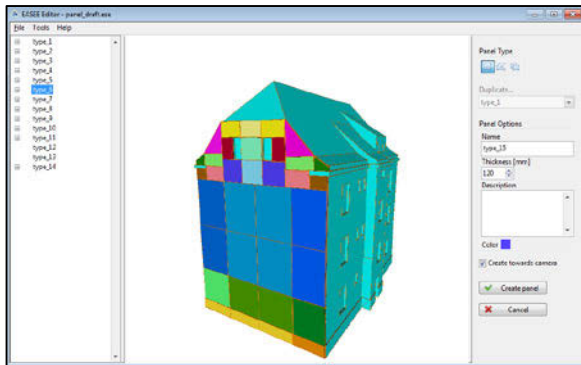

Fig. 7: Screenshot of the Design Tool.

#### 4.1 Test façade at Politecnico di Milano

The building chosen for the installation of the concrete sandwich panel prototypes is a university building built in the early '70s at Politecnico di Milano Campus in the city of Milan (Figure 8).



Fig. 8: Aerial view of the building.

The building hosts classrooms, research laboratories and departmental offices. The portion of the building that has been selected as test façade is the West front façade (first two floors). This façade is characterized by a rough concrete finishing since it was designed considering future expansion of the building towards the garden. From a structural point of view, the building has a concrete structural frame with prefabricated pillars and beams. The wall of the west façade between the pillars is made of cast-in-place concrete.

#### 4.2 Guidelines steps for the panels' installation

The first step regarded the survey of the existing building through the laser scanning technique (Figure 9).



Fig. 9: Point cloud image from laser scanning relief.

Through the correct georeferencing of the executive 2D design, a building 3D model has been developed in order to identify and locate discontinuities, projections and out of plumb of the façade and the correct positioning of the anchors (Figure 10).



Fig. 10: individuation of the bubble and entire anchoring system set-up on the test façade.

After these first set of operations, the panel installation started per rows on the façade (Figure 11).



Fig. 11: Installation and levelling of the panels on the test façade.

For the specific testing purpose only two rows of panels were installed (Figure 12). The joints between the panels were made using a low elastic modulus neutral-curing silicone sealant with outstanding ageing resistance. The silicon has been placed on polyurethane backfill material in order to reduce the danger of cracking.

The elasticity remains constant at temperatures ranging from  $-50^{\circ}\text{C}$  to  $+100^{\circ}\text{C}$ . The high resistance to UV rays and atmospheric agents foresees that after 20 years of service under normal conditions, the joints show no trace of superficial cracks.



*Fig. 12: Installation and levelling of the panels on the test façade.*

## 5 CONCLUSIONS

The EASEE research project developed an integrated approach for the energy retrofit of existing multi-storey and multi-owner residential buildings, which represent a large part of the existing European building stock. The technical development of the innovative insulation solutions for the existing walls was carried out in the first two years of the project and in the final two years these solutions were tested at real scale in demonstration activities, together with the whole integrated retrofitting process and the related software tools.

This paper summarizes the process from the design and preliminary analyses (mechanical, hygrothermal and environmental impact) to the final installation on a test façade of an innovative concrete sandwich panel (an EPS panel coated on both sides with two layers of Textile Reinforced Concrete - TRC) before its application on three occupied existing residential buildings selected in three different European countries as pilot cases.

The whole analysis on the prefabricated panel highlighted the high potential of the EASEE envelope retrofitting solutions.

The panels were developed to preserve the existing building envelope exterior features – or to improve the architectural features whenever possible – with a reduced extra-load on the existing structure and a reduced impact on the occupants because of the fast installation

procedure without scaffoldings. This solution offers high insulation value, air tightness, excellent comfort and visual quality and contributes to the reach of the energy standards for existing building under major renovations as underlined by the EPBD directive.

## 6 ACKNOWLEDGMENTS

The research leading to these results has received funding from the European Union Seventh Framework Programme FP / 2007-2013 under Grant Agreement n. EeB.NMP.2011-3-285540.

## 7 REFERENCES

1. JRC, Institute for Prospective Technological Studies, 2015, available at [http://publications.jrc.ec.europa.eu/repository/bits/tream/111111111/7070/1/reqno\\_jrc46667\\_jrc46667%5b1%5d%5b1%5d.pdf](http://publications.jrc.ec.europa.eu/repository/bits/tream/111111111/7070/1/reqno_jrc46667_jrc46667%5b1%5d%5b1%5d.pdf).
2. Masera, M; Iannaccone, G; Salvalai, G, Retrofitting the existing envelope of residential buildings: Innovative technologies, performance assessment and design methods. Conference Proceedings of the 9th ENERGY FORUM, Bressanone, 2014.
3. Peter Schwehr et al., Retrofit Strategies Design Guide. Advanced Retrofit Strategies & 10 Steps to a Prefab Module (2011), EMPA: Dübendorf, available at <http://www.iea-ebc.org/projects/completed-projects/ebc-annex-50/>
4. Colombo, I.G.; Colombo; M; Di Prisco, M, Bending behaviour of Textile Reinforced Concrete sandwich beams in Construction and Building Materials 95 (2015): p. 675-685
5. ANSI/ASHRAE Standard 160-2009. Criteria for Moisture-Control Design Analysis in Buildings.
6. EN 15026:2007. Hygrothermal performance of building components and building elements. Assessment of moisture transfer by numerical simulation.
7. ASHRAE Standard 160P - Criteria for moisture control design analysis in buildings
8. ISO 14044:2006 Environmental management -- Life cycle assessment -- Requirements and guidelines.
9. ISO 13786:2007 Thermal performance of building components -- Dynamic thermal characteristics -- Calculation methods



## Expanding Boundaries: Systems Thinking for the Built Environment

### LIMESTONE CALCINED CLAY CEMENT FOR A SUSTAINABLE DEVELOPMENT

A.Favier<sup>1</sup>, F. Avet<sup>1</sup>, M. Antoni<sup>2</sup>, K. Scrivener<sup>1</sup>

<sup>1</sup>Laboratory of construction materials, EPFL Lausanne Switzerland

<sup>2</sup>Innovation, Holcim Technology Ltd, Holderbank Switzerland

\*Corresponding author; e-mail: aurelie.favier@epfl.ch

#### Abstract

With cement production forecast to double by 2050, it is bound to increase pressure on the already fragile environment and the natural resource base. Critical analysis shows that the most viable option to improve the sustainability of cementitious materials are blends of Portland cement clinker with, so called, supplementary cementitious materials, SCMs.

Based on previous experience we have shown that cements with good strengths at early ages may be obtained by substituting clinker with a combination of calcined clay and limestone. Such blends offer a very promising solution for cements with a lower environmental footprint, particularly in terms of associated CO<sub>2</sub> emissions. In this paper, some initial results on chemistry, strength development and durability are presented.

The calcination of clays was known to give pozzolanic reactive material. The most reactive clay mineral is kaolinite, obtained after calcination between 600 and 800 °C. Therefore, the blending with calcined clays containing kaolinite provides an extra source of alumina to react with limestone. It was found that even low grade clay containing only around 40% kaolin gave good results when used in combination with limestone.

The low carbon cement developed is expected to reduce CO<sub>2</sub> emissions by 20-50%. Experimentation is ongoing to explore the potential of using low quality clay, which are available in large quantities in various places in many countries. These studies are expected to produce localized cement without the need to transport materials over long distances. It is envisaged that low carbon cement will be a much sought after commodity contributing to a sustainable development.

#### Keywords:

Limestone; calcined clay; cement; CO<sub>2</sub> emissions

### 1 INTRODUCTION

Concrete and Portland cement are essential building materials for society's infrastructure around the world. Although concrete based on Portland cement is a material with an intrinsically low environmental impact, the huge volume produced means it is responsible for large emissions of greenhouse gases (such as carbon dioxide) [1].

How can we reduce the environmental impact of the cement manufacture? The long term approach to lower the environmental impact of any material is to reduce its consumption. For several reasons, including population growth, the rate of concrete consumption probably cannot be reduced for some decades. In the short term, several solutions

have emerged, such as blended cements in which Supplementary Cementitious Materials (SCMs) substitute a part of the Portland cement. Table 1 presents the most common blending materials and their estimated annual production level.

SCMs	Estimated annual production level	Availability
Ground blast furnace slag	200 million tonnes (2006)	Future iron and steel production difficult to predict
Fly ash	500 million tonnes (2006)	Future capacity of coal-fired

		power difficult to predict	plant on
Natural pozzolans, silica fume	300 million tonnes (2003) but only 50% used	Depends on local situation	on
Artificial pozzolans (calcined clay)	Unknown	Depends on local situation	on
Limestone	Unknown	Readily available	

Table 1: Production level and availability of the most common supplementary cementitious materials adapted from CSI/ECRA technical reports [2].

In spite of the successful development of blended cements, the increase in the level of SCM substitution is slowing down because of a slow strength development at an early age and the limited supply of well-established SCMs such as fly ashes or slags. It is why we must move towards the use of other SCMs with extensive reserves worldwide.

Clays, especially low grade clays seem to be a good alternative SCM. In India, our experience [3] has shown important widespread availability of low grade clays in existing quarries. To be reactive, these clays must be calcined at around 700°C to 800°C [4]. However, this range of temperature is much lower than 1450°C needed for clinkerization, hence consuming less fuel. Furthermore, recently, it has been shown that by making a coupled substitution of calcined clay with limestone, 50% of clinker can be replaced by limestone and similar mechanical performance to Portland cement maintained, so the extra saving of clinker can offset the cost of calcination. Further important advantages of LC<sup>3</sup> technology are:

- Cheaper or similar production costs [5]
- Low investments costs [5]

The potential for ternary blends of limestone, calcined clay and clinker, which we call LC<sup>3</sup> (limestone calcined clay cement) has been demonstrated in the collaborative research between the Laboratory of Construction Materials (LMC) at EPFL, Switzerland, and CIDEM in Cuba [6].

## 2 RESEARCH AND DEVELOPMENT OF LC<sup>3</sup>

### 2.1 How LC<sup>3</sup> works?

Portland cement is essentially composed of clinker, gypsum and additions. Clinker is very reactive in the presence of water; it reacts according to the equation below (1):



(C: calcium oxide, S: silicon oxide, A: aluminium oxide, CH: calcium hydroxide, H=water)

This reaction (1) is the main, but not exclusive reaction that occurs during the hydration of cement. It produces the calcium hydroxide, which reacts with pozzolans such as calcined clays. Pozzolans are usually rich in silica in the presence of calcium hydroxide and water reacts according to the following equation (2):



On the other hand, the calcium carbonate (Cc = limestone) reacts differently. Several studies [7,8] have established that limestone additions up to 5% can react with cement. Indeed, limestone reacts with alumina to form hemi-carboaluminate and mono-carboaluminate phases as in equation (3):



This reaction (3) is enhanced by the presence of extra alumina coming from calcined clays. This synergetic effect was demonstrated in the past with fly ashes[9] and also verified by Antoni *et al* [6] in the case of calcined clays.

### 2.2 Performance of LC3

The interactions between the three different components previously described have been studied in depth at the lab scale.

It was shown [10] that the level of sulphate addition has an important effect on the early strengths of the LC<sup>3</sup>.

Further investigations were done to assess the potential of LC<sup>3</sup>, blends incorporating calcined clays from several countries were analysed. Fig. 1 shows the strengths obtained as a function of kaolinite content. It can be observed that kaolinite content is the main parameter determining compressive strength development. Moreover, all LC<sup>3</sup> mixes with kaolinite content up to 40% showed higher strength than normal Portland cement 42.5 grade (dotted lines in Fig. 2).

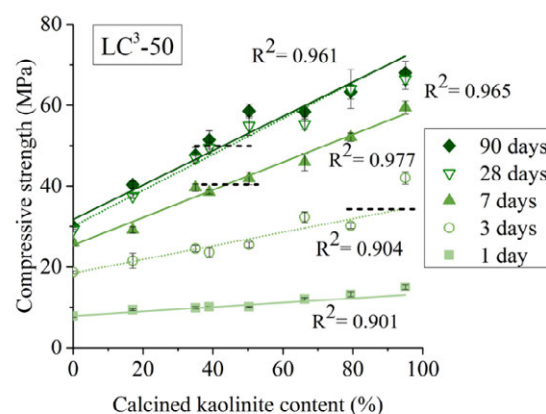

Fig. 1: Relation between kaolinite content which is calcined and the compressive strength from [11]. The dotted lines represent the strength of pure Portland cement at 3 days, 7 days and 28 days.



In practice, the very early strength (1-3 days) can be improved by a better optimization of process parameters such as grinding; using finer clinker can permit an important increase in early strength.

The same experiment was carried out for different grades of limestone and showed that the quality of limestone does not play an important role in the development of strength.

Durability remains a key question when considering a new cement formulation. A large range and detailed studies were carried out in EPFL, Cuba and India. These studies can help us better understand the involved physical and chemical mechanisms from the cement paste to the full scale structure. Although, it is early days and research is ongoing, preliminary results indicate that these materials have an equivalent or even better durability than Portland cement.

First, the phases present are the same as found in Portland cement or other blended cements, already widely used worldwide.

Second, as other blended systems [12–14], this material presents a refinement of porosity[10]. The pores are smaller even though the overall porosity may be similar or slightly higher (Fig. 2).

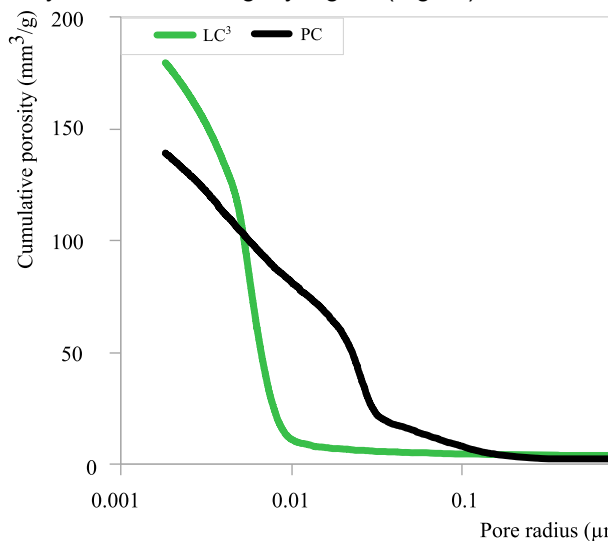

Fig. 2: Mercury Intrusion Porosity results for LC<sup>3</sup> (with 80% calcined kaolinite) blend and reference Portland cement PC.

Third, the work in progress on the resistance to sulphate penetration, chloride penetration or alkali silica reaction is encouraging. For example, preliminary results on resistance to chloride ions penetration shown in Fig. 3 are extremely good.

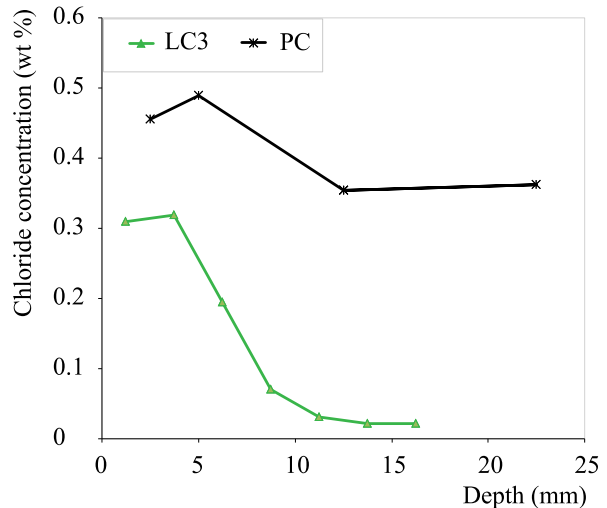

Fig. 3: Chloride profiles after 2 years ponding in 0.5M NaCl.

First results on carbonation tests tend to demonstrate that a longer curing of materials can be needed to assure the same resistance to carbonation than PC. However, performance was good for most applications.

### 3 FROM LAB SCALE TO INDUSTRIAL SCALE

To position itself as a potential large scale solution, the ternary blend material LC<sup>3</sup> must compete with materials already on the market.

After successful laboratory results, the technical feasibility was assessed using existing equipment in a cement plant.

In 2013, in Cuba, an industrial trial of 130 tons proved the feasibility of this cement with current technology. This cement was then distributed to companies of prefabricated construction materials. These companies have been able to make the same elements as with Portland cement (see Fig. 4).



a)



b)

Fig. 4: Prefabricated elements with LC<sup>3</sup> cement produced in Cuba, Siguaney a) hollow concretes blocks b) hydraulic tiles (courtesy of F. Martirena)

More recently in India, a collaborative work by Technology and Action for Rural Advancement (TARA) and Indian Institute of Technology Delhi[3] showed that the ternary blend cement LC<sup>3</sup> could be produced in large quantities. Several tons of four different LC<sup>3</sup> cements containing two limestones and two clays with different quality have thus been produced. These cements have been used for producing premanufactured elements such as concrete roofing tiles, hollow concrete blocks, door and window frames and paving blocks. These elements composed a demonstration house in Madhya Pradesh (India) presented in Fig. 5.



Fig. 5: Demonstration house made with ternary blend cement LC<sup>3</sup> in Madhya Pradesh, India.

#### 4 CONCLUSION

Housing shortage is a critical issue in most developing countries and concrete is the only well suited building material to face this challenge. However, due to this huge demand, the environmental impact of concrete is not negligible. For many years now, researchers and industrial studied and developed new cements to reduce its CO<sub>2</sub> footprint.

To be viable, the new solutions must be abundant, affordable and adapted to local requirements in developing countries.

The Limestone - Calcined clays - Cement LC<sup>3</sup> attempts to answer these three criteria. Today, this material can be produced using current technology in large scale in a usual cement plant. The components of this system especially low-grade clay and limestone are largely affordable and available everywhere. Moreover, the ternary blend promises to compete with other commercial solutions in terms of performance and durability.

Research on this technology is already been undertaken by several cement producers around the world.

Of course, more work on the scientific and engineering basis is required. A network of researchers from India, Cuba and Switzerland funded by the Swiss Agency for development and Collaboration makes this possible. We hope to expand this network to improve and complement the knowledge on this material to see it appear on the market as quickly as possible.

#### 5 ACKNOWLEDGMENTS

The authors gratefully acknowledge financial support from the Swiss Agency for Development and Cooperation (Project number 7F08527)

#### 6 REFERENCES

- Gartner, E. Industrially interesting approaches to "low-CO<sub>2</sub>" cements. *Cem. Concr. Res.* **2004**, 34, 1489–1498.
- CSI; ECRA *Development of State of the Art-Techniques in Cement Manufacturing: Trying to Look Ahead*; 2009.
- Bishnoi, S.; Maity, S.; Mallik, A.; Shiju, J.; Krishnan, S. Pilot scale manufacture of limestone calcined clay cement: The Indian experience. *Indian Concr. J.* **2014**.
- Fernandez, R.; Martirena, F.; Scrivener, K. L. The origin of the pozzolanic activity of calcined clay minerals: A comparison between kaolinite, illite and montmorillonite. *Cem. Concr. Res.* **2011**, 41, 113–122.
- Sánchez et al. Assessing the environmental and economic potentials of Limestone Calcined Clay Cement in Cuba. *J. Clean. Prod.* **2015**, Submitted.
- Antoni, M.; Rossen, J.; Martirena, F.; Scrivener, K. Cement substitution by a combination of metakaolin and limestone. *Cem. Concr. Res.* **2012**, 42, 1579–1589.
- Matschei, T.; Lothenbach, B.; Glasser, F. P. The role of calcium carbonate in cement hydration. *Cem. Concr. Res.* **2007**, 37, 551–558.
- Lothenbach, B.; Le Saout, G.; Gallucci, E.; Scrivener, K. Influence of limestone on the hydration of Portland cements. *Cem. Concr. Res.* **2008**, 38, 848–860.

9. De Weerd, K.; Sellevold, E. J.; Kjellsen, K.; Justnes, H. Fly ash–limestone ternary cements: effect of component fineness. *Adv. Cem. Res.* **2011**, *23*, 203–211.

10. Antoni, Mathieu Investigation of cement substitution by blends of calcined clays and limestone. **2013**.

11. Avet, F.; Snellings, R.; Alujas, A.; Scrivener, K. Development of a New Rapid, Relevant and Reliable (R3) Testing Method to Evaluate the Pozzolanic Reactivity of Calcined Clays. In *Calcined Clays for Sustainable Concrete*; Springer, 2015; pp. 539–544.

12. Zeng, Q.; Li, K.; Fen-chong, T.; Dangla, P. Pore structure characterization of cement pastes blended with high-volume fly-ash. *Cem. Concr. Res.* **2012**, *42*, 194–204.

13. Frohnsdorff, G. *Blended Cements: A Symposium*; ASTM International, 1986.

14. Day, R. L.; Marsh, B. K. Measurement of porosity in blended cement pastes. *Cem. Concr. Res.* **1988**, *18*, 63–73.





## Expanding Boundaries: Systems Thinking for the Built Environment

### DESIGN-ENGINEERING-BASED AND MATERIAL-BASED IMPROVEMENT OF PRECAST CONCRETE-FACADE-ELEMENTS

M. Pätzold<sup>1\*</sup>, F. Musso<sup>1</sup>, Th. Lechner<sup>2</sup>, O. Fischer<sup>2</sup>, D. Heinz<sup>3</sup>

<sup>1</sup> Chair of Building Construction and Material Science, TU München, D

<sup>2</sup> Chair of Concrete Structures, TU München, D

<sup>3</sup> Chair of Mineral Engineering, TU München, D

\*Corresponding author; e-mail: paetzold@ebb.ar.tum.de

#### Abstract

Concrete is globally one of the most common building materials in use today. Its key qualities are the load-bearing capacity, weather resistance and fire protection. However, a lot of energy is needed to produce it. Its effective replacement by new 'greener' materials with similar characteristics is currently under research but far in the future. Thus, new concrete construction methods have the potential to reduce the energy consumption considerably in the near future. The focus of our research is, not only to optimize concrete but also to develop a strategy to produce better precast components from this material.

The main focus is directed to the optimization of load-bearing exposed exterior walls. The objective is to develop and evaluate construction methods that reflect modern day concerns such as the need for good thermal insulation, the sustainable use of resources, the reduction of wall thicknesses as well as the ability to quickly erect buildings in inner city locations with high land value. The research project focuses in particular on insulation thickness and interesting facing concrete surfaces. Openings in the thinner walls have smaller window reveals, so natural lighting is improved as well. The results of the research project will be documented by technical drawings and photos of samples. The samples have been tested for durability, stability, and through exposure to weather.

#### Keywords:

Precast production; load bearing structure; dispersal; hydration retarder; design-engineering; material science; conservation of natural resources; recycling

### 1 INTRODUCTION

When this research was outlined in 2011, the German government had already developed strategies to limit the current effects on climate change and to encourage renewable energy. The so-called „Energiewende“ (energy revolution) [1] was formulated after the nuclear power plant incident in Fukushima and gave additional

momentum to this research approach.

The thermal performance of insulated double-wall concrete prefabricated elements can easily be improved. Fabrication in controlled factory conditions offers many possibilities for optimization [2]. The laboratory-like conditions allow thinner elements for higher buildings.



Fig. 1: UHPC-samples with different surfaces / EBB.

In addition, prefabrication allows the use of dispersals and can offer a variety of new concrete surface treatments.

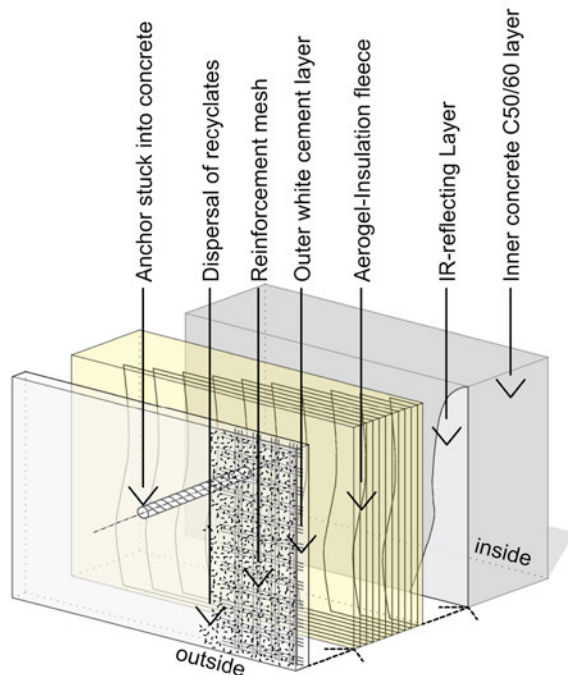

Fig. 2: Construction of the precast element / EBB.

## 2 MATERIALS (OR DATA) AND METHODS

In order to optimize the precast process, technical potentials should be combined to achieve efficient and convincing constructions. To assist the development of variations adjustable “levers” are defined that describe the solution spectrum: load-bearing effect, the connection between the outer and inner shells, the avoidance of solid sections through the use of filling materials, concrete composition, reinforcement, insulation and surface engineering. Samples of individual solutions are produced in mini trials to ensure feasibility. In particular, the concept of a double skinned composite construction is researched, whose elements permit integrated load-bearing. Promising options are selected and evaluated. Connecting details are developed and wall sections will be produced at full scale. Theoretical assumptions are practically tested on these preproduction mockups. The most successful approach is selected and worked up into a system through the further development of the sketched details, proposed materials and construction elements. The system limits for the wall are defined on the basis of the German EnEV 2016. The research goal shall be achieved by the work program:

- Interdisciplinarity:  
Specialists’ expertise will be incorporated into each procedural step in the development process.

- Alternative approaches:  
A range of proposals will be developed, manufactured and evaluated in accordance with the above mentioned variables.
- Systematic evaluation:  
The samples will be recorded and analysed to draw generally applicable conclusions.

## 3 RESULTS

The main focus will be directed to the load-bearing capacity and surface. As compared to their production on site, precast production conditions permit the creation of more complex and higher performance building elements. Using these optimal industrial conditions, this research project will strive to produce concrete with more organic, regenerable constituents and to create building elements that are more efficient by volume. At this point in time, the variables (“levers”) mentioned below have been researched with the following results.

### 3.1 Load-bearing behaviour

*Load-bearing effect: composite shell or load bearing inner shell*

The load-bearing effect of the outer and inner skin as a composite allows a larger structurally effective cross section [3]. The analysis of reference projects suggests that very large stresses can be expected in the joints between inner and outer shells when there are large temperature differences for instance in winter. As a consequence, composite inner and outer shell structure is not sensible.

*Connection of outer and inner shell: Material and form*

The connection of inner and outer shells as a storey-wise load transfer system in the outer shell should be achieved by means of round or square sectioned glass fibre anchors, which are poor heat conductors (Thermomass®/Combar®). With only a shallow bonding depth in the thin outer shell, anchor extraction tests show that a spiral form, fluted glass fiber with a chamfered end offers the best force transfer characteristics. It is structurally sufficient when the anchors are arranged perpendicular to the transfer load, an additional diagonal anchor is not necessary.

*Concrete composition*

The load-bearing effect of the outer shell with variable thicknesses has been tested for different concrete strengths for buildings of 5 to 6 storeys. Initial trials with UHPC showed that this material is, due to its very short workability period in a fully automated work process, not suitable for mixing in large concreting quantities. As a result, the testing reverted to the highest performance standard concrete, grade C50/60. Nevertheless,

structural calculations revealed a required thickness of 3cm for the outer shell and 9cm for the load bearing inner shell. Subsequent test series kept these dimensions as a basis.

#### Reinforcement: Material and Form

The first concrete sample elements used steel fibre reinforcement of (l/d) 09/0,15 (202,0 kg/m<sup>3</sup>), which had proved highly suitable in earlier trials with UHPC. A square mesh reinforcement (round bars of d=6mm) was proposed for use with the high performance grade C50/60 standard concrete. Thanks to the weather protected position of the element within the wall structure, concrete coverage of 20 to 25mm proved sufficient, as did a predetermined spacing of 8cm between the inner and outer reinforcement layers.

#### Compression test

Because of its superior workability, trials of standard concrete walls followed those of UHPC. Based on a 2.50m story height, the pin jointed top and bottom of the walls have a bending height of 2.50m. Regardless of the thickness of the walls, the eccentricity was initially limited to 1cm top and bottom. The walls are cast of a concrete that reaches an average compressive strength of at least 75 N/mm<sup>2</sup> after 28 days, with a modulus of elasticity of at least 36.500 N/mm<sup>2</sup> selected. Unless otherwise stated, only the wall thickness will be varied.

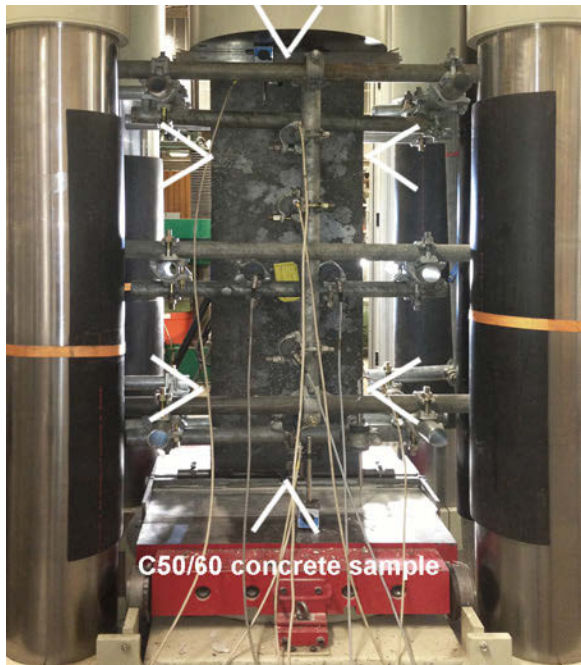

Fig. 3: Laboratory compression test / MB.

DIN EN 1992 (Eurocode 2) [4] will provide a reference for the determination of the bearing capacity of normally stressed unreinforced and lightly reinforced individual compression members and walls according to second order analysis.

$$N_{Rd} = b \cdot h_w \cdot f_{cd,pl} \cdot \phi$$

mit:  $\phi = 1,14 \cdot \left(1 - 2 \cdot \frac{e_{tot}}{h_w}\right) - 0,02 \cdot \frac{l_0}{h_w} \leq 1 - 2 \cdot \frac{e_{tot}}{h_w}$

$b$  Querschnittsbreite  
 $h_w$  Querschnittsdicke  
 $f_{cd,pl}$  Bemessungswert der Zylinderdruckfestigkeit  
 $e_{tot}$  Lastausmitte gesamt ( $e_0 + e_i$ )

Fig. 4: Second-order analysis / MB.

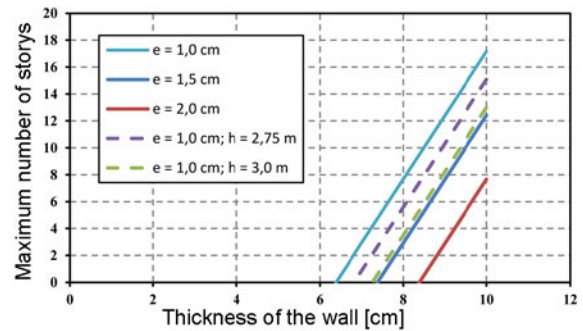

Fig. 5: Comparison of all test samples: Effect of eccentricity ( $e$ ) on possible story height with varying wall thickness / MB.

120kN/m loading per floor is applied to the bilaterally supported walls, this value is derived from the self-weight of a 30cm thick floor slab and an additional load of 1.5kN multiplied by a safety factor of 1.35 and a live load of 5.0kN multiplied by a safety factor of 1.50. Thus a biaxial load transfer and a maximum span of 12m – a draw-in width of 6.0m is achieved. Obviously, these constraints must be checked for each building. It is thus recommended to select an inner wall thickness of at least 8cm; a thickness of 9cm is optimal as this permits greater eccentricity.

### 3.2 Material performance characteristics

#### Insulation: Material and Form

Today, vacuum insulation provides the highest performance of thermal insulation. Risk of damage can be reduced through its exact embedding in the concrete matrix [5]. This high performance insulation can be replaced by a more robust phenol resin based insulation at reinforcement penetration points. This reduction in performance is possible as the phenolic foam insulation in these areas achieves acceptable levels of insulation. The minor temperature differences will be evened out through the thermal transmission of the outer shell.

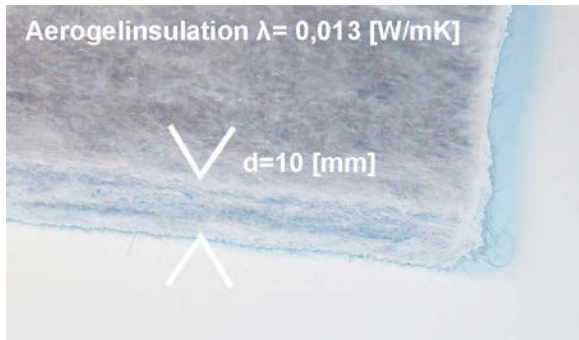

Fig. 6: Aerogel sample / EBB.

It has been revealed in the course of the project that aerogel fleece mats offer a similar coefficient of thermal conductivity along with substantially lower vulnerability. Due to the very low volume of production, the cost for these mats is still relatively high. However, a reduction in costs can be expected with increased demand and production.

#### Avoidance of solid sections through the use of filling materials

As part of research into the dimensioning of the inner loadbearing layer, the incorporation of additional insulation between the reinforcement anchors of the inner and outer shells was studied. This arrangement did not result in any concentration of the transmission of forces in the ribbed area provided for this purpose and thus also no increased insulation in the infill area.



Fig. 7: Thermal insulation as a moulding / EBB.

#### Heat measurement

At this stage, no trials have yet taken place in a heat chamber. The test is focused on the reduction of the wall thickness and the surface quality.

#### IR-reflecting layer

The use of IR reflecting foil can reduce thermal transmission. During Production on the outer side of the load-bearing layer an IR-reflecting foil should be applied. This additional layer improves the insulation of about 0,3m<sup>2</sup>K/W. This is equivalent up to 10mm of conventional insulation with the common thermal conductivity of 040. The vapour resistance of the metallic foil can cause humidity problems. This has to be verified while finishing the research project [6].

### 3.3 Surfaces

#### Surface engineering

Samples with different surface types will be produced:

- A formwork of absorbent fleece (Zemdrain®), wood concrete and mineral dispersals will be studied as a new surface for the outer shell.
- A hydration retardant will be applied to the formwork, which will leave the surface dispersals visible including a thin paste-like white cement concrete mix.

As a result of its simplicity, there is potential for automation and wide range of surface options; the latter alternative will be more closely studied. For each scattering type, two samples will be produced along with an additional piece for weathering tests.

#### Formwork

In the industrial precasting process, moveable steel formwork tables can be used. This will simplify the even scattering of the dispersal on the formwork. During the tests, this will be done manually. 30mm high Styrofoam strips will be cut and glued onto the clean steel formwork tables. To ensure a better visibility of the mineral dispersals, the underside of the horizontal concreting formwork will be painted with a curing retarder (CR Type N Reckli®, Türkis 0,25mm Typ Mikro) to prevent concrete slurry deposits.



Fig. 8: Formwork table / EBB.

After application and drying time, the retardant will be scattered with a variety of mixes. The retardant with the lowest penetration depth will be combined with dispersals of all sizes:

Sample	Material	Grain size
1-2	brick granulate	2-8mm
3-4	Alkali res. Glass chippings	2-4mm
5-6	deep draw quality A-PET	varies
7-8	ABS EX. Polylac 747	varies
9-10	mineralized wood	1-5mm
11-12	brass granulate	varies
13-14	titanium granulate	varies
15-16	humus	varies

Fig. 9: Schedule with different dispersals / EBB.



### Concrete

White cement creates a neutral appearance of the visible shell. The concrete mix design of the load-bearing shell is suitably tailored to the mass mixer requirements and produced. After careful judgment, aggregates (e.g. cellulose) are gradually added on site to achieve the correct consistency. The cellulose prevents the gravel from sinking during the curing period.



Fig. 10: Formwork table / EBB.

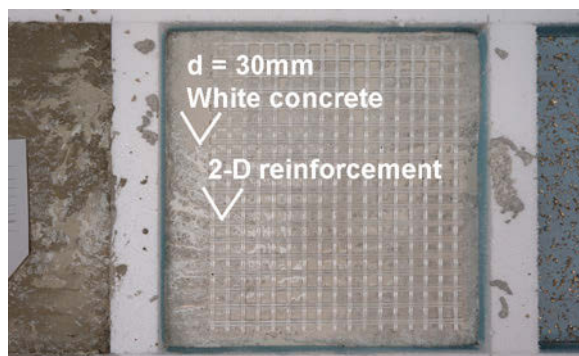

Fig. 11: Formwork table / EBB.



Fig. 12: Formwork table / EBB.

### Concrete technology investigation

The water-cement ratio of the load-bearing shell is determined after the production by a concrete technologist.

### Stripping of formwork

The formwork is stripped from the samples after a day's curing. The Styrofoam® mould is removed and the sample turned with the visible surface facing up.

### Curing of surface

The visible surface is evenly cleaned of retardant and concrete slurry with a high pressure water jet.

### Rule

The smaller the grain of the mineral dispersal, the smaller its optical effect and the stronger the leaching. The addition of the retardant allows the correct level of rinsing of the surface to reveal the dispersals to full advantage.

### Summary and strategy

The next step is to build on the good results so far and produce full-scale test samples of the inner wall construction with insulation.

### Merging of results in full-scale samples

The results of the sample production and surface enhancement encourage further investigations of full-scale samples of storey height panels. The production will be integrated into the assembly lines. The setting of the concrete mix requires the exact timing of reaction times of the curing retardant and the manufacturing process. Procedurally, the precast element is very easily and satisfactorily produced. The dispersals are evenly applied to the surface avoiding the points of contact of glass fibre reinforcement rods with the formwork table.

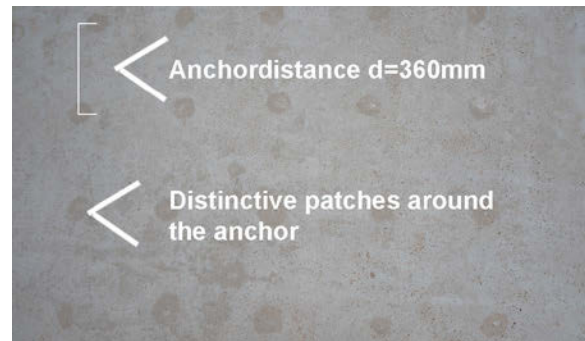

Fig. 13: View of the full-scale sample / EBB.

“Nests” and patches of darker coloured concrete appear radially around the anchor points. This may reflect a different compaction energy introduced around these points, which creates a distinctive structure in the surface of the concrete: The smooth whitish film that is found on the rest of the surface is missing above the anchor points. Here, different conditions are present during the surface drying process for the precipitation of calcium hydroxide or calcium carbonate [7]:  $\text{Ca(OH)}_2 + \text{CO}_2 \rightarrow \text{CaCO}_3 + \text{H}_2\text{O}$ . Results are currently under closer analysis. Despite these observations, the findings show that it is possible to produce 20-24cm thick concrete walls that can support a 5 to 6 story building, whilst having the performance characteristics of a Passivhaus. The small outer shell specimens show that it is possible, with just a little extra effort but without a levelling layer, to

produce high quality concrete surfaces that will be accepted by both clients and users. The full-scale samples require further optimization.

#### 4 DISCUSSION

From an ecological balance perspective concrete performs badly, but it has good characteristics in terms of load-bearing ability, fire protection and soundproofing. As a result of its poor ecological footprint, one possible approach would be to reject concrete as a building material as a matter of principle, and to research and develop alternative materials with similar properties. The disadvantage here is that reliable results may only become available years into the future. In order to make a positive contribution to the "energy revolution", this research project consciously follows the path of optimization of the existing: Because of the broad field of application and wide usage, an effective contribution can still be achieved.

#### 5 CONCLUSIONS

The cause of the colour and mix differences around the horizontal anchor penetration points must be determined; this should then point to a remedy. The integration of the wall system in a coherent prefabricated construction system for residential and office buildings of up to 6 storeys should take place in a further project. As part of which the fire performance must be investigated. The even distribution of the dispersals, e.g. crushed recycle, on the horizontal formwork tables can be improved in further research with machines. The results confirm the optimization potential for prefabricated concrete wall elements with the proposed materials and production methods. In dense urban spaces with high land costs, both the slenderness and innovative surface appearance of the newly developed approximately 20cm thick load-bearing outer walls play a significant role. The speed of construction will be optimized in terms of prefabrication and installation on site. The use of performance materials and recycles can contribute to sustainable building.

#### 6 ACKNOWLEDGMENTS

We want to thank our funder "Bayerische Forschungsförderung" and our research partner and sponsor "Rohrdorfer Betonwerke GmbH & Co KG".

#### 7 REFERENCES

- 1 Becker, Y., in: VDI ZRE Publikationen, Kurzanalyse Nr. 2 Ressourceneffizienz der Tragwerke, 2013, Berlin .
- 2 Jakubowski, G., in Ifeu-Institut, UFO-Plan-Vorhaben (FKZ 205 33 313), 2008, Heidelberg.
- 3 Gintars, D., Vakuumgedämmte Fertigteile in der Baupraxis, BINE Projekt Info (2007) H.09, S. 1-4 in Forschungsprojekt BINE (BMW, Projektträger Jülich GmbH, M. Kratz, Förderkennzeichen 0327321D), 2007, Jülich.
- 4 DIN EN 1992-1-1, Bemessung und Konstruktion von Stahlbeton- und Spannbetontragwerken - Teil 1-1, Allgemeine Bemessungsregeln und Regeln für den Hochbau. Beuth-Verlag, Berlin, Ausgabe: Januar 2011.
- 5 Bassi, A. in Voellinger, Th, Schlank und effizient / KTI/EPFL/CH, Werk, Bauen + Wohnen (2011) H. 1-2, S. 37.
- 6 Künzel, H., M., Sedlbauer, K., Klarstellung zur bauphysikalischen Wirkung Infrarot reflektierender Schichten, in: IBP-Mitteilung Nr. 479, Fraunhofer Institut Bauphysik, 2007, Stuttgart.
- 7 Strehlein, D., E., Fleckige Dunkel-färbung an Sichtbetonflächen, Charakterisierung - Entstehung - Vermeidung, Diss. TU München, 2012, München.

Captions: EBB stands for the professorship "Entwerfen, Baukonstruktion und Baustoffkunde", Chair of Building Construction and Material Science, MB stands for "Massivbau", chair of Concrete Structures.



## Expanding Boundaries: Systems Thinking for the Built Environment

### LIFE CYCLE ASSESSMENT OF A POST-TENSIONED TIMBER FRAME IN COMPARISON TO A REINFORCED CONCRETE FRAME FOR TALL BUILDINGS

L. Cattarinussi<sup>1</sup>, K. Hofstetter<sup>1</sup>, R. Ryffel<sup>1</sup>, K. Zumstein<sup>1</sup>, D. Ioannidou<sup>2</sup>, M. Klippel<sup>1\*</sup>

<sup>1</sup> Chair of Timber Structures, ETH Zurich

<sup>2</sup> Chair of Sustainable Construction, ETH Zürich

Stefano-Franscini Platz 5, 8093 Zürich, Switzerland

\*Corresponding author; e-mail: klippelm@ethz.ch

#### Abstract

This paper summarises a recently conducted project to investigate the sustainability of high-rise timber buildings. In particular, an innovative post-tensioned timber frame structure using glued laminated timber was compared to a functionally equivalent traditional reinforced concrete frame by means of a cradle-to-gate Life Cycle Assessment (LCA). Further, the two structures were compared with regard to costs and time for the construction. The assessment showed that the post-tensioned timber frame structure contributes about 44% less on greenhouse gas emissions compared to the traditional reinforced concrete structure. Additional performed analysis estimating the construction costs and construction time showed the great potential when using timber in comparison to reinforced concrete.

#### Keywords:

Life-cycle assessment; Post-tensioned timber; Reinforced concrete; Costs; Construction time; Greenhouse gas emissions

## 1 INTRODUCTION

Over the past decade, the design industry has been increasingly looking towards timber as a building material for the construction of tall buildings as timber has great material properties and at the same time can be considered an attractive material for green building construction. Investors and owners place a greater importance on sustainability in building construction and operation, as buildings are a major contributor to greenhouse gas emissions [1].

Since timber is considered as a renewable resource and forests supplying timber can offer a natural carbon sink, the use of timber in building construction can positively contribute to sustainable building practices.

In this context, an innovative post-beam construction made of glued laminated (glulam) timber was developed at ETH Zurich, namely the post-tensioned timber frame [2], see Fig. 1. A glulam column is being connected to glulam beams using a straight steel tendon. No additional steel elements are required. The high degree of

the systems' pre-fabrication leads to higher and controlled construction quality, to an easy construction on site, to a reduced construction time and to an enhanced safety on site. The frame is able to carry gravity loads and horizontal loads, therefore no additional load-bearing elements are required for the building, leading to a great amount of flexibility for the users.

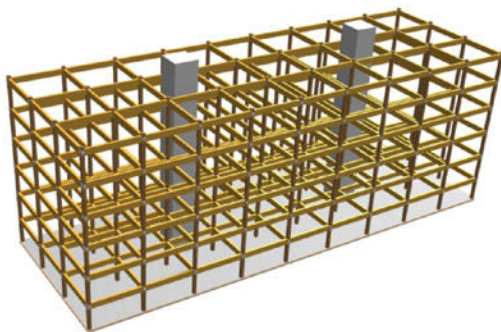

Fig. 1: Post-tensioned timber frame.

A structure of a newly built 3-storey office building at ETH Zürich (*ETH House of Natural Resources*) has recently been built with the post-tensioned timber structure made of glulam using hardwood

(*ash* and *beech*) and softwood (*spruce*), see Fig. 1. The hardwood reinforcement is needed to strengthen the supports, where stresses perpendicular to the grain occur.

The post-tensioned timber frame structure is a possible timber construction, which allows building tall timber buildings in a very efficient way. In this context, a feasibility study was performed within a master project thesis at ETH Zurich investigating the possibility to build tall timber buildings with this structure and further to study the potential and benefits of this structure when used for tall buildings.



*In case of the timber building:*  
Timber columns: *ash*, GL48h, 400 x 400 mm<sup>2</sup>  
Timber beams: *spruce*, GL24h, 200 x 600 mm<sup>2</sup>

*In case of the concrete building:*  
Concrete columns: C80/95,  $\varnothing = 450$  mm

*Note: Given are the maximum dimensions of the ground floor; column size is stepwise arranged, decreases with buildings' height.*

**Fig. 2:** Schematic sketch of the skeleton system made of post-tensioned timber.

In a first step, the preliminary structural design of two exemplary buildings was performed. Based on this design, a life cycle assessment concentrating on the structural elements as well as estimations on costs and construction time were conducted. This paper summarises the main results of this investigation.

## 2 HIGH-RISE BUILDINGS IN A SKELETON SYSTEM FROM CONCRETE AND TIMBER

A preliminary structural design for two high-rise buildings has been performed. One building uses the post-tensioned timber frame as structural elements. The second building is constructed as a traditional reinforced concrete building. In order to reasonably compare the two buildings with each other, they were planned with exactly the same function and size. The boundary of the buildings is as follows:

- 90 x 24 x 57 in [m] (length x width x height) including storeys for building technology
- 17 storeys above ground
- 2 storeys below ground for parking, storage and building technology
- Height per storey: 3.35 m
- Reference building area: ~ 41'000 m<sup>2</sup>

- Foundation on gravel (15 m thickness) above multiple layers of marl and molasse

Both buildings were planned as a skeleton system being a very flexible structure allowing a fast and easy change in use.

The buildings were designed as an office building located close to Basel (CH). The design of the building considers the new fire regulations in Switzerland [3]. Further, the design for earthquakes was performed for the seismic risk zone Z2, building class 2, subsoil class D and a behaviour coefficient  $q = 3$  according to SIA 261 and SIA 262 [4,5].

### 2.1 Structural system and materials

The design of the buildings was performed according to the Swiss design Standards SIA. Required dimensions and material properties are the outcome of the structural design of the two buildings. However, it should be noted that the design is of preliminary state meaning that the final dimensions and material properties might be improved for the final design.

The building using the post-tensioned timber frame as the structure is consequently planned with timber floor elements with additional mass and insulation to fulfil the serviceability limit state design requirements, e.g. vibration and sound insulation. The floors in the concrete building are consequently planned as traditional reinforced concrete floors.

Both buildings are horizontally braced with a reinforced concrete core with equal dimensions and functional units, although the timber building might allow for a reduction of the core dimensions due to the lower self-weight in comparison to the concrete building.

Dimensions and material properties of both buildings are the result from the structural design, see Fig. 2. Using timber for the structural frame elements leads to a strong reduction of building weight. In our particular case, the timber building can be built on a spread foundation and thus does not need any pile foundation. Whereas the concrete building is only possible to realise with a pile foundation due to its rather high self-weight.

### 2.2 Life-cycle assessment

#### *Definition of the system and data collection*

The environmental advantages of using timber as a structural element in construction have been discussed in various research endeavours [6,7,8]. In [6] and [7], it was proven that the substitution of a concrete with a timber building in a Swedish context can lead to reduction of the climate impact potential between 50% and 200%, considering also the option to capture CO<sub>2</sub> in the timber material. John and Habert examined the environmental impact of timber and concrete buildings in a Swiss context and affirmed that timber outperforms concrete in terms of environmental behaviour [9]. However, the

buildings examined in the latter study were medium-rise (3 to 4 stories high). In the current research, the goal was to study the environmental performance in the case of the high-rise building described above through a comparison of a timber building and a conventional reinforced concrete building.

The two buildings with the same structural system but different materials were analysed using a Life Cycle Assessment (LCA) in order to identify the main contributors to carbon emissions. LCA is a tool used to trace the environmental impacts of a product throughout its life cycle from raw material acquisition to production, use, maintenance and final disposal [10,11]. In this study, the boundaries of the system correspond to a cradle-to-gate analysis, encompassing all processes up to (and including) the construction of the building. The CO<sub>2</sub> emissions were calculated based on the method IPCC 2007 (GWP 100a) [12] with the use of OpenLCA 1.4.2 and the Ecoinvent v2.2 database [13].

In order to be able to compare the environmental impact of the two buildings, the structural floor system of the building with the same gross floor area and the same structural and thermal performance was used as the functional unit.

Furthermore, the following assumptions were made for the purposes of this study:

- The life cycle of the buildings was assumed 60 years. All main construction materials were assumed to have a service life of 60 years [9].
- The use of insulation of the same thickness in the roof and the basement as well as the provision of the same openings in both buildings ensure the same thermal performance, and thus a similar energy consumption during the use phase.
- The transportation distance from the manufacturing to the construction site was assumed to 30 km for concrete, since it is locally produced, and 150 km for steel, which is usually transported over longer distances. With respect to timber, two scenarios were tested: (1) in the first case, timber was transported by truck inside Switzerland for 150 km while in the second one, it was imported from abroad. In this case, a transportation distance of 2500 km (which is

about the distance from Swedish forests to Switzerland) was assumed, either by (2) train or by (3) truck. No transportation distance for the common materials was accounted for.

- The Life Cycle Inventory for the structural elements for both buildings is shown in Table 1. Under the category “other materials” belong all non-structural elements, such as floating screed, insulation material, gypsum plasterboard or bitumen sealing, among others. Steel includes the reinforcement required in both buildings as well as the pre-stressed tendons in the case of the timber one.

### Results and discussion

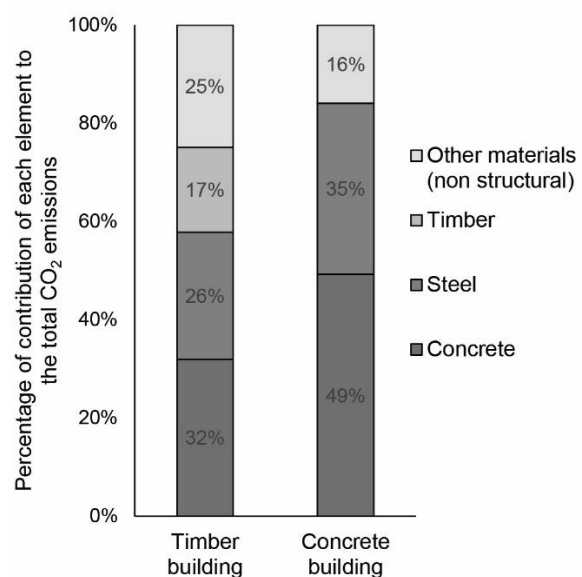

Fig. 3: Contribution of structural elements to CO<sub>2</sub> emissions of the timber and concrete building.

A comparison of the LCA of the two buildings is presented in Fig. 3. No transportation is included in the values of the figure. The results show that the manufacturing phase of timber products demands a very low amount of energy relative to reinforced concrete. In both buildings, reinforced concrete plays a determining role in the environmental performance of the building; concrete and steel together contribute to 84% of the total CO<sub>2</sub> emissions of the concrete building and 58% of the timber one. In the timber building, the largest part of the emissions is attributed to the construction of the concrete core and the

Material/Element	Unit	Timber building	Concrete building
Concrete	[m <sup>3</sup> ]	6'241	17'464
Steel	[t]	833	1'991
Timber	[m <sup>3</sup> ]	4'990	0
Other materials (non structural)	[t]	5'304	5'476

Table 1. Life Cycle Inventory for the Timber and Concrete Building.

basement. Among the other non-structural materials, floating screed has the highest contribution to the total greenhouse gas emissions (16% for the timber building versus 9% for the concrete one). Table 2 summarizes the CO<sub>2</sub> emissions of the two buildings.

	Timber building	Concrete building
Total t CO <sub>2</sub> eq.	4'774	8'478
t CO <sub>2</sub> eq./m <sup>2</sup>	0.116	0.207
	56%	100%

Table 2. CO<sub>2</sub> emissions for the two buildings.

With respect to transportation, it is observed that, with the exception of timber sourced from distant forests and imported by truck, transportation of the structural elements does not contribute significantly to the greenhouse gas emissions of the construction (Fig. 4). Regarding the transportation of timber over long distances, the railway network should be preferred. Further, it is recommended to use local timber (if the strength class is locally available) and avoid long distance transportation especially by truck.

It should be mentioned here that many building certification schemes prescribe specific requirements for the use of timber. For example, Minergie-Eco® in Switzerland excludes the use of wood from non-European forests without a FSC (Forest Stewardship Council) or PEFC (Program for the Endorsement of Forest Certification schemes) label.

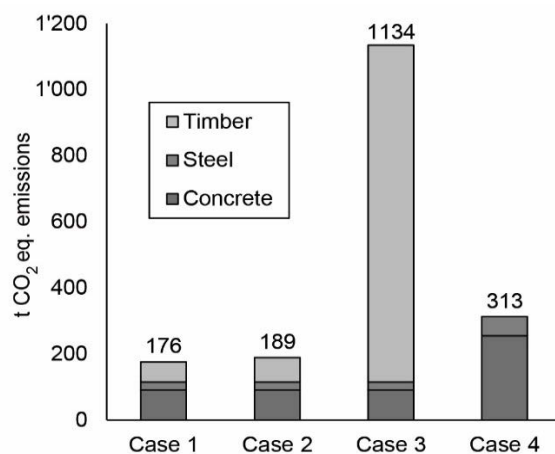

Fig. 4: Impact of transportation of structural elements for the different scenarios (Case 1: Timber building – 150 km by truck, Case 2: Timber building – 2500 km by train, Case 3: Timber building – 2500 km by truck, Case 4: Concrete building).

These labels ensure that wood is sourced from sustainable forestry. In addition, the use of local timber is in alignment with the requirements of Minergie-Eco®, which promotes the use of materials with reduced environmental impact in order to achieve a long life cycle, flexibility in the

use and possibility of deconstruction (eco-bau, 2011) [14].

As mentioned before, the LCA performed in this study does not account for the end-of-life of the two buildings. End-of-life scenarios entail considerable uncertainties since they attempt to predict future events, where the fate of the demolished materials is highly uncertain [15]. The end of life of the timber structure can involve either disposal of timber, use as fuel for electricity generation or disassembly and reuse of the timber elements. It should be noted that timber systems for prefabrication and disassembly (two main advantages of the analysed post-tensioned timber frame) allow for reuse of the material and a more resource-efficient product life cycle than typical demolition and down cycling. On the other hand, the concrete frame at the end of the building life cycle can be either demolished and landfilled or recycled. Further work could be directed toward studying the impact of the different end-of-life scenarios to the total CO<sub>2</sub> emissions of the two buildings.

An additional benefit of timber, which was not captured by the present LCA, is its property to temporarily store carbon. However, this is outside the scope of this paper, since it largely depends on the origin of the wood and the growth of the wood markets and there is no consensus with respect to the carbon sequestration credits [16].

### 2.3 Additional analysis

#### Cost estimation for load-bearing structure

The costs of the two buildings were estimated on the basis of several quotations of companies offering their products on the Swiss market and using the EAK Swiss cost catalogue [17]. Further, the experience gained from the construction of the post-tensioned timber frame of the *ETH House of Natural resources* supported this work and led finally to a reasonable cost estimation, as reasonable as it could be.

It was found that, given the above described circumstances, the building using the post-tensioned timber structure is about 4% cheaper than a building built with a traditional reinforced concrete structure. This can mainly be explained by the fact that timber has excellent strength to weight ratios which makes it possible to realise the building only with a spread foundation without expensive (money and time) piles. However, it should also be noted that when only the costs of the skeleton system (above ground) is compared, the concrete structure is about 11% cheaper than the post-tensioned timber system, which is in line with earlier studies [18].

As a consequence, buildings using the post-tensioned timber frame structure and thus an eco-friendly material, are not a-priori more expensive than traditional reinforced concrete buildings. The comparison of the costs should include the whole

picture of a building. However, it should also be noted that a building generally built with timber needs a more detailed planning in an earlier planning phase. Further, high quality detailing and exact implementation on site are very important when building with timber.

#### *Construction time*

The two buildings under investigation were further analysed with regard to the construction time. It was assumed that both structural systems are built using a high degree of pre-fabrication allowing for high-quality certified production and a rapid erecting progress. The time for the construction of the structural system built with traditional reinforced concrete was estimated to be about two years considering the documented experience gained from different buildings in Switzerland, namely Roche Bau 1, ETH House of natural Resources, and Aquila-Pratteln.

Since the timber building can be constructed without pile foundation and further without any on-site concreting (e.g. of the floors) except for the core, the construction time of the timber structure can be reduced enormously. It was found that the timber building can be handed over to the building owner in the order of 5 months earlier than the concrete building. However, the core from concrete limits the construction time of the timber building. If the core of the timber building is realised in, e.g., cross-laminated timber (CLT) the construction time of the timber building could be further reduced.

### 3 CONCLUSION

The paper shows a comparable analysis of two high-rise buildings using a skeleton system from timber (post-tensioned timber frame structure) and traditional reinforced concrete. Both buildings were designed as functionally equivalent in order to determine a most reasonable comparison. On the basis of a preliminary structural design of the building a cradle-to-gate Life Cycle Assessment (LCA) was performed. The LCA showed that the post-tensioned timber frame structure contributes about 44% less on greenhouse gas emissions compared to the traditional reinforced concrete structure. Additionally, it was found that for our particular case the costs of the timber building are in the same range as for the concrete building. This can in particular be addressed to the foundation systems; the concrete building needs pile foundation whereas the timber building can be realised with a spread foundation.

It could further be shown that the timber building can be constructed much faster due to the high degree of pre-fabrication, which is typical for timber buildings.

### 4 ACKNOWLEDGMENTS

The authors gratefully acknowledge the financial support by Climate-KIC.

### 5 REFERENCES

1. Horvath, A., Construction materials and the environment. *Annu Rev Energy Env*, 2004. 29: p. 181-204.
2. Wanninger, A., Post-tensioned timber frame structures. PhD thesis no 22815, Institute of Structural Engineering, ETH Zurich, 2015.
3. Brandschutzvorschriften VKF 2015, available online <http://www.vkf.ch/VKF/Services/Brandschutzvorschriften.aspx>, last access on 22.02.2016.
4. SIA (2003): SIA 261: Einwirkungen auf Tragwerke. Schweizerischer Ingenieur- und Architektenverein, Zürich.
5. SIA (2013): SIA 262: Betonbau. Schweizerischer Ingenieur- und Architektenverein, Zürich.
6. Sandin, G., et al., The method's influence on climate impact assessment of biofuels and other uses of forest biomass. Report No 2015:10, f3. 2015. The Swedish Knowledge Centre for Renewable Transportation Fuels, Sweden. Available at [www.f3centre.se](http://www.f3centre.se).
7. Peñaloza, D., et al., Challenges for the use of Life Cycle Assessment as a decision-making tool in building design- the Wälluden case study. In 6th International Conference on Life Cycle Management, 2013: Gothenburg, Sweden.
8. Gustavsson, L., et al., Carbon dioxide balance of wood substitution: comparing concrete- and wood-framed buildings. Mitigation and adaptation strategies for global change 2006, 11(3): p. 667-91.
9. John, V. and Habert, G., Where is the embodied CO<sub>2</sub> of buildings mainly located? Analysis of different types of construction and different views of the results, in World Sustainable Building Conference, 2014: Barcelona, Spain. P. 528-536.
10. ISO 14040:2006. Environmental management – life cycle assessment – principles and framework. 2006, DIN Deutsches Institut für Normung, Berlin.
11. ISO 14044:2006. Environmental management – life cycle assessment – Requirements and guidelines. 2006, DIN Deutsches Institut für Normung, Berlin.
12. Solomon, S., et al., Climate change 2007- the physical science basis: Working group I contribution to the fourth assessment report of the IPCC (Vol. 4). 2007, Cambridge University Press.
13. Kellenberger, D., et al., Life cycle inventories of building products, data v2.0.ecoinvent report No. 7. 2007, EcoInvent

Swiss Centre for Life Cycle Inventories: Dübendorf.

14. Eco-bau, Durabilité et construction publiques. Minergie-Eco®. Construire durable avec Minergie-Eco®.Infos pour les professionnels du bâtiment. 2011.

15. Zea Escamilla, E. and Habert, G., When CO<sub>2</sub> counts: Sustainability assessment of industrialized bamboo as an alternative for social housing programs in the Philippines. *Build Environ*, 2016. 103: p. 44-53.

16. Vogtländer, J. G., et al., Carbon sequestration in LCA, a proposal for a new approach based on the global carbon cycle; cases on wood and on bamboo. *Int J Life Cycle Assess* 2014, 19(1): p. 13-23.

17. Elementarten-Katalog EAK: Vom Baubeschrieb bis zur Abrechnung, Access via <http://www.crb.ch> (last access 25.02.2016).

18. Smith T. J. .Feasibility of Multi Storey Post-Tensioned Timber Buildings: Detailing, Cost and Construction, MSc thesis, University of Canterbury, New Zealand, 2008.





## Expanding Boundaries: Systems Thinking for the Built Environment

### A NEW ROUTE FOR SELF-COMPACTING CLAY CONCRETE

G. Landrou<sup>1\*</sup>, C. Brumaud<sup>1</sup>, G. Habert<sup>1</sup>

<sup>1</sup> ETH Zürich, Chair of Sustainable Construction, Stefano-Franscini-Platz 5, 8093 Zürich, Switzerland

\*Corresponding author; glandrou@ethz.ch

#### Abstract

In the construction sector, cement use is responsible for 8% of the total CO<sub>2</sub> emission and this value will increase with respect to the global population growth. An urgent need to develop a sustainable constructive material for future generations became a challenge. Without transport needs and with infinite recycling possibilities, earth is one of the building materials with the lowest environmental impact. However, its development is hindered by the time and the manpower required in conventional earthen construction techniques.

To develop a self-compacting clay concrete, a material as easy and as cheap to use as current concrete products, we have improved the earth paste flow properties through the dispersion, coagulation and the control of combined reactions. In this study, rheological and zeta potential measurements show that sodium silicate adsorbed onto a clay surface allows the deflocculation of clay based concrete and their adsorption leads to a repulsion force. Using more natural minerals as calcium hydroxide that dissolve slowly in the pore solution allows the precipitation of C-S-H that annihilates the dispersant effect and delays the coagulation.

As conclusion, we developed an innovative process for an eco-friendly self-compacting earth, which is a very promising technology for affordable and low carbon dwellings. We used efficient clay admixtures combined with coagulants in order to have an easy casting material which delays the setting. This process, which allows to reduce manpower, cost and time, is possible through a knowledge transfer from cement chemistry, concrete technology and ceramic science into earthen architecture.

#### Keywords:

Rheology; zeta potential; C-S-H; earthen architecture; eco-friendly

### 1 INTRODUCTION

Traces of earthen architecture date back to 10'000 years ago and earth is still used as a building material in most climates and societies [1]. Without transport and with infinite recycling possibilities, earth is one of the building materials with the lowest environmental impact [2, 3]. Additionally, it provides an efficient temperature and moisture regulation of indoor living spaces [4]. We can currently observe a strong development of earth construction due to environmental concerns. However, this development is limited as the conventional earth construction technique is time and cost intensive. On the other hand, we have cement, which is an incredibly easy to use material but that has a significant environmental impact [5]. In the latter

material, a lot of engineering and science has been invested in order to improve the understanding and the processing of cement based concrete, whilst in the case of earth no or very little engineering improvements have been made.

The objective of this study is therefore to transform earthen architecture by providing a material that is as easy and as cheap to use as current concrete products, thanks to novel technologies borrowed to science and technology of cement and concrete. This technology transfer can be done as cement and clays have a lot of analogies in terms of colloidal interactions and adhesion forces, even if the cohesion forces between particles are much weaker for clay

particles [6] due to the difference of constitute binder (no hydraulic reaction occurs).

To improve the material workability, a careful control of the rheology of the clays requires a better understanding of colloidal interactions between particles and knowledge transfer from the fundamental physics of grain and colloidal interactions to civil engineering [7, 8]. As unique binder in earth, clay, an inorganic negatively charged particle, can have its surface interaction changed with the help of organic dispersants coming from cement and ceramic industries. Among dispersants commonly used in ceramic processing, sodium silicate is known to guarantee an efficient dispersion of natural clay materials [9, 10]. On the contrary clay flocculation can be achieved through the introduction of  $\text{Ca}^{2+}$  ions coming from the dissolution of natural minerals containing calcium. These ions interact both with the surface of clay particles and with the deflocculant anions [10, 11, 12].

In this paper, we focus on the modification of clay properties with inorganic additives in order to deflocculate and flocculate the clays during the casting process. We highlight the ability of sodium silicate to deflocculate clay particles and thus to fluidify the earth material by reducing the yield stress. Moreover, the ability of calcium to reflocculate clay particles is highlighted, through the formation of soluble products annihilating the effect of the dispersant.

## 2 EXPERIMENTAL

### 2.1. Materials

The earth, purchased from Stroba®, used in this study has a specific density of 2.72 and a specific surface area SBET = 46.9 m<sup>2</sup>/g. The mean size of the earth, measured using a laser particle size analyser (LA-95, Partica Retsch Technology), is 8.7 µm. It contains 95% of fine particles (< 63 µm), including clays (36.6wt% by mass). Its chemical composition obtained by X-ray fluorescence spectrometry (XRF) is given in Table 1. The X-ray powder diffraction technique revealed that the main mineralogical components are smectite (24wt%), quartz (41wt%) and a lower amount of kaolinite (7.5wt%). When prepared as a suspension, earth develops a pH

of the order of 9. The dispersant investigated in this study is an inorganic deflocculant taking from ceramic industry: sodium silicate (noted here NaSil) solution from Sigma Aldrich with a composition of 10.6% Na<sub>2</sub>O and 26.5% SiO<sub>2</sub>. Calcium hydroxide (CaOH<sub>2</sub>) from Fulka was used as coagulant additive.

### 2.2. Experimental Process

**Rheology measurements** were carried out on earth pastes in order to study the effect of dispersants on the rheological properties of the suspension such as the yield stress. To compare the results obtained from different measurements, the Water to Earth ratio (W/E) for earth pastes was kept constant (0.5). Only the dosage of the dispersant was varied from one sample to another. In this paper, all dosages are expressed as a percentage of the mass of solids in the system and water is deionized. The tested earth pastes were prepared using the following mixing procedure: the dispersant is added to the required amount of mixing water in order to ensure its dissolution before introduction into the solid phase. Water (with or without dispersant) is mixed with earth during 3min at 365rpm with a mechanical stirrer. The rheology measurements were carried out using a MCR501 Anton Paar® stress controlled rheometer equipped with a Vane geometry [13]. Twenty minutes after the first contact of constituents (including the mixing phase), the cup of the rheometer was filled, covered to limit evaporation and the sequence was started. After a one minute pre shearing phase, a constant shear rate of 0.01 s<sup>-1</sup> is applied to the sample for 10 min. At this low shear rate, viscosity effects are negligible and yield stress can be computed from the measured torque peak value at flow onset.

**Viscoelastic properties** were determined from oscillatory tests by applying a sinusoidal input stress and recording the subsequent sinusoidal shear stress. The elastic modulus  $G'$  and the critical shear strain  $\gamma_c$  of the pastes were determined as functions of applied stress (from 0.1 to 3000 Pa) at an oscillation frequency of 1Hz. The critical strain was defined as the strain at the end at the linear elastic regime [14], where elastic modulus falls to 90% of the plateau value.

SiO <sub>2</sub>	TiO <sub>2</sub>	Al <sub>2</sub> O <sub>3</sub>	Fe <sub>2</sub> O <sub>3</sub>	K <sub>2</sub> O	MgO	CaO	Others	Loss Ignition
65.80%	1.19%	14.91%	7.43%	2.38%	1.08%	1.13%	0.93%	5.02%

Table 1: Chemical composition of the earth studied here.

**The  $\zeta$ -potential**, which is the electrokinetic potential in colloidal systems and thus the key indicator of the stability of dispersions, of the concentrated suspensions of earth was measured with the ZetaProbe (Colloidal Dynamics®) [15]. The  $\zeta$ -potential experiments were carried out on suspensions of solid volume fractions around 6 wt% to avoid sedimentation issues and measurement artefact. Dispersant dosages were kept the same as those used in the rheology measurement.

**The mineralogical composition** of the formed reaction products was determined on randomly oriented powder specimens using X-ray diffraction (XRD). The sample was milled in ethanol to a grain size below 20  $\mu\text{m}$  then dried at 65°C and homogenized. XRD measurements were made using Bragg–Brentano geometry (Bruker AXS D8 advance, CuK $\alpha$  radiation). The powder samples were step-scanned at room temperature from 2 to 80° 2 $\Theta$  [16].

### 3 RESULTS AND DISCUSSION

**To understand the effect of dispersant on earth product**, we plot in Fig. 1 the yield stress as a function of dispersant dosage for earth paste prepared with NaSil. As expected, when the dispersant is added, the yield stress of the earth paste is strongly reduced. As the rheological behaviour of clay suspensions is controlled by their surface charge, this can be attributed to the deflocculating action of the dispersant that modifies the clay surface [9, 10]. We observe in Fig. 1 that the yield stress becomes constant from 0.3% of NaSil. We can thus estimate that the saturation dosage is reached for this dispersant. Above it, all the particle surface is expected to be covered and the dispersant is no longer efficient. With these results, we determine the required dosage of NaSil to deflocculate the clay paste as much as needed, while still displaying a sufficient yield stress to ensure stability and homogeneity. Moreover, the  $\zeta$ -potential measurement gives an indication of the surface charge of the clay particles in suspension. It is often used as a measure of the strength of the repulsive interactions between similarly charged particles in suspensions. The same approach has been applied to evaluate electrostatic forces between our clay particles.

The  $\zeta$ -potential values measured for the reference paste and the one prepared with 0.3% of NaSil are gathered in Tab. 2. In deionized water, the  $\zeta$ -potential of the earth sample is negative due to its negative surface charge.

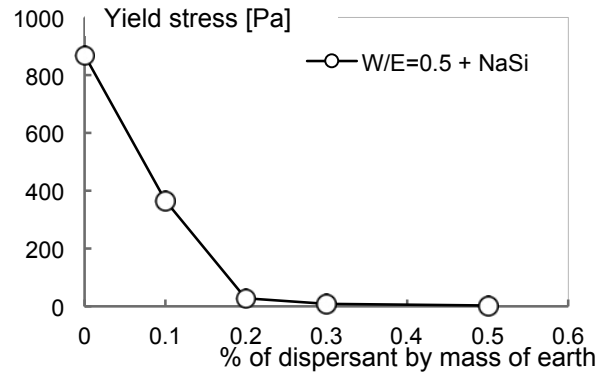

Fig. 1: Effect of NaSil on the yield stress of earth paste.

	Reference	0.3% NaSil
Average $\zeta$ [mV]	-4.6	-9.7
SD [mV]	$\pm 0.1$	$\pm 0.2$

Table 2:  $\zeta$ -potential values for the reference earth and the one prepared with 0.3% of NaSil.

The addition of 0.3% of NaSil increases its magnitude by a factor close to two. This result supports the interpretation that this inorganic dispersant deflocculates clay particles by increasing repulsive forces between particles. However, important other aspects as the ionic strength of the medium and possible steric effects would have to be checked in order to confirm this.

Once the deflocculation achieved, in order to accelerate the removal of formwork, calcium hydroxide  $\text{Ca}(\text{OH})_2$  was introduced into the mix earth/dispersant in order to study its effect on the rheology of the material, and its potential ability to flocculate particles. For this, the dosage was calculated so as to introduce the same amount of calcium in the system. The ratio Ca/Si was fixed at 1.3. The calcium containing compound was introduced in powder form after the mixing of water with earth.

We follow the storage or elastic modulus of the earth paste containing dispersant and  $\text{Ca}(\text{OH})_2$  as a function of time. As a main observation, the elastic modulus increases with time. This first observation shows that the used of calcium modifies the internal structure and cohesion of the material. Adding calcium flocculates the system. Andreola *et al.* [9] reports that dissolved  $\text{Ca}^{2+}$  ions have deleterious effects on dispersing clay materials by: (i) adsorbing onto the clay surface, reducing the thickness of the electrical double layer; (ii) decreasing the amount of silicate anions available to be adsorbed on clay edges through soluble complex formation. By complexation with calcium ions  $\text{Ca}^{2+}$ , a network

of interaction is created between particles and gives rise to cohesion forces within the system.

In Fig. 2, we plot the elastic modulus as a function of strain for the reference earth paste, the one prepared with 0.3% of NaSil and the

same earth paste containing  $\text{Ca}(\text{OH})_2$ . The critical strain  $\gamma_c$  for the earth paste prepared with 0.3% of NaSil is of the order of 15% whereas the critical strain  $\gamma_c$  for the two others earth pastes is of the order of 1%.

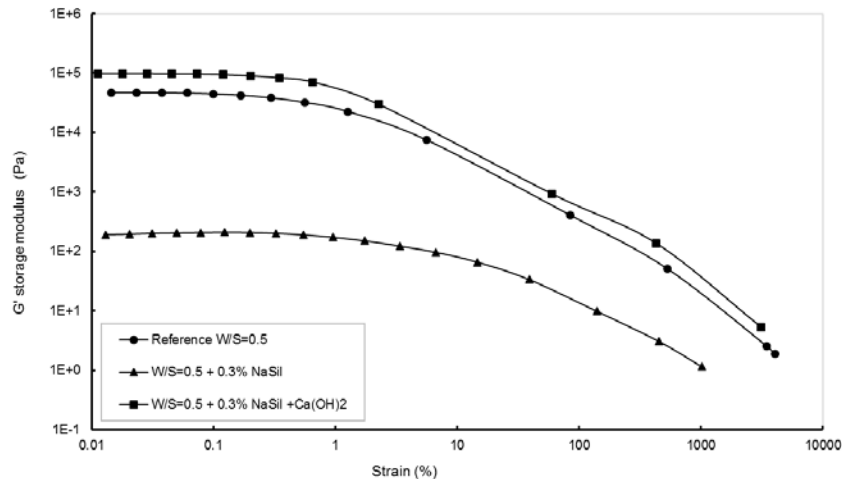

Fig. 2: Elastic modulus as a function of strain for the reference earth paste, the earth paste prepared with 0.3% of NaSil and the same earth paste containing  $\text{Ca}(\text{OH})_2$  after setting.

When the critical strain is reached, the initial structure of the material has been sufficiently modified to produce the rupture of the network of particle interactions [17, 18]. The order of magnitude of the critical strain highlights the ability of the structural network to be deformed under stress and defines the nature of interactions. While a low critical strain had to be associated with short-range links between the particles, a high critical strain involves non-contact interactions between the particles: it implies rather large movement and deformation of two neighbouring particles [19]. In cement suspensions, it has been shown that the large critical strain (on the order of a few  $10^{-2}$  in the case of cement particles) can be associated to the breakage of the network of colloidal interactions (*i.e.* van der Waals attractive forces) between particles. It is thus possible to suggest that strong but short ranged colloidal interactions are at the origin of the cohesion of the earth paste. When 0.3% of NaSil is added to the earth material, the critical strain increases whereas the elastic modulus decreases, and the material is able to be more deformed under stress than the reference paste, indicating that the interaction network between particles is long ranged. This observation suggests that NaSil modifies the van der Waals attractive force network at the origin of this critical strain. We can therefore suggest that the adsorbed NaSil is at the origin steric repulsive forces between particles, leading to a strong dispersion of the particles into the suspension [20]. By steric hindrance effect, the surface-

particles increases and direct particle contacts are replaced by soft distant contacts. A network of soft interactions gets them in contact to create a stable and cohesive medium, leading to, at macroscopic scale, a significant critical strain. Given that the initial state is recovered, the internal structure and the type of interactions of the material are not modified: after deflocculating the particles with the use of dispersant, they reflocculate to their initial form under the effect of calcium. The fact that we observe an equivalent critical strain suggests that calcium addition annihilates the plasticizing effect of the dispersant by removing it from the clay surface or modifying its dispersing ability on those surfaces. The amount of calcium introduced into the mixture corresponds to Ca/Si ratios frequently used for producing synthetic C-S-H. It is therefore most probable that the dispersant has been consumed by the precipitation of C-S-H products into the interstitial solution. It may either be removed for the surface or present there as C-S-H, contributing to cohesion rather than dispersion.

**The peak identification of XRD patterns** shows the precipitation of two phases: formation of plombierite, a gel like structure member of calcium silicate hydrate (C-S-H) family, and sodium carbonate (Fig.3). Plombierite named Tobermorite 14Å with a chemical composition  $\text{Ca}_5\text{Si}_6\text{O}_{16}(\text{OH})_2 \cdot 8\text{H}_2\text{O}$  is the most hydrated phase of C-S-H group [21, 22]. At 3 minutes,  $\text{Ca}(\text{OH})_2$  peaks can still be identified, but after 3hrs of mixing,  $\text{Ca}(\text{OH})_2$  peaks have disappeared and C-S-H peaks are more dominant. Additionally, the

SEM image shows typical needles network of C-S-H after 3 hours. This result confirms the previous hypothesis concerning the mechanism of coagulation of the soil by addition of a calcium-containing mineral: the formation of C-S-H as an

anti-plasticizer. Moreover, the process involves a coupling of portlandite dissolution and C-S-H precipitation, which delays the coagulation process giving open time for processing and casting the earth paste in fluid state.

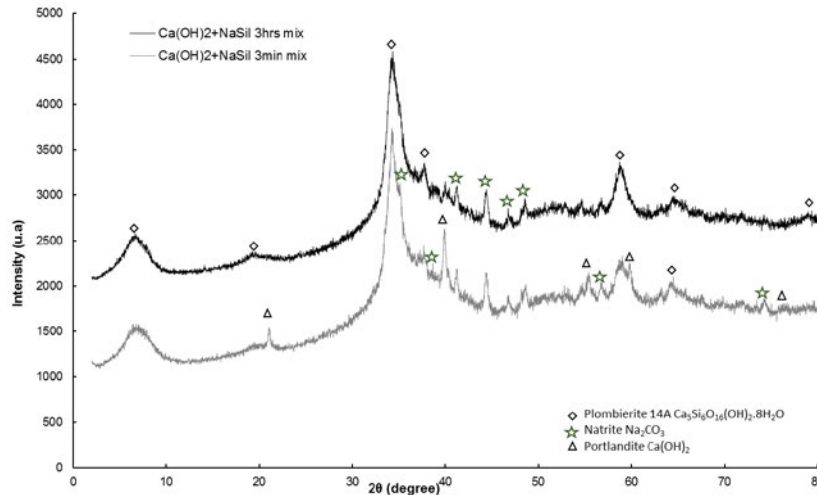

Fig. 3: X-ray diffraction patterns of sodium silicate solution and calcium hydroxide at different mix dried at 60°C and 50mbar.

#### 4 CONCLUSIONS

Strategies that have been tested are promising and allow developing a process to cast a clay based concrete as easily as a cement bound concrete. Through a modification of clay properties with inorganic additives and a calcium containing mineral, it is possible to deflocculate and flocculate clays during the casting process.

The use of sodium silicate as dispersant leads to a strong deflocculation of clay particles by creating repulsive forces between particles. The yield stress of the earth material is then considerably reduced and a good workability is obtained as required to pour the material in the formwork.

Furthermore, we showed that the addition of calcium hydroxide can reflocculate clay particles, through a slow dissolution that releases calcium ions into the interstitial solution, which macroscopically brings the earth material back to its initial behaviour. The released calcium ions lead to C-S-H precipitating with the silicate dispersant, which cancels the plasticizing effect. In this process, C-S-H precipitation is not used as a binding agent but as an anti-plasticizer that removes the inorganic dispersant additives.

#### 5 ACKNOWLEDGEMENTS

Financial support by the Swiss National Fund (SNF) is gratefully acknowledged (project N°. 205121-153368, SCCC – Self Compacted Clay based Concrete).

#### 6 REFERENCES

1. Anger R. and Fontaine L., *Bâtir en terre: du grain de sable à l'architecture*. Ed. Belin, 2009. p. 223.
2. Morel J. C., Pkla A., Walker P., *Compressive strength testing of compressed earth blocks. Construction and Building Materials*, 2007. 21, 303.
3. Shukla A., Tiwari G. N., and Sodha M. S., *Embodied energy analysis of adobe house. Renewable Energy*, 2009.34(3): p. 755–761.
4. Parra-Saldivar M. L. and Batty W., *Thermal behaviour of adobe constructions. Building and Environment*, 2006. 41(12), p. 1892–1904.
5. Schneider M., Romer M., Tschudin M., and Bolio H., *Sustainable cement production—present and future. Cement and Concrete Research*, 2011. 41(7): p. 642–650.
6. Pellenq R. J.-M., Lequeux N., and van Damme H., *Engineering the bonding scheme in C–S–H: The ionic-covalent framework. Cement Concrete Research*, 2008.38(2):p. 159–174.
7. Kovler K. and Roussel N., *Properties of fresh and hardened concrete. Cement and Concrete Research*, 2011.41(7): p. 775–792.
8. Yamine J., Chaouche M., Guerin M., *et al.*, *From ordinary rheology concrete to self compacting concrete: A transition between frictional and hydrodynamic interactions. Cement and Concrete Research*, 2008. 38, p. 890–896.

9. Andreola F., Castellini E., Lusvardi G., Menabue L., Romagnoli M., Role of the surface treatment in the deflocculation of kaolinite. *Journal of the American Ceramic Society*, 2006. 89, p. 1107–1109.
10. Andreola F., Castellini E., Lusvardi G., Menabue L., Romagnoli M., Release of ions from kaolinite dispersed in deflocculant solutions. *Applied Clay Science*, 2007. 36(4), p. 271-278.
11. Mporfu, P., Addai-Mensah, J., Ralston, J., Influence of hydrolysable metal ions on the interfacial chemistry, particle interactions, and dewatering behavior of kaolinite dispersions. *Journal of Colloid and Interface Science*, 2003. 261, p. 349–359.
12. Adebowale, K.O., Unuabonah, I.E., Olu-Owolabi, B.I., Adsorption of some heavy metal ions on sulphate- and phosphate-modified kaolin. *Applied Clay Science*, 2005. 29, p. 145–148.
13. Nguyen Q. D. and Boger D. V., Yield stress measurement for concentrated suspensions. *Journal of Rheology*, 1983. 27, p. 321-349.
14. Nachbaur L., Mutin J.C., Nonat A., Choplin L., Dynamic mode rheology of cement and tricalcium silicate pastes from mixing to setting. *Cement and Concrete Research*, 2001. 31(2), p. 183-192.
15. Zingg A., Winnefeld F., Holzer L., Pakusch J., *et al.*, Adsorption of polyelectrolytes and its influence on the rheology, zeta potential, and microstructure of various cement and hydrate phases, *Journal of Colloid and Interface Science*, 2008. 323, p. 301-312.
16. Bish DL, Plötze M. X-ray powder diffraction with emphasis on qualitative and quantitative analysis in industrial mineralogy. In: Christidis editor, *Ind Mineral EMU Notes in Mineralogy*, 2011. p. 35–76
17. Roussel N., Lemaître A., Flatt R.J., Coussot P. Steady state flow of cement suspensions: a micromechanical state of the art. *Cement and Concrete Research*, 2010. 40, p. 77–84
18. Maloney C.E., Lemaitre A., Amorphous systems in athermal, quasistatic shear. *Physical Review E*, 2006. 74, 016118
19. Roussel N., Ovarlez G., Garrault S., Brumaud C. The origins of thixotropy of fresh cement pastes *Cement and Concrete Research*, 2012. 42(1): p. 148-157.
20. Flatt R.J., Dispersion forces in cement suspensions. *Cement and Concrete Research*, 2004. 34, p. 399–408.
21. Nonat, A., The structure and stoichiometry of C-S-H. *Cement and Concrete Research*, 2004. 34(9): p. 1521-1528.
22. Bonaccorsi, E., Merlino S., Taylor H.F.W., The crystal structure of jennite,  $\text{Ca}_9\text{Si}_6\text{O}_{18}(\text{OH})_6 \cdot 8\text{H}_2\text{O}$ . *Cement and Concrete Research*, 2004. 34(9): p. 1481-1488.



## Expanding Boundaries: Systems Thinking for the Built Environment

### IMPROVING RAMMED EARTH WALLS' SUSTAINABILITY THROUGH LIFE CYCLE ASSESSMENT (LCA)

A. Arrigoni<sup>1\*</sup>, D. Ciancio<sup>2</sup>, C.T.S. Beckett<sup>2</sup>, G. Dotelli<sup>1</sup>

<sup>1</sup> Politecnico di Milano, Dipartimento di Chimica, Materiali e Ingegneria Chimica, Piazza Leonardo da Vinci 32, Milano, 20133, Italy

<sup>2</sup> The University of Western Australia, School of Civil & Resource Engineering, 35 Stirling Highway, Perth, WA 6009, Australia

\*Corresponding author; e-mail: [alessandro.arrigoni@polimi.it](mailto:alessandro.arrigoni@polimi.it)

#### Abstract

Rammed earth, an ancient construction technique based on compacting soil in progressive layers into formwork, has recently seen renewed interest due to its low environmental impact compared to traditional wall systems. However, the choice of soil and the addition of stabilisers to improve material durability and strength could jeopardize these environmental benefits. The focus of this paper is the lifecycle environmental impact of a typical rammed earth wall in Perth, Western Australia. The goal is to estimate variation in the structure's sustainability according to the materials used. Several soil mixtures, conventional and innovative ones, as well as recycled and waste materials (e.g. recycled concrete, fly ash and carbide lime) were considered for the analysis. Durability tests were performed to compare specimens' mechanical performance and their resistance to erosion. The sustainability analysis of the building material is therefore extended from the construction phase to the entire lifecycle, as recommended by the LCA standards. Results indicated that the choice of the mixture's components and their source could significantly affect the overall environmental performance of the structure. Even though every soil has different characteristics, materials similar to the ones considered here could be sourced anywhere and the results could be adapted to different geographical areas.

#### Keywords:

rammed earth; LCA; sustainable building materials; durability; waste materials

### 1 INTRODUCTION

Rammed Earth (RE) is an ancient construction technique based on the compaction of soil in progressive layers into formwork. The perception that the use of natural materials is environmentally benign has led to a renaissance of this building technique. Soil traditionally used for RE buildings is unstabilised and has an adequate proportion of inert aggregate fraction (sand and gravel) and a binder fraction (silt and clay) [1]. Nowadays, stabilisers are generally added to the earth mixture to improve the wall strength and the resistance to erosion. The incorporation of Portland cement is very common in Australia, where stabilised RE housing has gained popularity in recent years. However, cement stabilisation reduces the sustainability of RE

buildings [2-4] and alternative stabilisers have been tested in the past decades. The main alternative to cement is lime, but the use of waste materials, biopolymers, geopolymers and fibres have been investigated as well in the literature (e.g. [5-7]). Most of these studies focus on the mechanical properties of innovative mixtures; even though durability is a main concern for earthen structures [8, 9], it is often not considered together with their environmental performance. In this paper, the lifecycle assessment (LCA) tool is applied to a construction site in Perth, Western Australia (WA), to assess both the environmental performance *and* the durability properties of different stabilised RE mixtures. Results are used to understand whether, in a lifecycle perspective, a longer lifespan of the structure and lower

maintenance costs could offset the higher environmental impacts in the construction phase.

## 2 MATERIALS AND METHODS

### 2.1 Materials

Natural soil is very rarely used in Perth metropolitan area for RE construction, due to its poor grading. Crushed limestone sourced by a local quarry has been adopted, instead, as an alternative artificial soil for RE purposes by RE practitioners in Perth in the last 30 years. It is predominantly used with Portland cement, 5 to 15% by mass of dry crushed limestone. Although crushed limestone is advantageous in terms of consistency and hence quality control, its use entails several environmental impacts arising from the excavation process, the crushing of the rock and the final transport. Here, we study alternative soil mixes in addition to the base case of cement-stabilised crushed limestone.

#### Local Soil (LS)

Local soil (LS) is used in other locations of WA than Perth metropolitan area, where remoteness or lack of quarries make it the only available building material. In the present work we studied the feasibility of using LS obtained from the excavation site of a RE building under construction in Perth metropolitan area. The Particle Size Distribution (PSD) of the local soil showed, as expected, that 96% of the material falls within the sand range (*Figure 1*). The curve does not match the recommendations made in [10] for the selection of a suitable soil for RE construction. In order to use the local soil, both fine particles (binders and/or fillers) and inert fraction bigger than sand (i.e. gravel) had to be added. The resulting “engineered local soil” (ELS) comprised 60% LS, 30% clayey soil (from a quarry situated ca. 130 km away from the LS building site) and 10% gravel (quarry ca. 60 km distant). The PSD of the ELS is shown in *Figure 1*.

#### Waste materials

Several waste materials were considered in this study:

- Recycled Concrete Aggregate (RCA): inert material obtained from the demolition of disused concrete structures in Perth area. The Particle Size Distribution (PSD) obtained by dry sieving is shown in *Figure 1*.
- Class F Fly Ash (FA): residue generated by the combustion of coal in a power station located ca. 200 km away from the considered building site. A chemical analysis has shown that the FA is 58.7% SiO<sub>2</sub>, 27.4% Al<sub>2</sub>O<sub>3</sub>, 8.1% Fe<sub>2</sub>O<sub>3</sub>, 1.6% TiO<sub>2</sub> and 0.9% CaO.
- Carbide Lime (CL): by-product of the generation of acetylene gas through the hydrolysis of calcium carbide. CL is

generated as an aqueous slurry and is composed essentially by calcium hydroxide with minor parts of calcium carbonate, unreacted carbon and silicates. The distance between the acetylene gas production site and the construction site is ca. 20 km.

#### Mixtures overview

Mixes (soil material and stabiliser) used in this study are referred to by the following numbers:

0. Crushed limestone + 10 %\* cement
1. RCA + 10% cement
2. RCA + 5% cement + 5% FA
3. ELS + 5% cement + 5% FA
4. ELS + 5% CL + 25% FA
5. ELS

\* “%” refers to the percentage of dry soil

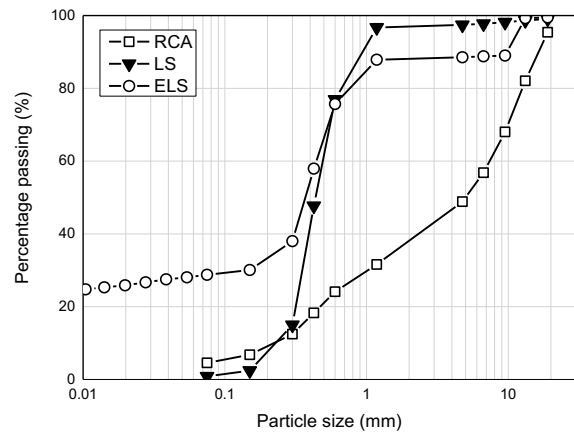

Figure 1: Particle Size Distributions for RCA, LS and ELS.

### 2.2 LCA

#### Methodology

The LCA presented in this paper follows the methodology defined by international norms: ISO 14040 [11] and ISO 14044 [12]. The software SimaPro 8.0.5 was used for the analysis implementation. When waste materials were used in the mixture, neither associated environmental impacts nor benefits were considered. Impacts related to raw material extraction and processing were extrapolated from the Ecoinvent database [13] and the Australasian LCA database [14].

#### Functional Unit

The functional unit considered was the square meter of RE wall. The thickness of the wall considered was 300 mm, which is typical for most RE structures.

#### System boundaries and data quality

The processes considered for the study were:

- Raw material extraction
- Production of mixtures' elements
- Transport of materials to construction site

Since the goal of the study was to compare different mixtures, processes of the wall's lifecycle



independent from the earth mixture were not considered (e.g. materials and machinery used for the wall's erection). As no real case has been found using the same mixtures considered in the study, energy for mixing and for ramming were not included. Further investigation is required to understand how these energies would affect the different mixtures' sustainability. However, in [4] it was concluded that energy expenditure in the compaction process is negligible when compared to energy content of cement. Furthermore, since the focus of this study is limited to the RE component alone, the operational phase of the building (i.e. heating and cooling) was excluded from the study. The choice of the mixture, however, could affect the hygrothermal behaviour of the wall and consequently the energy requirements to reach the comfort of the building's occupants. How the different mixtures affect the overall sustainability of the building will be the focus of a subsequent paper. The end of life of the wall, difficult to forecast, was not included in the assessment.

#### *Impact indicators*

Two midpoint indicators were considered in the study: CML-IA Baseline (characterization factors developed by the University of Leiden) and Cumulative Energy Demand (CED [13]).

### **2.3 Durability tests**

Durability tests allows to include the use phase in the sustainability evaluation of the wall. Since no internationally recognized standard to assess RE's durability is available, several different tests were performed to assess the durability behaviour of the earth mixtures.

#### *Accelerated Erosion Test*

The test consisted of spraying the face of a sample for a period of one hour or until the jet of water spray completely penetrated the sample. The exposed surface was a circular area of 150 mm diameter and the jet of water, projecting at 50 kPa, was placed 470 mm from the sample. The maximum permissible erosion rate for all types of earth construction is one mm per minute [15].

#### *Modified Wire Brush Test*

This test, as presented in *ASTM D559-03* [16], was developed to evaluate the durability of soil-cement mixtures. It determines weight loss, water content change, and volume change (swell and shrinkage) produced by repeated wetting and drying (12 cycles) of compacted specimens. The test has similar conditions to heavy driving rain. Fitzmaurice [17] proposed a weight loss limit of 5% for Compressed Earth Blocks in regions with rainfall greater than 500 mm and 10% otherwise. Some modifications were made to the original test in order to have more representative results.

#### *Unconfined Compressive Strength (UCS)*

Even though UCS is not a durability parameter, its assessment gives information on the overall

material mechanical performance. Moreover, NZS 4298 sets an UCS limit (1.3 MPa) for earthen construction [18]. All specimens ( $\varnothing 100 \times 200$  mm cylinders) were cured for 28 days in a room at constant high humidity (RH:  $96 \pm 2\%$ ) and moderate temperature ( $21 \pm 1^\circ\text{C}$ ) before testing.

## **3 RESULTS AND DISCUSSION**

### **3.1 LCA**

#### *CML-IA Baseline*

CML-IA Baseline results are presented in Figure 2. The phases considered were the extraction and processing of the mixture base components and their transport to the construction site. The studied construction site was located in the centre of Perth. Results show that all mixes were better than the base case (Mix 0) for all the environmental impact categories studied. The impacts related to all the categories, in particular to global warming (see Global Warming Potential (GWP) columns in Figure 2), decreased with the reduction of cement in the mixture. Emissions generated in the clinker production process were the main contributor for all the impact categories except for abiotic depletion, whose main impacts were related to the consumption of chrome in the plating of the steel used in the cement factory and the lead used in the gypsum production process.

When considering the inert fraction, if the binding properties of clay are not required (due to stabilisation), the best environmental solution is to use RCA, which is free of the impacts related to raw material extraction. Using crushed limestone instead of the engineered soil mixture improved performance in all the environmental impact categories, except for the eutrophication and the acidification, because of the shorter distance to the building site of the limestone quarry compared to that of the clay source. Eutrophication and acidification's impacts results are higher because of the emissions generated from the limestone rock blasting process. Nevertheless, if clay's binding properties are not required, recycled fine particles or fillers from closer quarries could be used to drastically reduce the environmental impacts of the mix. On the other hand, clay guarantees binding properties that could reduce the need of cement and lead to better environmental performance. Using RCA (Mix 2) instead of engineered soil (Mix 3) with the same rate of cement stabilisation led to a reduction of 12% in terms of GWP. Using engineered soil with alternative stabilizers (Mix 4) or no stabilisers at all (Mix 5) led to a reduction, compared to the same engineered soil stabilised with cement (Mix 3), of 78% and 83% respectively, always in terms of GWP. The difference would be even greater if cement stabilisation was higher than the 5% (the

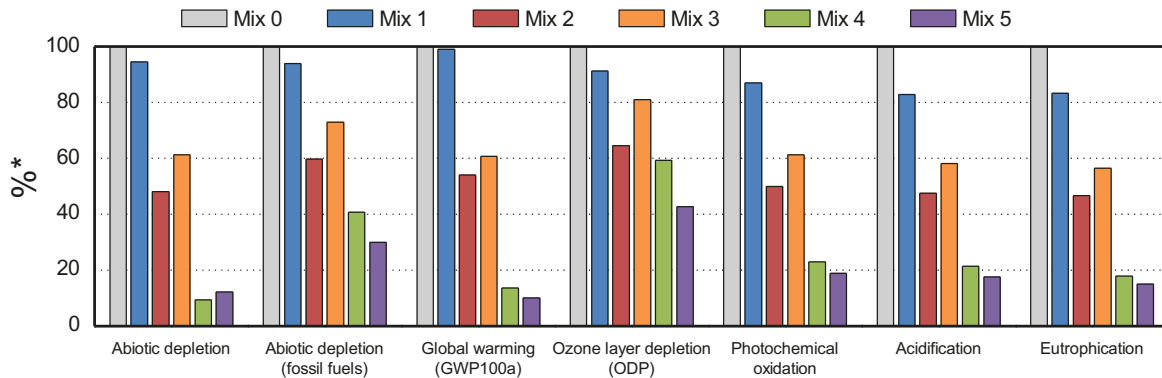

Figure 2: CML-IA results (\*percentage is normalized to the max reached in each impact category).

minimum typically used for RE construction) considered in Mix 3.

#### Cumulative Energy Demand (CED)

CED results are reported in Figure 3. The main contributor for all mixes was the embodied energy of the fossil fuels used both for sintering the clinker and for fuelling the vehicles to transport the materials. Results are therefore consistent with the CML's impact category Fossil Fuels Depletion (see Figure 2). The renewable contribution to the wall's energy demand was very low and derives from the renewable component of the Australian electricity production mix.

### 3.2 Durability tests

#### Accelerated Erosion Test (AET)

Mix 1, Mix 2 and Mix 4 had no visible erosion after one hour. Mix 3 had some minimal localized erosion. Mix 5 was completely penetrated after 40 minutes. All mixes except Mix 5 passed the test.

#### Modified Wire Brush Test (MWBT)

All mixes except Mix 5 (not tested because it would not have resisted a prolonged submersion in water) responded well to the test: all specimens had very low mass losses (lower than 5%), no volume expansion and small increase in water absorption.

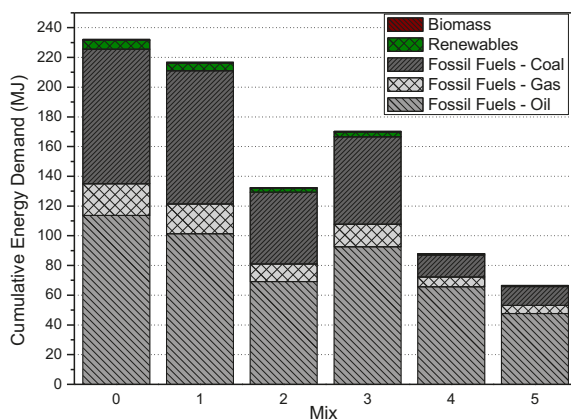

Figure 3: CED results.

Mix	AET	MWBT	UCS
0	n.a.*	n.a.	13.8 MPa [19]
1	pass	pass	8.7 MPa
2	pass	pass	6.7 MPa
3	pass	pass	5.4 MPa
4	pass	pass	2.8 MPa
5	fail	fail	1.3 MPa

Table 1: durability tests results (\*n.a.: not available).

#### Unconfined Compressive Strength (UCS)

The results reported in Table 1 show a reduction of the compressive strength from the base case (highest UCS) to Mix 5 (lowest UCS). According to the results, when cement is used as stabiliser, the use of crushed limestone as base component for the mixture guarantees better mechanical performances than using RCA or the engineered soil. Halving the amount of cement and substituting the part removed with FA led to a UCS reduction of about 23%. The complete elimination of cement and its substitution with CL and FA (Mix 4) led to a significant reduction in UCS, but results remained higher than the limits set by NZS 4298. The UCS of the unstabilised soil (Mix 5) is equal to the NZS limit.

## 4 CONCLUSIONS

- The waste soil gathered from the building foundation's excavation could not be used to make the RE walls due to its poor grading. However, with the addition of the recommended amount of fine and coarse particles, the soil could be used as a base for the RE mixture. The environmental benefits of using the waste soil depend on the amount of material collected, subject to the foundation depth, and especially on proximity of sources of fine and coarse particles; if these sources are far from the building site the environmental benefits could be offset.

- The use of alternative stabilisers had a far higher impact in the reduction of the environmental cost than the impact generated by the alternative choice of aggregates.
- Unstabilised RE (Mix 5) had poor durability test results, although it achieved the minimum UCS required by NZS 4298 for earthen structures. To improve the durability of this mixture, avoiding the use of stabilisers, a sloping roof could be employed (to prevent directly impacting rainfall).
- Among the mixes tested, Mix 4 was very promising. The use of carbide lime and fly ash to stabilise the soil led to a drastic reduction of the environmental impacts, in particular the GWP, in comparison to the base case. Even though the mix has a reduction of 80% in term of UCS, UCS was still adequate to guarantee a safe structural capacity. Mix 4 exhibited good durability properties.
- The choice of the mixture could lead to a variation of the hygrothermal behaviour of the wall. How these changes would affect the environmental impacts of the operational phase of the building (i.e. heating and cooling) will be the discussion topic of a subsequent paper.

## 5 SUMMARY

RE mixtures in WA are generally stabilised with cement to increase their mechanical performances. The goal of this study was to find a sustainable alternative to cement for RE stabilisation. The use of waste and local materials could lead to better environmental performance whilst guaranteeing sufficient mechanical and durability properties.

## 6 ACKNOWLEDGMENTS

The present work has been supported by the Australian Research Council (ARC) through the linkage project LP110100251.

## 7 REFERENCES

1. Minke, G., *Building with Earth: Design and Technology of a Sustainable Architecture*. 2006: Birkhäuser.
2. Owen, C., G.J. Treloar, and R. Fay. *Embodied energy assessment of rammed earth*. in *SOLAR '99 Conference: Opportunities in a Competitive Marketplace*. 1999. Geelong.
3. Maskell, D., A. Heath, and P. Walker, *Comparing the Environmental Impact of Stabilisers for Unfired Earth Construction*. Key Engineering Materials, 2014. **600**: p. 132-143.
4. Venkatarama Reddy, B.V. and P. Prasanna Kumar, *Embodied energy in cement stabilised rammed earth walls*. Energy and Buildings, 2010. **42**(3): p. 380-385.
5. Ciancio, D., C.T.S. Beckett, and J.A.H. Carraro, *Optimum lime content identification for lime-stabilised rammed earth*. Construction and Building Materials, 2014. **53**: p. 59-65.
6. Eires, R., *Construção em Terra: Desempenho melhorado com incorporação de biopolímeros (Building with earth: improved performance with biopolymers incorporation)*. 2012, University of Minho: Guimarães.
7. Pflughoeft-Hasset, D.F., et al., *Use of bottom ash and fly ash in rammed-earth construction*. 2000, University of North Dakota.
8. Morel, J.-C., Q.-B. Bui, and E. Hamard, *Weathering and durability of earthen materials and structures*, in *Modern earth building*. 2012, Woodhead Publishing Limited. p. 282-303.
9. Heathcote, K.A., *Durability of earthwall buildings*. Construction and Building Materials, 1995. **9**(3): p. 185-189.
10. Houben, H. and H. Guillaud, *Earth Construction: A Comprehensive Guide*. 1994.
11. ISO, *ISO 14040:2006 Environmental management -- Life cycle assessment -- Principles and framework*. 2006.
12. ISO, *ISO 14044:2006 Environmental management -- Life cycle assessment -- Requirements and guidelines*. 2006.
13. Weidema, B.P., et al., *The ecoinvent database: Overview and methodology, Data quality guideline for the ecoinvent database version 3*, [www.ecoinvent.org](http://www.ecoinvent.org). 2013.
14. *Australian LCA database (Version 2015.02) developed from 1998 up to 2007 by Centre for Design from data originally developed with the CRC for Waste Management and Pollution Control as part of an Australian Inventory data project*. 2015.
15. Middleton, G.F., *Bulletin 5 - Earth Wall Construction*. 1987, National Building Technology Centre: Chatswood (Australia).
16. ASTM, *ASTM D559-03 Standard Test Methods for Wetting and Drying Compacted Soil-Cement Mixtures*. 1989.
17. Fitzmaurice, R., *Manual on Stabilised Soil Construction for Housing*. 1958, New York: Technical Assistance Programme, United Nations.
18. Standards New Zealand, *NZS 4298: 1998 Materials and workmanship for earth buildings*. 1998: Wellington, New Zealand.
19. Ciancio, D. and J. Gibbings, *Experimental investigation on the compressive strength of cored*

*and molded cement-stabilized rammed earth samples.* Construction and Building Materials, 2012. **28**(1): p. 294-304.



## Expanding Boundaries: Systems Thinking for the Built Environment

### NATURALLY VENTILATED EARTH TIMBER CONSTRUCTIONS

A. Klinge<sup>1\*</sup>, E. Roswag-Klinge<sup>1</sup>, C. Ziegert<sup>1</sup>, P. Fontana<sup>2</sup>, M. Richter<sup>2</sup>, J. Hoppe<sup>2</sup>

<sup>1</sup> Ziegert | Roswag | Seiler Architekten und Ingenieure, Schlesische Strasse 26,  
Aufgang A, 10997 Berlin, Germany

<sup>2</sup> Bundesanstalt für Materialforschung und –prüfung (BAM), Unter den Eichen 87  
12205 Berlin, Germany

\*Corresponding author; e-mail: [klinge@zrs-berlin.de](mailto:klinge@zrs-berlin.de)

#### Abstract

Earth, timber, fibre boards and insulation materials based on wooden and other natural fibres offer a variety of properties beneficial for eco innovative constructions that are able to improve the energy and resource efficiency of buildings.

Due to their porosity, natural building materials are vapour active and are able to buffer moisture. In combination with highly insulated and airtight but vapour permeable building envelopes, modern earth-timber constructions provide stable indoor humidity levels and can therefore be naturally ventilated while achieving highest energy efficiency standards. Experimental evidence suggests that monitored pilot buildings in Berlin do show healthy indoor air humidity levels (around 50%) in wintertime, while mechanically ventilated buildings demonstrate significantly lower values (around 25%), which have to be considered as uncomfortable and unhealthy.

The application of building materials being poor in chemical emissions, particularly volatile organic compounds (VOC) and radon, improves the indoor air quality further, so that intermittent ventilation twice a day will be sufficient to provide healthy indoor air quality. The air quality in critical rooms (e.g. small bedrooms), demonstrating a smaller air volume, should be monitored if appropriate ratios of room size to occupancy level cannot be realised.

Through night time ventilation in summer, vapour active earth-timber constructions provide evaporative cooling (humidity adsorption at night time and desorption during the day). As a result, indoor temperatures of earth-timber buildings range around 8 °C below the outside temperature peak, when an appropriate glazing ratio is reflected.

The EU funded research project H-house is investigating various construction materials regarding water vapour adsorption as well as emission and absorption of harmful substances. Based on this investigation new wall constructions are designed to provide a healthier indoor environment.

#### Keywords:

Climate control through building elements; hygroscopic earthen and wooden materials; natural ventilation; airtight buildings; low emissions

### 1 INTRODUCTION

Occupant's health, wellbeing and also productivity are relying on the indoor air quality of our built environment. Renovated and new low energy buildings, developed to be highly airtight, are demonstrating unforeseen shortcomings with regards to increased relative humidity levels and higher concentration of air pollutants. Reduced air exchange rates increase these problems and are likely to cause damp problems and

condensation resulting in mould growth, and, in the worst case, in disorders and outbreak of allergic reactions.

In addition, the construction of such buildings is often based on lightweight, conventional construction materials resulting in a reduced thermal storage capacity. In combination with an inappropriate glazing ratio, such low energy buildings tend to overheat in summer and compromise occupants thermal comfort.

To overcome difficulties with moisture, dwellings nowadays are fitted with mechanical ventilation systems despite associated constraints such as space requirements, additional costs, system maintenance as well as compromised occupant comfort and control. The main criteria for ventilation are as follows:

- Control of indoor air humidity
- Absence of harmful substances
- Provision of fresh air

In case of protection against overheating in summer the provision of cooling through heat pumps or other active system is often allowed for, resulting in additional energy demand for the operation of the system, increased space requirements and an uplift in construction and maintenance cost.

It is assumed that through application of appropriate materials, the requirements on all aspects mentioned above can be satisfyingly fulfilled.

The EU funded project H-House aims to develop eco innovative partition walls for both renovation and new construction, providing affordable solutions for a wide application. In this study natural building materials have been compared to conventional materials to identify their potential to improve the indoor environment quality, while limiting the use of technology.

Special emphasis was placed on the improvement of earthen plasters by addition of aerogels with regards to both the moisture buffering capacity as well as the adsorption of airborne pollutants. For the moisture adsorption especially velocity and overall moisture uptake were investigated in greater detail.

Comprehensive experiments at material but also at component level have been undertaken to provide a database for the numerical prediction of appropriate material combinations that are able to react to different scenarios, since available surface area, occupation density, air volumes but also the construction of the building envelope might differ significantly between projects.

Accompanying experiments with regards to the emissions of the materials as well as to their potential adsorption of airborne pollutants have been conducted to identify materials that generate the most positive effects on the living environment.

In addition, experimental data coming from the monitoring of a dwelling in Berlin fitted out with earth plasters and wood fibre based partition walls has been evaluated in relation to indoor air temperatures and relative humidity levels.

## 2 MATERIALS AND TEST METHODS

### 2.1 Material selection

The material selection was based on an in-depth market analysis focused on natural building materials for internal partition walls, characterised through hygroscopic properties. In addition, natural building materials with no or limited data collection were shortlisted to close a scientific gap. Special emphasis was placed on earth plasters modified with aerogels. In the experimental campaign, the contribution to the water vapour adsorption of one type of aerogel granulate (CMSGI) and two types of aerogel powder (CMSPI and NDPI) was investigated.

Additional aspects although not presented in this contribution but equally important for the design of innovative partition walls have been investigated and taken into consideration and are:

- Low embodied energy;
- Advanced acoustic properties;
- Durability, cost efficiency.

For benchmarking purposes, also conventional construction materials have been included. In total a selection of approx. 100 materials, grouped into their function of assembly, has been investigated (Table 1).

### 2.2 Water vapour sorption tests

The voluntary test procedure is determined in DIN 18947 [1] to identify the capacity of earth plasters to adsorb moisture from the air via the specimen's surface within set time intervals. The test requires to pre-condition three material samples (50 cm × 20 cm × 1.5 cm) in a climate chamber at a temperature of (23 ± 1) °C and (50 ± 5)% relative humidity (RH) until constant weight is achieved. The RH level is then increased to 80% and the weight of the samples is measured at specific time intervals (0.5 h, 1 h, 3 h, 6 h and 12 h). Based on the results, the water vapour adsorption class of plasters (only) can be classified. The adsorption process is normally conducted for 12 h, however due to an increased material thickness of certain boards but also for wall build-ups the procedure was extended to 72 h (with subsequent desorption) or in case of wall build-ups to 5 adsorption/desorption cycles.

### 2.3 Monitoring

Monitoring data has been obtained from three different flats located in Berlin during August 2012 to September 2012 and during November 2012 to January 2013. The flats were either fitted out with natural or conventional building materials. Measurements were carried out with a miniature sensor and data logging system (iButton®) i-buttons, measuring external temperature, indoor air temperature and internal and external relative humidity [2].

## 2.4 Emission tests

The materials listed in Table 1 were screened for potential emissions prior to the standard tests to estimate the compounds to be expected. Final emission tests ((S)VOCs, radon) for single materials (six types) and 13 combinations of them were carried out in specially designed test chambers over a testing period of 28 days. They

were conducted following the requirements of prEN 16516 [3] and evaluated against the German AgBB scheme [4], in the absence of harmonised evaluation procedures.

Formaldehyde and VOC-analyses were carried out according to ISO 16000-3 and -6 [5], [6] and radon measurements in accordance with a procedure developed by Richter et al [7].

Function	Material	Thickness [mm]
Finishing materials	Earthen paint, marble powder paint, brush applied earth plaster, dispersion paints	0.5 - 2
Render	Aerogel modified earth plaster, earth plaster, lime plaster	3 - 15
Reinforcement	Flax fibre reinforcement, glass fibre reinforcement, system compatible reinforcement	0.5
Adhesive	Earth adhesive, system compatible adhesives	2 - 3
Wall lining boards	Earth dry & cellulose boards, wood fibre and wood fibre sandwich boards, plywood, gypsum plaster & fibre boards, Oriented Structural Straw boards	12.5 - 31
Insulation	Wood fibre insulation boards & mats, flax insulation, hemp insulation boards, sheep's wool, straw, recycled clothes, mineral & glass wool	40 - 80
Internal insulation (external walls)	Wood fibre and wood fibre sandwich boards, calcium silicate and mineral boards	20 - 100
Load bearing walls	Cross laminated timber	100
Non-load bearing, dry lining and solid wall elements (boards or blocks)	Dry lining walls based on wall lining boards (as above), earth blocks, wood fibre insulation blocks with cellulose honeycombs core, wood or gypsum fibre sandwich boards with flax core, compressed straw board, autoclaved aerated concrete	60 - 120

Table 1: Overview of investigated materials.

## 2.5 Adsorption of indoor pollutants

For adsorption tests according to ISO 16000-24 [8] the chamber supply air was spiked with 1-pentanol, hexanal, butyl acetate, n-decane and  $\alpha$ -pinene representing important indoor air contaminants in specified concentrations ranging between 200 and 500  $\mu\text{g}/\text{m}^3$ , being higher than usually measured in indoor air to ensure a distinct determination of the reduction of the test chamber air concentration caused by the material. The air-purifying performance of the material was determined by monitoring the difference of the inlet and outlet concentration of the test chamber. Tests were carried out for more than 9 materials (six single earth plasters with and without aerogel addition, three multi-layer specimens composed of different materials).

plasters are characterised through an outstanding water vapour adsorption capacity, which is up to 3 times higher in comparison to gypsum plasterboards, as evidenced also in [9], [10]. Also earth dry boards, earth cellulose and wood fibre boards demonstrate exceptional moisture buffering potential. Gypsum fibre boards range between earth plasters and gypsum plaster boards.

Additional tests have been performed for other single layered materials, but also at component level, investigating the potential of entire wall build-ups not only for the immediate moisture uptake but also their potential to provide a comfortable and healthy environment due to seasonal changes. An overview of the most relevant results is presented in Fig. 3. Materials were tested in the most common thickness used for standard partition wall applications and although they differ, a direct comparison of specimens seems useful to identify the most capable materials and their combination.

## 3 RESULTS

### 3.1 Water vapour sorption tests

Experimental results shown in Fig. 1 and Fig. 2 demonstrate that modified and pure earth

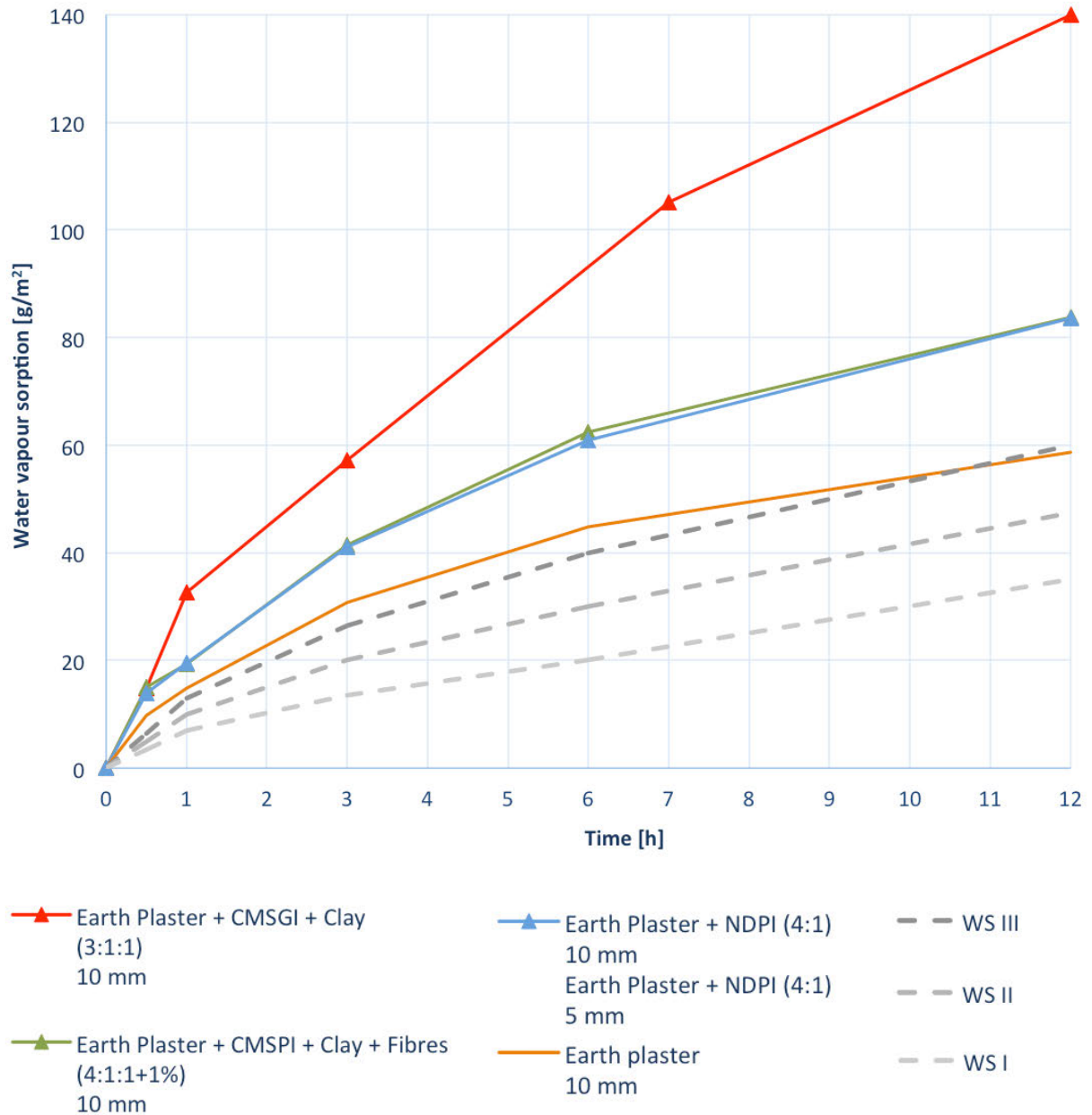

Fig. 1: Results of water vapour adsorption tests (DIN 18947) of modified and pure earth plasters (mix proportions by weight).



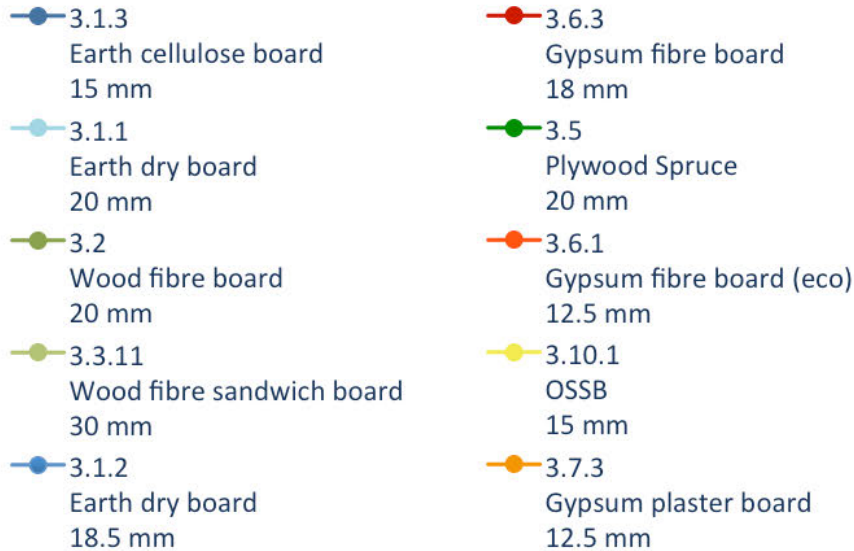
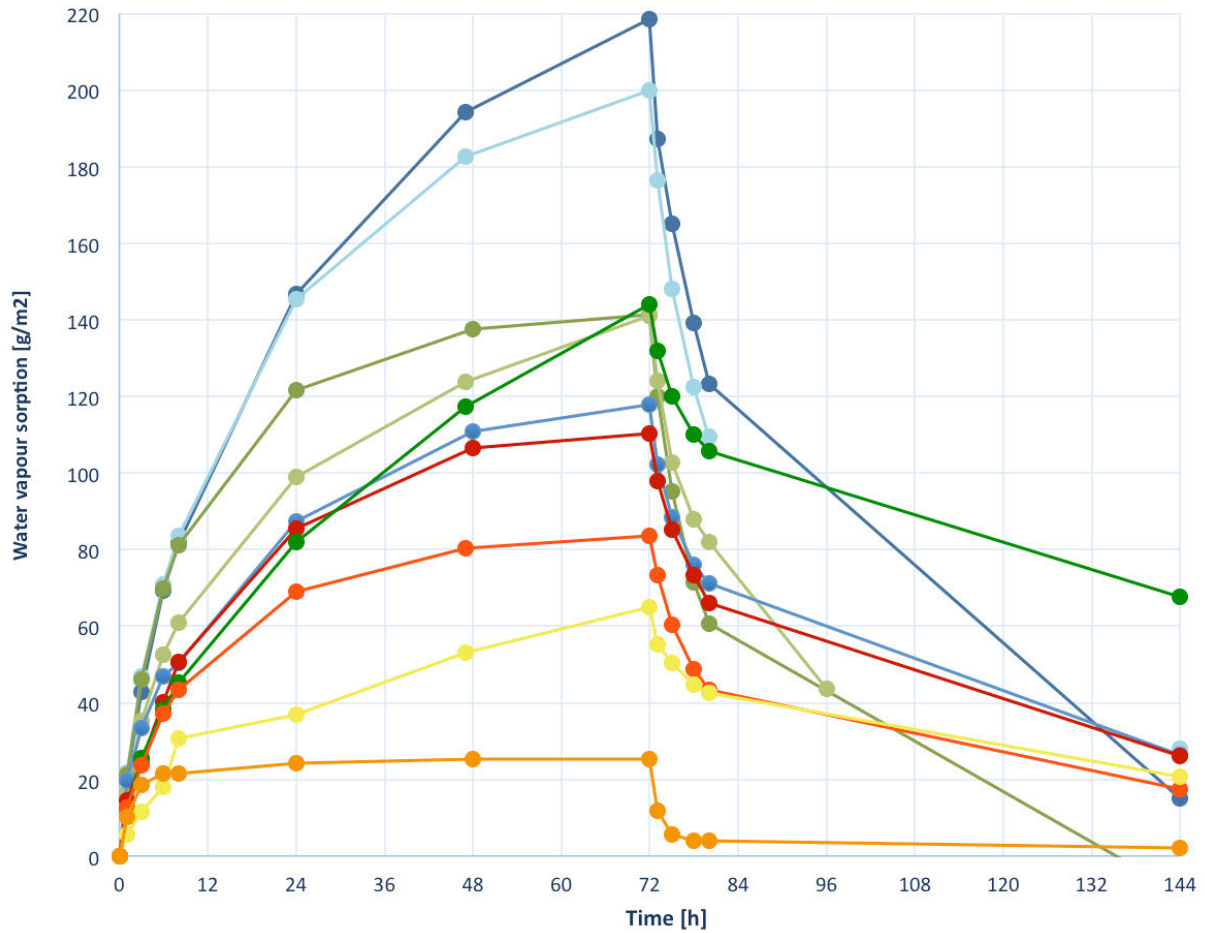

Fig. 2: Results of water vapour adsorption tests (72h) with subsequent desorption of wall lining boards.

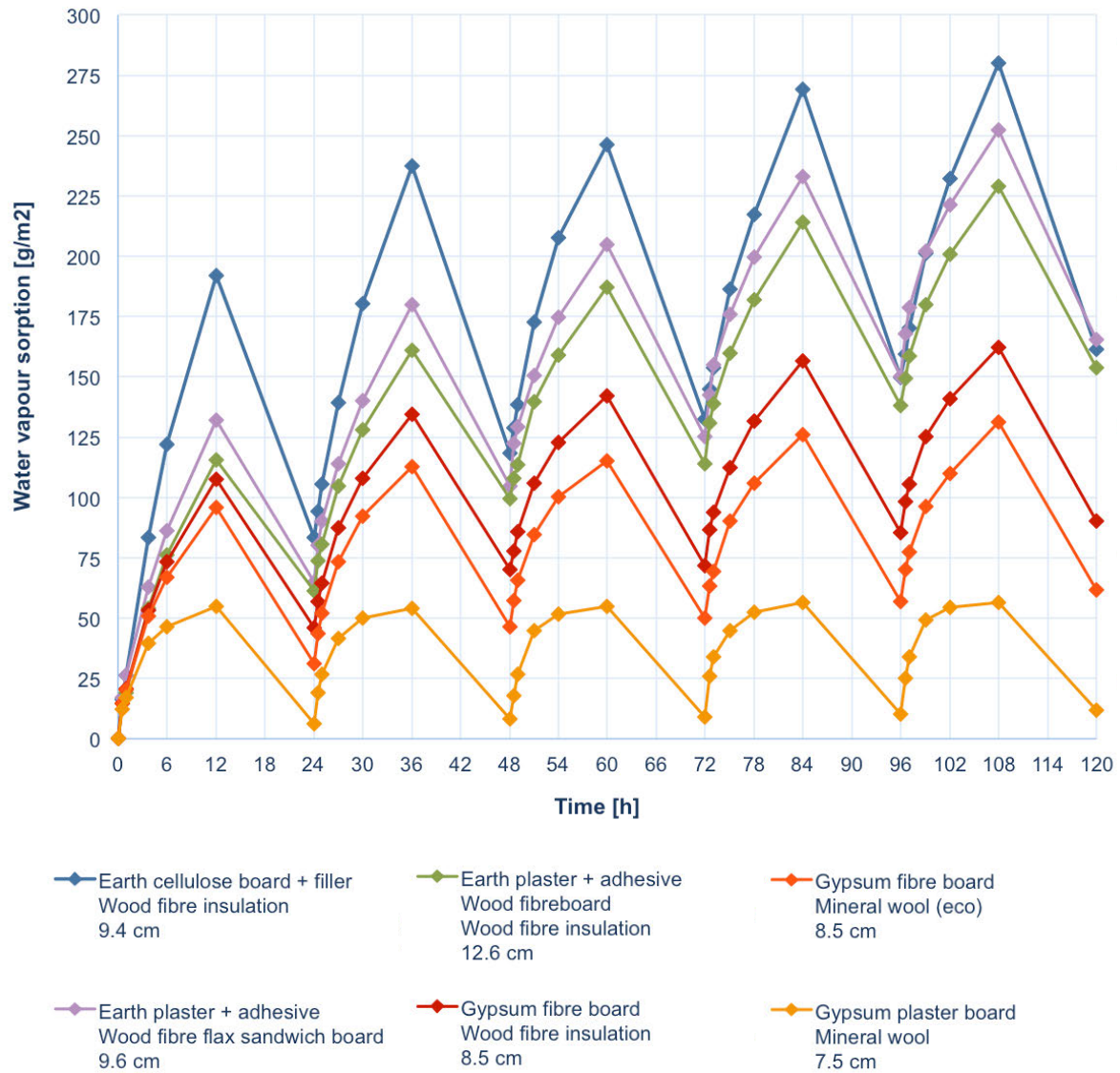

Fig. 3: Results of water vapour sorption test (5 adsorption/desorption cycles) of wall build-ups.

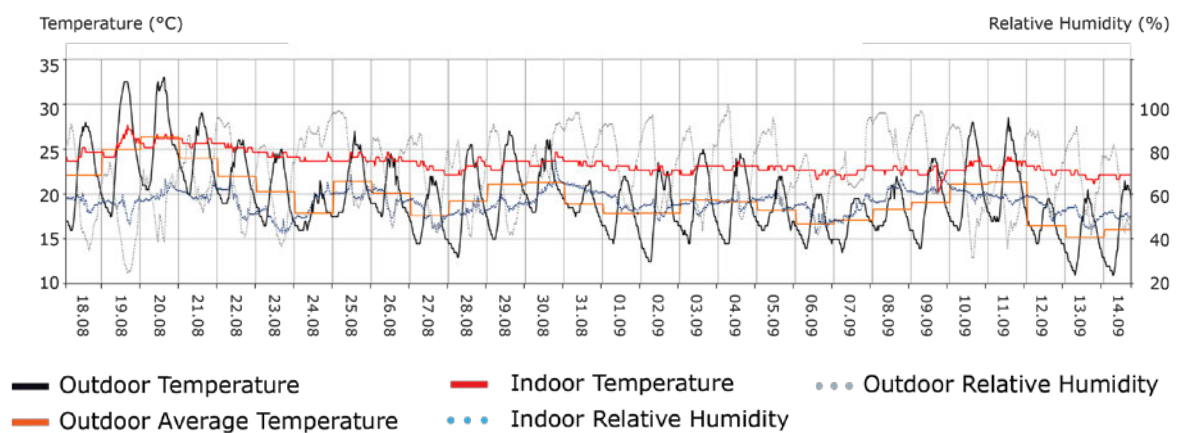

Fig. 4: Monitoring results from a living room of a flat fitted out with earth plasters.

### 3.2 Monitoring

Fig. 4 shows an extract from the monitoring of the results measured in a South facing kitchen room in a flat fitted out with earth plasters and other natural building materials. Relative humidity levels were relatively stable during both periods. Indoor air temperatures were ranging always in comfortable levels, even though outdoor temperatures were above 33 °C. For the other flats, fitted out with conventional building materials relatively low humidity levels indoors during winter and higher indoor air temperatures during summer have been monitored.

### 3.3 Emissions tests

For all tested materials and material combinations low to very low emissions of formaldehyde, VOC and SVOC were determined. Only two of the 19 material combinations did not meet the strict requirements of the AgBB evaluation scheme. The radon exhalation from the earthen materials was low, first of all for earth plasters.

### 3.4 Adsorption of airborne pollutants

The results from adsorption tests demonstrated significantly different results for pure and modified earthen plasters in comparison to wall lining boards specifically designed for the adsorption of airborne pollutants. It could be shown that the addition of aerogels considerably increased the adsorption of the spiked contaminants. The best performance was observed for ND<sub>PI</sub> and CMS<sub>GI</sub> modified plasters similar to the water adsorption behaviour. In general, the polar compounds showed the strongest affinity for all the materials, the non-polar compounds have hardly attached.

## 4 DISCUSSION

### 4.1 Water vapour adsorption tests

Fig. 1 shows the potential of aerogels to increase the moisture adsorption of earthen plasters. While the addition of aerogel type ND<sub>PI</sub> (powder) increased the moisture adsorption only insignificantly, the specimen modified with aerogel type CMS<sub>GI</sub> (granulate) demonstrated a significant increase of moisture adsorption (> 130%) after 12 h in comparison to pure earth plasters. In addition, the adsorption speed of the pure plaster was increased by approx. 100%. The addition of aerogel type CMS<sub>PI</sub> (powder) achieved similar results compared to the specimen modified with aerogel type ND<sub>PI</sub> (powder), although a modified earth base plaster of 5 mm was applied, resulting in a higher plaster thickness in total. The outstanding results of the specimen CMS<sub>GI</sub> enriched with aerogel granulate are most likely related to the structure of the aerogel itself. However, the amount of aerogel granulate that could be integrated into the mixture while meeting the requirements of DIN

18947 [1] is approx. 3 – 5 times higher in comparison to both aerogel powder types, being mainly responsible for the increased moisture adsorption.

The comparison of wall lining boards in Fig. 2 demonstrates the remarkably high moisture adsorption capacity of earthen dry and cellulose boards as well as wood fibre boards in comparison to standard gypsum plaster and gypsum fibre boards. For the earth based boards the clay minerals are mainly responsible for the outstanding adsorption results, whereas for the wood fibre boards it is their high porosity and respectively high surface area. Adsorption capacity of gypsum fibre boards ranges between earth plasters and gypsum plaster boards, offering robust and good solutions, when budget and construction time becoming key factors.

Although this study is not exhaustive, it was observed that congeneric materials achieved very different results, which becomes obvious comparing the results of specimens 3.1.1 and 3.1.2 (Fig. 2). Similar tendencies, but even more distinct were observed for wood fibre and calcium silicate boards.

Material investigations at component level demonstrated the superior performance of natural building materials in comparison to conventional wall build-ups. Fig. 3 demonstrates the impact of earth cellulose boards, pure earthen plasters in combination with wood fibre boards and wood fibre insulation or wood fibre flax sandwich boards in comparison to conventional wall build ups with gypsum plaster boards and mineral wool. The exact benefit on indoor air quality with regards to seasonal changes has to be determined, however it can be assumed that buildings fitted out with such walls, will benefit from evaporative cooling processes during hot summer months.

### 4.2 Monitoring results

Monitoring data shown in Fig. 4 indicates that temperatures in a living area facing South range 6 – 7 °C below outdoor temperatures during hot summer days, which would support the assumption that earth plasters contribute to cooler indoor air temperatures during summer through evaporative cooling.

### 4.3 Emission tests

It is important to note that the AgBB criteria were developed for individual building materials, for the analysis of wall systems a different set of criteria would be more appropriate. The results can therefore only have an orienting character. Nevertheless, it can be established that all other tested natural building materials were uncritical with respect to their emission properties and can be installed in buildings in almost any combination without concern.

#### 4.4 Adsorption of airborne pollutants

The adsorption tests revealed that earth plasters have a good adsorption capacity, which was particularly increased by the addition of aerogel granulate but also by the addition of aerogel powders.

#### 5 CONCLUSION AND OUTLOOK

Results presented in this study suggest that low emitting, natural building materials with enhanced hygroscopic properties such as earth plasters modified by addition of aerogels, wood fibre boards, wood fibre flax sandwich boards and strawboards in combination with natural ventilation offer robust alternatives to mechanical ventilation. Through application of materials able to adsorb airborne pollutants, indoor air quality can be enhanced further. Numerical simulations have started to translate current findings into hygrothermal models for the evaluation of indoor environment quality of residential buildings. The impact of air purifying materials has to be investigated further. The models will be used to predict suitability of materials for specific applications and damage-free constructions.

This research study was made possible with the support of the European Union's 7th Framework Programme for research, technological development and demonstration under grant agreement no. 608893 (H-House, [www.h-house-project.eu](http://www.h-house-project.eu)).

#### 6 REFERENCES

1. DIN 18947: Earth Plasters – Terms and definitions, requirements, test methods, August 2013.
2. Klinge, A. (2013) Natural material with high hygroscopic properties in naturally ventilated buildings, Master thesis, London Metropolitan University.
3. prEN 16516, 2015. Construction products – Assessment of release of dangerous substances – Determination of emissions into indoor air.
4. AgBB, 2015. Health-related evaluation procedure for volatile organic compounds emissions (VVOC, VOC and SVOC) from building products.
5. ISO 16000-part 3, 2011. Indoor air – Determination of formaldehyde and other carbonyl compounds in indoor air and test chamber air – active sampling method.
6. ISO 16000-part 6, 2011. Indoor air – Determination of volatile organic compounds in indoor and test chamber air by active sampling on Tenax TA® sorbent, thermal desorption and gas chromatography using MS or MS-FID.
7. Richter et al., 2013: Determination of radon exhalation from construction materials using VOC emission test chambers. *Indoor Air*, 23:397-405.
8. ISO 16000-part 24, 2009. Indoor air - Performance test for evaluating the reduction of volatile organic compound (except formaldehyde) concentrations by sorptive building materials
9. Minke, G. (2012) Handbook earth construction 8th edition. Staufen bei Freiburg: ökobuch press.
10. Eckerman W. and Ziegert C. (2006) Impact of earthen construction materials on indoor air humidity (October 2006).



## Expanding Boundaries: Systems Thinking for the Built Environment

### ENVIRONMENTAL ASSESSMENT OF RADICAL INNOVATION IN CONCRETE STRUCTURES

S. Zingg<sup>1\*</sup>, G. Habert<sup>2</sup>, T. Lämmlein<sup>3</sup>, P. Lura<sup>4</sup>, E. Denarie<sup>5</sup>, A. Hajiesmaeili<sup>6</sup>

<sup>1,2</sup> Chair of Sustainable Construction, Institute of Construction and Infrastructure Management, Swiss Federal Institute of Technology Zurich (ETH Zurich), 8093 Zurich, Switzerland

<sup>3</sup> Mechanical Systems Engineering Laboratory, Civil and Mechanical Engineering, Swiss Federal Laboratories for Materials Science and Technology (EMPA), 8600 Dübendorf, Switzerland

<sup>4</sup> Concrete / Construction Chemistry Laboratory, Civil and Mechanical Engineering, Swiss Federal Laboratories for Materials Science and Technology (EMPA), 8600 Dübendorf, Switzerland

<sup>5,6</sup> Structural Maintenance and Safety Laboratory, Civil Engineering Institute, Swiss Federal Institute of Technology Lausanne (EPFL), 1015 Lausanne, Switzerland

\*Corresponding author; e-mail: zingg@ibi.baug.ethz.ch

#### Abstract

In the building sector, the contribution of concrete structure to the overall emissions of greenhouse gases is significant. Switzerland is engaged in a 2050 energy strategy where the reduction of the embodied energy of buildings is a key aspect. In this study, we assess the environmental impact of different low energy concrete solutions. The study focuses on technologies that use cement with very high substitution rate (up to 65%) and tensile resistant materials other than steel in order to keep high durability targets. Hybrid wood-concrete structure, low carbon high performance concrete prestressed with carbon fibre reinforced polymer, and ultra-high performance fibre reinforced concrete with synthetic fibre reinforcement are among the studied options. The environmental assessment is done through life cycle analysis using the Ecoinvent database for Switzerland and the SimaPro software. Results of an initial environmental assessment of production of the new technologies, present huge energy and emission savings potential for the energy turnaround.

#### Keywords:

Low energy concrete; hybrid wood-concrete structure; high performance concrete prestressed with carbon fibre reinforced polymer; ultra-high performance concrete with synthetic fibre reinforcement

## 1 INTRODUCTION

After the Fukushima incident in 2011, the Swiss Federal Council has decided to gradually phase-out nuclear energy [1]. Nuclear energy has the biggest share at 37.9% in the Swiss electricity mix and comprises about a quarter of the total energy use in Switzerland in 2014 [2]. To cover the shortfall in energy due to the decision to withdraw from nuclear power, the Swiss Federal Council has redefined its energy policy to ensure long-term energy supply and outlined the "Energy Strategy 2050" [3]. A coordinated research has been set-up through the National Research Program (NRP) 70 and 71 funded by the Swiss

National Science Foundation to support the implementation of the Energy Strategy 2050.

### 1.1 Low energy concrete solutions project

The building sector consumes around 40% of the global energy use [4]. In a building life cycle, the operation phase represents the largest share in the energy consumption; about a quarter is consumed in the production of building materials [4]. Continuous improvements in operation through construction of energy-efficient buildings highlights the increasing contribution from materials. Among the most representative building materials, concrete still dominates in the share of the total embodied energy of buildings [5]. A joint

research project “Concrete Solutions” under NRP 70 has been set up to look into low energy constructive systems to support the overall target of the energy strategy for the Swiss energy turnaround. The project aims to develop *innovative* concrete structures with low energy concrete and reduced steel content. Concrete protects the steel in a structure from corrosion. The substitution of steel, a high energy building material, eliminates the risk of corrosion in a structure and therefore allows further reduction of concrete.

This paper presents the results of the initial environmental assessment of the production of new technologies targeted in the joint research project.

## 2 MATERIALS AND METHODS

The environmental assessment is done through life cycle assessment (LCA) according to the ISO standard [6] using the Ecoinvent 3 database for Switzerland [7] and SimaPro 8.0.5 LCA software [8]. The Ecoinvent database is selected as it is currently the most reliable database for Swiss unit processes.

### 2.1 Impact assessment methods

LCA methods used in this study are harmonized with the methods employed in the KBOB list, a well-established LCA data of buildings and constructions in Switzerland [9]. These methods are: the IPCC 2013 100a method for the calculation of the Global Warming Potential (GWP) or greenhouse gas emissions (also termed as carbon emission in this paper) [10]; the Cumulative Energy Demand (CED) for the calculation of primary energy demand [10]; and the Ecological Scarcity Method 2013 for the calculation of total environmental impacts (UBP) or eco-points [11]. UBP integrates different environmental factors into one indicator. It is an indicator particularly applicable for Switzerland as the method employs eco-factors based on Swiss environmental targets and legislation.

### 2.2 Functional unit and system boundary

Different functional units were used for different assessments. On the material scale, a functional unit of one cubic meter of concrete was used (Section 3.1 and 3.4); on structural scale, one square meter of wood-concrete floor slab (Section 3.2) and one linear meter of prestressed concrete beam (Section 3.3) were used. The functional units were designed on the assumption that the targeted technologies fulfil the same performance and service life as the reference. A cradle-to-gate approach was employed focusing on processes from material up to structural element production.

### 2.3 Data collection

Data of all processes and materials relevant in the development of technological solutions in the joint project were gathered. Processes that are not

available in the Ecoinvent database, e.g. laminated veneer lumber (LVL), carbon fibre reinforced polymer (CFRP) and basalt fibre, were modelled using available data from literature. The modelled data is preliminary. LCA modelling will be improved in parallel with the technological development from the joint project.

### 2.4 Statistical analysis

For the analysis of environmental impact, “*Environmental savings potential (ESP)*” was calculated using percentage relative difference (Equation 1) adapted from Zea Escamilla and Wallbaum (2011) [12]:

$$ESP = \frac{Impact_{ref} - Impact_x}{Impact_{ref}} \times 100 \quad (1)$$

where  $Impact_x$  is the environmental impact (UBP, CED or GWP) of the specific technological solution; and  $Impact_{ref}$  is the environmental impact (UBP, CED or GWP) of the reference.

*Positive* ESP indicates a lesser environmental impact of the technology being assessed compared to the reference; *negative* ESP indicates a higher environmental impact.

## 3 RESULTS AND DISCUSSION

Results of the environmental assessment done at concrete and at structural scale are discussed in this chapter. Three structures are presented: hybrid wood-concrete structure (Section 3.2), low energy high performance concrete prestressed with carbon fibre reinforced polymer structure (Section 3.3), and ultra-high performance fibre reinforced concrete with synthetic fibre reinforcement structure (Section 3.4).

### 3.1 Low energy concrete

Motivation for the development of low energy concrete was underpinned by the introduction of new guidelines from the Swiss Society of Engineers and Architects, the SIA Merkblatt 2049, allowing production of a new generation of Portland cements with clinker substitution level up to 65% [13]. European standard EN 197-1 currently allows up to 35% clinker substitution for Portland composite cements [14].

The study focuses on the optimisation of ternary blend cement with burnt oil shale (BOS) and limestone (CEM II/B-M(T-LL)) which, as of 2015, has the highest share in the total cement supplied in the Swiss market [15]. Compatible *polycarboxylate ether* (PCE) superplasticizers will be developed to address the issues on low strength development at early ages and the uncertainty on long-term properties associated with high clinker substitution.

For the interim assessment, a low energy concrete with 40% clinker content in the cement has been modelled. Polynaphthalene sulfonate (PNS)

plasticizer in the Ecoinvent dataset for concrete was replaced with PCE superplasticizer modelled from Häner, et al (2005) [16]. Due to an unavailability of BOS data in Ecoinvent, whose impact allocation was assumed as negligible based on the available LCA of oil shale industry [17], a binary cement with limestone was used in the model.

The production of the modelled low energy concrete presents more than 40% savings on primary energy and around 50% savings on emission compared to the reference concrete with ordinary Portland cement (OPC / CEM I). Savings on concrete come almost entirely from low clinker cement. The substitution of clinker with limestone presents a reduction directly proportional to the substitution rate because limestone, a locally available resource in Switzerland, has almost a negligible environmental burden compared to clinker.

It is noted however that a higher clinker substitution does not necessarily mean better savings as presented in the study of Pushkar and Verbitsky (2016) [18]. The choice of supplementary cementitious material (SCM) is critical to optimizing the concrete mix. Depending on the environmental burden allocation of secondary material used as SCM, e.g. fly ash, slag or BOS, the resulting concrete mix could have a lower or a higher environmental impact [18]. LCA modelling of low energy concrete will be improved to consider the allocation impact from secondary material particularly BOS, in parallel with the optimization of concrete.

### 3.2 Hybrid wood concrete structure

One of the innovative concrete structures to be developed in the project is the hybrid wood-concrete structure without steel. This is a targeted improvement to the wood-concrete technology used in the construction of ETH House of Natural Resources (HoNR), a two-storey building located in ETH Zurich Campus. HoNR is an innovation in timber construction, where laminated veneer lumber (LVL) was used as formwork and reinforcement to substitute steel [19]. To comply with fire safety standards, steel was not totally replaced [20]. A connection system without steel fasteners will be developed by looking into material lay-up and potential glue that could effectively bind wood and concrete. The research will also look into LVL with improved fire retardancy to totally eliminate dependency on steel. Low energy concrete will be used to optimize the wood-concrete structure.

Figure 1 presents the results of the environmental assessment of the floor slab structure using the targeted low energy wood-concrete solution of the project (*wood concrete optima*) relative to the reference conventional reinforced concrete and compared to wood-concrete technology used in HoNR (*wood concrete HoNR*). Design

specifications are presented in Table 1. The production of *wood concrete optima* presents around 50% potential savings in energy and 70% in emission compared to the conventional reinforced concrete due to an improvement in concrete and a total elimination of steel. A total elimination of steel however is an optimistic assumption. The task of the research is to look into the right balance of steel substitution that would ensure structure durability and fire safety.

	Conventional reinforced concrete <sup>a</sup>	Wood concrete HoNR <sup>b</sup>	Wood concrete optima <sup>c</sup>
Cement per cubic meter, kg/m <sup>3</sup>	300	375	375
Concrete thickness, mm	280	160	160
LVL thickness, mm	0	40	40
Steel fraction, %	1.12	1.07	0

<sup>a, b</sup> Modelled from actual application of wood-concrete technology (using CEM I) in HoNR floor slabs [21].

<sup>c</sup> *Wood concrete optima* is modelled using cement with 40% clinker and no steel.

Table 1: Design of one square meter wood-concrete floor slab. Based on Tai Ly (2014) [21].

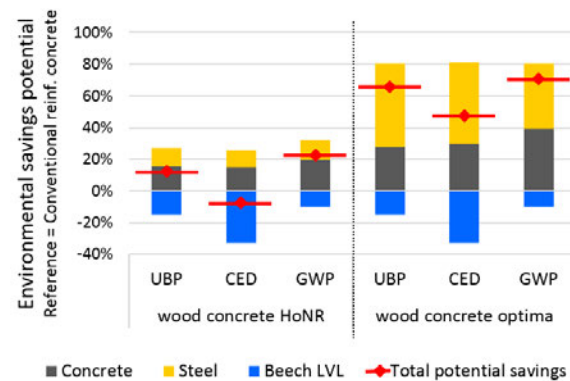

Fig. 1: Environmental impact assessment of 1 m<sup>2</sup> of wood concrete floor slab structure. Reference is conventional reinforced concrete. Design is based on Table 1.

LVL in this study is modelled from *beech* wood, which is a locally available resource in Switzerland and the production process is modelled based on Zimmer and Kairi (2011) [22]. The environmental assessment done on beech LVL shows that more than 50% of the embodied energy comes from adhesives. Phenolic resin is the adhesive used based on the production process of Pollmeier, the LVL supplier in Germany [23]. Phenolic resin has a higher environmental impact than other adhesives like melamine urea formaldehyde (MUF) and polyurethane (PUR), but is attractive because of its high strength and high adhesion to wood [24]. It has also a lesser impact on health compared to MUF as less formaldehyde is released [24]. One limitation of the phenolic resin data in Ecoinvent, as noted by Messmer (2015), is that it is not based on a real production situation but rather on rough estimates [24]. The beech LVL

model will be improved to consider primary data from industry.

### 3.3 Low energy high performance concrete prestressed with carbon fibre reinforced polymer

Another concrete structure targeted in the project is the low energy high performance concrete (HPC) using carbon fibre reinforced polymer (CFRP) as pre-stressing. Special prestressed structural elements with lightweight and durable properties are targeted by replacing steel with CFRP, a strong and more corrosive-resistant material [25]. Although CFRP is more energy intensive than steel [26], the benefit from the substitution is the reduction of volume of concrete in the structural design. A concrete cover is needed to protect the structure from corrosion due to steel.

One linear meter of beam with design parameters presented in *Table 2* is the functional unit used for the environmental assessment of the HPC beam prestressed with CFRP (HPC-CFRP) compared to the conventional reinforced concrete beam and HPC beam prestressed with steel (HPC-steel).

	Conventional reinforced concrete <sup>a</sup>	HPC-steel <sup>b</sup>	HPC-CFRP <sup>c</sup>
Tensile load, kN	270	270	270
Concrete strength, MPa	30	90	90
Cross-section, cm <sup>2</sup>	900	429 <sup>d</sup>	189
Volume, m <sup>3</sup>	0.09	0.043	0.019

<sup>a</sup> 1.12% vol. steel; <sup>b</sup> 0.85% vol. steel; <sup>c</sup> 0.84% vol. CFRP

<sup>d</sup> Additional concrete cover for steel protection is included.

*Table 2: Design of one linear meter beam structure. Based on e-mail communication with T. Lämmlein (EMPA) dated 04.03.2016.*

The environmental assessment of HPC-CFRP presented in *Figure 2* gives a savings potential in energy of around 60% and 70% in emission relative to the reference conventional reinforced concrete. This huge savings potential is consequent to almost a fivefold reduction in volume of the beam (*Table 2*). Analysis relative to HPC-steel, which is more reasonable in terms of lightweight and durable applications, presents around 10% savings in energy and more than 20% in emission (*Figure 2*). Note that further optimization of HPC-CFRP using cement with 40% clinker instead of OPC (see *HPC-CFRP optima* in *Figure 2*) presents an additional 5% to 8% environmental savings potential.

LCA of CFRP shows a high impact contribution from carbon fibre. The life cycle inventory of CFRP is not readily available in the Ecoinvent database. Processes were modelled from Griffing and Overcash (2010) [27] for the carbon fibre production, Suzuki and Takahashi (2005) [28] for the Pultrusion process, and Terrasi (2008) [29] for the carbon fibre and epoxy mix. The high embodied energy of carbon fibre is due to the

carbon fibre production, specifically the production of a precursor [30], which is a good target for energy optimization. According to Suzuki and Takahashi (2005), the production scale of carbon fibre is not yet high enough to result in high efficiency as the industry is relatively young [28]. Efficiency in the carbon fibre production is largely dependent on technology and facility [26].

A further reduction of the environmental impact of HPC-CFRP is expected during the construction phase. Savings from structural designs due to a potential reduction in concrete volume for foundations and columns, as well as from transportation and machine usage due to lightweight and durable HPC-CFRP elements, will be assessed. The issue on carbon fibre recyclability will also be looked at in the next steps of this study.

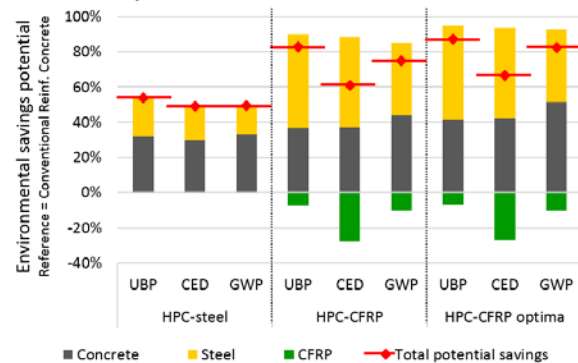

*Fig. 2: Environmental impact assessment of 1 linear meter HPC-CFRP beam structure. Reference is conventional reinforced concrete. HPC and reference are modelled using OPC while HPC optima is modelled using cement with 40% clinker. Beam design is based on *Table 2*.*

### 3.4 Ultra-high performance fibre reinforced concrete with synthetic fibre reinforcement

The replacement of steel reinforcements with synthetic fibres for ultra-high performance fibre reinforced concrete (UHPFRC) is another low energy concrete structure to be developed in the project. UHPFRC has a very high durability compared to conventional concrete due to its extremely low permeability and is attractive to use for applications such as bridge construction and rehabilitation [31]. Two potential synthetic fibres are targeted in the project – polyethylene (PE) and basalt. The use of basalt fibre in construction is gaining attention in research due to its promising mechanical properties [32]. PE fibre is also considered due to its high tensile strength, relatively high modulus of elasticity, and much lower density compared to steel [33]. Dataset for basalt fibre production is not readily available in Ecoinvent and is modelled from production data provided by De Fazio (2011) [34].



	Conventional UHPFRC	UHPFRC with PE	UHPFRC with basalt
<i>in kg</i>			
Cement	650	657	657
Limestone filler	559	565	565
Silica fume	137	138	138
Quartz sand	573.5	580	580
Water	180	182	182
Superplasticizer	42.5	42.8	42.8
Steel fibre	314	0	0
PE fibre	0	19.6	0
Basalt fibre	0	0	54

*Table 3. Preliminary mixes of 1 m<sup>3</sup> UHPFRC with different fibre reinforcements. Based on email communication with E. Denarie and A. Hajiesmaeili (EPFL) dated 01.12.2015.*

Interim mix designs for the environmental assessment of one cubic meter of UHPFRC with different fibre reinforcements are presented in Table 3. The environmental assessment of mixes with synthetic fibres and low clinker cement presents more than a 50% environmental savings potential compared to conventional UHPFRC as shown in Figure 3, mainly because of the substitution of steel with PE and basalt fibres.

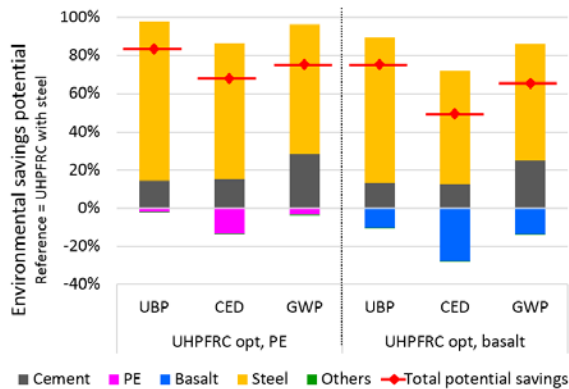

*Figure 3: Environmental assessment of 1 m<sup>3</sup> of UHPFRC with synthetic fibre substitutes. Reference is conventional UHPFRC with steel and OPC. UHPFRC with PE and basalt are modelled using cement with 40% clinker. Design is based on Table 3.*

This study is focused on the environmental assessment of UHPFRC on the material level to see the substitution potential from selected synthetic fibres. Next steps will look into the structural level and will consider the whole life cycle analysis to assess also savings from maintenance. According to Habert, et al (2013), the use of UHPFRC could provide a considerable impact reduction within the whole life cycle compared to conventional concrete solutions due to savings from service life maintenance [31].

#### 4 CONCLUSIONS

The initial environmental assessment of production of the targeted technologies in the

project presents a huge energy and emission savings potential for the energy turnaround. Low energy concrete could reduce energy by more than 40% and cut carbon emission by half compared to conventional concrete. Interim analysis done on structural elements using low energy concrete and a substitution of steel with other tensile-resistant materials gives promising results in terms of the energy and emission savings potential, as well as eco-points.

The next step of this study is the assessment on a structural level from cradle-to-grave, including savings from structural design, transportation and end-of-life. LCA modelling will be improved in parallel with the development of low energy concrete technologies in the project.

#### 5 ACKNOWLEDGMENTS

The authors would like to thank Swiss National Science Foundation for funding "Concrete Solutions Joint Research Project" under NRP 70 Energy Turnaround. We acknowledge the whole team working in the joint research project from EMPA, EPFL and ETHZ for their respective works developing the technological solutions where this environmental assessment is anchored on.

#### 6 REFERENCES

- Kirchner, A., D. Bredow, F. Ess, T. Grebel, P. Hofer, A. Kemmler, and J. Struwe. 2012. "Die Energieperspektiven für die Schweiz bis 2050." Bern Bundesamt für Energie (BFE), Switzerland.
- Federal Statistical Office FSO. 2016. *Statistical Data on Switzerland 2016*. Neuchatel, CH: Federal Statistical Office. ISBN 978-3-303-00544-6.
- Steinmann, W. 2012. "Energiestrategie 2050: Konzept, Stand und nächste Schritte." Bern Bundesamt für Energie (BFE), Switzerland.
- UNEP Sustainable Buildings and Climate Initiative. 2014. *Greening the Building Supply Chain*. DTI/1753/PA.
- Solis-Guzman, J., and M. Marrero. 2015. "Chapter 6 Case Study." In *Ecological Footprint Assessment of Building Construction*. Sharjah, UAE: Bentham Science Publishers. 111-144. 978-1-68108-099-4.
- ISO. 2006. "ISO 14040: Environmental management—life cycle assessment—principles and framework." London: British Standards Institution.
- Weidema, B., C. Bauer, R. Hischer, C. Mutel, T. Nemecek, J. Reinhard, C. Vadenbo, and G. Wernet. 2013. "Overview and methodology. Data quality guideline for the ecoinvent database version 3." *Ecoinvent Report*. St. Gallen, CH: Swiss Centre for Life Cycle Inventories. <http://www.ecoinvent.org>

8. Goedkoop, M., M. Oele, M. Vieira, J. Leijting, T. Ponsioen, and E. Meijer. 2014. "SimaPro Tutorial." Netherlands: Pré Consultants.
9. KBOB, eco-bau and IPB. *Liste Ökobilanzdaten im Baubereich* 2009/1:2014. KBOB c/o BBL Bundesamt für Bauten und Logistik. Retrieved from <https://www.kbob.admin.ch/kbob/de/home/publikationen/nachhaltiges-bauen.html>
10. Frischknecht, R., N. Jungbluth, H. Althaus, C. Bauer, G. Doka, R. Dones, R. Hischier, S. Hellweg, S. Humbert, and T. Köllner. 2007. "Implementation of life cycle impact assessment methods." *Ecoinvent report*. St. Gallen, CH: Swiss Centre for Life Cycle Inventories.
11. Frischknecht, R., and S. Büsler Knöpfel. 2013. "Swiss eco-factors 2013 according to the ecological scarcity method." Federal Office for the Environment FOEN. [www.bafu.admin.ch/ue-1330-e](http://www.bafu.admin.ch/ue-1330-e)
12. Zea Escamilla, E., and H. Wallbaum. 2011. "Environmental savings from the use of vegetable fibres as concrete reinforcement." 6th International Structural Engineering and Construction Conference. Zürich, Switzerland.
13. SIA. 2014. "Merkblatt 2049: Anforderungen an neue Zemente." Zürich: Schweizerischer Ingenieur u. Architektenverein.
14. EN. 2000. "197-1 (2000) Cement: composition, specifications and conformity criteria for common cements." London British Standards Institution.
15. Cemsuisse. 2015. "Zementlieferungen 4.Quartal 2015."
16. Häner, A., M. Schluemp, and R. Gälli. 2005. "Mass flow and risk analysis of modern superplasticizers." ORGAGEC Symposium.
17. Gavrilova, O., T. Randla, L. Vallner, M. Strandberg, and R. Vilu. 2005. "Life cycle analysis of the Estonian oil shale industry." Tallinn, Estonia: Tallina University of Technology.
18. Pushkar, S., and O. Verbitsky. 2016. "Effects of different allocation approaches for modeling mineral additives in blended cements on environmental damage from five concrete mixtures in Israel." *Materials and Structures*, 1-15.
19. Wanninger, F., A. Frangi, and M. Fragiocomo. 2014. "Long-Term Behavior of Posttensioned Timber Connections." *Journal of Structural Engineering* 141 (6): 04014155-1 to 13.
20. Leyder, C., F. Wanninger, A. Frangi, and E. Chatzi. 2015. "Dynamic response of an innovative hybrid structure in hardwood." *Construction Materials* 168 (CM3): 132-143.
21. Ly, T. 2014. "Life cycle assessment of wood concrete composite floor." Master Thesis. Institute of Construction and Infrastructure Management, ETH Zürich.
22. Zimmer, B., and M. Kairi. "LCA of Laminated Veneer Lumber - Finnforest Study."
23. Pollmeier. "BauBuche FAQs." <https://www.pollmeier.com/en/products/baubuche/technical-aspects.html>. Accessed 21.04.2016.
24. Messmer, A., and S. Hellweg. 2015. "Life cycle assessment (LCA) of adhesives used in wood constructions." Master Thesis. Institute of Ecological System Design-ETH Zürich. Zürich, Switzerland: Swiss Federal Institute of Technology Zurich.
25. Fitzer, E., A. Foley, W. Frohs, T. Hauke, M. Heine, H. Jäger, and S. Sitter. "Fibres, 15. Carbon Fibres." In *Ullmann's Encyclopedia of Industrial Chemistry*. ISBN 3527306730.
26. Griffing, E., E. Vozzola, and M. Overcash. 2014. "Life cycle inventory data for carbon fibre and epoxy systems and use in environmentally optimized designs." LCA XIV San Francisco.
27. Griffing, E., and M. Overcash. 2010. "Carbon fibre HS from PAN. Chemical Life Cycle Database." [www.environmentalclarity.com](http://www.environmentalclarity.com)
28. Suzuki, T., and J. Takahashi. 2005. "Prediction of energy intensity of carbon fibre reinforced plastics for mass-produced passenger cars." Ninth Japan International SAMPE Symposium JISSE-9, Tokyo, Japan.
29. Terrasi, G., C. Affolter, M. Barbezat, and G. Bättig. 2008. "Increasing the acceptance of high performance concrete prestressed with CFRP." Proceeding of the Fourth International Conference on FRP Composites in Civil Engineering (CICE2008).
30. US Department of Energy. 2015. "Chapter 6: Innovating Clean Energy Technologies in Advanced Manufacturing." In *Quadrennial Technology Review 2015. An Assessment of Energy Technologies and Research Opportunities*. <http://energy.gov/quadrennial-technology-review-2015>
31. Habert, G., E. Denarié, A. Šajna, and P. Rossi. 2013. "Lowering the global warming impact of bridge rehabilitations by using Ultra High Performance Fibre Reinforced Concretes." *Cement and Concrete Composites* 38 1-11.
32. Fiore, V., T. Scalici, G. Di Bella, and A. Valenza. 2015. "A review on basalt fibre and its composites." *Composites Part B: Engineering* 74 74-94.
33. Zheng, Z., and D. Feldman. 1995. "Synthetic fibre-reinforced concrete." *Progress in Polymer Science* 20 (2): 185-210.
34. De Fazio, P. 2011. "Basalt fibre: From earth an ancient material for innovative and modern application." *Energia, Ambientee Innovazione* 3 89-96.



## Expanding Boundaries: Systems Thinking for the Built Environment

### NANOTECHNOLOGY AND ITS IMPACT ON SUSTAINABLE ARCHITECTURE

N. Eisazadeh<sup>1\*</sup>, K. Allacker<sup>2</sup>

<sup>1</sup> Faculty of Engineering Science, Department of Architecture, Kasteelpark Arenberg, box 2431, 3001 Leuven

<sup>2</sup> Faculty of Engineering Science, Department of Architecture, Kasteelpark Arenberg, box 2431, 3001 Leuven

\*Corresponding author; e-mail: nazanin.eisazadeh@student.kuleuven.be

#### Abstract

Diminishing natural resources, increasing levels of carbon emissions from the transformation of raw materials into products, and the growing demand for consumable materials are factors that raise the question "how can a balance between the need for development and the protection of natural resources be created"? As a large share of the energy consumption is related to buildings, analysing the role of advanced materials in architecture and its contribution to sustainability is essential. This paper discusses nanotechnology's promise of lower energy and raw material consumption, reduced waste, greater safety and a healthier environment in the context of sustainable architecture.

Nanotechnology is an expanding and innovating area of research and in architecture, it will greatly impact construction materials since the fundamental properties of materials like surface-to-mass ratio, elasticity, conductivity and strength can be controlled at nano-scale. Products like high-insulating panels, self-cleaning and heat-absorbing windows will influence the building industry as such materials have the potential to improve the energy efficiency, durability, economy and sustainability of the built environment.

Nano insulating coatings are more efficient than traditional insulators and have a lesser environmental impact. As they can be used for the renovation of existing buildings, they increase the potential of reuse without the aesthetic and functional compromises often required by thick layers of insulation.

This paper investigates the application areas of nanomaterials in the construction industry, illustrated with case studies. Investigating the opportunities and challenges provides the basis for the successful implementation and development of these materials.

#### Keywords:

Sustainability; Nanotechnology; Nanomaterials; Energy efficiency

### 1 INTRODUCTION

The building and construction industry are an important consumer of energy resources and materials. The current demand for more sustainable practices has imposed a tremendous pressure on this field to develop and utilize new environmentally friendly materials [1] [2].

The definition given by the German Federal Ministry of Education and Research summarises nanotechnology as "Nanotechnology refers to the creation, investigation and application of structures, molecular materials, internal interfaces

or surfaces with at least one critical dimension or with manufacturing tolerances of less than 100 nanometres" [4].

Nanotechnology provides the possibility to create new materials with unique and enhanced properties that can respond to specific functions or implementing qualities and performances in existing materials [5][6].

Nanotechnologies contribution to construction industry:

- Reduction in the consumption of raw materials, energy and CO<sub>2</sub> emissions
- Enhancing the properties of existing products
- Reduction in weight and/or volume
- Reduction in the number of production stages [4]

Nanomaterials are perceived by some as potential health hazards but by most as a way of reducing them. Environmental concerns and sustainability issues range from embodied energy used for production all the way through to recycling. Moreover, economic concerns, including both initial and long-term costs are present. On the other hand, nanomaterials could greatly extend the durability and lifespan of materials, thus reducing maintenance and replacement costs and improving energy efficiency [3] [4] [7].

## 2 NANOSTRUCTURED MATERIALS

Nanomaterials are materials with at least one dimension below 100 nm ( $1 \text{ nm} = 1 \times 10^{-9} \text{ m}$ ) (fig. 1). A nanostructured material can be defined as a traditional material (steel, concrete, glass...) blended in mass or surface with nanomaterials or correcting and improving the chemical and physical structure of materials at nanoscale (production process does not require the use of nanomaterials) [5].

In both cases, the original characteristics of the materials are modified and optimized in order to obtain specific performances, usually not comparable to those shown by the original materials. Therefore, enabling to produce a high variety of materials with different functions [5][6].

## 3 NANOMATERIALS IN CONSTRUCTION

The potential of nanotechnology in construction as pointed out in RILEM TC 197-NCM report:

- Increasing the strength and durability of concrete
- Production of cheap corrosion-free steel
- Production of very effective thermal insulators
- Production of multifunctional coatings and thin films [8]

Table 1 shows nanomaterials being utilized in the construction industry.

### 3.1 Concrete

Concrete is the most widely used manufactured construction material. Energy use, carbon emissions and waste are all major environmental concerns connected with concrete production and use. Therefore, finding ways to overcome durability issues, is a crucial step in concrete sustainability [3] [7] [8].

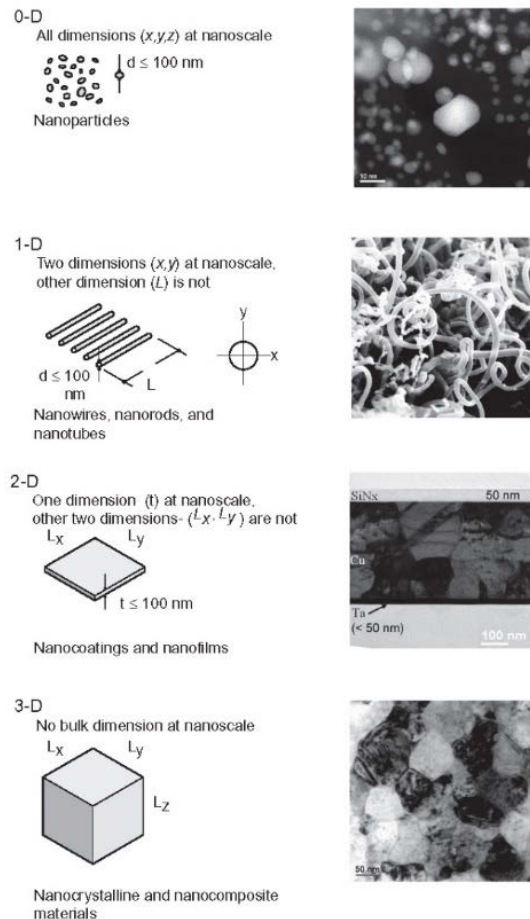

Fig. 1: Classification of nanomaterials [7].

Manufactured nanomaterials	Architectural/Construction materials	Expected benefits
Carbon nanotubes	Concrete Ceramics	Mechanical durability, Crack prevention Enhanced mechanical and thermal properties
SiO <sub>2</sub> nanoparticles	Concrete Ceramics Window	Reinforcement in mechanical strength Light transmission, Fire resistant Anti-reflection, Flame retardant
TiO <sub>2</sub> nanoparticles	Cement Window Coating/Paint	Self-cleaning, Rapid hydration Super hydrophilicity, Anti-fogging Self-cleaning, Antimicrobial properties
Fe <sub>2</sub> O <sub>3</sub> nanoparticles	Concrete	Abrasion-resistant, Increased strength
Cu nanoparticles	Steel	Weldability, Corrosion resistance
Ag nanoparticles	Coating/Paint	Antimicrobial properties

Table 1: Example of nanomaterials in construction [1].

Nanosilica improves the hydration process of cement due to their large reactive surface area, increase the viscosity of the fluid phase of concrete, improve bonds between pastes and aggregates, fill the voids between cement grains and finally reduce calcium leaching in water. All factors that lead to enhancement in strength, flexibility, durability and workability of concrete [2] [3] [7].

Addition of Titanium dioxide ( $\text{TiO}_2$ ) nanoparticles increases the rate as well as the peak of the hydration process. Self-cleaning concrete is produced by utilizing the photocatalytic and hydrophilic (water-attracting) properties of  $\text{TiO}_2$  (fig. 2) [3] [7] [8] [9].



Fig. 2: Church Dives in Misericordia, Rome, Italy (Product: Self-cleaning concrete) [4].

### 3.2 Steel

Steel is a major component in reinforced concrete construction as well as a primary construction material. Nanotechnology improves the corrosion resistance of steel. MMFX Steel (brand) is manufactured using nanoscale processes. The steel produced has a unique laminated structure (plywood effect) that makes it very strong and corrosion resistant [3].

Nanocoatings can help protect stainless steel surfaces against corrosion and metal oxide staining. The addition of magnesium and calcium nanoparticles reduces the size of heat affected

zone (HAZ); as a result, weld toughness is increased and less material is used to keep stresses within allowable limits [3].

### 3.3 Wood

Wood is a renewable building material that can be recycled and regenerated. Low conductivity of wooden structures reduces the heating and cooling loads. Additionally, wood has the ability to reduce carbon emissions by converting  $\text{CO}_2$  into oxygen. However, wood must be protected from water, pests, mold and UV radiation [3].

Nanotechnology has the potential to improve the performance and functionality of wood-based products; for example, nanosensors can identify mould, decay, and termites, nanocoatings can make self-cleaning wood surfaces [3].

Hydrophobic nanocoatings protect the wood against weathering and slow down the discoloration process. Nanoscale UV absorbers added to coatings reduce the degrading effects of UV radiation. Nanotechnology is expected to produce the next generation of bio-products that have higher performances and longer lifespans by giving scientists control over bonding at the nanoscale [3][4].

### 3.4 Thermal Insulation

Thermal insulation has a great impact on saving energy and reducing emissions by decreasing the amount of energy required to sustain a comfortable environment in buildings. Nanotechnology promises to provide more efficient building insulation (fig. 3) [3] [4].

#### 3.4.1 Aerogel

Aerogel or “frozen or solid smoke” is a well-known nanoscale material with high insulating properties (fig. 4) and less thickness compared to traditional materials. Aerogel is a light foam like structure that contains more than 95% air and less than 5% silica nanoparticles and has the lowest thermal conductivity and weight of any solid [3][4][5][7].

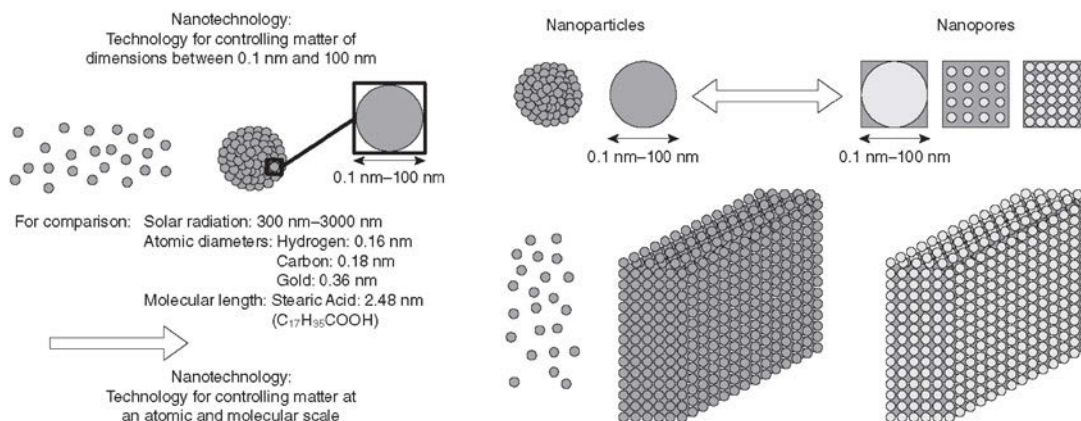

Fig. 3: Nanotechnology application in thermal insulation [10].

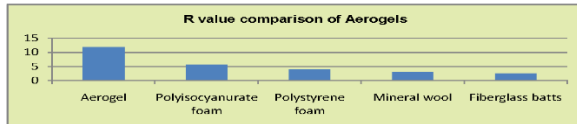

Fig. 4: R value comparison of aerogel [2].

Aerogel particles are used as high performance insulation additives in composite insulation boards and plasters, as well as stand-alone blown-in or poured-in insulation for cavity fill applications. Aerogel-filled panels are translucent, exhibit good light transmission and spread a glare-free soft light, obviating the need for shading systems and artificial lighting during the day as seen in figure 5. Aerogel, also acts as a sound insulator which makes aerogel panels suitable not only for facades but also for interiors, for example around conference rooms [3] [4] [7] [11].

#### 3.4.2. Insulating coatings

Nanocoatings improve the insulating values of conventional materials due to the fact that they can be applied directly to external surfaces in the form of spray or paint. These coatings provide an insulation function by trapping air at the molecular level [3] [7].

#### 3.4.3. Vacuum insulation panels (VIPs)

Vacuum insulation panels (VIPs) provide good thermal insulation whilst consuming less space. New thinner VIPs use aerogel or fumed silica within a vacuum and have up to 10 times smaller thermal conductivity than conventional insulation panels. The thin construction and high insulating performance of VIPs make them suitable for renovation [4] [7] [11].



Fig. 5: Sports hall, Carquefou, France (Product: Multi-wall panels with nanogel filling) [4].

VIPs are recyclable after their useful life. A problematic issue concerning VIPs is the degradation of thermal resistance (aging) initiated by penetration of gases (especially water vapor) into the seal. Many factors contribute to this problem, including relative humidity, the type of building envelope, the amount of vacuum and the correct installation of the product [4] [7].

#### 3.4.4. Latent heat storage (PCM)

Latent heat storage, also known as phase change material (PCM), can be used for temperature regulation. The thermal retention of PCM can be

used for levelling out temperature fluctuations and reducing peak temperatures. In addition to conserving energy by reducing the energy demand for heating and cooling, PCMs are also recyclable and biologically degradable [4].

PCMs are commonly made from paraffin and salt hydrates. Small paraffin balls with a diameter of between 2 and 20 nm are enclosed in a sealed plastic layer and integrated into typical building materials (around 3 million in 1 cm<sup>2</sup>) [4].

PCM is able to retain heat and use it to liquefy the paraffin allowing the indoor environment to remain cooler for longer. The same principle also functions in the other direction; during a phase change PCMs are able to store heat as well as cold. PCMs can be integrated into conventional building materials such as plasters, gypsum board and concrete [2] [4].

### 3.5 Nanocoatings

Nanocoatings have the greatest market potential for any nano-based product. Nanomaterials are quite expensive, but nanocoatings use small quantities of nanoparticles and exhibit many of the properties with minimal production cost. Additionally, the coatings are quite thin and cover large areas [7].

Nanocoatings are produced by nanoparticles bonded to conventional materials or directly integrated into the base material. The aim is to improve the characteristics and add new functional properties. Surfaces treated with nanocoatings exhibit multifunctional properties such as self-cleaning, antimicrobial, antifogging, UV protection, scratch-resistant, corrosion-resistant, air-purification, solar protection, etc. [3] [4] [7].



Fig. 6: Sonnenschiff Centre, Freiburg, Germany (Product: Vacuum insulation panel and PCM) [4].

#### 3.5.1. Self-cleaning nanocoatings

Self-cleaning can be achieved in several ways based on hydrophobic (water-repellent), hydrophilic (water-attracting) or photocatalytic properties; these approaches can be combined in a variety of ways [4].

### Lotus effect

Lotus leaves (fig. 7) exhibit a microscopically rough water-repellent (hydrophobic) surface. Due to this structure water forms tiny beads and rolls off taking dirt with it [3] [4] [7] [8].

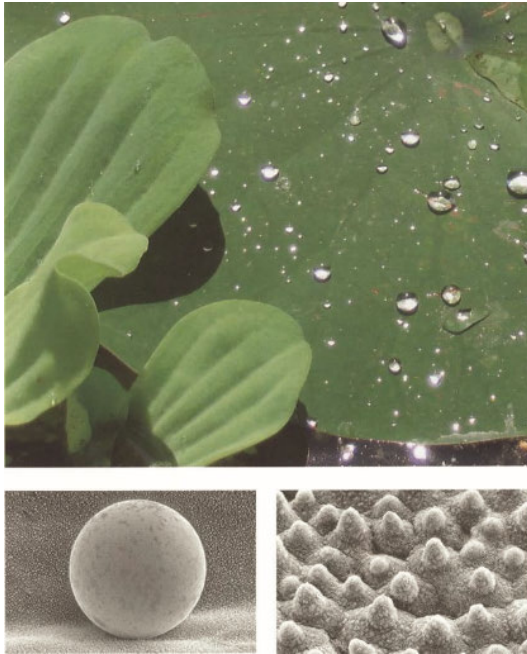

Fig. 7: The surface is covered with nanostructured 5-10 micrometer high knobbles with waxy tips [4].

Artificial lotus effect is produced by nanosurfaces with roughness characteristics that serve the hydrophobic function. Lotus effect is used in Ara Pacis Museum in Rome to retain the whiteness of travertine as shown in figure 8. Hydrophobic coatings can be used in wood, metal, masonry, concrete, leather and textiles. Hydrophilic self-cleaning involves extremely smooth surfaces with low surface energy; forming a thin film of water that aids in cleaning [4][7].

Photocatalytic self-cleaning is a natural process that happens when certain nanomaterials are subjected to ultraviolet (UV) light. The absorbed UV ray initiates the catalytic reaction that oxidizes and decomposes foreign particles so that the loosened particles can be washed away. Since  $\text{TiO}_2$  and  $\text{ZnO}$  are economical and respond well to UV light they are usually used. In self-cleaning glasses, thin  $\text{TiO}_2$  coatings exhibit photocatalytic and hydrophilic properties as shown in figures 9 and 10 [3][7].

Another advantage of this process is reduction in the lighting cost due to the fact that daylight is less obscured by surface dirt. In addition to self-cleaning, the surfaces also exhibit antimicrobial, antifogging and air-purification properties. So any advances in this field not only saves energy and labour costs, but could also aid reduce hazardous substances and be beneficial for the environment [4][7].



Fig. 8: Ara Pacis Museum, self-cleaning nanocoating (Lotusan) is invisibly integrated into the surface [4] (<http://quotesgram.com/richard-meier-quotes>).

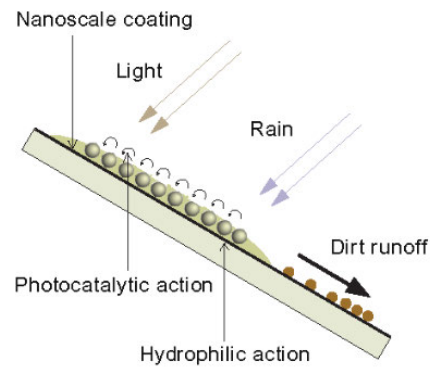

Fig. 9: Thin titanium dioxide coating [7].

### 3.5.2. Antimicrobial coatings

Bacteria and fungi production on surfaces is one of the main factors responsible for materials degradation and the health problems experienced by building occupants. Several approaches are available to create surfaces with antibacterial or antimicrobial properties using nanomaterials. One method is to use nanocoatings embedded with copper or silver nanoparticles. Another way is to integrate nanoparticles directly on the surface of the base material. Both procedures are already being used in floor coverings, panels and paints [4] [7] [8].

Photocatalytic action can also be used to achieve antibacterial or antimicrobial surfaces and since this process depends on UV light it can be applied to products exposed to natural or artificial UV light (fig. 11). One of the architectural applications of this method is in large tents and other types of membrane structures to prevent discoloration or staining caused by bacteria growth [7] [8].

### 3.5.3. Anti-fogging nanocoatings

The main aim of creating fog-free clear appearance is preventing the formation of water droplets and creating a thin transparent film. This can be achieved by nanocoatings with hydrophilic properties [4].



Fig. 10: G-Flat, Tokyo, photocatalytic self-cleaning glass coating (Product: Sagan Coat) [4].



Fig. 11: Operating theatre, Berlin, Germany (Product: "Hydrotec" tiles, photocatalytic surface with antibacterial effect) [4].

#### 3.5.4. Nanopaints

The addition of  $\text{TiO}_2$  and  $\text{SiO}_2$  nanoparticles adds scratch resistance, self-cleaning, glossiness, air-purifying, antimicrobial and fire resistance properties to paint [7] [12].

#### 3.6 Solar Radiation

Glass plays a major role in the energy performance of buildings by controlling daylight and solar heat gain. Studies show nanotechnology has four approaches regarding solar radiation:

- (i) Nanocoatings: spectrally sensitive coatings filter out unwanted infrared frequencies and reduce heat gain
- (ii) Thermochromic technologies: provide thermal insulation (heat protection) whilst maintaining adequate lighting (light transmission adapts to temperature)
- (iii) Photochromic technologies: reacting to changes in light intensity by increasing absorption
- (iv) Electrochromic technologies: reacting to changes in applied voltage and becoming more opaque

Electrochromic glass is most effectively used in high-latitude zones where heat gain is not a concern [3] [7] [13] [14].

#### 3.7 Challenges

Despite the many benefits nanomaterials exhibit as described in the previous paragraphs, it is important to mention also some important issues facing the widespread application of these products.

The biggest obstacle is the cost of nanomaterials and new processing technologies. Other important issues are the lack of availability of nanomaterials in large volumes, potential risks and health hazards, absence of awareness in the construction industry about novel products and uncertainty about long-term reliability of nanomaterials properties.

Further scientific research is required to define the hazardous impact of nanomaterials with the aim to reach an adequate risk assessment [15].

#### 4 SUMMARY AND FUTURE PROSPECT

Nanomaterials contribute to sustainable construction by providing high insulating and multifunctional properties that improves energy efficiency in buildings. Furthermore, by reducing the amount of energy and raw materials required in the production process, it contributes to the conservation of resources, and reduction of carbon emissions. Nanotechnology increases the robustness of materials through enhanced resistance to corrosion, fatigue, wear, and abrasion.

Businesses that choose to employ nanotechnology will have to face challenges related to material cost, construction industry awareness and potential health risks.

This paper is a basis for an in-depth research on the role of nanomaterials in advanced glazing systems, examining their energy efficiency, lifecycle cost and environmental impact.

#### 5 REFERENCES

1. Lee, J. et al., Nanomaterials in the construction industry: a review of their applications and environmental health and safety considerations. *American Chemical Society nano*, 2010. 4 (7): p. 3580–3590.
2. Gammampila, R. et al., Application of Nanomaterials in the Sustainable Built Environment in International Conference on Sustainable Built Environment. 2010: Kandy, Sri Lanka. p. 20-27.
3. Elvin, G., Nanotechnology for Green Building (2007) in *Green Technology Forum 2007*. Available from: <<http://www.solaripedia.com/files/915.pdf>>.
4. Leydecker, S., *Nano Materials in Architecture, Interior Architecture and Design*. 2008, Springer Science & Business Media.



5. Leone, M.F., Nanotechnology for Architecture. Innovation and Eco-Efficiency of Nanostructured Cement-Based Materials. *Journal of Architectural Engineering Technology*, 2011. 1:101. doi:10.4172/2168-9717.1000102.
6. Addington, M. and D.L. Schodek, *Smart Materials and New Technologies: For the architecture and design professions*. 2004, Routledge.
7. Schodek, D.L. et al., *Nanomaterials, Nanotechnologies and Design: An Introduction for Engineers and Architects*. 2009, Butterworth-Heinemann.
8. Pacheco-Torgal, F. and S. Jalali, Nanotechnology: Advantages and drawbacks in the field of construction and building materials. *Construction and Building Materials*, 2011. Vol. 25: p. 582-590.
9. Olar, R., *Nanomaterials and Nanotechnologies for Civil Engineering*. The Bulletin of the Polytechnic Institute of Jassy, Construction. Architecture Section, 2011. Fasc. 4: p. 109-118.
10. Pacheco-Torgal, F., et al., *Nanotechnology in eco-efficient construction*. 2013, Woodhead Publishing Series.
11. Ahadi, P., Applications of Nanomaterials in Construction with an Approach to Energy Issue. *Advanced Materials Research*, 2011. Vols. 261-263: p. 509-514.
12. Kaiser, J-P. et al., Nanoparticles in paints: A new strategy to protect façades and surfaces? *Journal of Physics: Conference Series (Online)*, 2013. 429(1), 10. doi:101088/1742-6596/429/1/012036
13. Long, L. et al., Performance demonstration and simulation of thermochromic double glazing in building applications. *Solar Energy*, 2015. 120: p. 55–64.
14. Freire, R.Z., et al., Capacitive effect on the heat transfer through building glazing systems. *Applied Energy*, 2011. 88: p. 4310–4319.
15. Iavicoli, I. et al., Opportunities and challenges of nanotechnology in the green economy. *Environmental Health*, 2014. 13:78. doi:10.1186/1476-069X-13-78





## Expanding Boundaries: Systems Thinking for the Built Environment

### SUSTAINABLE INSULATION SYSTEM BASED ON FABRICS

A. Saur<sup>1\*</sup>, S. Kunz<sup>1</sup>, D. Geissbühler<sup>1</sup>

<sup>1</sup> FG MS A, Lucerne University of Applied Sciences and Arts, Technikumstrasse 21,  
CH 6048 Horw, Switzerland

\*Corresponding author; e-mail: alexandra.saur@hslu.ch

#### Abstract

Nowadays, new as well as refurbished buildings are supposed to be environmentally sustainable with regard to energy consumption, CO<sub>2</sub> emission, occupant comfort and indoor air quality. A research team of architects, civil engineers, designers and economists of our university, including partners from industry (membrane construction, manufacturers of warp-knitted and woven fabrics and of insulating materials), proposes new solutions for the interior insulation of older sports and industrial buildings which no longer meet today's requirements for energy efficiency. The focus for refurbishment concepts, the selection of materials and their application lies on energy efficiency and economy.

The principal object will be a multi-layered construction system based on fabrics and insulation with green attributes. All components of the internal insulating system can be segregated for recycling at the end of the building's life without major effort. Mineral wool from regional stone and recycled mineral wool is used as an insulating material. Thanks to its loose form, the injectable insulating material adapts itself optimally to the most diverse hollow spaces when filling. Every insulation thickness and every geometry can be filled without joints. In addition to excellent thermal properties, the granulated material also has unmatched acoustic and fire retardant characteristics. The innovative "TexLining" system may replace traditional batt insulation by a minimum of materials, production steps and effort while providing superior performance, innovative and adaptable shaping and aesthetic appeal for building design. Because of the named positive aspects, this novel insulation system can be a valuable effort to fight today's energy and CO<sub>2</sub> problems.

#### Keywords:

Novel retrofitting; textile fabrics; thermal comfort; internal building insulation; textile aesthetics

### 1 INTRODUCTION

Energy saving measures will play an increasingly important role in society in future. To fulfil the demanding tasks of today's times, a research team at the Lucerne University of Applied Sciences and Arts, consisting of architects, civil engineers, designers and economists from the Schools of Engineering & Architecture, Design & Art, and Economics is studying the field of the building envelope refurbishment of industrial and sports buildings that were constructed between 1970 and 1990. The research work focuses heavily on current events with respect to the Swiss Energy Strategy 2050. The focus for refurbishment concepts, the selection of materials and their application lies on energy

efficiency, sustainability and economy [1]. Together with our economic implementation partners, such as processors in the field of membrane construction and in the textile and insulation material industry, innovative textile refurbishment concepts are being developed that combine functional properties with aesthetic qualities.

The concept of TexLining is to develop textile interior insulation to improve the energy efficiency of existing hall structures. The textile chamber system is precisely tailored to the existing structure and mounted to create an inner lining. A refurbishing system was developed that uses a combination of materials, finishing and mounting to achieve the highest possible efficiency. Its

application is primarily aimed at girder hall structures. Unlike conventional refurbishing systems, prefabricated refurbishing textiles also have economic advantages due to their very low weight and simple mounting. Produced in ideal conditions that are state of the art in the field of textile processing, they are highly precise and contribute to a good handling quality on the building site.

## 2 MATERIALS AND METHODS

Demands on the selected textiles vary depending on the application. It is essential for the refurbishing system to fulfil technical, structural and aesthetic requirements [1,2,3]. These include tensile strength, density, vapour diffusion, resistance to weathering and fastness to light. Minimum requirements for a textile exterior shell lie in resistance to weathering, tensile strength and UV resistance [4]. By contrast, textile inner linings should have tensile strength and a certain amount of breathability. Available textiles are initially selected and studied together with economic partners. If necessary, textiles must be developed that have specific qualities and can be combined at a later date when applied.

Mineral wool from regional stone and recycled mineral wool is used as an insulating material. The properties of mineral wool fibres are diverse. They have a low thermal conductivity and ideal heat storage qualities. They are also breathable, i.e. water-vapour permeable and do not absorb any humidity, making them resistant to mould, rot and vermin. Non-inflammability and a high melting point round off their numerous properties. They are processed simply and can be used universally, allowing them to be applied in projects as fine granulate in interiors. The fine granulate itself consists of loose, impregnated mineral wool that is blown into the insulating textile chambers through tubes using air pressure. Inaccessible hollow areas are insulated in a joint-free way, thereby reducing energy losses as a result of thermal bridges, which in turn leads to lower heating costs. The high own weight and ideal fibre structure also ensure optimal sound absorption. Depending on the on-site situation, it is possible to do without expensive scaffolding since the insulation blowing work no longer requires any scaffolding to pneumatically apply the material.

To develop the internal insulation system consisting of textiles and mineral wool, it was necessary to design constructive solutions and continuously adapt existing materials to the requirements of the future refurbishment system [5]. One important tool was always physical and practical implementation in material tests, models, mockups and a prototype to examine the theoretical findings (see Fig. 1).

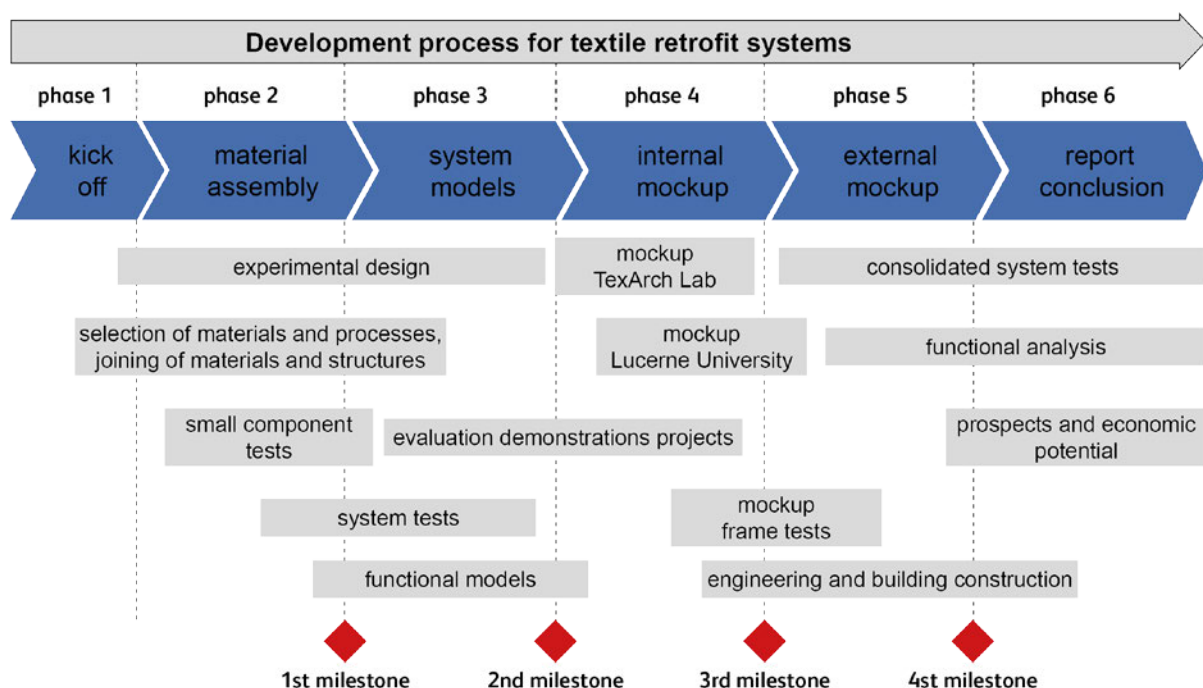

Fig. 1: Development process for textile retrofit systems.

## 2.1 Material combinations

In a first step, an experiment plan was developed that included a wide range of potentially applied materials (textiles and filling materials), processes and joining principles, which served as the basis for conceiving the newly developed textile refurbishing systems [1,6]. Small-scale experiments examined the evaluated textiles and insulating material with respect to their ability to be combined with and integrated in different ways in later systems. At the same time, parallel system experiments were carried out in which construction principles were investigated and assessed. In each series of experiments and at every stage of development, the aim was to weigh up appropriate material combinations and also examine the feasibility and procedure [7].

## 2.2 System models

Based on the results of the small-scale and system tests, this stage of system development focused on larger models. Various functional models were used to develop the textile chamber system with respect to the optimized use of materials, production and interaction between materials. The architectural and aesthetic potential of the refurbishing system was evident in its production, dimensioning and the surface of the outer layer. Using scaled models, the posited working theses were investigated and tested, as well as evaluated with respect to their plausible implementation. To create a sturdy envelope for the mineral granulate, textile layers had to be bonded to produce a double membrane. During system model development, two versions proved to be expedient. In Version 1 the entire envelope was divided by sewing vertical strips inside to create chambers. In Version 2, the two membranes were joined at selective points using pins, in a method similar to the production of upholstery.

## 2.3 Internal mockups

To make the system development as similar to real conditions as possible, experiments with differently sized mockups on a 1:1 scale followed. The effective behaviour of the materials was investigated using an initial test stand measuring 2.0m x 1.5m (HxW) in the TexArchLab, allowing tests with respect to details of fixing and mounting. During the development process, it was necessary to produce another test stand measuring 5m x 1.5m to simulate actual implementation and test the structural requirements of the future system. This mockup allowed us to test the mounting conditions and the filling of the mineral wool granulate in a realistic way. With respect to the surface finish and mounting elements, it was possible to draw more precise conclusions on their visual effect.

In an additional measure, the textile system was given an integrated vapour barrier in the form of an applied foil. This allowed the textile system to adapt to different existing building structures and make the vapour diffusion processes controllable in future. An additional test frame on a 1:1 scale served to technically record structural values such as the elasticity modulus, shear modulus, wall friction coefficients, pretension, and the filling pressure of the fine granulate on the textile.

## 2.4 External prototype

The final test for the textile refurbishing system was the prototype in an existing hall, in which all findings were integrated (see Fig. 2). This required adapting the textile refurbishing system to existing local conditions. Many aspects that could be influenced directly in the mockups existed in the prototype. For instance, access for filling the insulation material must be conceived in a practically specific way.

## 3 RESULTS AND CONCLUSIONS

The analysis of the existing buildings showed that for larger structures with a low proportion of windows, refurbishment from the inside is more feasible, while buildings with a large amount of windows and small rooms are more easily insulated from the outside. Furthermore, it became evident that some studied buildings had only little or no load-bearing reserves. That meant the textile refurbishing system required a considerable weight reduction or structural strengthening for the existing building.

Since the economic partners in the textile industry do not yet produce textiles for the building industry for use as described in this case, it became clear that the selected fabric and mesh required a variety of optimization measures. These included controlling vapour diffusion by means of an appropriate foil, good processing properties and structural burdens, which are only some of the optimization factors.

As the findings of the mockups show, weight reduction and optimizing thermal conductivity are decisive improvement factors for the mineral wool granulate.



*Fig. 2: Prototype of the textile retrofit system.*

The textile refurbishing system must be able to react very specifically to the existing building. Not only the access details can vary very greatly depending on the building, but also the chosen insulating measures. Additional heat insulation always leads to a change in the hygric conditions in the building section due to the close interaction between warmth and moisture. Great attention should be paid to moisture management to prevent moisture gradually building up within the construction over the course of time. Generally, two interior insulation system types should be considered. An investigation of capillary-active and vapour-permeable systems was not possible in the time frame of the project. Thus the focus was on vapour-impermeable and vapour-barrier systems. In such cases, insulation with a high vapour barrier should be applied from the inside. The layer can consist of a modified insulating material, a textile with an applied vapour barrier foil, or appropriate vapour-impermeable layers.

The textile refurbishing system provides decisive advantages on several levels compared to conventional methods. In developing a basic logic for the joints, it is possible to react to different conditions. The low thermal conductivity of interior insulation increases the surface temperature in the interior space and therefore improves the comfort level. Thermal comfort levels improve, especially in temporarily used spaces, since they can be heated quickly. With respect to the acoustics, textile surfaces combined with mineral wool granulate achieve an

audible improvement of reverberation times, which is especially useful in sports halls. The new surfaces also offer diverse aesthetic advantages due to the textile look and feel. With respect to economic aspects, the fast mounting of prefabricated textiles and the small number of working steps lead to a considerable added value compared to conventional refurbishing systems. A wide range of refinement methods in textile processing also enables the economic production of complex geometries, as already applied in the clothing industry or in upholstery making. That represents a high level of creative potential and also the chance to adapt to the individual form of the existing building.

#### 4 ACKNOWLEDGMENTS

This work was financially supported by Commission for Technology and Innovation CTI (project funding no. 14790.2 PFES-ES). We gratefully acknowledge the technical support and assistance of our implementation and research partners.

##### 4.1 Implementation partners

- HP Gasser AG: Membrane construction and textile architecture
- Flumroc AG: Manufacturer of insulating materials
- swisstulle AG: Manufacturer of warp knitted fabrics

- TISSA Glasweberei AG: Manufacturer of fibreglass textiles for industrial applications
- Dr. Lüchinger + Meyer: Civil engineering and structural design

#### 4.2 Research partner Lucerne University of Applied Sciences and Arts

- Departement Engineering & Architecture: FG Material & Structure in Architecture, CC Façade Engineering and Metal Construction
- Departement Art & Design: FG Products & Textiles
- Departement Business: CC General Management

#### 5 REFERENCES

1. Saur, A. Textiler Verbundwerkstoff als Putzersatz für Wärmedämmverbundsysteme. Dissertation, Universität Stuttgart 2009.
2. Haase W, Klaus T, Knubben E, Mielert F, Neuhäuser S, Schmid F, Sobek W. Adaptive mehrlagige Gebäudehüllen. Stuttgart: Fraunhofer IRB Verlag; 2011.
3. Saur, A. et al. Einsatz innovativer Textilien und Funktionsmembranen für energetisch optimierte Fassaden- und Klimasysteme. Forschungsbericht, IBP-Bericht RKB 004/2010/292. Stuttgart 2010.
4. Grunwald G. Mechanisch vorgespannte, doppelagige Membranmodule in ihrer Anwendung als zweite Gebäudehülle. Dissertation, Technische Universität Berlin 2007.
5. Saur, A.; Sedlbauer, K. New Innovative Textile Coating Systems for Buildings. Proceedings of 6th Techtexil North America Conference, Las Vegas, 2009.
6. Seidel, M. Textile Hüllen. Bauen mit biegeweichen Tragelementen. Berlin 2008.
7. Koch, K.-M. Bauen mit Membranen. München: Prestel Verlag, 2004.







## Expanding Boundaries: Systems Thinking for the Built Environment

### ECOLOGICAL PERFORMANCE OF TIMBER / WOOD-CEMENT COMPOUND COMPOSITE SLABS

M. Maeder<sup>1</sup>, D. Zwicky<sup>2\*</sup>

<sup>2</sup>Institute of Construction and Environmental Technologies (iTEC)

<sup>2</sup>School of Engineering and Architecture, Fribourg (HEIA-FR)

<sup>1</sup>University of Applied Sciences and Arts of Western Switzerland (HES-SO)

\*Corresponding author; e-mail: daia.zwicky@hefr.ch

#### Abstract

Wood-cement compounds (WCCs) have been being used in construction since the beginning of the 20<sup>th</sup> century, mostly as a secondary structure or finishing layers such as sound or thermal insulation elements. However, WCCs' stiffness and strength are rather low, therefore WCCs should be combined with timber or a similar light-weight structural material used as a load-bearing element. The use of WCC for composite elements allows to take advantage of both materials, particularly of the strength of timber and the insulation properties of WCC. Furthermore, WCC slab elements do only require a minimal secondary structure due to their beneficial sound and thermal insulation properties. This paper reports on a life-cycle assessment (LCA) where those new and promising composite slab elements have been compared to traditional concrete, wood and timber-concrete composite (TCC) slabs regarding greenhouse gas emissions (EGG), non-renewable primary energy (NRPE) and environmental impact points (UBP).

#### Keywords:

Wood-cement compounds; sound and thermal insulation; life-cycle assessment

## 1 INTRODUCTION

Concrete is one of the most widely used construction material. Unfortunately, the use of non-renewable resources has an important impact on concrete's life-cycle assessment (LCA). Whereas wood-cement compounds (WCCs) are a mixture of hydraulic binder with wood waste (e.g. sawdust) and thus have a lesser influence on eco-balance. WCCs have been being used in construction since the beginning of the 20<sup>th</sup> century mostly as secondary-structure, but are also known for their good sound and thermal insulation properties. To use WCC in a load-bearing structure, several investigations were made to develop and test pourable WCC recipes [1]. Their performance, when used in a load-bearing composite system, has been analysed in another study [2].

Another study [3] has also investigated the sound and thermal insulation properties of wood-cement compounds and timber-WCC composite (TWCCC) elements. Based on a life cycle

assessment (LCA) [2], the used cross-sections needed to be modified with regard to verifying the Serviceability Limit State (SLS), Ultimate Limit State (ULS) and accidental situation of fire exposure.

A detailed LCA has been established for two TWCCC slabs in order to compare the results with a case study [4] on concrete, timber and TCC slabs.

## 2 CONSIDERED SLAB TYPES

The present LCA compares five different 9.0 m single span slabs. Concrete, wood and TCC slabs originate from case study [4]. The cross-sections of these three conventional slabs have not been modified for this LCA. The TWCCC slabs are similar to slab types 2 and 5 from [2]. The other slab types (type 1, type 3 and type 4) are not considered in this LCA, because type 2 and type 5 are the most promising configurations to use as load-bearing flexural element.

Type 2 is characterized by timber beams embedded in WCC and type 5 by a '+/-' shear-connection provided by a glulam slab. The analysed TWCCC slabs are shown in Figure 1.

Test results [2] have shown that ULS performances are insufficient for these two TWCCC slabs. Considering SLS, the results show a satisfying performance if deflection due to deadload is compensated by camber. For that reason, the two TWCCC slabs had to be modified such that all limit state performances are sufficient. In addition to the study from Eymard and Zwicky [2], fire exposure has also been taken into account. For the dimensioning of these new slabs, the latest results from an analytical study on 6-point bending tests were used (results not published yet).

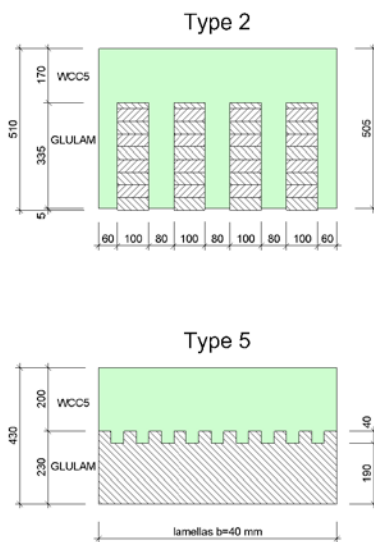

Fig. 1: New WCC slabs: cross sections.

Fire resistance class was stipulated as R60. The combustion rate for solid wood is about 0.8 mm/min [5].

The new cross section of type 2 requires timber beams  $h=340$  mm to verify ULS. This section is unusual for solid wood which is why this slab requires glulam beams instead of solid wood.

Furthermore, both TWCCC slabs are used with only one WCC recipe (WCC5 [1]). The study from Eymard and Zwicky [2] considered a different recipe for each slab.

Note that these cross-sections have never been tested experimentally. They are only indicative and serve as basis to compare this LCA with the case study [4].

## 2.1 Materials properties

Compared to the previous analyses, new material properties are used here. The WCC5 recipe [1] has not been changed, only its mixing process was optimized. The following WCC properties were used for preliminary design of the new slabs:

- $f_{cm} = 10$  MPa
- $E_m = 1000$  MPa
- $\rho = 11.1$  kN/m<sup>3</sup>

## 2.2 Building code requirements

For preliminary design, all limit states have been considered. Test results showed [2] that SLS is not governing for the considered TWCCC slabs. This is why, first of all, these two slab types were designed to offer the required verification for ULS. Afterwards, the SLS and accidental situation of fire exposure were considered. All verifications were made in accordance with [6].

As already mentioned the fire resistance class is R60 and for both WCC slab types, the combustion rate is about 0.8 mm/min, even though both TWCCC slabs are made of glulam.

For SLS verification, deflection can be compensated by a camber and variable actions should not cause a deflection higher than  $L/350 = 26$  mm. To remain comparable with earlier results [4], the same variable action of 5 kPa is considered (category C3 according to SIA 261 [6]).

The following table shows which load has to be considered for each type and limit state, respectively.

Type	Limit State	$q_{Ed}$ [kN/m <sup>2</sup> ]
Both	SLS	2.66
Type 2	ULS	11.90
Type 5	ULS	10.70
Type 2	Fire exposure	4.80
Type 5	Fire exposure	4.65

Table 1: Considered loads.

## 3 ECO-BALANCE

The mentioned case study [4], which investigated the environmental footprint of different slab types, serves as a basis for the present LCA. For both studies, the span ( $L = 9.0$  m) forms the common reference so that the data can be compared.

The major differences between the earlier study [2] and this report are the modified cross sections from the two WCC slabs as well as the use of only WCC5 [1] for both slab types.

All environmental influences have been calculated with the CFSC 2014 [7] life cycle assessment data. Furthermore, the earlier results [4] have been updated because they were based on CFSC 2012 LCA data.

The LCA considers a service life of 90 years, further considering that all secondary structures are taken into account 3 times (1x new construction, 2x replacement).

### 3.1 Considered parameters

For all slab types, the necessary secondary structure, which is needed to meet the building

requirements (e.g. sound insulation) is considered. The analysed parameters are separated in two subsections, load-bearing structure and secondary structure. The designs for the concrete, wood and TCC slabs are to be found in [4]. The TWCCC slabs only require a constructional screed layer (50 mm) to respect the requirement concerning impact noise level. The internal and external airborne sound levels do not cause any difficulties and no additional materials are needed as secondary structure [2].

### 3.2 Results

The sequence of calculation of the different environmental impacts is separated in 2 steps. First of all, the load bearing structure has been analysed and subsequently, the secondary structure and the transport of all materials have been added to the previous results. Figure 2 shows that transport has a minimal influence on the final result of all considered slab types. Therefore, this parameter is no longer considered to determine the environmental impact.

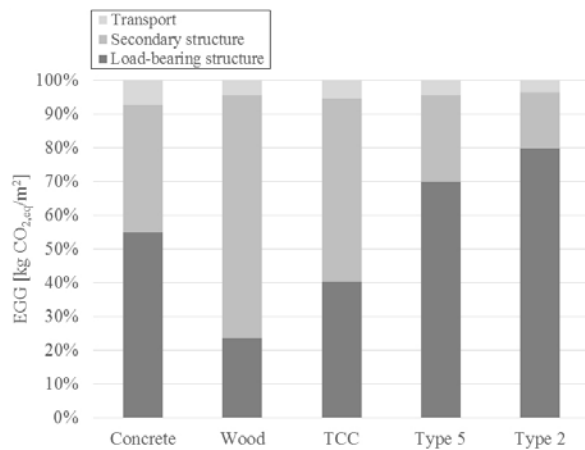

Fig. 2: relative EGG.

As shown in Figure 2, the secondary structure of both TWCCC slabs has the smallest influence of all analysed slab types on the relative amount of EGG. This is, as already mentioned, due to the high sound insulation capacity and thus a constructional screed is enough. On the other hand, the absolute EGG values, regarding only the secondary structure, are comparable to a conventional concrete slab. Figure 3 illustrates the comparison of all considered slabs.

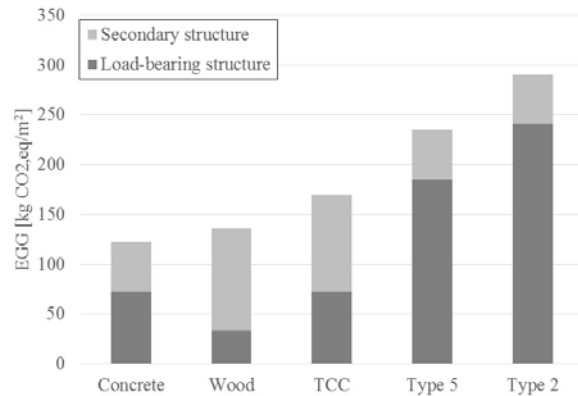

Fig. 3: EGG for different slab types.

As shown in the above Figure 3, type 2 represents the biggest total amount of EGG per square meter. Its value is more than twice the value of a concrete or wood slab and also significantly higher than EGG of a TCC or type 5 slab. This is due to the WCC recipe [1], which has a considerably higher cement content than a conventional cement recipe. Furthermore, glulam has a bigger environmental impact than solid wood. Another reason for the big difference between the TWCCC slabs and all other slabs, is the high volume of WCC.

In contrast to the study from Eymard and Zwicky [2], type 5 shows a better performance than type 2. This is due to the fact that type 2 now requires a glulam beam instead of solid wood. However, a comparison of non-renewable primary energy values shows that the difference is less obvious. Although the concrete slab needs the least amount of non-renewable primary energy, the type 2 can close the gap on the other four considered slabs.

Figure 4 shows the total amount of non-renewable primary energy required per square meter.

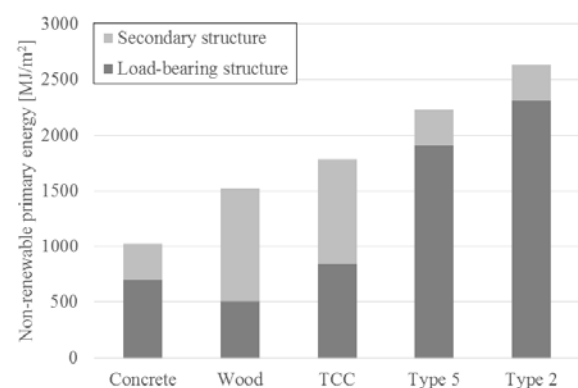

Fig. 4: non-renewable primary energy.

As already mentioned, the need of glulam has a strong influence on the results of type 5 and type 2 as well as the used WCC volume. A recent study [8] demonstrates that WCC can be combusted and thus allows to recover energy. This LCA is based on the values from [8] which

means that WCC5 releases 3 MJ/kg and timber 9 MJ/kg during combustion. This means that a part of non-renewable primary energy can be reused and that has a positive effect on the balance of non-renewable primary energy. Figure 5 illustrates the total amount of non-renewable primary energy if combustion is taken into account.

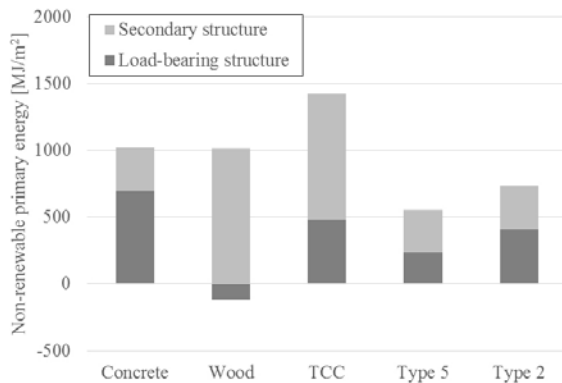

Fig. 5: total amount non-renewable primary energy.

It is obvious that both TWCCC slabs require less non-renewable primary energy for their life cycle than the other conventional slabs.

Another comparison can be made by means of environmental impact points (UBP). The UBPs 2013 quantify the environmental footprint caused on the use of energy- and material resources, of land and fresh water, by emissions into air, water and soil, by tipping of waste and by traffic noise.

Figure 6 shows this comparison with relative UBP values where the concrete slab serves as reference.

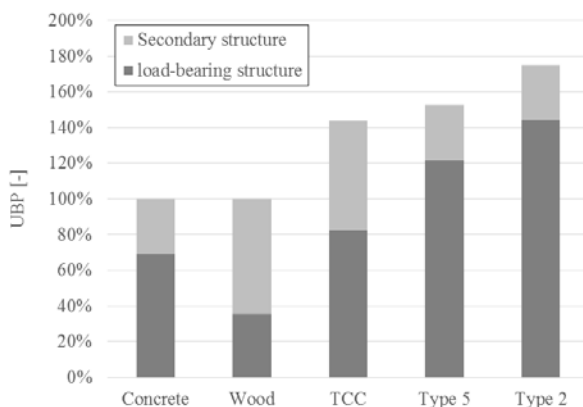

Fig. 6: relative UBP.

The environmental impact of all slabs can be roughly divided into two groups: concrete and wood as well as TCC, type 5 and type 2, respectively. The secondary structure of both TWCCC slab types has little impact on the life cycle assessment (Figure 2). Nevertheless, type 2 shows a bad performance compared to all other slab types, particularly concrete and wood slab.

This is due to the fact that the used WCC5 recipe has a high cement content and to the use of glulam beams. Note that the advantage of energy recovery is not included in UBP calculation.

#### 4 CONCLUSION AND PERSPECTIVES

Generally speaking, the TWCCC slab type 2 is not competitive against the other construction methods if we consult the different LCA parameters. There is a great deal of unexploited potential regarding EGG and UBP values of type 2. The cement content plays a central role. However, if the non-renewable primary energy values are compared, one realizes that both TWCCC slabs are much more energy-efficient than the other conventional slabs. Particularly, type 5 shows a great performance with a very little proportion of non-renewable primary energy left at the end of life cycle. These results also show that ecological performance evaluation also depends on the referred index.

This advantage is due to the WCC containing sawdust which gives the possibility to combust the used WCC at the end of service life and this process allows an energy recovery. This effect would be even more pronounced if another WCC recipe would be used [2].

The aim must be that both TWCCC slabs can close the gap on the others, in particular regarding EGG and UBP. There are two ways of doing this:

On the one hand, the cement content plays a crucial role. A positive effect on LCA data for TWCCC slabs is produced by reducing the mass of cement used for construction. This, though, is not that simple because this parameter also directly influences all other material properties (strength, stiffness etc.).

On the other hand, the global amount of materials influences the LCA results. As the cross-sections of both TWCCC slabs had to be increased (compared to their original cross section), there is a need for optimizing the shear connector in order to reduce the mass of WCC needed. That way, it is possible again to use solid wood for type 2. This would have another positive effect on LCA data.

In conclusion, both TWCCC slab types show an interesting life cycle assessment performance and provide an alternative solution to conventional slabs, which are already nowadays far ahead regarding non-renewable primary energy. Moreover, TWCCC slabs meet all building code requirements, particularly airborne sound level, with a minimum of effort. The great thermal insulation capacity is an additional benefit.

## 5 ACKNOWLEDGEMENT

The funding received from the national research program 66 'Resource Wood' [grant no. 406640\_136918/1] of the Swiss National Science Foundation is gratefully acknowledged. This research project is a collaborative effort of the School of Engineering and Architecture of Fribourg and Vienna University of Technology. The authors also wish to thank University of Applied Sciences of Western Switzerland for the additional financial support and our industrial partner ERNE AG for its support and expertise in conceptual design and provision of test specimens.

## 6 REFERENCES

1. D. Zwicky, Mechanical properties of wood-cement compounds, in Proc. 10th Conference on Advanced Building Skins. November 2015: Berne, Switzerland.
2. M. Eymard and D. Zwicky, Slab elements made of timber and wood-cement compounds – structural and other performances, in Proc. 3rd International Conference on Structures and Architecture ICSA. July 2016: Guimarães, Portugal. (Submitted for consideration for publication)
3. A. Fadai and W. Winter, Thermal and acoustic insulation properties of wood-cement compounds, in Proc. 10th Conference on Advanced Building Skins. November 2015: Berne, Switzerland.
4. Y. Plüss and D. Zwicky, A case study on the eco-balance of a timber-concrete composite structure in comparison to other construction methods, in Proc. Concrete Innovation Conference. June 2014: Oslo, Norway.
5. SIA 265, Timber structures. Zurich: Swiss Society of Engineers and Architects, 2012.
6. SIA 261, Actions on structures. Zurich: Swiss Society of Engineers and Architects, 2003.
7. Coordination of the Federal Service of Building and Real Estate (CFSC). Empfehlung, Ökobilanzdaten im Baubereich. 2009/1. 2014: Berne Switzerland.
8. D. Zwicky, Combustibility of wood-cement compounds, in Proc. 10th Int'l Conference on Advanced Building Skins. November 2015: Berne, Switzerland.





## Expanding Boundaries: Systems Thinking for the Built Environment

### FILTER FACADE

F. Oswald<sup>1\*</sup>

<sup>1</sup>Institute of Architecture Technology, Graz University of Technology, Rechbauerstr.  
12/I, 8020 Graz, Austria.

\*Corresponding author; e-mail: Ferdinand.oswald@tugraz.at

#### Abstract

The *Filter Facade* research project has the goal of reducing air conditioning (air conditioner split units) usage in buildings by cooling the interiors of residential high rises (see fig. 03) in subtropical climate regions with natural cross ventilation by optimizing the wind-flow using architectural components with specific openings such as the *Filter Facade*.

#### Keywords:

Reduce A/C; air conditioning; thermal comfort; natural ventilation; subtropical climate regions; optimizing wind-flow; architecture components; specific openings; noise pollution; air filtering; controllable opening cross-section; Filter Façade

### 1 INTRODUCTION

The damp sub-tropical climate of the south-eastern Chinese coastal region has led to the use of air-conditioning systems ensuring a comfortable 50%-moisture indoor climate in combination with a temperature of 22 °C. The outdoor air moisture and temperature intensity are almost double these values. Compared with heating systems, air-conditioning systems require almost triple the energy input, and through their waste heat, they cause significant further warming of the urban space (40% of the energy is released in ambient air in the form of waste heat), while the systems themselves frequently overheat due to their excessively sealed surface areas (Heat Island Effect).

Air conditioning systems are exacerbating the urban heat island effect [1] in cities already suffering from overheating due to increasing ground sealing and the heat accumulating function of building substance [2].

The 150 million inhabitants in the south-eastern Chinese coastal region require 145 GWh per year to cool their homes by means of air conditioning [3]. If predictions regarding

immigration to Chinese conurbations are to be believed, and if the current air-conditioning standards are maintained, energy demand will double [4]. Above all, this trend means an ecological challenge, which is directly linked to questions on energy production and the urbanization of major regions.

It is possible to optimize thermal comfort by using natural ventilation. Results from specific research projects [5] and from the dissertation at the Institute of Architecture Technology [6] have clearly demonstrated this. Scientific measurement has furthermore produced evidence that specific natural cross ventilation can optimize human behaviour for periods of up to 90 % of the year (e. g. Hong Kong) [7] (see fig. 1.1 and 1.2).

Should the possibility exist to provide natural ventilation for the inhabitants of an urban area, the question of possible polluted air in big cities arises together with the associated prohibition on the opening of windows. The search for solutions to these problems and also the problems of noise, air filtering, and sun protection are analysed in the case studies of this paper.

## Psychrometric Chart

Location: Hong Kong, China  
 Data Points: 1st January to 31st December  
 Weekday Times: 00:00-24:00 Hrs  
 Weekend Times: 00:00-24:00 Hrs  
 Barometric Pressure: 101.36 kPa  
 © Weather Tool

1. passive solar heating
2. thermal mass effects
3. exposed mass + night-purge ventilation
4. natural ventilation
5. direct evaporative cooling
6. indirect evaporative cooling

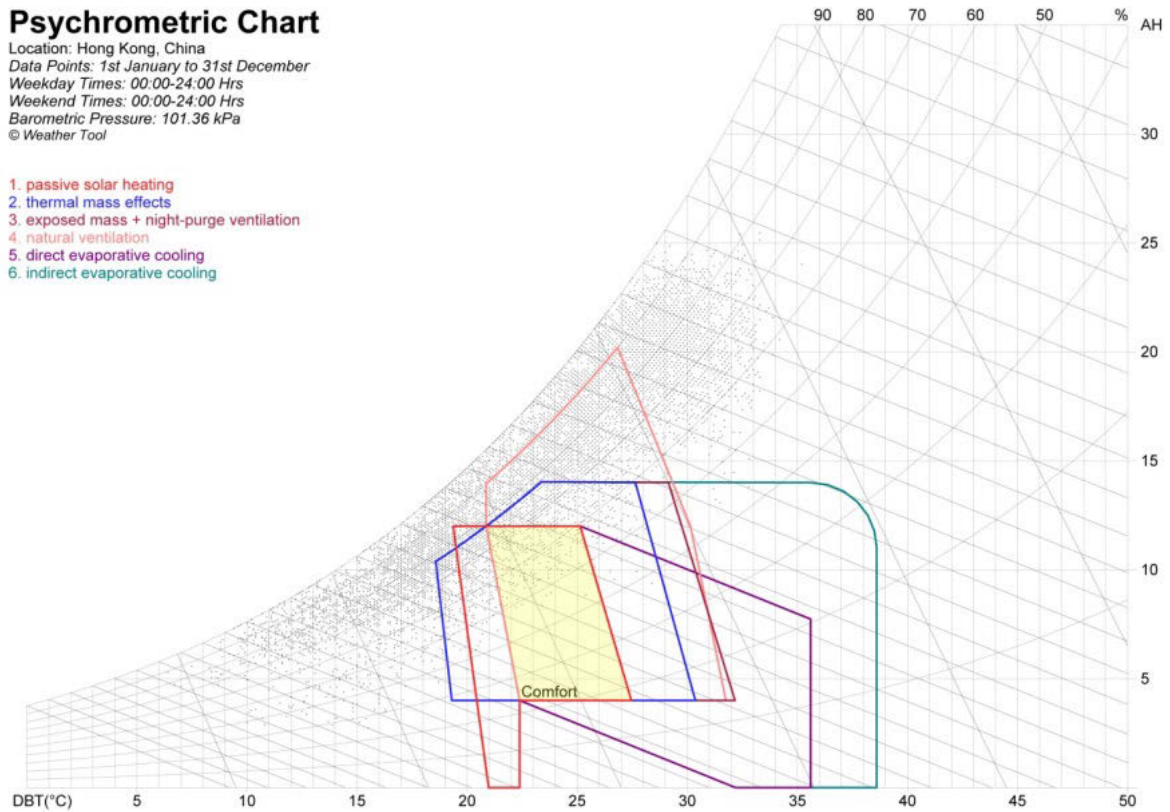

Fig. 1.1: Psychrometric chart of Hong Kong's comfort zone showing change due to natural ventilation (pink) and other methods of passive ventilation. Source: Weather Tool 2001, © Autodesk, Inc. 2010; Weather data Download, U.S. Department of Energy, report on the data (STAT) and ASHRAE Design Conditions Design Day Data file (DDY).

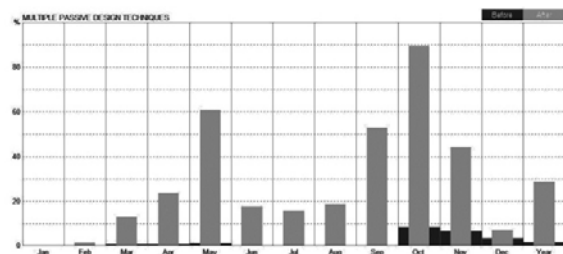

Fig. 1.2: Percentage of comfort throughout the year and per month achieved through natural ventilation in Hong Kong, data from psychrometric chart. Source: Weather Tool 2001, © Autodesk, Inc. 2010; Weather data Download, U.S. Department of Energy, report on the data (STAT) and ASHRAE Design Conditions Design Day Data file (DDY).



Fig. 3: Residential high riser Hong Kong, photo © Ferdinand Oswald 2013.



## 2 METHODS

The methodology of this paper is, in a first step to analyse the locations and sites of air pollution worldwide. The second step discusses existing opening systems and their performance as a result of filtering and natural ventilation. The third investigative step points to solutions for problems resulting from traffic noise pollution and examines how natural ventilation performance can be optimised by making use of floor plan configuration and solar radiation. The conclusion presents a review of future research topics and examines potential solutions.

### 2.1 Inhalable coarse particles

Particulate matter (PM) is measured in micrograms per cubic metre. The size of the particles has a direct link to their potential for causing health problems. First among these are the particles of 10 micrometres in diameter or less, because these are the particles that generally pass through the throat and nose and enter the lungs. Once inhaled, these particles can affect the heart and lungs and cause serious health problems. "Inhalable coarse particles," are those such as are found near roadways and in the vicinity of dust-intensive industries, these are larger than 2.5 micrometres and less than 10 micrometres in diameter.

### 2.2 Fine particles

The second group are the "fine particles," such as those found in smoke and haze, these are 2.5 micrometres in diameter and smaller. These particles can be directly emitted from sources such as forest fires, or they can form when gases emitted from power plants, industries and automobiles react in the air.

### 2.3 Existing openings systems

Current possibilities for filtering polluted air using different types of opening systems is an issue in need of discussion. I thus evaluate recently developed opening systems in terms of their efficiency in filtering polluted air, as also in achieving noise reduction, solar income and natural ventilation in residential buildings.

## 3 RESULTS

### 3.1 Air pollution in cities

The illustration shows the statistical range for air pollution worldwide from 2006. Particulate matter 10 micrometres in diameter is shown in yellow and the nitrous oxide emission in a thousand tonnes of CO<sub>2</sub> equivalent is shown in violet. The bigger particulate matter with the size of 10 PM often occurs in developing countries in Africa, India and Middle East. This problem is further exacerbated due to the fact that these regions are frequently arid, sandy and have roads that are not asphalted. The Nitrous oxide emissions (NOE) shown in violet, are the "fine particles,"

such as those found in smoke and haze, they are 2.5 micrometres in diameter and less. These are more difficult to clean and are present to a significant extent in the following areas: The southeast coastal region of China is heavily affected and European cities such as Paris, Stuttgart or Graz have high NOE values due to heavy automobile traffic and the special features of their locations. The results of this research are thus also suitable for use not only in the southeast coastal region of China but also in European cities.

The inhalable coarse particles can be easily filtered by G1-G4 filter-systems (coarse dust filter class). The fine particles are more difficult to filter. This can be done using filters of the F5-F9 (fine particle filter class).

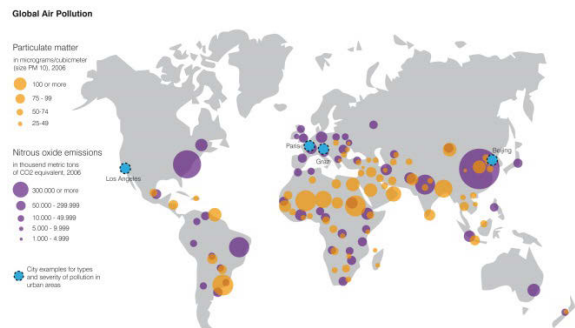

Fig. 3: Air pollution worldwide Source: © Institute of Architecture Technology, TU Graz, Austria, 2014.

## 4 DISCUSSION

We now move on to discuss existing opening systems and their performance in the contexts of filtering, noise pollution, floor plan configuration and natural ventilation.

### 4.1 Existing opening systems

A ventilation system is currently available on the market from the company Schüco *VentoTec* (see fig. 4). It uses filters of the fine particle filter class F7, and as a result can clean fossil fuels, forest fires and pollen pollutants from the air. The disadvantages of this ventilation system are as follows:

- The system is customized for office building usage and not for the residential use we propose to develop.
- It is a mechanical equipment set, which is powered by an electric motor and thus requires both an electricity supply and technical servicing and maintenance.
- A balustrade it is also required as housing for the equipment in a building.
- The air speed is not sufficiently high to ensure thermal behaviour inside the living space.
- The system is high-tech and thus cost-intensive.



Fig. 4: VentoTec, © Schüco International KG, Germany.

Another existing window system which I would like to introduce here, is the conventional window system used in contemporary residential high rises in China (fig. 5). These have the following features:

- The system is customized for residential building usage in very high production piece numbers.
- The window wings are easily moved and can be fixed in different positions. This is a big advantage due to the different wind directions and wind speeds, which must be used for natural ventilation and it is an absolute “must” for the important possibility of controlling the opening cross section.
- They have single glazing only, a disadvantage due to solar heat income.
- The clientele for these units is working class, and as a result the openings are made cost-efficient and cheap to buy (low-tech).
- This window typology is thus lacking in the capability for the filtering of dirty air and reduction of traffic noise load features.



Fig. 5: Existing windows at Ngau Tau Kok Estate in Hong Kong, architect Hong Kong Housing Authority, Photo © Ferdinand Oswald, 2014.

#### 4.2 Optimized Natural Ventilation

The natural ventilation performance (wind speed) also depends on the floor plan configuration. In figure 6 the modified floor-plan Harmony residential typology (architect: Housing Authority Hong Kong) from IAT can be seen. In the wind study and wind simulation conducted it has emerged clearly that effective natural ventilation is more efficient when cross ventilation is used throughout the complete living unit. This research was carried out by the Institute of Architecture Technology [8].

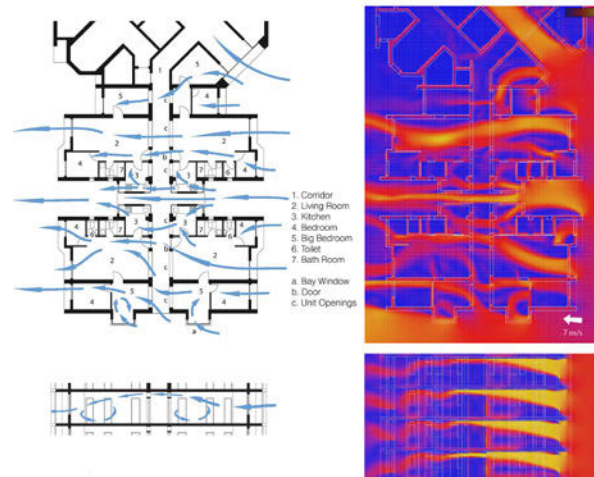

Fig. 6: Wind study and wind simulation for cross ventilation, floor plan and section © Institute of Architecture Technology, TU Graz, Ferdinand Oswald, 2013.

### 4.3 Noise Pollution

Noise pollution is a serious problem when residential estates are located close to automobile infrastructure facilities, such as expressways, main city roads or highways. The illustration is a diagrammatic representation of the Acoustic Balcony which was developed by the Housing Authority 2013. Here the noise load is reduced using 3 different methods. These are:

- arc screens (glass fins)
- perforated acoustic wall panels in the winter garden
- diagonal, staggered opening configuration

The result of these three methods was reduced noise load income (Decibel = dB) into the living unit. The measured noise is outside 80.8 dB and within 56,0 dB which is a noise reduction of 24.8 dB. This has been worked out by an evaluation of the Institute of Architecture Technology in cooperation with the Hong Kong Housing Authority [9].

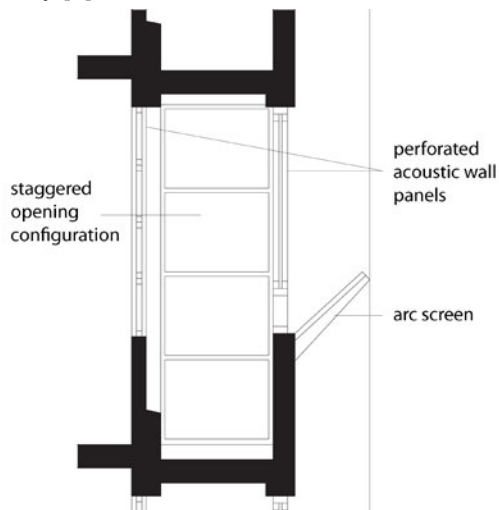

Fig. 7: Section Acoustic Balcony © Hong Kong Housing Authority, graphics modified by © Ferdinand Oswald, 2013.

### 4.4 Sun protection

The Met residential high rise project in Bangkok has no shading devices, although there is total glazing (from bottom to top) without significant solar heat income problems. This is explained by two main causes:

- The building openings are north and south orientated. Due to its location in Bangkok (13.8° latitude – Central Thailand) direct solar radiation here mainly from the west and the east.
- The building structure (reinforced concrete cantilevering elements) causes shadow to fall on the glazing in the openings (see fig. 8).

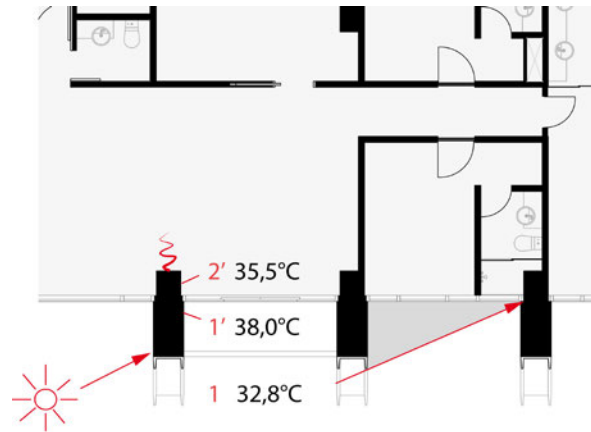

Fig. 8: The building structure causes shadow to fall on the glazing, the MET residential high rise Bangkok, floor plan unit 29th floor © WOHA architects, graphics modified by © Ferdinand Oswald, 2013.

### 4.5 Future research

The existing window opening system demonstrates that there is a significant need to develop a system which is both affordable for the working class client (cost efficient) and which can also fulfil the requirements as explained above. The fine particle filter class F7 air filter has the capacity to clean the air pollution encountered in big cities, but the problem of a massive air-flow filter resistance still arises. The wind speed is reduced significantly by the filter. It is thus necessary to optimize the natural ventilation by modifying the opening and façade system in a preliminary step. We can imagine one solution to this could be in the re-development of the box-type window. In combination with an intelligent façade structure the solution could result in the emergence of an entirely new *filter façade*.

The box-type window has good possibilities for:

- Optimizing natural ventilation including reaction to different wind directions and wind loads
- Reducing the traffic noise that can be heard
- Integrating a filter for cleaning polluted air

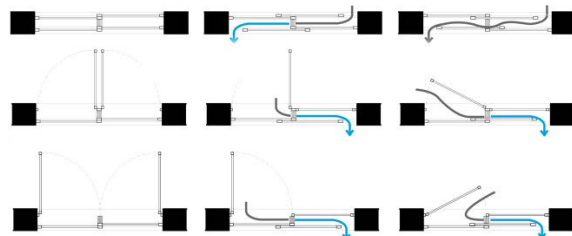

Fig. 9: Box-type window studies Source: © Institute of Architecture Technology, TU Graz, Austria, 2014.

## 5 CONCLUSION

A single solution exists for each problem issue. The requirements of noise, air filtering, a controllable opening cross-section, as well as sunlight penetration, sufficient daylight and rain protection must all be achieved with this *filter facade*. This will require a *filter façade*, however, which is capable of meeting all of these needs simultaneously. The Institute of Architecture Technology is continuing this research in cooperation with the Hong Kong Housing Authority.

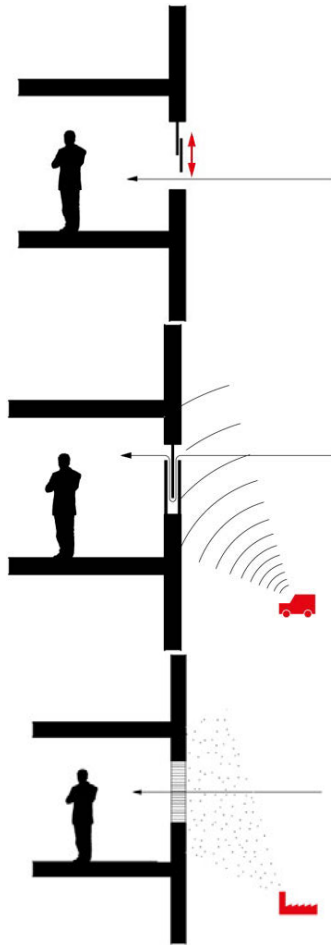

Fig. 10: Natural ventilation requirements for openings in urban area: optimized and controlled natural ventilation, protection for noise and air-pollution, © own diagrams by Ferdinand Oswald, 2014.

## 6 REFERENCES

1. Urban Heat Island Effect: spatial temperature differences with a higher mean temperature in cities compared to their rural surroundings (excess temperature of approx. 0.5 – 1.5 K). Source: Leitfaden Nachhaltiges Bauen, Bewertungssystem für Nachhaltiges Bauens vom Bundesministerium für Verkehr, Bau- und Stadtentwicklung der Bundesrepublik Deutschland. 2013.
2. EIKE – Europäisches Institut für Klima und Energie, Raimund Leistenschneider, *Der Wärmeinseleffekt (WI) als maßgeblicher Treiber der Temperaturen*: <http://www.eike-klima-energie.eu/klima-anzeige/der-waermeinseleffekt-wi-als-massgeblicher-treiber-der-temperaturen/> (retrieved 29/10/2012).
3. Lang S. et al., Progress in energy-efficiency standards for residential buildings in China, *Energy and Buildings* 36, 12 (2004), p. 1191–1196.
4. Office of Dissemination, China Statistics Press, National Bureau of Statistics of China, *China Statistical Yearbook 2011*, Peking 2012, p. 93.
5. Wang L.: „Applying Natural Ventilation for Thermal Comfort in Residential Buildings in Singapore“, in: *Architecture Science Review* Volume 50.3 (2007), p. 224-233.
6. Oswald, F., *Reduce A/C - Reducing the utilisation of air conditioning in high-rise buildings in subtropical and tropical climate regions*, TU Graz Verlag, 2016, Author: Univ. Projektass. Dr. techn. Dipl. Ing. Ferdinand Oswald, Editors: Univ. Prof. Arch. DI Roger Riewe and Ferdinand Oswald, Institute of Architecture Technology (IAT), TU Graz, 392 pages.
7. *Weather Tool 2001*, © Autodesk, Inc. 2010; Weather data Download, U.S. Department of Energy, report on the data (STAT) and ASHRAE Design Conditions Design Day Data file (DDY).
8. Oswald, F., *Reduce A/C - Reduzierung der Klimaanlage-nutzung in Wohnhochhäusern in subtropischen und tropischen Klimaregionen*, Doktorarbeit, 2015, Graz, Austria, p 549.
9. Oswald, F., *Reduce A/C - Reduzierung der Klimaanlage-nutzung in Wohnhochhäusern in subtropischen und tropischen Klimaregionen*, Doktorarbeit 2015, Graz, Austria, p. 571.



## Expanding Boundaries: Systems Thinking for the Built Environment

### SPHERICAL MOTION AVERAGE RADIANT TEMPERATURE SENSOR (SMART SENSOR)

E. Teitelbaum<sup>1\*</sup>, J. Read<sup>2</sup>, F. Meggers<sup>3,4</sup>

<sup>1</sup>Civil and Environmental Engineering, Princeton University, USA

<sup>2</sup>Waterloo Architecture, University of Waterloo, CAN

<sup>3</sup>School of Architecture, Princeton University, USA

<sup>4</sup>Andlinger Center for Energy and the Environment, Princeton University, USA

\*Corresponding author; e-mail: eteitlb@princeton.edu

#### Abstract

Mean radiant temperature accounts for roughly 50% of an occupant's level of perceived comfort, however building controls and HVAC complaints are typically centred on air temperature. With the proliferation and acceptance of radiant technologies, which heat and cool more effectively, as well as problems with radiant asymmetry in zoned air delivery systems, the need for radiant temperature information is increasing. Accurate radiant temperature measurements from industry standard black globe thermometers are dependent on precise understanding of convective air movements. Directional cameras are very expensive with limited field of view. Our research has developed a novel mean radiant temperature sensor, coupling cheap electronic components and geometric weighting algorithms to provide spatially resolved mean radiant temperature measurements for any point in a defined space. Specifically, a LIDAR range finder is coupled with precise servos and a narrow field of view radiant temperature sensor, which allow spherical coordinates of radiant temperature readings to be recorded. This approach to visualizing and measuring directionality of radiant temperature could directly impact building climate controls. The device has been used with our research to record the mean radiant temperature of an outdoor pavilion, where standard black globe thermometers were unsuccessful, as well as to spatially assess the mean radiant temperature in office spaces deemed uncomfortable by occupants. The results presented in this paper will pull from results of concurrent studies to provide calibration, comparison, and spatial data for the SMART Sensor, as well as the geometric justification of the data.

#### Keywords:

Mean Radiant Temperature; Sensors; Thermal Imaging; Arduino

### 1 INTRODUCTION AND MOTIVATION

The field of Building Physics in the United States and abroad is continuing to embrace and improve (1) radiant systems, (2) precision control algorithms, and (3) thermal comfort metrics. Many advances have been made in these fields in the past decades, however the primary mode of improvement is frequently on the research side, with many ingrained practices remaining unchanged and ripe for new technology development. From poor thermostat performance to overlooked urban comfort, we have addressed issues 1, 2 and 3 with a new device to provide

quick and inexpensive data on thermal conditions in our built environment. The system will not only enable increased comfort, but also help increase building heating and cooling performance, by far the largest part of the energy demand of a building helping to make buildings responsible for 40% of CO<sub>2</sub> emissions in the USA according to the US Department of Energy [1].

Our system is a non-contacting mean radiant temperature sensor, which is instrumental in addressing items 1, 2, and 3 above. Standard equipment for such measurements is often expensive, subject to heat loss due to convection

to air, and gives very little information aside from the overall mean radiant temperature [2]. Conventional approaches include black globe thermometers, technology that has been unchanged for nearly a century [2], or rely upon expensive instruments that have an extremely limited resolution [3,4]. Our SMART Sensor provides spatially resolved radiant temperature information, which is applicable to research, construction, and comfort controls domains. The SMART Sensor technology is not subject to heat losses or gains due to convection from wind or diffusers, making the technology universally deployable and more desirable than a black globe radiant temperature sensor, the industry standard. Such novel sensing allows for greater control capabilities for radiant exchange, for which there are many guidelines [5].

The SMART Sensor is an extension, combination and novel application of several technologies: a 5° field of view (FOV) Melexis radiant temperature sensor, a 2° FOV LIDAR Lite rangefinder, and two servos that swing the sensors through space in a spherical shell motion powered by a single microcontroller. At each point, temperature, distance, axial, and azimuthal readings are recorded. These values are then post-processed to provide information including air temperature, radiant temperature, and directional information. These are all essential for a true thermal comfort assessment or controls algorithm, but difficult to obtain with standard sensors. Additionally, as opposed to conduction and convection, which are superficially and volumetrically oriented processes; radiant heat transfer has a geometric component as well. For example, two occupants in the same room will not perceive the same mean radiant temperature, as they will experience surfaces and objects with different view factors. Therefore, the net energy balance with the inclusion of the radiant component, responsible for 50% of one's thermal comfort, cannot be precisely measured for an arbitrary number of locations in a room with one measurement. From spatial data obtained from the SMART sensor, the MRT can be approximated for any point in a room from a single measurement.

## 2 METHODS

The system development includes the device as well as the algorithms associated with post-processing of the data. The SMART sensor represents a novel implementation of components, a narrative behind placement and construction, and important algorithms for data processing.

### 2.1 Components

The SMART Sensor is controlled by an Arduino Yun microcontroller, which sends data via a serial communication to a receiver. This data can be

used in real time to visualize a space, or for further post processing by a user in a software such as Matlab. Images in this paper were created via this route. The Yun microcontroller was chosen as there is a built-in SD card slot, allowing data to be written to the SD card as well allowing for portable operation without computer assistance.

The servos deployed in the sensor's operation are manufactured by Parallax, and include a continuous rotation servo and a 180° servo. The continuous rotation servo is calibrated prior to use, determining the rotational velocity and using a timed control to provide a precise angular rotation. The 180° servo is simpler in operation, as its angular position is controlled by an internal mechanical system, with a program-specified angle. The azimuthal and rotational angles are calculated and reported to allow for plotting of the space in spherical coordinates. To calculate object distance, the SMART sensor has a LIDAR Lite module, is able to determine distances between 0-40m with accuracy of  $\pm 0.025\text{m}$  and can take up to 500 readings per second.

The infrared temperature sensor used is a Melexis MLX90614 5° FOV non-contacting temperature sensor. The accuracy of the sensor is  $\pm 0.5\text{ }^\circ\text{C}$  for an ambient temperature of 0-50  $^\circ\text{C}$  and object surface temperature of 0-60  $^\circ\text{C}$ . Within this range, accuracies are typically better with an accuracy of  $\pm 0.1\text{ }^\circ\text{C}$  from 20-30  $^\circ\text{C}$ , which includes the majority of temperatures in the building physics domain. When taking readings of the sky, accuracy goes down to  $\pm 1\text{ }^\circ\text{C}$ . The functional range of the sensor is -70 to 380  $^\circ\text{C}$ .

### 2.2 Data Processing

This data is recorded in a string and sent via serial as a 4-tuple as (distance, rotational angle, azimuthal angle, temperature). This allows data to be reproduced as a 3 dimensional representation, or with only temperature data as a spherical shell representing the net radiant heat flux through a spherical control volume around the sensor. Both approaches offer useful interpretations.

For the sensor, surface temperature is known for each point in a spherical mesh, with a desired weighted average of all readings. The problem is a simple geometric weighting transformation, which requires only knowledge of the mesh. By transforming to Cartesian coordinates first, a geometric weighting algorithm can compress each vertical column into a single data point, creating a line over which all values are equal which can then be averaged. In Fig. 1 below, this is accomplished for an image where the author's outline is clearly observed. The average from the top of Fig. 1 gives an MRT of 21.9  $^\circ\text{C}$ .

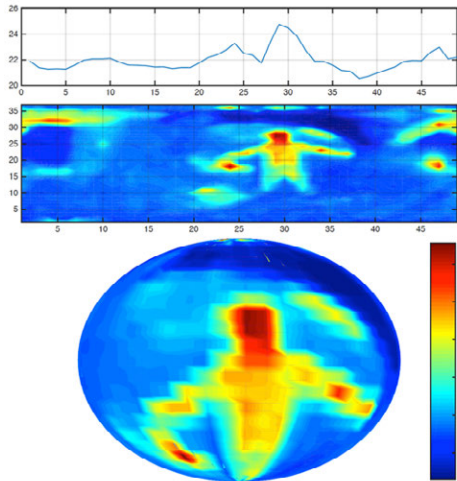

Fig. 1: Spherical information (bottom) Cartesian map (middle) to weighted distribution (top).

### 2.3 Case Studies

The sensor has been deployed in research by the Princeton C.H.A.O.S. Laboratory in campus and other experimental settings. There are many unique opportunities for such a novel sensor, and future studies will examine the capabilities and limitations of the sensor. This section contains brief descriptions of current applications of the sensor technology

#### Thermoheliodome

An experimental radiant cooling pavilion developed and built in summer 2014 by C.H.A.O.S. Lab, required a precise measurement of the MRT observed by an occupant at the focal point of the structure's geometry. The SMART sensor was developed for this application, as convective losses in an outdoor setting are large and inaccurately correlated with black globe thermometer readings. In fact, black globe thermometer readings were imprecise and noisy. Data was recorded and used in conjunction with air temperature to calculate the operative temperature inside the space, which informed calculations regarding performance of the structure compared to other cooling technologies.

#### Office Assessments

A case study was performed in the Princeton University School of Architecture, where comfort complaints were investigated using an air temperature sensor as well as the SMART sensor. Results were not scientifically analysed, however were able to be used to inform solutions, such as when a thermostat setpoint change was necessitated versus window shading or duct configuration changes.

#### Comparison to IR cameras

Additionally, the SMART sensor was compared to top of the line high FOV infrared imaging cameras. While the two sensors are in two different domains as far as imaging and analysis, the two were compared to demonstrate the trade-off between resolution and spatial data with regard to thermal comfort.

## 3 RESULTS

Initial prototyping and calibration has led to a successful prototype operation and a patent disclosure. Fig. 2 shows a prototype of the SMART sensor, equipped with LIDAR Lite and an infrared non-contacting temperature sensor. The binocular-like portion is the LIDAR Lite element, and the smaller cylinder underneath is the 5° FOV non-contacting temperature sensor. They are held tightly in place with adequate separation as to not interfere. The rigid construction ensures reproducible results.

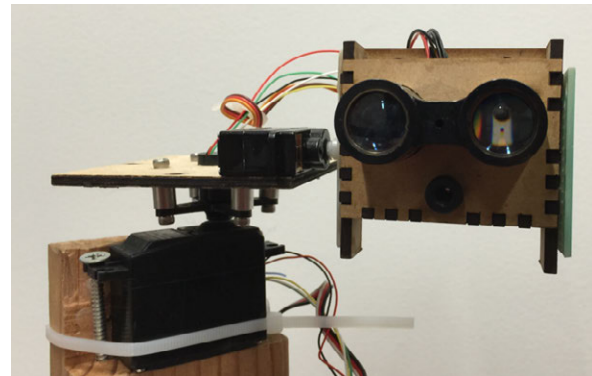

Fig. 2: SMART Sensor prototype.

### 3.1 Thermoheliodome

As mentioned in the methodology, the SMART sensor was initially developed to measure MRT in outdoor cooling pavilions. In this scenario, insensitivity to convection is essential. The sensor was able to produce reliable measurements, and produce a 3D point cloud of the Thermoheliodome (Fig 3c). The values were particularly enlightening because the site was adjacent to a building, and the MRT measured inside was clearly influenced by a warm wall on the adjacent building. The warm temperatures shown in Fig. 3b are caused by this wall. While the MRT data was taken from an earlier sensor prototype than the one described in this paper, it was spatial information from the SMART sensor that fully described how the difference between air temperature and MRT was created by the wall outside of the pavilion.

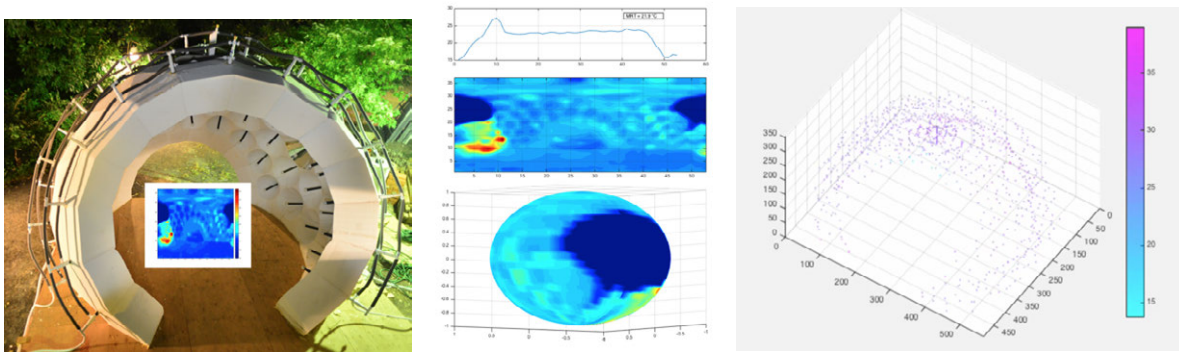

Fig. 3a-c: a (left) – Photo of sensor data in a dome-shaped radiant cooling pavilion; b (middle) – Temperature data plotted and weighted to provide radiant temperature, compared with air temperature; c (right) – A spatially resolved image of the pavilion with locations represented in colour corresponding to the temperature reading.

The spatial information provides a strong understanding of view factors, shading, and important surface temperatures. In the case of the Thermoheliodome, the data suggests repositioning the dome such to avoid incident re-radiation from the adjacent heated wall. While the sensitivity of the dome's geometry relative to the sun path prohibits this, the information is instructive nonetheless.

### 3.2 Office Assessments

This experiment was used as a demonstration of the utility of the SMART Sensor. Thermal maps of offices were examined and occupants were informed of any changes in behaviour or system controls that were informed by the images.

Fig. 4 shows an image taken from the Princeton University School of Architecture IT office. Warm regions increase the MRT of an occupant seated at the main desk to 28.9 °C. The air temperature is also high, 28 °C, implying an air side issue, rather than only a radiant component to the comfort complaint. In fact, this evidence prompted contacting building facilities, where it was learned that a cooling coil was broken at the time of the study.

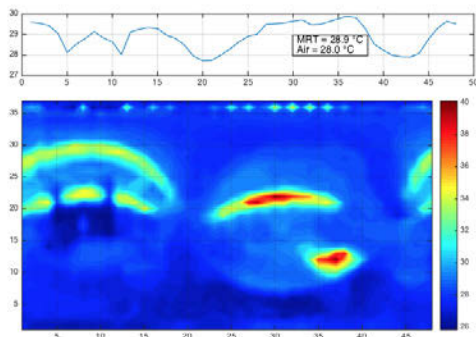

Fig. 4: Server room and IT Office.

Fig. 5 shows an exterior office on the ground level, with a large window with poorly sealed operable symmetric window panels on either side, shown in the middle of the figure. The MRT in this space is 20.6 °C, compared to a

comfortable air temperature of 21.5 °C. This data implies comfort could be improved by installing shutters to reduce the amount of cold surface area in the space. Increasing the air temperature is not possible, as there are other rooms controlled by the same setpoint in the hall that would become overheated.

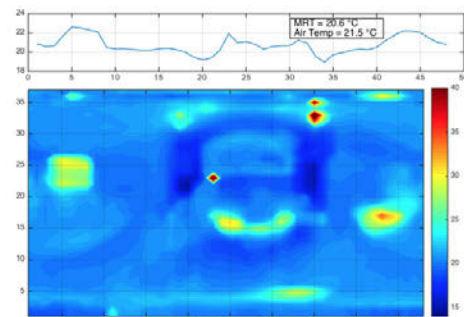

Fig. 5: Exterior Ground Floor Office.

### 3.3 Comparison to IR Camera

Information from our sensor was also compared to a high-resolution thermal camera, the E60 manufactured by FLIR, with a 45° wide angle lens. The purpose of FLIR's camera is primarily diagnostics and other documentation, as well as detailed non-contacting temperature profiles. As far as resolution, the E60 is far superior. However, while the E60 gives detailed information per particular views, even a 45° FOV lens represents a small fraction of the space's surface area when viewed from the same point as the SMART sensor is set up. Compared to a 90° FOV, representing approximately one octant, a 45° FOV image from the same point in space will only contain 17% of the overall surface area. Therefore, assuming there are 8 octants making up the SMART sensor's image, 46 non-overlapping images would be required to reproduce the SMART sensor's image with the E60. In reality, this is the worst-case scenario, as there are many geometric ways to reduce this number. This comparison is still instructive.



Additionally, from one revolution of the SMART sensor, mean radiant temperature data can theoretically be calculated for each point in the space since the room is plotted in a 3D geometry. The E60 or similar cameras would be limited to a spherical approach (i.e. Fig. 3b rather than Fig. 3c) Even in this scenario, splicing photos together to create a sphere (i.e. going from a

Cartesian map to a spherical globe) is difficult since edges are poorly defined compared to standard visual spectrum images used in splicing applications. As the Melexis sensor values compare well to a calibrated FLIR E60 as shown in Fig. 6, the authors believe the SMART sensor is the best way to obtain mean radiant temperature information.

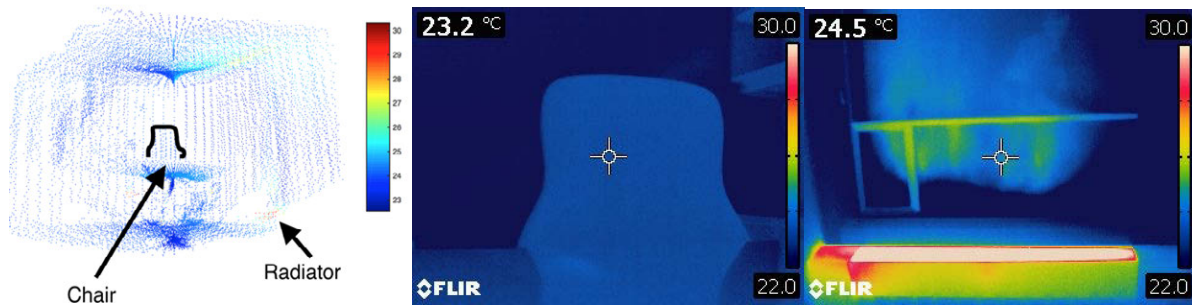

Fig. 6: SMART Sensor point cloud (left) with components shown in comparison to images of the same features from a FLIR E60 (middle and right).

#### 4 DISCUSSION

There is a vast application potential across the thermodynamics research and building physics domain. The system is borne from the Internet of Things (IoT) revolution, which seems to self-catalyse novel sensing devices. The NEST thermostat for instance is a novel device in which users set comfort levels remotely from their house, maximizing comfort and minimizing energy use and costs, but still depending on single air-temperature sensing alone. Our system would allow a radiant component of thermostat controls, which would allow for even greater savings with technologies similar to the NEST. Large companies such as Honeywell are currently embracing the Industrial IoT and using 3D modelling technology to enhance user experiences. The SMART sensor fits with this motif.

Aside from the Internet of Things hype, thermal imaging manufacturers have been extending the infrared imaging market to standard consumers, by making more affordable products that connect to smart-phones, or producing other standalone pocket-sized peripherals. Our system fits squarely in this new field, and is a prime example of the expansions of available information to improve building controls and performance. A typical thermal camera costs upwards of USD \$1000, largely due to the expensive glass to filter visible light and allow IR through. The expensive glass in turn also limits the field of view because making wide-angle lenses like fisheye lenses is not economically feasible. Our system solves this in an inexpensive manner by panning a \$35 single sensor around a space and reconstructing the full surface digitally.

A single sensor is promising, but a set of sensors may be the long-term solution in terms of producing the surface temperature map of a

space. For instance, in a building controls application, it may not be pertinent to introduce a moving part to perform such a central operation. Therefore, the SMART sensor in its current iteration may be limited to a one-time building controls calibration use, whereas an implementation with a set of fixed sensors may be the permanent solution. However, the novelty of having MRT data for each point in a space is a hugely useful starting point from a radiant system controls standpoint.

#### 5 CONCLUSIONS AND FUTURE WORK

Future research includes producing a more compact, watertight enclosure and allow for more research and work to be performed on the post-processing of the data. The end goal would be a sleek, compact product that comes with an application package that seamlessly allows analysis of any space. New rapid prototyping systems for small scale milling of parts and PCBs and 3D printing will be acquired along with a larger set of sensors to test and deploy the device. Additionally, research as part of a larger controls project informed by data from a SMART sensor would be a promising area.

#### 6 REFERENCES

1. U.S. Department of Energy (DOE), "2011 Buildings Energy Data Book" Prepared for the DOE Office of Energy Efficiency and Renewable Energy by D&R International, 2011.
2. Spagnolo, Jennifer, and Richard De Dear. "A field study of thermal comfort in outdoor and semi-outdoor environments in subtropical Sydney Australia." *Building and environment* 38.5 (2003): 721-738.
3. Thorsson, Sofia, et al. "Different methods for estimating the mean radiant temperature in an

outdoor urban setting." *International Journal of Climatology* 27.14 (2007): 1983-1993.

4. Höpfe P. 1992. A new procedure to determine the mean radianttemperature outdoors. *Wetter und Leben* 44: 147–151.

5. Wessel, D. J. "Ashrae fundamentals handbook 2001 (si edition)." *American Society of Heating, Refrigerating, and Air-Conditioning Engineers* 31 (2001).



## Expanding Boundaries: Systems Thinking for the Built Environment

### ENVIRONMENTAL OPTIMISATION OF SHOTCRETE APPLIED AT THE BRENNER BASE TUNNEL (BBT)

T. Cordes<sup>1\*</sup>, F. Gschösser<sup>2,3</sup>, K. Bergmeister<sup>1</sup>

<sup>1</sup> Brenner Base Tunnel BBT-SE, Amraser Straße 8, A-6020 Innsbruck, Austria,

<sup>2</sup> Leopold-Franzens University of Innsbruck, Unit for Project and Construction Management, Technikerstraße 13, A-6020 Innsbruck, Austria

<sup>3</sup> floGeco – Environmental Management, Hinteranger 61d, A-6161 Natters, Austria

\*Corresponding author; e-mail: tobias.cordes@bbts-se.com

#### Abstract

For the construction of the access tunnel “Wolf” of the Brenner Base Tunnel (BBT), ecologically optimized shotcrete is applied in order to reduce the environmental impacts of the tunnel. Therefore shotcrete mixtures with aggregates consisting of 100% processed tunnel spoil and cements with lower clinker content were developed considering all project requirements.

The following LCA (Life Cycle Assessment) study evaluates the environmental improvements achieved by the applied optimized shotcrete. Therefore, the study compares four recipes of shotcrete:

- (i) with processed tunnel spoil (100 %) and Portland cement (CEM I)
- (ii) with processed tunnel spoil (100 %), composite (CEM II/A-M) and Portland cement (CEM I) as well
- (iii) with primary aggregates (100 %) and Portland cement (CEM I)
- (iv) with primary aggregates (100 %) and composite cement (CEM II/A-M)

The environmental indicators applied for the LCA are Global Warming Potential (GWP), Acidification Potential (AP) and Non-renewable Cumulative Energy Demand (Nr-CED). The Mineral Resource Demand (MRD), which is part of the Swiss Ecological Scarcity Method, is used to describe the impact of tunnel spoil recycling.

The results of the study show that the application of optimized shotcrete at the BBT conserves a considerable amount of mineral resources (MRD) and furthermore reduces environmental pollution (GWP, AP, Nr-CED) although not at the same level as for mineral resources. These lower reductions can be explained by an increased content of fines in the processed aggregates grading curve, what demands higher water and consequently higher cement content. Furthermore, the study demonstrates that the production of raw materials is of significant importance for all four indicators. Raw material transport and concrete production (mixing) processes play a minor role regarding the LCA results.

#### Keywords:

LCA; shotcrete; Tunnel, Spoil; Bündner schist; Mineral resource demand; Global Warming Potential; Acidification Potential; Non-renewable Cumulative Energy Demand

## 1 INTRODUCTION

The Brenner Base Tunnel (BBT) is the heart of the Scandinavia-Mediterranean TEN Corridor from Helsinki (Finland) to La Valletta (Malta). The Tunnel is a straight, flat railway tunnel of 55 kilometres length, crossing the central Alps

between Innsbruck (Austria) and Fortezza (Italy). Approximately 5 million cubic meters of different types of concrete will be required for this rail connection and 15.5 million cubic meters of spoil will be excavated. In order to dispose as little spoil as possible in landfills, a primary objective is the recycling of a great part of the spoil as filler,

drainage gravel as well as solid and loose foundation layers. The main interest regarding the recycling of spoil is of course its re-use as aggregates for concrete production.

In this study the environmental improvements for shotcrete applied at the access tunnel of BBT-site "Wolf" (Austria) are presented, i.e. shotcrete with aggregates consisting of 100 % spoil and optimized cements with lower clinker content.

## 2 PROCESSED TUNNEL SPOIL

The tunnel alignment of the BBT crosses four main lithologies: Innsbruck quartz phyllite, Bündner schist, central gneiss and Brixen granite. Central gneiss and Brixen granite are advantageous lithologies for all kind of re-use. The Innsbruck quartz phyllite is poorly suitable for the reuse as processed aggregates [1]. For the Bündner schist feasibility studies [1,2] show the opportunity to process and reuse the tunnel spoil within shotcrete. Hence, in order to reduce the landfill volume and to increase the sustainability of the overall project a specific material management including concepts for material flows, processing and quality control was developed [3]. From an economic point of view it was determined that the reuse of the tunnel spoil is very beneficial for long tunnels. However, the necessary length of the tunnel to finally amortize the investment into spoil processing depends on the particular lithology.

For the access tunnel of the BBT-site Wolf the processing of tunnel spoil consisting mainly of Bündner schist lithology is carried out in several process steps. The spoil passes through a pre-crushing process with dry screening followed by the processing plant with two additional crushing units and wet screening before finally getting to a bucket-wheel sand washing plant. So far, after some adaptations of the processing plant at the beginning all applied concrete aggregates on the BBT-site Wolf have been processed out of tunnel spoil.

## 3 SHOTCRETE MIXTURE

The key materials in tunnel construction are shotcrete and concrete. According to the World Resources Institute [4] the worldwide cement industry accounts for 3.8 % of the total greenhouse gas emissions or around 5 % of the global CO<sub>2</sub> emissions. Most of the CO<sub>2</sub> emission during concrete production is caused by limestone decarbonation occurring during the clinkering process. Thus, the reduction of the clinker content within the concrete also reduces its environmental impacts. A clinker substitution is done by Portland composite cements (e.g. CEMII or CEM III) and to some extent by substitutions with less energy- and CO<sub>2</sub>-intensive latent hydraulic additions.

At BBT-site Wolf different variants of cements and hardening accelerators were tested within the shotcrete mixtures. For two of these shotcretes mixtures (OSc1 and OSc2 – Table 1), a Life Cycle Assessment (LCA) was carried out. The results were compared to the LCA results of two standard shotcrete recipes (SSc1 and SSc2 – Table 1).

	Standard shotcrete		Optimized shotcrete	
	SSc1	SSc2	OSc1	OSc2
	kg/m <sup>3</sup>	kg/m <sup>3</sup>	kg/m <sup>3</sup>	kg/m <sup>3</sup>
Cement				
CEM I 52,5 R	400		208	320
CEMII/A-M 42,5R		360	208	
Additives				
Latent Hydraulic Add.	20	60	49	100
Water	200	200	219	216
Aggregates				
Primary agg.	1650	1819		
Processed spoil			1607	1607
Admixtures				
Hardening acc.	24	21,6	24	24

Table 1: Investigated shotcrete mixtures.

Table 1 demonstrates the higher water demand caused by the higher content of fines in the processed aggregates grading curve compared to the standard grading curve.

## 4 LCA

The environmental improvements achieved by the optimized shotcrete used applied for the access tunnel of the BBT-site Wolf are analysed using the Life Cycle Assessment (LCA) method according ISO 14040 [5] and ISO 14044 [6] The LCA was carried out with nine indicators, four environmental indicators and five indicators for the consumption of resources. The results for the following four key indicators will be presented in this study:

- (i) Global Warming Potential (GWP),
- (ii) Acidification Potential (AP),
- (iii) Non-renewable Cumulative Energy Demand (Nr-CED) and
- (iv) Mineral Resource Demand (MRD) from the Swiss Ecological Scarcity Method.

The investigated shotcretes are similar in terms of strength and durability and are mixed on site. Thus, for all investigated shotcretes except from the disposal phase (C4) all life cycle phases after the mixing process (A4 – C3) can be defined as equal and not significant for the study. However, the fact that the reused spoil does not need to be landfilled (C4) for the optimized shotcretes is

taken into account as burden for the standard shotcrete mixtures.

Thus in accordance with EN 15804 [7] the system boundaries for the LCA study were set as shown in Fig. 1.

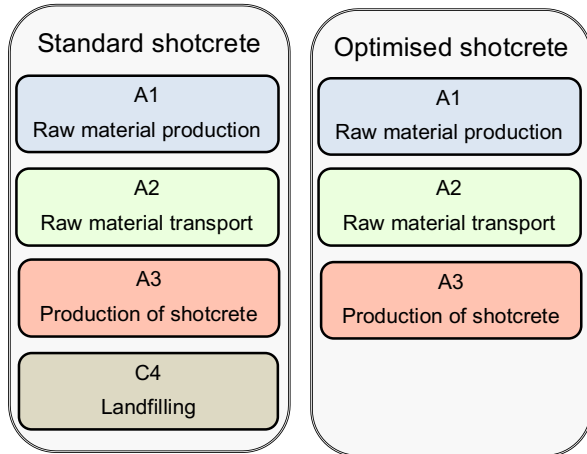

Fig. 1: System boundaries of the LCA study.

All the processes from the extraction of raw materials to the finished production of the shotcrete mixture are considered, i.e. a "from cradle to gate" LCA is carried out. Therefore, no analysis period respectively product lifetime is considered. The comparison is made for a functional unit of '1 m<sup>3</sup> of shotcrete used for the access tunnel support'.

The life cycle inventory datasets were modelled with SimaPro using the database ecoinvent 2.2. For the raw material production (Fig. 1; A1) the required materials according to Table 1 are considered. In addition the influences of air-entraining agents, stabilizer and plasticizer are modelled, but however their impact is insignificant. Thus, their environmental impacts are summed up in the results as 'admixture other'.

For cement production, tap-water use, primary aggregates (gravel crushed), plasticizer and air-entraining agent the Swiss ecoinvent datasets were adopted according to the electricity mix for Austria.

The mixture of latent hydraulic additions is standardised within ÖN B 3309-1 [8]. For this study the secondary raw material within the latent hydraulic additions is considered by applying the economic allocation method.

## 5 RESULTS

Fig. 2 shows the results for the Mineral Resource Demand (MRD). The significant differences between the results for the shotcretes with and without primary aggregates underline the need of saving resources by reusing processed tunnel spoil.

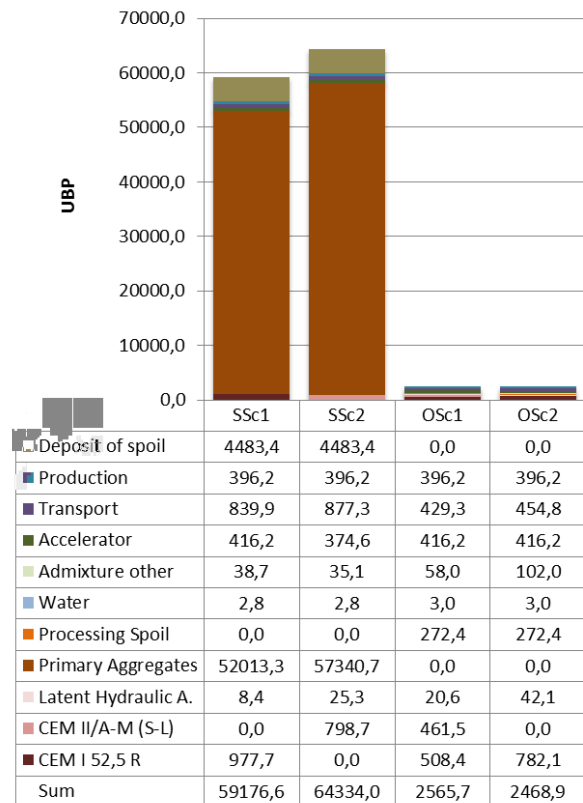

Fig. 2: Comparison of mineral resources (EP).

Fig. 3 compares the GWP in kg CO<sub>2</sub> equivalents and shows the main influence of the cement and a minor influence of production and transport. The acidification potential in SO<sub>2</sub> equivalents is demonstrated in Fig. 4. The results generally correspond with the GWP-results, but with a lower influence from the cements and a higher influence from accelerator production, disposal of spoil and from transport processes. For the Non-renewable Cumulative Energy Demand an even higher influence from these three processes is recognised (Fig. 5).

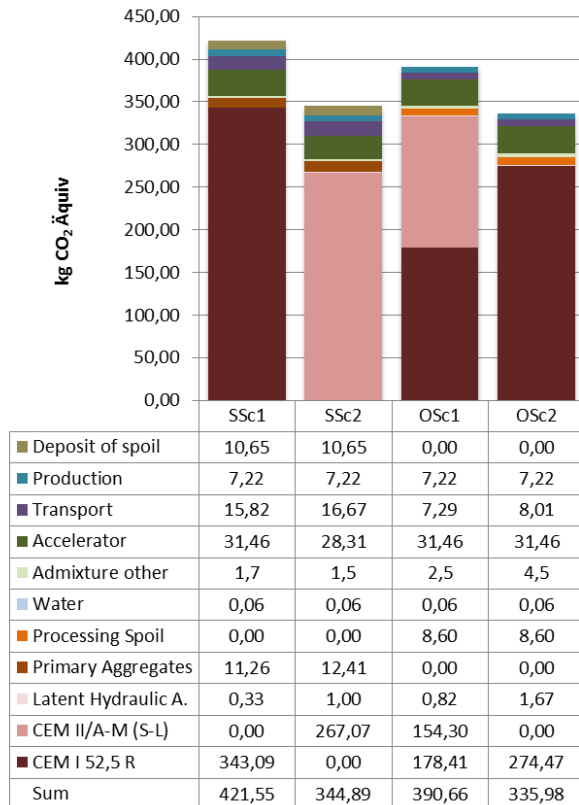

Fig. 3: Comparison of GWP (Global Warming Potential) [kg CO<sub>2</sub> eq].

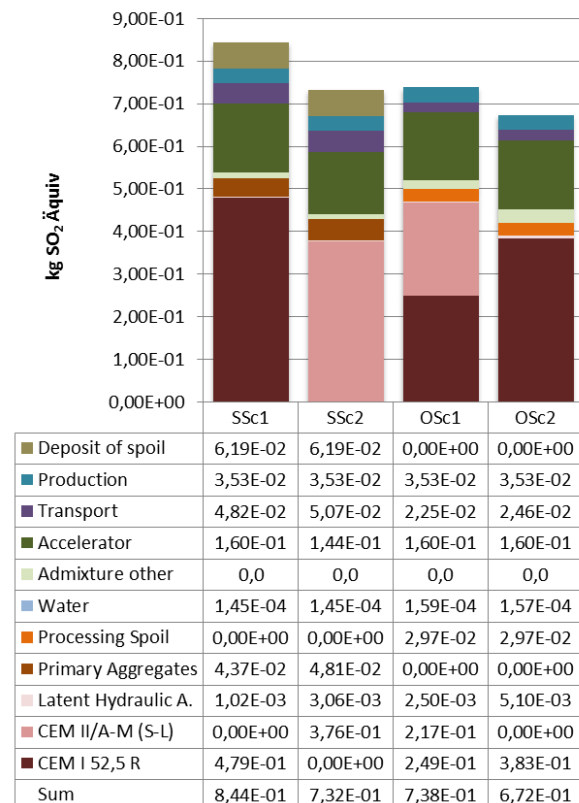

Fig. 4: Comparison of the AP (Acidification Potential) [equivalent kg of SO<sub>2</sub> eq].

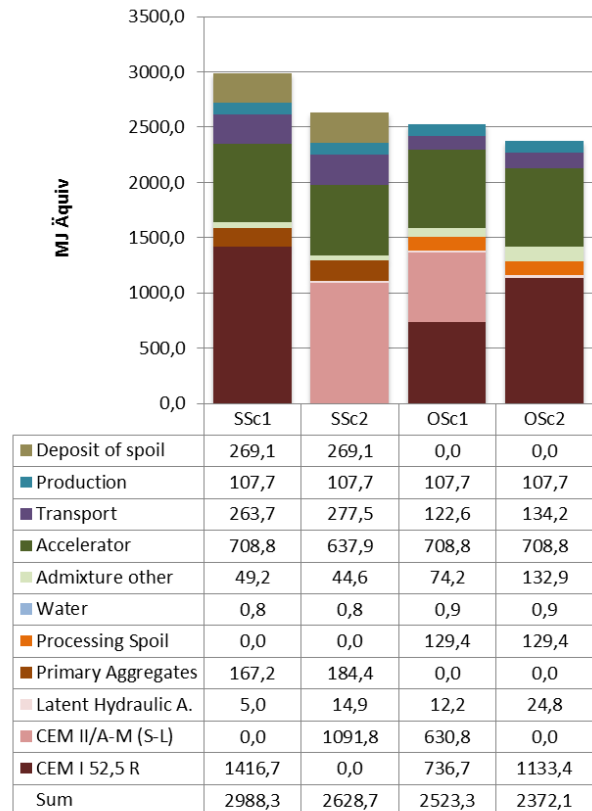

Fig. 5: Comparison of the nr-CED (Non-renewable Cumulative Energy Demand) [equivalent MJ eq].

## 6 SUMMARY

The Ecological Scarcity Method is based on Swiss environmental policies in which conservation of mineral resources such as gravel and sand plays an important role.

This emphasizes the need for the construction sector and especially for large construction projects such as the Brenner Base Tunnel to apply recycling material wherever possible and reasonable, to save important resource and to reduce the disposal processes.

The use of tunnel spoil also has a positive effect on the results for the other main indicators, although not at the same level as for mineral resources. This can be explained by the higher cement demand for the shotcretes with tunnel spoil, which slightly diminishes the positive effect of spoil application.

The analysis also shows that the production of raw materials (especially clinker for cements) are extremely important for all four indicators and that transport and concrete production processes play a subordinate role.

## 7 OUTLOOK

For the GWP, AP and Nr-CED indicators further reductions can be achieved by optimizing the cement respectively reducing its clinker content. This reduction is limited due to required concrete characteristics and the necessary early strength development (class J2).

## 8 ACKNOWLEDGMENTS

This study is co-financed by the European Union.

## 9 REFERENCES

1. Voit, K. Einsatz und Optimierung von Tunnelausbruchsmaterial des Brenner Basistunnels, Phd-Thesis 2013, University of Natural Resources and Life Sciences, Vienna
2. Arnold, R., et al., Gewinnung von Gesteinskörnungen aus Bündner Schiefer für Innenschalenbeton beim Brenner Basistunnel, bauaktuell 9/2015, Linde Verlag
3. Voit K., Zeman O.; Murr R., Arnold R., Bergmeister K.: *Aufbereitung und Wiederverwertung von Tunnel Ausbruchmaterial beim Brenner Basistunnel*. Beton- und Stahlbetonbau. 2015-12. Ernst & Sohn, Berlin Germany
4. *Navigating the numbers*. Greenhouse Gas Data and Int. Climate Policy, World Resources Institute 2005
5. ISO, *ISO 14040:2006 - Environmental management - Life cycle assessment - Principles and framework*. 2006, International Standard Office: Geneva
6. ISO, *ISO 14044 - Environmental management - Life cycle assessment - Requirements and guidelines*. 2006, International Standard Office: Geneva.
7. ÖNorm EN 15804: 2014 Sustainability of construction works — Environmental product declarations — Core rules for the product category of construction products. 2014-04-15 Austrian Standards Institute
8. ÖN B3309-1: 2010 Processed hydraulic additions for concrete production - Part 1: Combination products (GC/GC-HS). 2010-12-01 Austrian Standards Institute







## Expanding Boundaries: Systems Thinking for the Built Environment

### MATERIAL QUANTITIES AND EMBODIED CARBON IN EXEMPLARY LOW-CARBON CASE STUDIES

C. De Wolf<sup>1\*</sup>, K. Bird<sup>2</sup>, J. Ochsendorf<sup>1</sup>

<sup>1</sup> MIT, 77 Massachusetts Ave, Cambridge, MA 02139, USA

<sup>2</sup> Helionix Designs, Pines Garden, Beach Road, St Margaret's Bay, Dover, Kent CT15 6DZ, UK

\*Corresponding author; e-mail: cdewolf@mit.edu

#### Abstract

Whole life cycle emissions include not only *operational* carbon due to the use phase of the building, but also *embodied* carbon due to the rest of its lifecycle: material extraction, transport to the site, construction and demolition. The aim of this research is to extend the work on embodied carbon from the material scale to the structural scale. Therefore, a methodology has been developed to estimate the embodied carbon of an entire building structure based on the Structural Material Quantities (kg/m<sup>2</sup>) and the Embodied Carbon Coefficients (kg<sub>CO<sub>2e</sub></sub>/kg). The collected data focuses mainly on structural materials, as more than half the material mass goes into the structure of buildings. The two main contributions of this paper are the quantification of embodied carbon in case studies and the comparison with a range of 260 existing buildings worldwide. The case studies are the rammed earth and tile vaulting applied in the Pines Calyx (United Kingdom) and the funicular vaulting and structural ribs applied in the HiLo Nest building (Switzerland). The case studies range between 100 and 200 kg<sub>CO<sub>2e</sub></sub>/m<sup>2</sup>, more than two to four times lower than the average result obtained in collaboration with industry. In conclusion, this research offers a transparent methodology to evaluate the embodied carbon of different structural designs.

#### Keywords:

Embodied Carbon; Material Quantities; Global Warming Potential

## 1 INTRODUCTION

Life cycle energy in buildings includes operational energy for heating, cooling, hot water, ventilation, lighting on one hand and embodied energy for material supply, production, transport, construction and disassembly on the other. The synonymous terms “embodied carbon” and “Global Warming Potential” (GWP) describe all lifecycle greenhouse gas (GHG) emissions by their equivalent quantities of carbon dioxide (CO<sub>2e</sub>). The other GHGs such as CH<sub>4</sub>, N<sub>2</sub>O, SF<sub>6</sub>, PFC and HFC can hence be converted to CO<sub>2</sub> using conversion factors in order to obtain a common unit for the environmental impact [1], i.e. the “carbon dioxide equivalent”.

Many leading structural engineering and design firms are currently developing in-house embodied carbon estimators to answer the following question: what is the embodied carbon for different structures? A multitude of tools were

developed in the last few decades to evaluate the environmental impact of the building sector. Life Cycle Assessment (LCA) tools can be used on the material scale and Material Flow Analysis (MFA) tools on the city scale. On the building scale, energy simulation tools only focus on operational energy. However, if the whole life cycle of the building is taken into account, it is important to look at the embodied energy as well.

This paper looks at embodied carbon rather than embodied energy, as this research aims to measure the contribution to climate change and quantifying specifically in carbon equivalent helps to compare the embodied with operational emissions. The same amount of embodied energy can emit different intensities of GHGs depending on the energy mix used and the carbon emitted or absorbed by the materials processed. For example, emissions occur in the

chemical processing of cement, whereas carbon is sequestered in wood.

There is no consensus for embodied carbon assessment methods of buildings. Recent innovations have helped reduce the operational carbon, but a lack of benchmarking and literacy hinders the reduction of embodied carbon. Moreover, the Intergovernmental Panel on Climate Change [1] warns that carbon reduction is needed in the next decade if we want to avoid extreme climate catastrophes. With on-going population growth, and consequentially the increasing demand for buildings, reducing embodied carbon is imperative. Indeed, embodied carbon emissions are immediate and irreversible, unlike operational carbon, which can be minimised through energy efficiency measures. Furthermore, research in this field will help structural engineers and architects to understand how to lower embodied carbon and fill this gap in literature [2]. Finally, rating schemes such as LEED [3] and BREEAM [4] have begun including embodied carbon in their credit systems, though without defining baselines for benchmarking [5].

It should be noted that this paper is limited to structural material quantities. Cladding and other non-structural materials are not considered for three reasons. Firstly, this research aims to include structural engineers in the conversation about the environmental impact of buildings. Secondly, the structural components account for the greatest mass in buildings and contribute to roughly half of the total carbon emissions due to materials [6]. With a breakdown of embodied carbon for the different elements in offices, hospitals and schools, Kaethner and Burridge [7] demonstrate that the super- and substructure together represent more than 50% of the total embodied carbon emissions of buildings (Fig. 1). Thirdly, this helps to focus attention within well-defined parameters while still having a significant impact.

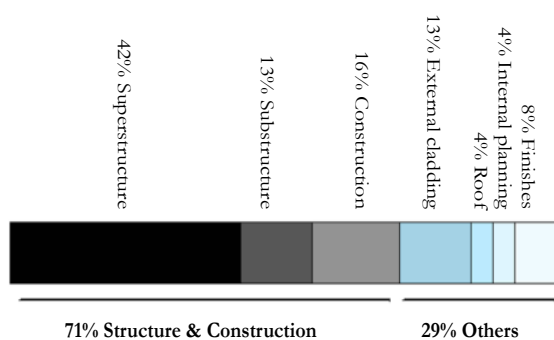

Fig. 1: Average breakdown in building elements of embodied carbon, after (Kaethner and Burridge, 2012).

## 2 PROBLEM STATEMENT

To develop a methodology for estimating embodied carbon on the building scale, two case studies are analysed: the Pines Calyx in St Margaret's Bay, Dover, United Kingdom, and the HiLo Nest project in Zurich, Switzerland. This work answers two key questions:

- What is the embodied carbon of low carbon structural designs?
- How do they compare to other building structures?

With the useable floor area as a functional unit, the GWP is measured in  $\text{kg}_{\text{CO}_2\text{e}}/\text{m}^2$ . Two key variables are needed: Structural Material Quantities (SMQ), expressed in kg of material ( $\text{kg}_{\text{material}}$  or  $\text{kg}_m$ ) per functional unit (often  $\text{m}^2$ ), and Embodied Carbon Coefficients (ECC), expressed in kg of  $\text{CO}_2$  equivalent ( $\text{kg}_{\text{CO}_2\text{e}}$ ) per kg of material ( $\text{kg}_m$ ). Presently, there is no clear standard for accurate ECC values and information on SMQ values for buildings is scarce.

As illustrated in equation 1, the GWP ( $\text{kg}_{\text{CO}_2\text{e}}/\text{m}^2$ ) is obtained by multiplying the two key variables: the material quantities in  $\text{kg}/\text{m}^2$  with the ECCs, while taking waste or breakage into account. To calculate the total embodied carbon (total GWP), cradle-to-grave ECCs should be used. If we are only looking at the material embodied carbon ( $C_m$ ), the cradle-to-gate ECCs can be used. These can be found in databases such as the Inventory of Carbon and Energy (ICE) database from the University of Bath.

$$\text{GWP} = \sum_{i=1}^n \text{SMQ}_i \left(1 + \frac{w_i}{100}\right) \text{ECC}_i \quad (1)$$

where:

GWP	Global Warming Potential ( $\text{kg}_{\text{CO}_2\text{e}}/\text{m}^2$ )
$\text{SMQ}_i$	Structural Material Quantities ( $\text{kg}_m/\text{m}^2$ )
$w_i$	Waste (%)
$\text{ECC}_i$	Embodied Carbon Coefficients ( $\text{kg}_{\text{CO}_2\text{e}}/\text{kg}_m$ )

## 3 LITERATURE

Simonen [8] and Moncaster and Symons [9] highlight the general lack of data in the field of embodied carbon. Various reports have analysed the environmental impact of concrete [10, 11, 12], as well as the impact of cement [13]. Other articles describe the embodied energy of metals [14] and in particular steel [15, 16, 17, 18]. Next to concrete and steel, the embodied energy of other construction materials such as timber has been discussed [19]. However, there is a significant variability in the ECC values for all materials.

The ICE report from the University of Bath summarizes ECC values for most construction materials [20]. The ICE report selects the best available embodied energy and carbon data. However, there is still a need for values for each

country or region. The Carbon Working Group [6] also discusses the embodied carbon of common construction materials. They discuss the uncertainty of carbon footprints, data quality and variability. As different sources might not use the same assumptions, the Carbon Working Group identifies a need for a more reliable and comparable definition of ECC values. Several LCI and LCA tools exist to calculate impacts of single projects or materials. The commercial LCA software Gabi [21] and SimaPro [22] can perform an LCA of a unit of construction materials to estimate the ECC values. These commercial tools are common practice for LCA calculations, but their data are proprietary. Also, EcoInvent [23] provides thousands of LCI datasets for various applications from agriculture to electronics. OpenLCA [24] is an open source software that helps users perform LCAs of buildings.

The Athena Institute is a non-profit organization based in Canada that has integrated LCI data into building industry specific tools: the Athena Eco Calculator (free) and the Athena Impact Estimator [25]. Various companies have developed in-house tools focused on estimating the embodied carbon of their projects. Kieran Timberlake and PE International recently released the TALLY tool [26], which extracts data from Revit models. The SOM Environmental Analysis tool is a user-friendly embodied carbon calculator for design projects [27]. In the United Kingdom, the non-profit Waste Reduction Action Program (WRAP) developed a project-based database of embodied carbon [28]. WRAP asks users of the web-interface to clearly mark building life cycle stages and to reference the used LCA software, without asking specifically for material quantities. Many leading structural engineering firms have started an in-house database of structural material quantities or embodied carbon of their own projects. One thoroughly developed example is the Arup Project Embodied Carbon and Energy (PECD) mainly consisting of Arup buildings and projects from literature [29]. Although PECD contains approximately 600 projects, it does not yet allow the definition of a baseline due to the data scarcity and their wide ranges. Other companies such as Thornton Tomasetti have also developed a database of the material quantities, extracted via a Revit plug-in, and the embodied carbon of their projects.

This paper applies the available data on the ECCs of construction materials and SMQs in existing and newly developed databases in order to illustrate methodologies for lower embodied carbon buildings.

## 4 MATERIALS AND METHODS

### 4.1 Total embodied carbon

The total embodied carbon is the summation of the embodied carbon attributed to the production, construction, maintenance, and end-of-life stages. The first step of calculations (and often the main contribution to the embodied carbon) is for the production and construction stages. This is calculated in three parts: the embodied carbon of the materials themselves, the carbon emissions due to the transportation of the materials to the site and the carbon emitted during the building erection. The following equations are based on Vukotic et al. [30] and Moncaster and Symons [9].

There is no reliable database for cradle-to-grave ECCs, so that the calculation process described below is required. The overarching equation to calculate the total embodied carbon of the building is given by equation 2.

$$EC_{\text{whole life}} = \sum_{i=1}^n EC_{\text{prod/constr},i} + \sum_{i=1}^n EC_{\text{re},i} + EC_{\text{eol}} \quad (2)$$

where:

$\sum_{i=1}^n EC_{\text{prod},i}$  is the embodied carbon of the product and construction process stage, including raw material supply, transport, manufacturing, the transport from manufacturer to the site, the construction-installation process;

$\sum_{i=1}^n EC_{\text{re},i}$  is the embodied carbon of the use stages corresponding to repair, refurbishment and replacement;

$EC_{\text{eol}}$  is the end-of-life stage embodied carbon, including de-construction/demolition, transport, waste processing and disposal.

### 4.2 Product and construction

The first term looks at the product and construction with equation 3.

$$\sum_{i=1}^n EC_{\text{prod/constr},i} = \sum_{i=1}^n EC_{\text{prod},i} + \sum_{i=1}^n EC_{\text{transp},i} + EC_{\text{constr}} \quad (3)$$

where:

$\sum_{i=1}^n EC_{\text{prod},i}$  is the material embodied carbon;

$\sum_{i=1}^n EC_{\text{transp},i}$  are the carbon emissions due to transporting the material from the manufacturer to the site;

$EC_{\text{constr}}$  is the carbon emitted during the building erection.

The first part of equation 3, the material embodied carbon, is calculated similar to equation 1, where the material quantities (kg) are multiplied with the cradle-to-gate ECCs, allowing to take waste or breakage into account.

$$\sum_{i=1}^n EC_{\text{prod},i} = \sum_{i=1}^n SMQ_i \left(1 + \frac{w_i}{100}\right) ECC_{i, \text{cradle-to-gate}} \quad (4)$$

where:

$SMQ_i$  are the Structural Material Quantities (kg<sub>m</sub>);

$w_i$  is the waste (%)

$ECC_{i, \text{cradle-to-gate}}$  are the cradle-to-gate Embodied Carbon Coefficients (kg<sub>CO2e</sub>/kg<sub>m</sub>)

The next part of the calculation looks at the material transportation and its carbon emissions. This is illustrated in equation 5, where for each

material the number of truckloads is multiplied with twice the distance travelled from manufacturer to the site and with the fuel consumption in litre per kilometre as well as the fuel combustion emissions in kilograms of CO<sub>2e</sub> per litre.

$$\sum_{i=1}^n EC_{\text{transp},i} = \sum_{i=1}^n t_i \times 2d_i \times fc_i \times fCO_{2i} \quad (5)$$

where:

$t_i$  are the number of truck loads;

$d_i$  is the distance from manufacturer to site (km);

$fc_i$  is the fuel consumption (l/km);

$fCO_{2i}$  is the fuel combustion CO<sub>2</sub> emissions (kg<sub>CO<sub>2e</sub></sub>/l).

The third part looks at the carbon emitted during building erection (equation 6). The CO<sub>2</sub> emissions during construction and demolition of the building are obtained by summing over all materials the product of the equipment days on site, the fuel consumption per day and the fuel combustion CO<sub>2</sub> emissions per litre of fuel consumed.

$$EC_{\text{constr}} = \sum_{i=1}^n ed_i \times fc_i \times fCO_{2i} \quad (6)$$

where:

$ed_i$  are the equipment days on site;

$fc_i$  is the fuel consumption per day (l/day);

$fCO_{2i}$  are fuel combustion CO<sub>2</sub> emissions (kg<sub>CO<sub>2e</sub></sub>/l).

However, because we are comparing the structure only in this paper, we focused on the product life cycle stages (equation 4). Aiming at reducing the GHG emissions in the next decade to avoid extreme climate disruptions and focusing on structure, which generally does not require maintenance, this research prioritized the first life cycle stages in order to work with the two key variables SMQ and ECC.

## 5 RESULTS

### 5.1 Case Study 1: Pines Calyx

Helionix Designs is working on pilot projects that use rammed earth walls and tile vaulted roofs in order to create extremely low carbon buildings. One completed project is the Pines Calyx (Fig. 2) in St Margaret's Bay, Dover, United Kingdom.

The Pines Calyx is an event venue designed by Helionix Designs, in collaboration with Cameron Taylor and Conker Conservation, as an example of an extremely low-carbon building. The building illustrates how historical construction techniques can perform much better than contemporary buildings in terms of carbon emissions, energy needs and health. The client, The Bay Trust, and lead designer Alistair Gould of Helionix Designs wanted a carbon-neutral catalyst for rural and urban sustainable development. The design specified a lower carbon target than other sustainable projects had achieved, while still providing a high-quality, healthy environment. Rammed chalk walls, sourced from foundations excavations, and timber vaulted roofs largely replace traditional masonry and reinforced concrete.



Fig. 2: Pines Calyx.

### 5.2 Case Study 2: HiLo Nest building

The HiLo Nest project is a research and innovation centre planned as a penthouse guest apartment on the Empa Campus at ETH. The building will be illustrating lightweight concrete construction and adaptive building systems. The roof is an integrated thin shell and the floor system also uses thin vaulting.

The prefab integrated funicular vaulting system for the floors (Fig.3.a) is extremely lightweight, reducing the amount of concrete by 70%, when compared to traditional floor slabs.



Fig. 3: a) funicular floor systems b) HiLo Nest project [31].

### 5.3 Comparison of the results

To calculate the GWP of the entire building structure, two key variables are used: the SMQs in kg/m<sup>2</sup> and the cradle-to-site ECCs in kg<sub>CO<sub>2e</sub></sub>/kg. The cradle-to-site ECCs are obtained by summing cradle-to-gate ECCs and gate-to-site ECCs (the carbon emitted for the transport and the construction of 1 kg of material). Then the total cradle-to-site ECCs can be multiplied with the material quantities to obtain the GWP.

The interactive Database for Embodied Quantity Outputs (DEQO) was created for this research. Architects, engineers and researchers can input their project and compare its material quantities and embodied carbon with hundreds of other existing building structures, worldwide. This methodology was applied to existing building structures obtained throughout the industry. The two low carbon case studies in this paper are compared against the cradle-to-gate average from over 260 existing building structures currently in DEQO. More detailed explanations and results about these 260 buildings can be found in [32, 33].

The comparison of the results is shown in Fig. 4 and Fig. 5 (cradle-to-gate structure only). The Structural Material Quantities, normalized by the floor area (Fig. 4), demonstrate the material efficiency of the HiLo Nest building, due, mostly, to the innovative funicular floor system. Indeed, previous research demonstrated that the main contribution to the material quantities lies in the floor slabs.

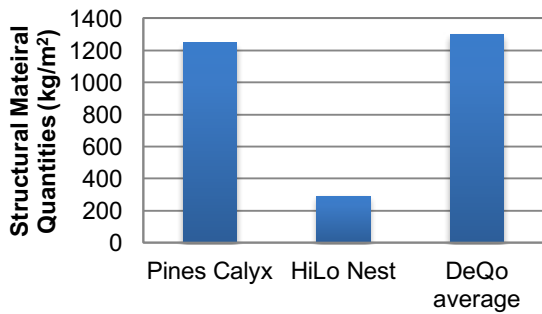

Fig. 4: Comparison of the material quantities.

However, when we translate this to the results for the GWP (Fig. 5), the influence of the material choices becomes clear. The Pines Calyx, using natural materials such as rammed chalk, has an environmental impact that is four times lower than the average building collected in the DeQo database.

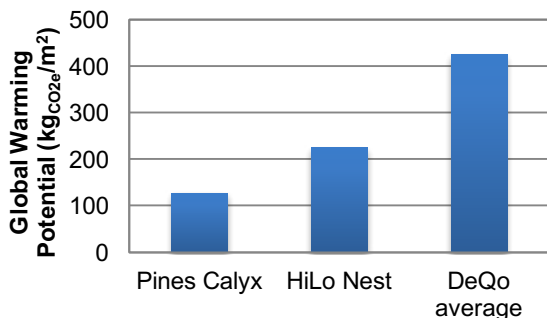

Fig. 5: Comparison of the embodied carbon.

## 6 DISCUSSION

These results demonstrate two main strategies to lower the embodied carbon of building structures:

- (i) Improve the material efficiency
- (ii) Choose low-carbon materials

The HiLo Nest Project focuses on reducing the material quantities with an innovative vaulted slab system, whereas the Pines Calyx restricts its environmental impact by using natural, local construction materials. The two strategies are not exclusive: low-carbon cement specification would further decrease the impact of the HiLo Nest system and the use of Timbrel vaults in the Pines Calyx minimised the use of concrete.

Note that the challenges in collecting accurate data for embodied carbon in building structures are twofold. Collecting the data on material volumes or mass requires a detailed Bill of Quantities from the contractor or an accurate Building Information Model from the designers. Estimating the most appropriate ECCs to calculate the GWP of the building structures relies on the material specifications as well as on the accessibility to databases such as ICE or EcolInvent and their accuracy.

## 7 CONCLUSIONS

In conclusion, we can now answer the two key questions:

- (i) The embodied carbon of current low carbon design ranges between 100 and 200 kg<sub>CO<sub>2</sub>e</sub>/m<sup>2</sup>.
- (ii) The case studies' embodied carbon is two to four times lower than typical buildings existing today.

The next steps are to gather more data-points and refine the accuracy of the data as well as to perform an uncertainty and sensitivity analysis. This research looks at carbon assessment as a part of standard LCA in order to define a baseline for benchmarks on the GWP of building structures. Upcoming steps are working with the Green Building Council and international standards to include these benchmarks in rating schemes and norms. Future research will expand to non-structural building products, in order to include the influence of maintenance and end-of-life impacts.

## 8 ACKNOWLEDGMENTS

The authors would like to thank Helionix Designs, the Block Research Group, the MIT presidential fellowship and the KuMIT project.

## 9 REFERENCES

- IPCC (2014), "Climate Change 2014: Mitigation of Climate Change." *International Panel for Climate Change (IPCC)*, Geneva, Accessed April 15, 2014. [www.ipcc.ch](http://www.ipcc.ch).
- Dixit M.K., Fernández-Solís J.L., Lavy S. and Culp C.H. (2012) "Need for an embodied energy measurement protocol for buildings: A review paper." *Renewable and Sustainable Energy Reviews*, 16 (6), pp. 3730-3743.
- USGBC (2013) "LEED v4 for Building Design And Construction." *U.S. Green Building Council or USGBC*, Washington D.C., 154p.
- BREEAM (2015). The world's leading design and assessment method for sustainable, buildings, last retrieved on July 9, 2015 at <http://www.breeam.org>
- Yang, F. (2014) "Benchmarking Embodied Impact Performance of Structure."

- Sustainable Structures Symposium*, Corey Griffin (ed.), Portland: Portland State University, April 17-18, pp. 131-146.
6. Webster, M. D., Meryman, H., Slivers, A., Rodriguez-Nikl, T., Lemay, L. & Simonen, K. (2012). *Structure and Carbon - How Materials Affect the Climate*. SEI Sustainability Committee, Carbon Working Group. Reston, VA: American Society of Civil Engineers (ASCE).
  7. Kaethner, S. and Burrige, J. (2012) "Embodied CO<sub>2</sub> of structural frames." *The Structural Engineer*, May, pp. 33-40.
  8. Simonen, K. (2011), *Motivating Low-Carbon Construction: Opportunities and Challenges A road map for rapid and significant impact*, Carbon Leadership Forum White Paper, University of Washington, College of Built Environments, Department of Architecture, Seattle, WA.
  9. Moncaster, A.M., & Symons, K.E. (2013) A method and tool for 'cradle to grave' embodied carbon and energy impacts of UK buildings in compliance with the new TC350, Cambridge: England, *Energy and Buildings* 66, pp. 514-523.
  10. Vares, S. & Häkkinen, T. (1998). *Environmental burdens of concrete and concrete products*. Espoo, Finland: Technical Research Centre of Finland, VTT Building Technology. Retrieved July 20, 2013, from <http://www.tekna.no/ikbViewer/Content/739021/doc-21-10.pdf>
  11. Lagerblad, B. (2005). *Carbon Dioxide Uptake During Concrete Life Cycle - State of the Art*. Stockholm, Sweden: Swedish Cement and Concrete Research Institute, CBI.
  12. Struble, L., & Godfrey, J. (1999). *How Sustainable is Concrete? International workshop on sustainable development and concrete technology*. Chicago, IL: University of Illinois.
  13. Young, S. B., Shannon T., Russell A. (2002). What LCA can tell us about the cement industry. *Five winds international; World business council for sustainable development*, Five Winds International, World Business Council for Sustainable Development, 117p.
  14. Chapman, P. F., & Roberts, F. (1983). *Metal Resources and Energy*. Butterworth-Heinemann Ltd.
  15. Institute of Stainless Steel Forum [ISSF]. (2004). *ISSF - Stainless steel LCI spreadsheet*. Brussels, Belgium: ISSF - institute of Stainless Steel Forum (ISSF). Retrieved September 12, 2013, from <http://www.worldstainless.org/Files/issf/non-image-files/PDF/GeneralIntroductiontostainlesssteelLCI1.pdf>
  16. International Iron and Steel Institute [IISI]. (2003). *The measure of our sustainability, Report of the world steel industry 2004*. International Iron and Steel Institute (IISI). Retrieved September 12, 2013, from [http://www.worldsteel.org/dms/internetDocumentList/bookshop/Sustainability\\_Report2004/document/2004%20Sustainability%20Report.pdf](http://www.worldsteel.org/dms/internetDocumentList/bookshop/Sustainability_Report2004/document/2004%20Sustainability%20Report.pdf)
  17. European Steel Industry and Climate Change. (2000). *EUROFER, European Confederation of Iron and Steel Industry*.
  18. Stubbles, J. (2007). *Carbon 'Footprints' in U.S. Steelmaking*. Steel Manufacturers Association SMA. Retrieved August 30, 2013, from <http://66.39.14.41/archive/20071120.htm>
  19. Pullen S. (2000b). Estimating the Embodied Energy of Timber Building Products, *Journal of the Institute of Wood Science*, 15 No. 3 (87), pp 147-151.
  20. Hammond, G. and Jones, C. (2010). "Inventory of Carbon & Energy (ICE), Version 1.6a." *Sustainable Energy Research Team (SERT), Department of Mechanical Engineering*, Bath: University of Bath.
  21. GaBi PE International. (2003) *GaBi 4 extension database III: steel module and GaBi 4 extension database XIV: construction materials module* Retrieved December 1, 2013, from [www.gabi-software.com](http://www.gabi-software.com)
  22. SimaPro. (2013) SimaPro UK Ltd. The world's most widely used LCA software. Retrieved November 12, 2013, from <http://www.simapro.co.uk>
  23. EcoInvent. (2013). Swiss Centre for Life Cycle Inventories, Retrieved December 13, 2012, from <http://www.ecoinvent.ch>
  24. OpenLCA (2015) Retrieved August 15, 2015, from <http://www.openlca.org>
  25. Athena Sustainable Materials Institute. (2009). *Impact Estimator for Buildings*. Retrieved November 15, 2013, from <http://www.athenasmi.org>
  26. Tally™ beta. (2013). *Revit add-in Tally™ (beta version). Real Time Environmental Impact tool. revised Tally™ Revit Application*, Kieran Timberlake Research Group, Retrieved December 2013, from <http://www.kierantimberlake.com/pages/view/95/tally/parent:4>
  27. SOM. (2013). *Environmental Analysis Tool™*. Skidmore, Owings & Merrill. Retrieved August 30, 2013, from <https://www.som.com/publication/environmental-analysis-tool-tm>
  28. WRAP. (2009). *Net Waste Tool*. Retrieved September 1, 2013, from <http://nwtool.wrap.prg.uk>
  29. Yang, F. (2013, July 11). ARUP. (C. De Wolf, Interviewer) San Francisco, CA, U.S.
  30. Vukotic, L., Fenner, R.A., Symons, K. (2010) "Assessing embodied energy of building structural elements." *ICE Engineering Sustainability*, September 2010, Issue ES3, 147-158, doi: 10.1680/ensu.2010.163.3.147
  31. Davis, L., Rippmann, M., Pawlofsky, T. and Block, P. (2012) Innovative funicular tile

vault: A prototype vault in Switzerland. *The Structural Engineer*. 90(11). p.46-56.

32. De Wolf, C., Ochsendorf, J., Cox, D., Hattan, A., Yang, F. and Charlson, A., "Material quantities and embodied carbon dioxide in structures", *ICE Journal of Engineering Sustainability*, 2015, DOI: 10.1680/ensu.15.00033.

33. De Wolf, C., and Ochsendorf, J., "Participating in an Embodied Carbon Database.", *The Structural Engineer*, February Issue, 2014, pp. 30-31.

# 06

## Site Visits

- NEST at Empa** 734
- A dynamic, modular research and demonstration platform for innovative building technologies
- Campus Tour – ETH Hoenggerberg** 736
- Three of ETH Zurich's most outstanding campus buildings with regards to construction methods, energy efficiency and building operation
- Development of the District 'Hardau'** 738
- Renewal of a derelict city district with public buildings, sport facilities, a housing development, a park area and art projects
- Cooperative 'mehr als wohnen'** 740
- A new neighbourhood initiated by Zurich cooperatives, aiming for housing affordability, social diversity and employment generation
- Swiss Society of Engineers and Architects (SIA)** 742
- An insight into SIA's area of activity and the Swiss public procurement sector



### NEST at Empa

June 16 / 15:30 – 18:30

NEST (Next Evolution in Sustainable Building Technologies) is a dynamic, modular research and demonstration platform for advanced and innovative building technologies on the Empa-Eawag campus in Dübendorf, Switzerland. The project provides a basic building infrastructure and access to an advanced geothermal system. The *backbone* of three open platforms can accept up to fifteen modular buildings – referred to as research and innovation units – thus offering a unique setting for academic groups and innovative companies to implement their research. These units are installed based on a plug-and-play principle by different consortiums of research and industry partners.

The NEST backbone was officially inaugurated in May 2016. It aims to accelerate the innovation process in the building and energy sector by enabling research, industry and the public sector to co-develop sustainable technologies, materials and systems and test them under real-world conditions. NEST offers residential and office space together with an experimental laboratory. Aside from new technologies, the residents and workers themselves are test subjects of the project. It can therefore be called a *living lab* in the truest sense of the word. And due to its modular character, NEST will remain open to future change

NEST can count on a network that meanwhile comprises around 90 partners from research, industry and the public sector such as Empa, Eawag, ETH Zurich, EPF Lausanne, the Canton of Zurich, the Swiss Federal Office of Energy, SwissLife, and Holcim. Numerous other partners are also involved in NEST and individual units. An overview is available online.

See [www.empa.ch/web/nest](http://www.empa.ch/web/nest)

SBE16 Zurich participants were offered an onsite tour guided by Reto Largo and Enrico Marchesi.



**above and right:**  
NEST\_exterior view and atrium  
both images © Roman Keller 2016.

### Campus Tour – ETH Hoenggerberg

June 16 / 15:30 – 18:00

June 17 / 16:30 – 19:00



Over the years, the Hoenggerberg campus at ETH Zurich has become the playground for ground breaking experiments in building technologies. This campus tour provided an insight into three of its most outstanding building projects with regards to construction methods, energy efficiency and building operation.

The tour started at the recently inaugurated House of Natural Resources (*HoNR*) – a 2D post-tensioned timber structure allowing earthquake resistance and extremely fast construction. Its facade features adaptive photovoltaic panels that showcase soft robotic technology developed at the Chair of Architecture and Building Systems. The campus tour also included a visit to the *Arch\_Tec\_Lab* – the new home of the Institute of Technology in Architecture that is currently in the final stages of onstruction. Here, a robotically assembled roof has

been designed by Gramazio Kohler Research Group. Finally, the refurbishment of the *HPZ building* was presented as an example of an innovative low exergy heating system. The retrofit approach as well as the ETH campus heating network were explained.

Guides: Arno Schlueter, Matthias Kohler, Chair of Andrea Frangi, Prageeth Jayathissa, Aleksandra Apolinarska



**opposite page:**

HoNR with Adaptive Solar Facade,  
© ETH Zurich, Chair of Architecture and  
Building Systems 2015.

**above:**

HoNR site visit, © ETH Zurich, Chair of  
Sustainable Construction 2016.

**center:**

Curved roof structure of Arch\_Tec\_Lab,  
© Andrea Diglas 2016.

**below:**

HPZ building – retrofit concept section,  
© ETH Zurich, Chair of Building Systems.

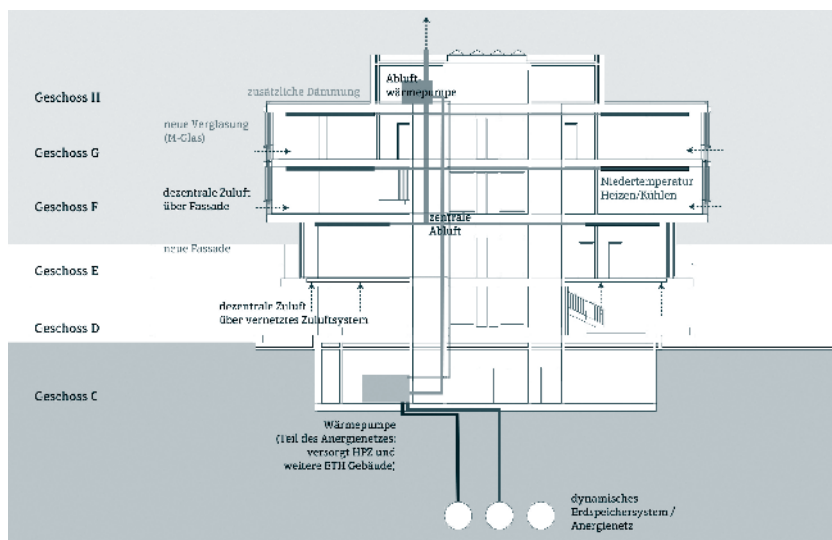

## Development of the District 'Hardau'

June 16 / 15:30 – 18:30

A city district of Zurich with former bad reputation has been enhanced with new public buildings, a housing development, a park area and art projects. This site visit featured, amongst others, new buildings with high requirements on sustainability and innovation: a secondary school, a school extension for apprentices, a sports center, a new multifunctional stadium and a residential building realised by a building cooperative.

Guides: Annette Aumann, Annick Lalive d'Epinay, Silvio Brunner

### 1 | Secondary school Albisrieden

More than just a school: urban design focal point, meeting point, public library. Concept: the school as an open-air facility.

### 2 | Residential building Badenerstrasse

A building complying with the 2000-Watt principles and the first 7-level timber construction in Zurich.

### 3 | <Public Space Art>

'Y' (why?) by the artist Sislej Xhafa.

### 4 | Power house Hardau II

Replaced the former oil/gas heating system with ground water heat pumps. Gas is still used for peak load coverage due to suboptimal building shells.

### 5 | School extension for apprentices

Designed as a Minergie-Standard building, result of an architecture competition.



### 6 | Primary school extension

Designed as a Minergie-Standard building, result of an architecture competition.

### 7 | <Architectural Art>

'Bell\*Hardau\*Bim\*Bam' by artists Claudia & Julia Müller.

### 8 | Sports Center Hardau

Result of an architecture competition. Designed as a 'floating space' on eight concrete columns.

### 9 | Hardau high-rises – upgrading measures

Following a social study of the area, different measures such as an integrated public kindergarden and refurbished entrance halls have been realised.

### 10 | Stadium Letzigrund

Designed as a multifunctional stadium. Due to the prior use of the site as a gravel pit, 40,000m<sup>3</sup> of excavated material could be used as 'Letzi gravel' onsite for the new concrete structure and 600,000 km of motorised transport could be avoided.

**opposite page:**  
Hardau high-rise buildings,  
© AHB Stadt Zürich.

**right:**  
Hardau high-rises - site plan  
with upgrading measures,  
© AHB Stadt Zürich.

**below:**  
Map of the guided tour through  
the Hardau district.

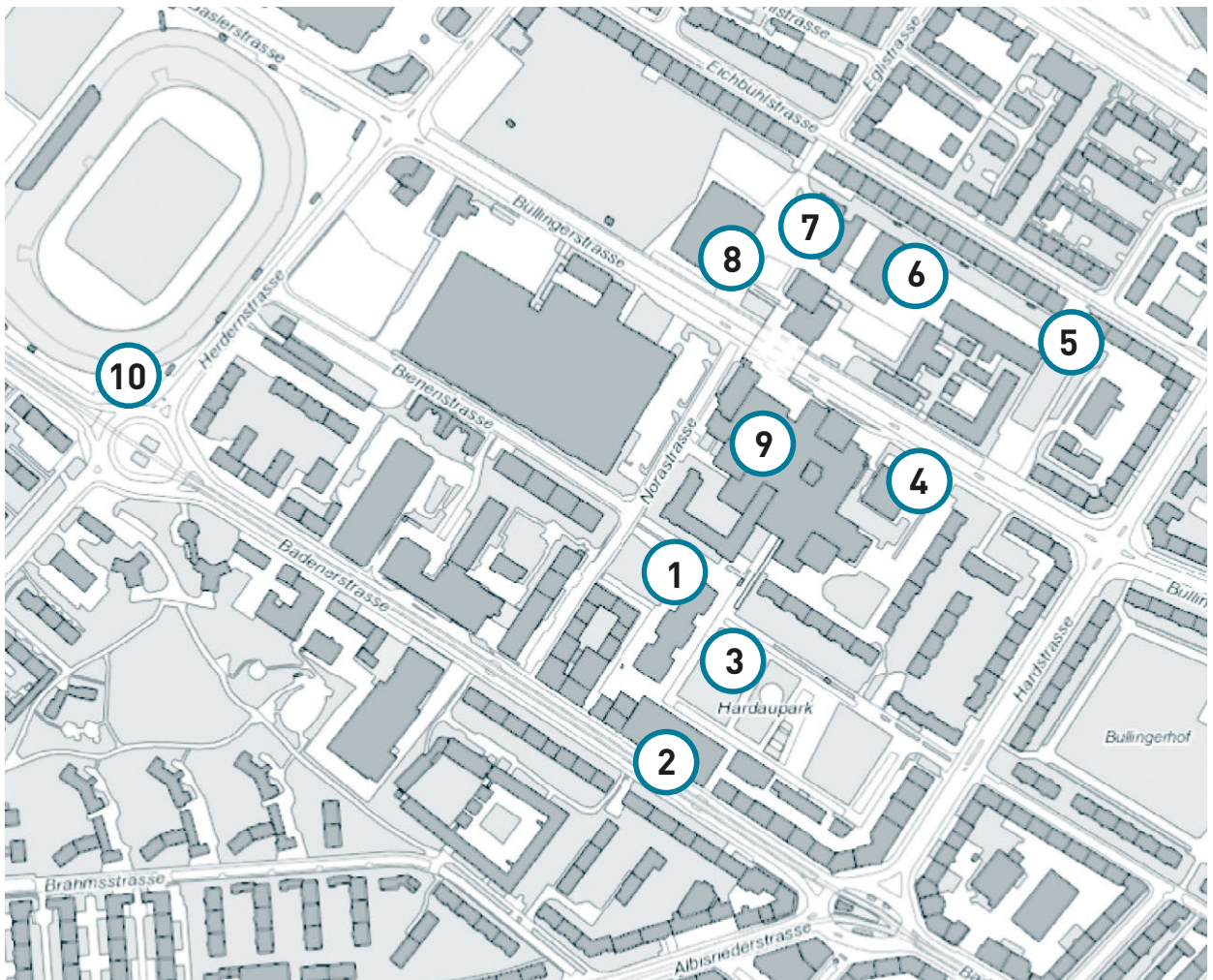
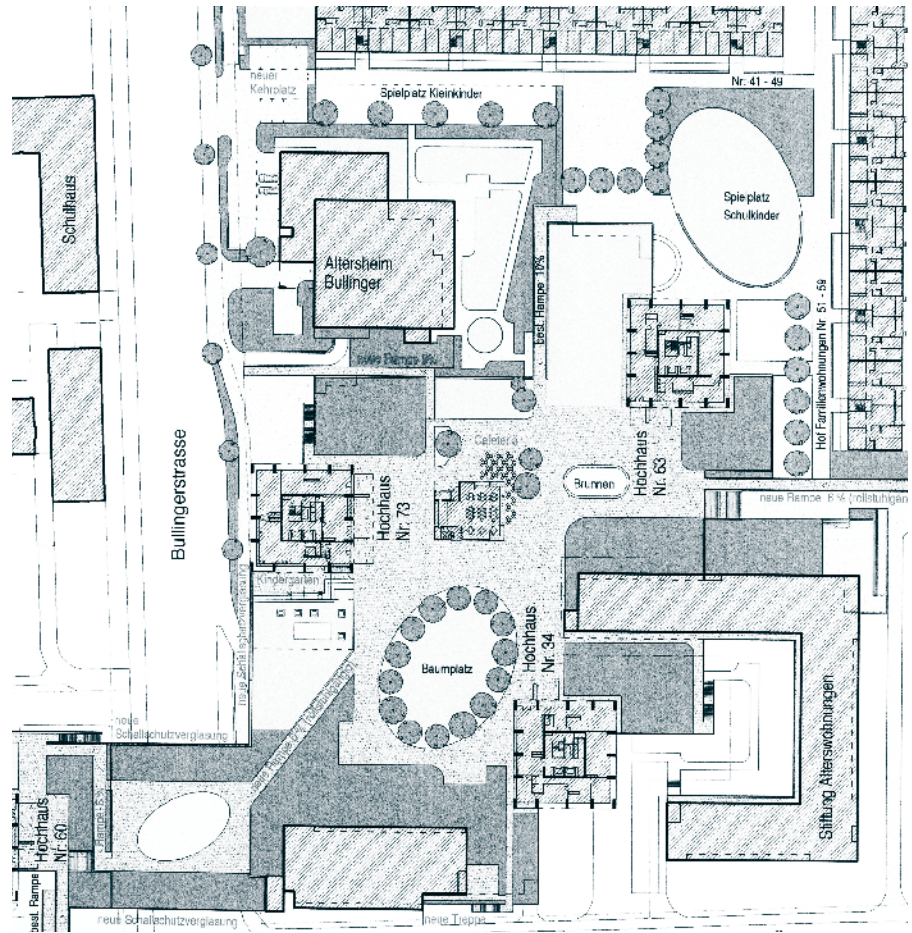



### Cooperative 'mehr als wohnen'

June 16 / 15:30 – 18:00

'mehr als wohnen' ('more than housing') is a Zurich neighbourhood - home to approximately 1,200 residents since 2015. It offers a broad variety of infrastructure, workshops and business spaces like a guesthouse, reception space, restaurants, kindergarten, music rehearsal studios and a bakery.

'mehr als wohnen' was initiated and founded by Zurich cooperatives. It is based on the ecological principles of the '2000Watt society' and aiming for housing affordability, social diversity and employment generation. Sustainable development is at the core of the project. The cooperative relies on the use of low energy technology, produces a significant share of its electrical energy with photovoltaics, and residents commit to renouncing the use of private cars, which is facilitated by car sharing and shared electric bikes.

Dialogue and participation were guiding principles during the planning process. Members of the founding cooperatives, neighbours, and future residents were invited to attend the sessions of the jury during the architectural competition and

to share information in regular plenary sessions in the progress of the project. In these discussions the future principles of cohabitation were established and different neighbourhood groups were founded.

The 13 different houses built by 5 architectural teams showcase the state of the art in sustainable building technologies. Different materials (e.g. wood, insulating concrete, monolithic brick walls), ventilation systems, and water recycling technologies have been implemented in the project.

'mehr als wohnen' has been widely published and discussed as a successful example of urban renewal and mixed-use development of a former industrial site. The project won the Special Prize of the Wienerberger Brick Award 2016, the European Community Led Housing Award and is nominated for the Zurich Architectural Prize.

See [mehralswohnen](#) online

Guide: Andreas Hofer





**opposite page:**  
Outdoor Areas Workshop with children,  
© Ursula Meisser.

Mobility Station with shared bicycle  
facilities, © Anna Haller.

**above:**  
Facades, © Ursula Meisser.

**right:**  
Atrium, © Ursula Meisser.



## Swiss Society of Engineers and Architects (SIA)

June 16 / 15:30 – 18:00

This tour started at the offices of the Swiss Society of Engineers and Architects (SIA). It provided insight into SIA's area of activity as well as the Swiss public procurement sector. During a guided walk with Andrea Leuenberger – project leader at the Zurich Civil Engineering Office, Department of Urban Space – participants gained insight into the complexity of urban projects with traffic considerations, urban design principles and social indicators.

Guides: Andrea Leuenberger, Denis Raschpichler, Susanne Kytzia

### 1 | Wiedikon station

traffic planning considerations such as through traffic and bypass, accompanying measures

### 2 | Intersection Birmensdorfer-/Weststrasse

planning history, western bypass, accompanying measures, ruling of the Swiss Federal Supreme Court

### 3 | Intersection West-/Zweierstrasse

requirements during the project, revitalisation Zweierstrasse, bike traffic, Zurich urban space strategy

### 4 | Brupbacherplatz

urban design approach, program, public square, gentrification, future development, public-benefit housing (25%)



### 5 | Seebahnstrasse

traffic planning considerations, design principles, multi-purpose zone/shared space planning

### 6 | Anny-Klawe-Platz

new square as recreational area, cooperative housing, design principles and expectations, participation

### 7 | Bullingerplatz

design principles, local square, meeting places, urban gardening, café

**opposite page:**

SIA office building in Zurich,  
© ETH Zurich, Chair of Sustainable  
Construction 2016.

**right:**

Workshop participants at SIA offices,  
© ETH Zurich, Chair of Sustainable  
Construction 2016.

**below:**

Map of the guided tour with Andrea  
Leuenberger.

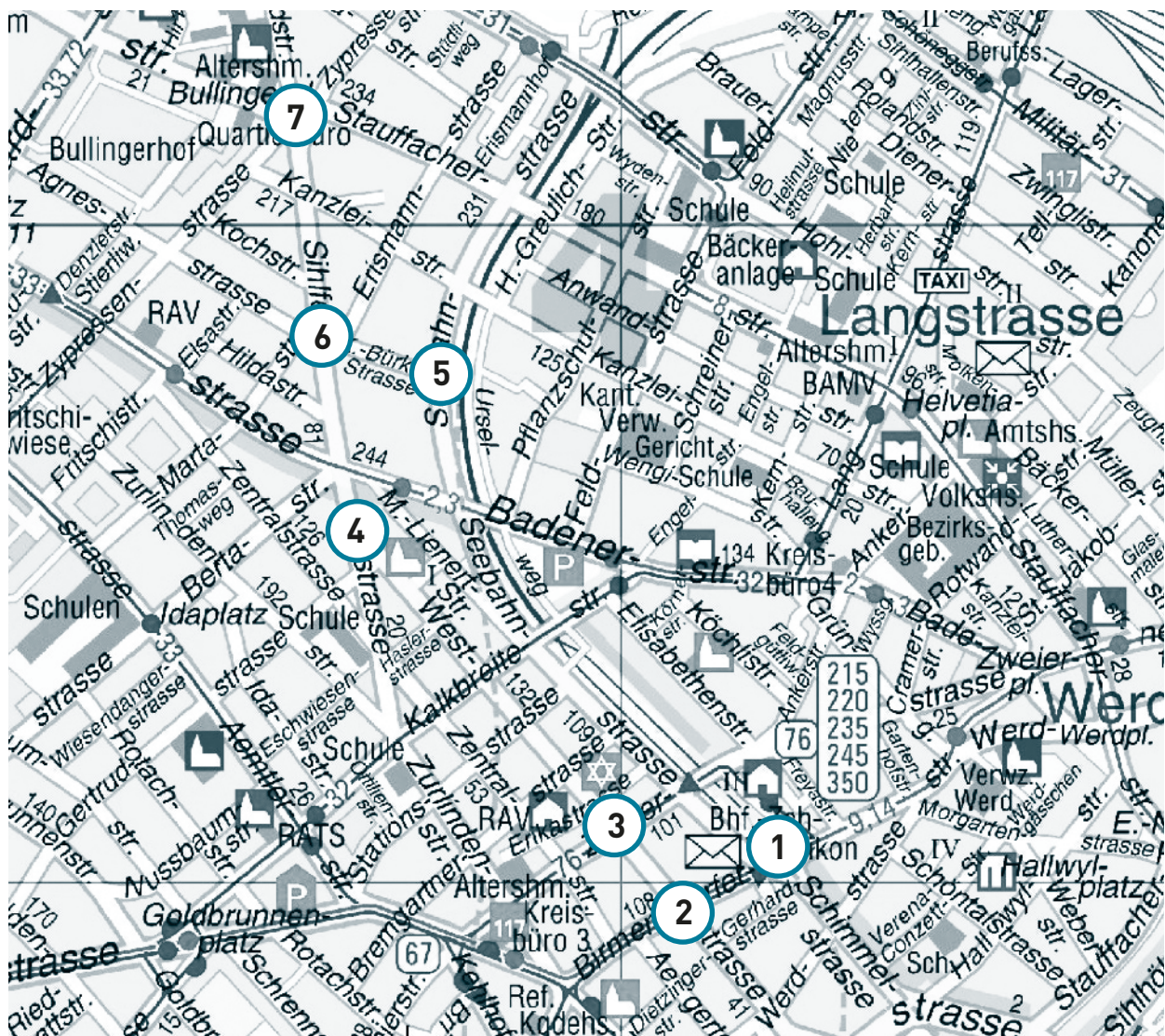



**List of Authors**

Abu-Eisheh, Sameer	148
Aguacil, Sergi	234
Allacker, Karen	328
Allacker, Karen	514
Arrigoni, Alessandro	436
Arrigoni, Alessandro	668
Assouline, Dan	130
Agusti-Juan, Isolda	304
Baldini, Luca	222
Barbano, Giulia	484
Brambilla, Arianna	136
Cajot, Sébastien	502
Cancio Diaz, Yudiesky	292
Cappai, Francesco	608
Cattarinussi, Laurent	656
Civiero, Paolo	460
Delem, Laetitia	364
De Wolf, Catherine	726
Druhmann, Carsten K.	580
Eisazadeh, Nazanin	688
Facchinetti, Emanuele	496
Falk, Paul Michael	108
Fantilli, Alessandro P.	414
Favier, Aurelie	644
Figueiredo, António José	196
Fonseca, Jimeno A.	96
Friedrich, Daniel	622
Gettu, Ravindra	430

Gomes, Vanessa	310
Greco, Angela	334
Greco, Angela	596
Gschösser, Florian	352
Gschösser, Florian	472
Gschösser, Florian	720
Guerra-Santin, Olivia	532
Guo, Hongshan	202
Hafner, Annette	442
Hammink, Coosje	208
Haufe, Nadine	184
Hollberg, Alexander	590
Houlihan Wiberg, Aoife Anne-marie	454
Hoxha, Endrit	154
Iannaccone, Giuliana	636
Ioannidou, Dimitra	568
Jaillon, Lara	426
John, Viola	378
John, Viola	478
Kamal, Azza	252
Kämpf, Jérôme	84
Kämpf, Jérôme	90
Katz, Amnon	404
Keyson, David	178
King, Marvin	628
Kleemann, Fritz	274
Klinge, Andrea	674
Krause, Karina	448
Kreiner, Helmuth	490
Landrou, Gnanli	662
Lasvaux, Sébastien	346
Lehmann, Meta	372
Leindecker, Herbert Claus	616
Maier, Stephan	46
Mailhac, Adélaïde	258
Mailhac, Adélaïde	266
Marinković, Snezana	390
Mastrucci, Alessio	280
Mavromatidis, Georgios	122
Meex, Elke	562
Mehrotra, Surabhi	78
Miyamoto, Ayu	556
Mokhtar, Ahmed	298

Motamed, Ali	216
Nagy, Zoltán	166
Nault, Emilie	574
Nippala, Eero	322
Oswald, Ferdinand	708
Ouellet-Plamondon, Claudiane	544
Pantelic, Jovan	316
Pasini, Daniel	520
Passer, Alexander	340
Pätzold, Matthias	650
Prieler, Manuela	538
Richner, Peter	160
Roswag-Klinge, Eike	674
Roux, Charlotte	550
Sanchez, Sofia	420
Saur, Alexandra	696
Schluck, Thomas	64
Schneider, Stefan	286
Silvestre, José	358
Steininger, Christian	240
Szkordilisz, Flora	102
Tagliabue, Lavinia Chiara	142
Tagliabue, Lavinia Chiara	172
Tagliabue, Lavinia Chiara	228
Tagliabue, Lavinia Chiara	602
Teitelbaum, Eric	114
Teitelbaum, Eric	714
Thomas, Daren	584
Trigaux, Damien	526
Van den Heede, Philip	408
Waibel, Christoph	70
Wastiels, Lisa	466
Willmann, Anja	52
Wu, Jiangbo	398
Wu, Raphael	58
Yang, Junjing	190
Yang, Junjing	246
Yazdanbakhsh, Ardavan	384
Zingg, Sharon	682
Zumstein, Ken	656
Zwicky, Daia	702

Download open access:  
ISBN: 978-3-7281-3774-6  
DOI: 10.3218/3774-6

[www.vdf.ethz.ch](http://www.vdf.ethz.ch)  
[verlag@vdf.ethz.ch](mailto:verlag@vdf.ethz.ch)



# Weitere aktuelle vdf-Publikationen finden Sie in unseren **Fachbereichsprospekten:**

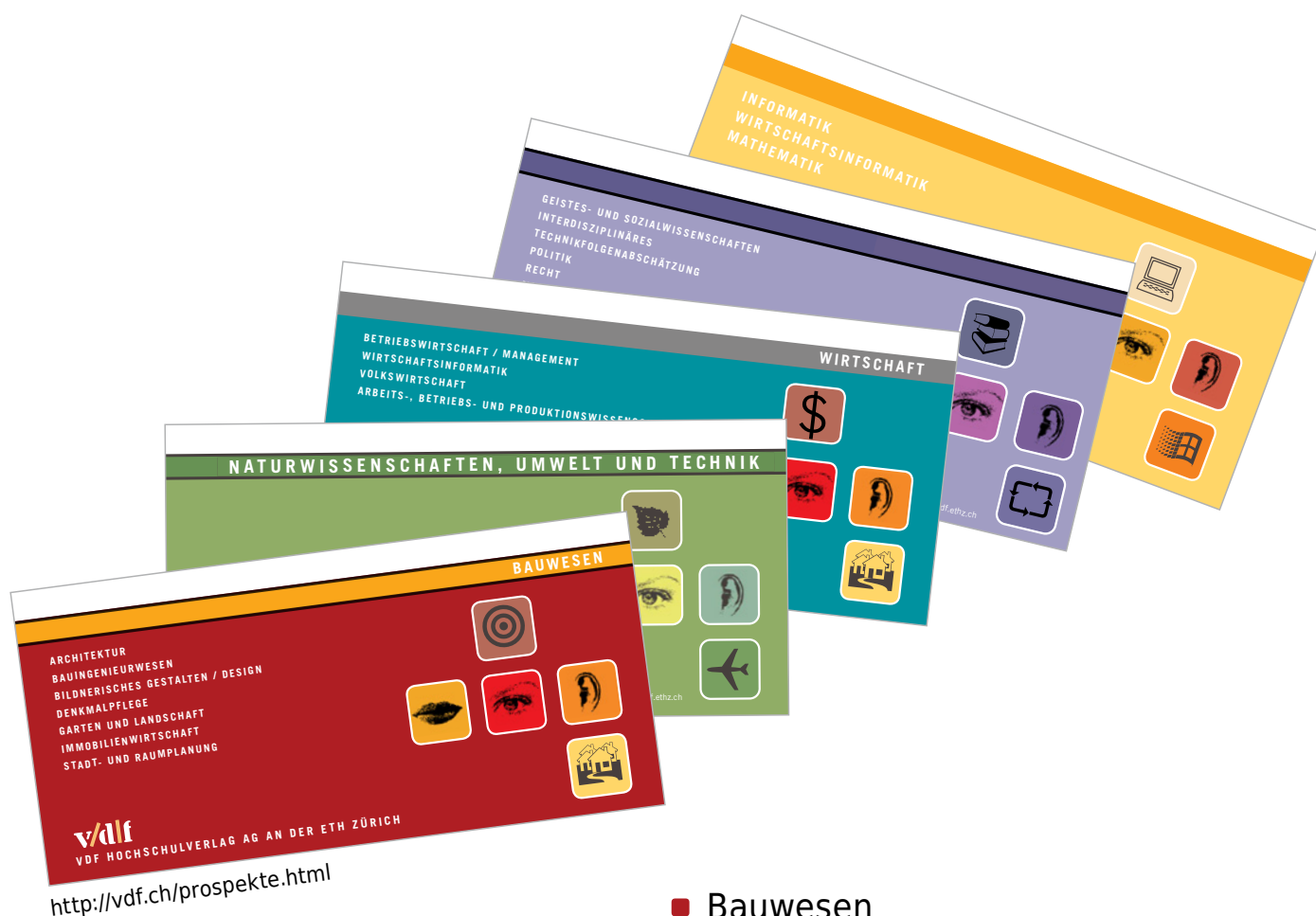

- Bauwesen
- Naturwissenschaften, Umwelt und Technik
- Wirtschaft
- Geistes- und Sozialwissenschaften, Interdisziplinäres, Militärwissenschaft, Politik, Recht
- Informatik, Wirtschaftsinformatik und Mathematik

Bücher als Websites und mehr...

**v/dlf**-online.ch

**v/dlf**

Hochschulverlag AG  
an der ETH Zürich



NEWSLETTER ABONNIEREN