

Factory of the future enabled by the virtual factory framework (VFF)

Conference Paper**Author(s):**

Bathelt, Jens; Politze, Daniel; Jufer, Noëlle; Jönsson, Anders; [Kunz, Andreas](#) 

Publication date:

2010

Permanent link:

<https://doi.org/10.3929/ethz-a-006050362>

Rights / license:

[In Copyright - Non-Commercial Use Permitted](#)

FACTORY OF THE FUTURE ENABLED BY THE VIRTUAL FACTORY FRAMEWORK (VFF)

Bathelt, J.; Politze, D. P.; Jufer, N.; Jönsson, A. & Kunz, A.

Abstract: Currently, the European project VFF composed by 30 project partners (SMEs, industry, and academia) has delivered its first results in order to support the transformation from the resource-intense production towards a sustainable, flexible, automated and knowledge-based production. This paper describes the underlying concepts of VFF and highlights the connection to Monitoring, Optimization and (Re-)Design as the essential activities in designing factories. In particular, the application of the introduced monitoring aspect will be outlined in relation to VFF.

Key words: Factory of the Future, Virtual Factory, Monitoring, Virtual Factory Framework

1. INTRODUCTION

1.1 Context

Manufacturing has to cope with a more and more complex and evolving market environment: on the one hand the crisis breaks the balance between demand and production; on the other hand the globalised market pushes for a continuous change. In this context, the ManuFuture technology platform has already proposed some activities to enable the transformation of European Manufacturing Industry into a knowledge-based sector capable of competing successfully in the globalised marketplace [2]. The ManuFuture vision identifies the following priorities to reach future competitiveness and sustainability: development of new high-added-value products and services, new business models, new manufacturing engineering,

emerging manufacturing science and technologies, as well as transforming R&D and educational infrastructures. Herein, the presentation of the new research project titled "Holistic, extensible, scalable and standard Virtual Factory Framework" - VFF (FP7-NMP-2008-3.4-1) highlights its answers to these challenges [1].

1.2 Paper structure

This paper is structured as follows: related work is addressed in the following section. This is followed by section 3 describing AMOR – an Agent for Assisting Monitoring, Optimization and (Re-)Design in factory design. In particular, the monitoring aspect of AMOR will be addressed in section 5 by applying these concepts within VFF. The principles of VFF itself are described in section 4.

2. RELATED WORK

2.1 Factory of the Future

The long-term shift from a cost-based competitive advantage to one based on high added value is envisioned by the „Factory of the Future“ [3]. Currently, the Private-Public Partnership (PPP) initiative regarding „Factories of the Future“ within the 7th Framework of the EU aims at helping European manufacturing enterprises, in particular SMEs, to adapt to global competitive pressures by developing the necessary enabling technologies to support EU manufacturing. The envisioned Factory of the Future meets the increasing global consumer demands for greener, more customized and higher quality products through the necessary transition to

a demand-driven industry with lower waste generation and energy consumption [3].

2.2 Related research projects

In the recent years, various research projects (e.g. “Modular Plant Architecture” - MPA, “A configurable virtual reality system for Multi-purpose Industrial Manufacturing Applications” – IRMA and “Digital Factory for Human-Oriented Production System” – DiFac [6]) studied the opportunity to apply new digital and virtual technologies in the manufacturing sector. The market proposes new software tools to assist the enterprises in facing new market needs (e.g. Siemens PLM solutions and Delmia), but usually only big companies can afford the large investments required by these tools [6]. Therefore, small and medium enterprises (SMEs) are still looking for successfully customised and less expensive solutions, which are more suitable for their size and needs [9]. The author’s point of view regarding factory design activities is summarized in the following section in order to be applied in section 5.

3. AMOR

According to [8], the following three essential activities in factory design are considered in AMOR - Agent for Assisting Monitoring, Optimization and (Re-)Design in factory design:

- Monitoring
- Optimization
- (Re-)Design

Monitoring operates on information that comes directly from either the Real or the Virtual Factory. This information is then transformed into a pre-defined measure that is more suitable for the evaluation, supervision and the assessment of data. Calculated values for Performance Indicators (PIs) are the output of Monitoring.

The Optimization activity’s input is the output of Monitoring. Optimization aims for smaller changes that lead to

improvements in terms of the performance indicators. In this way, Optimization may be interpreted as a transformation function that takes the information from the performance indicator values and creates evolutionary changes of the Virtual or Real Factory. Finally, (Re-)Design takes evolutionary changes and transforms them into a revolutionary change with a higher impact also on physical structures.

Three AMOR-activities can be embedded in a control loop as shown in Figure 1 [8].

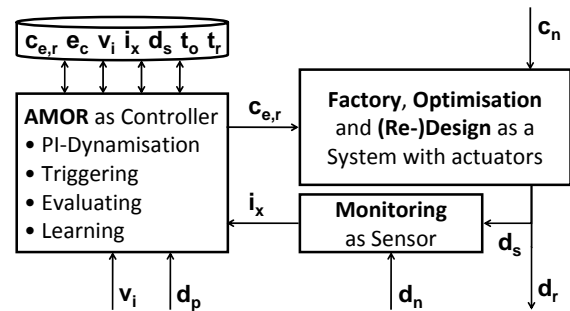

c_n	exogenous disturbances / changes
$c_{e,r}$	(r)evolutionary changes
d_r	real output data
i_x	performance indicator (for a goal x)
e_c	evaluation of the impact of a change
v_i	reference values for the PIs
d_s	sensored / measured data
d_p	prediction data
d_n	exogenous sensor input / data
t_o	trigger for performing an Optimization
t_r	trigger for performing a (Re-)Design

Fig. 1. AMOR control loop Assisting Monitoring, Optimization and (Re-)Design

As depicted, Optimization and (Re-)Design are seen as actuators that act on a Real or Virtual Factory and Monitoring is interpreted as a sensor that captures data from the factory to be controlled. The authors will focus on the monitoring aspect in the context of VFF.

4. VFF – VIRTUAL FACTORY FRAMEWORK

The Virtual Factory consists of an integrated simulation environment that considers the factory as a whole and provides an advanced planning, decision support and validation capability [11]. The VFF implements the framework for an object oriented collaborative virtualised environment, representing a variety of factory activities meant to facilitate the sharing of factory resources, manufacturing information and knowledge. VFF promotes major time and cost savings while improving collaborative design, management, (re)configuration and evaluation of new or existing facilities. This requires the capability to simulate dynamic complex behaviour over the entire life cycle of the factory that is considered as a complex and long living product [5]. The VFF approach identifies four key research pillars that must be addressed [4]:

- Pillar I; Development of a reference model for factory planning:
- A new planning framework, allowing parallel planning phases is part of the

reference model providing a consistent data platform, intelligent project management support systems and the visualization of cross-links and interconnections between planning objects through a virtual prototype. Existing product lifecycle management tools and methods are applied in the context of factory design inline with the paradigm „Factory as Product“. One outcome is the development of a factory data model for products, processes and resources.

- Pillar II; Development of the VF manager core:

The VF manager describes each element composing the manufacturing environment and their relations in order to perform a specific required activity. The VF manager guarantees data consistency and availability to any functional module.

Fig. 2. VFF lodestar [1]

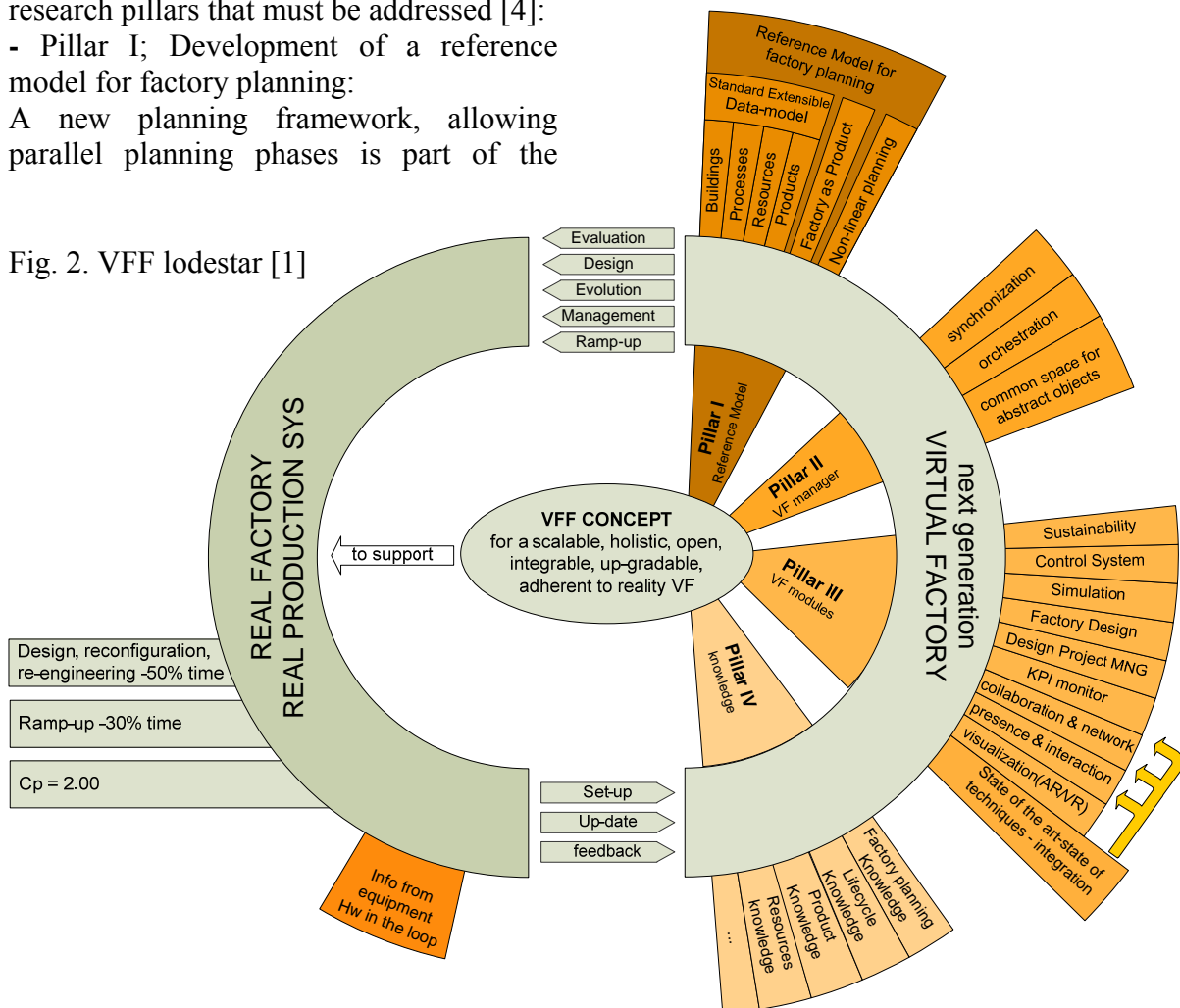

- Pillar III; Development of the decoupled functional modules:

The functional modules implement various tools and services for factory design, reconfiguration, evaluation and management, based on the requirements gathered among the thirty project partners by in-depth questionnaires. Expected results in the VFF project are collaborative customer-driven VF tools for cost-effective and rapid creation, management and use of complex knowledge-based factories.

- Pillar IV; Development of the knowledge repository and good practice:

The knowledge related to the manufacturing enterprise will be formalized by integrating strategies for adapting to fluctuating market demands, capacity planning methods, demand profiles and forecasts, modern business models and more.

The collaboration of the four pillars leads to the realization of the Virtual Factory concepts. The Virtual Factory itself, deployed according to the VFF concept, will be permanently synchronised with the Real Factory to achieve time and cost savings in the design, ramp-up, management, evaluation and reconfiguration of the real production itself. The Real Factory, interacting in terms of feedbacks and of data needed to set-up and up-date the simulation system, closes the loop.

The following three target values for the identified Key Performance Indicators (KPIs) are meant to establish quantifiable measures within VFF (Figure 2):

- Time for factory design, re-configuration, re-engineering: -50%:

The implementation of the new reference model for factory planning, integrated with formalized multi-competence knowledge deriving from past and current planning processes, allows shortening the time required for the design, re-configuration and re-engineering of new and existing processes, thanks to a quick retrieval of actual pertaining know-how, an intelligent selection of coherent functional modules.

- Ramp-up time -30%:

Quick, efficient and adherent to reality modelling speeds up analysis, synthesis and diagnosis, allowing an accurate but rapid prediction and optimization of production processes during the pre-production stage through preserving the reliability of information gathered during production ramp-up and its value-adding usability in the later stages.

- Process Capability Index $C_p \geq 2.0$:

The effective virtual representations of the entire production systems, fostering multi-loop evaluation procedures, multi-dimensional target systems, knowledge-driven decision support, quickened problem-solving sub-processes, allows a cost and time saving evaluation of existing and designed processes, resulting in radically enhanced production quality.

The need of verifying the impact of the VFF approach on the Real Factory asks for the cooperation of industrial partners to define demonstration scenarios that aim at testing and validating the proposed framework. Within the project, four demonstration scenarios (Figure 3) have been formulated by pairing different factory planning processes and industrial sectors.



Fig. 3. VFF scenarios [1]

1. The first scenario deals with the factory design and optimisation in the machining sector. The VFF tools will be used to (re)design the factory, aiming at higher solution efficiency and effectiveness, and

to optimise the configuration of the production systems. This scenario is developed with the cooperation of the industrial partners Compa S.A. and Ficep S.p.A.

2. The second scenario addresses the factory ramp-up and monitoring in the automotive and aerospace sectors. The VFF tools will enhance the capability to monitor the real factory and improve the set-up activities during the ramp-up phase. Volkswagen Autoeuropa and Alenia Aeronautica S.p.A. are the industrial partner involved in the second scenario.

3. The third scenario faces the factory reconfiguration and logistics in the automotive and white-goods sectors. The factory reconfiguration decisions can be supported by simulation and optimization tools, whereas logistics decisions need VFF tools to efficiently face variable demand by means of flexible networked operations. This scenario will be developed with the support of the industrial partners Audi Hungaria Motor and Frigoglass.

4. The final scenario aims at demonstrating the applicability of the VFF on the entire factory life-cycle. This integrated scenario focuses on the wood-working sectors thanks to the contribution of Homag AG.

5. FURTHER RESEARCH – MONITORING WITHIN VFF

VFF is in its initial stage and is developing a monitor for the scenario 2. Moreover, the project itself has to be monitored. Thus, all activities carried out within VFF should support the achievement of the envisioned strategic goals quantified by the three KPIs discussed in the last section. Two different monitoring activities are intended:

- Project Monitoring
- Monitoring of the Real Factory

5.1 VFF Project Monitoring

The four core work packages of VFF are directly connected to one of the four pillars (Figure 2). Thus, every (sub)-task within these work packages can be listed as a

perspective. The three KPIs shown in Figure 2 (Ramp-Up Time, Process Capability Index and Time for factory design, re-configuration, re-engineering) are listed accordingly in order to be further detailed [7]. This results in a matrix containing a network of Performance Indicators (PIs). E.g. pillar III is represented by work package 4 in VFF and task 4.2 is about selecting functional modules. Each functional module – like a “Factory design module” – has to contribute proportional to the overall goal specified by the KPIs. Each task in VFF which is directly related to research (RTD) can be assessed like this at every stage of the project.

5.2 Monitoring of the Real Factory

This monitoring activity is foreseen in scenario 2 within VFF. Crucial PIs are already collected and connected by establishing the PI network as it is used for the assessment of the project. In case of a Real Factory, other perspectives than the four pillars are relevant [7]. E.g. each of the activities “Production”, “Sales”... can be regarded as a perspective [10]. Thus, each of these perspectives allocates one row in the matrix as shown in Figure 4.

KPIs	Ramp-Up Time	Product Quality	...
Perspectives			
Production	Start of production - project start < 9 month	Process Capability Index (Cp) ≥ 2.0	
Sales	–	Customer satisfaction, J.D. Power Index > 80%	
...			

Fig. 4. AMOR-monitor

The network of PIs has now to be connected to the perspectives, whereas every cell contains in maximum one tuple-PI [7]:

- $PI(\text{Ramp-Up Time}|\text{Sales}) = \{\}$
- $PI(\text{Product Quality}|\text{Production}) = \text{Process Capability Index (Cp)} \geq 2.0$

By this, the KPIs are connected to the perspectives. Finally, this PI monitor can be customized according to the needs of

the various industry partners within VFF. The foreseen exploitation of the project results will also enable the implementation of this PI monitor at further companies.

6. CONCLUSION

This paper presents the initiated research project VFF describing its pillars, scenarios and KPIs. Moreover, the AMOR approach as a control loop in factory design is described. The corresponding “sensor” (monitoring) is applied in two ways: The *project monitoring* path can be regarded as an enabler for the envisioned PI based *factory monitor* within VFF.

ACKNOWLEDGEMENTS

The authors would like to thank the VFF team and the coordinator Marco Sacco for their support and contributions. Financial support from the European Commission via FP7 for the NMP project VFF is gratefully acknowledged.

REFERENCES

- [1] VFF, Holistic, extensible, scalable and standard Virtual Factory Framework, www.vff-project.eu/, (FP7-NMP-2008-3.4-1, 228595), 2009.
- [2] Manufuture, Manufuture Strategic Research Agenda, www.manufuture.org/documents/Manufuture%20SRA%20web%20version.pdf, Report of the High Level Group, Sept. 2006.
- [3] Jovane, F., Westkamper, E., Williams, D. *The ManuFuture Road: Towards Competitive and Sustainable High-Adding-Value Manufacturing*, Springer Berlin Heidelberg, 2009.
- [4] Pedrazzoli, P., Sacco, M., Jönsson, A., Boer, C.R. Virtual Factory Framework. Key enabler for future manufacturing, In *Digital Enterprise Technology* (P. F. Cunha, P. G. Maropoulos, eds.). Springer, US, 2007, 83-90.
- [5] Pedrazzoli, P., Rovere, D., Constantinescu, C., Bathelt, J., Pappas, M., Dépincé, P., Chryssolouris, G., Boër, C. R., Westkamper, E., High Value Adding VR Tools for Networked Customer-Driven Factory, *Proceedings of the 4th Int. Conf. on Digital Enterprise Technology - DET*, Bath, U.K., 2007, 347-352.
- [6] Sacco, M., Redaelli, C., Căndea, C., Georgescu, A. V., DiFac: an integrated scenario for the Digital Factory, *Proceedings of ICE*, June 2009.
- [7] Jufer, N., Politze, D. P., Bathelt, J. & Kunz, A., Performance Factory – A new approach of performance assessment for the Factory of the Future, *Proceedings of the 7th International Conference of DAAAM Baltic, INDUSTRIAL ENGINEERING*, Editor R.Kyttner, Tallinn, Estonia, April 2010.
- [8] Politze, D. P., Jufer N., Bathelt J., Kunz A., Wegener K., AMOR – An Agent for Assisting Monitoring, Optimization and (Re-)Design in Factory Design, *43rd CIRP International Conference of Manufacturing Systems*, Vienna, May 2010.
- [9] Consoni Florenzano Souza, M., Sacco, M., Vieira Porto, A.J. Virtual manufacturing as a way for the Factory of the Future, *Journal of Intelligent Manufacturing*, Springer, **6**, 725-735, 2006.
- [10] Jufer, N., Daaboul, J., Bathelt, J., Politze, D. P., Laroche, F., Bernard, A., Kunz, A., Performance Factory in the context of Mass Customization, *ICE 2010 - 16th Int. Conf. on Concurrent Enterprising*, Lugano, Switzerland, 2010.
- [11] Jain, S., Choong, NF., Aye, KM., Ming, L., Virtual Factory: an integrated approach to manufacturing system modelling, *Int. Journal of Operation and Production Management*, 2001, **21(5/6)**, 594-608.

CORRESPONDING ADDRESS

Dr. Jens Bathelt
IWF, ETH Zurich, ETH Zentrum
Tannenstr. 3, CLA G 19.2, CH-8092 Zurich
Phone: +41 44 632 35 15
E-mail: bathelt@iwf.mavt.ethz.ch
<http://www.iwf.mavt.ethz.ch>